

2SC5623

Silicon NPN Epitaxial High Frequency Low Noise Amplifier

HITACHI

ADE-208-977 (Z)

1st. Edition

Nov. 2000

Features

- High gain bandwidth product
 $f_T = 26$ GHz typ.
- High power gain and low noise figure ;
PG = 18 dB typ. , NF = 1.8 dB typ. at $f = 1.8$ GHz

Outline

CMPAK-4

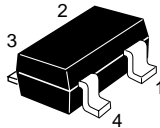

1. Emitter
2. Collector
3. Emitter
4. Base

Note: Marking is "WH-".

Absolute Maximum Ratings ($T_a = 25^\circ\text{C}$)

Item	Symbol	Ratings	Unit
Collector to base voltage	V_{CBO}	10	V
Collector to emitter voltage	V_{CEO}	3.5	V
Emitter to base voltage	V_{EBO}	1	V
Collector current	I_{C}	12	mA
Collector power dissipation	P_{c}	50	mW
Junction temperature	T_{j}	150	$^\circ\text{C}$
Storage temperature	T_{stg}	-55 to +150	$^\circ\text{C}$

Electrical Characteristics ($T_a = 25^\circ\text{C}$)

Item	Symbol	Min	Typ	Max	Unit	Test Conditions
Collector to base breakdown voltage	$V_{(\text{BR})\text{CBO}}$	10	—	—	V	$I_{\text{C}} = 10 \mu\text{A}$, $I_{\text{E}} = 0$
Collector cutoff current	I_{CBO}	—	—	1	μA	$V_{\text{CB}} = 8 \text{ V}$, $I_{\text{E}} = 0$
Collector cutoff current	I_{CEO}	—	—	1	μA	$V_{\text{CE}} = 3 \text{ V}$, $R_{\text{BE}} = \infty$
Emitter cutoff current	I_{EBO}	—	—	10	μA	$V_{\text{EB}} = 1 \text{ V}$, $I_{\text{C}} = 0$
DC current transfer ratio	h_{FE}	60	100	140	V	$V_{\text{CE}} = 2 \text{ V}$, $I_{\text{C}} = 10 \text{ mA}$
Collector output capacitance	C_{ob}	—	0.15	0.4	pF	$V_{\text{CB}} = 2 \text{ V}$, $I_{\text{E}} = 0$ $f = 1 \text{ MHz}$
Gain bandwidth product	f_{T}	23	26	—	GHz	$V_{\text{CE}} = 2 \text{ V}$, $I_{\text{C}} = 10 \text{ mA}$ $f = 2 \text{ GHz}$
Power gain	PG	14	18	—	dB	$V_{\text{CE}} = 2 \text{ V}$, $I_{\text{C}} = 10 \text{ mA}$ $f = 1.8 \text{ GHz}$
Noise figure	NF	—	1.8	2.3	dB	$V_{\text{CE}} = 2 \text{ V}$, $I_{\text{C}} = 3 \text{ mA}$ $f = 1.8 \text{ GHz}$

Main Characteristics

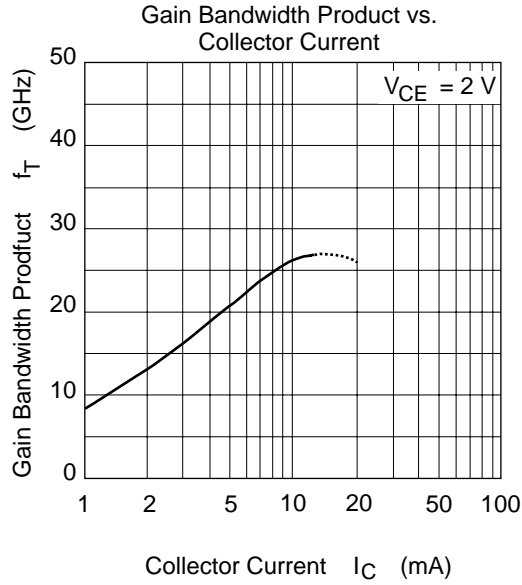
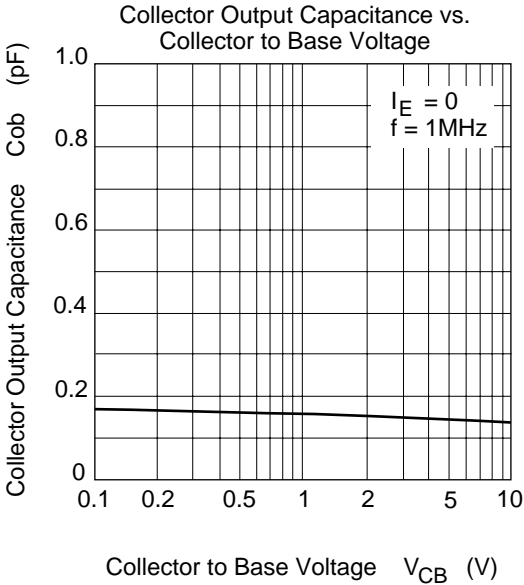
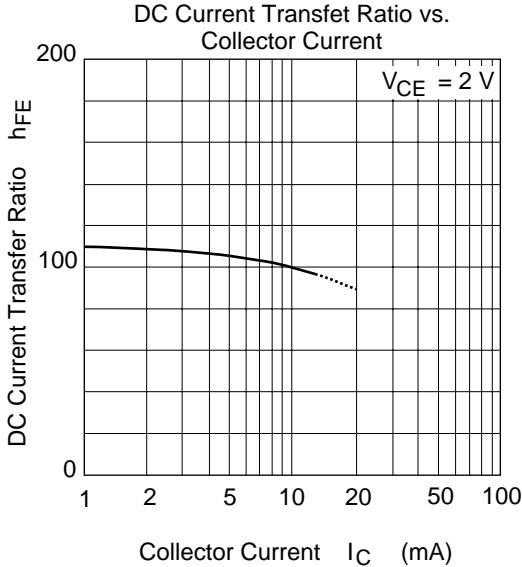
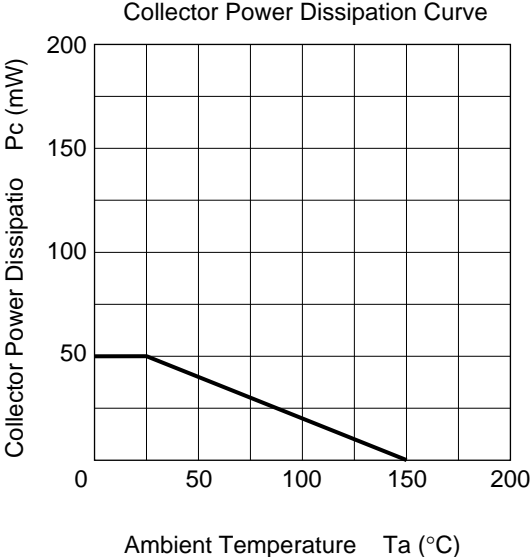

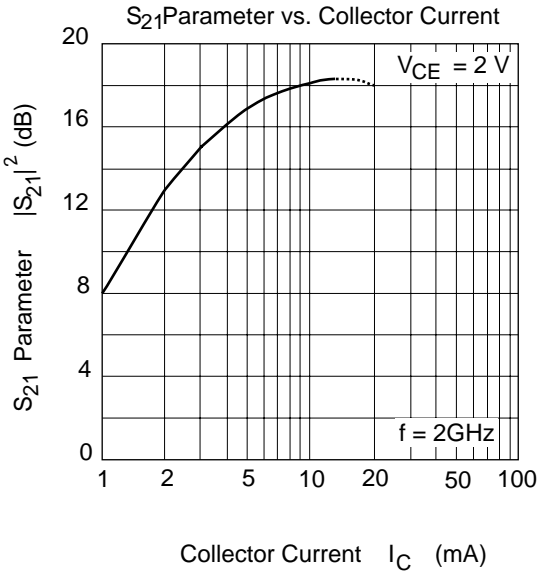
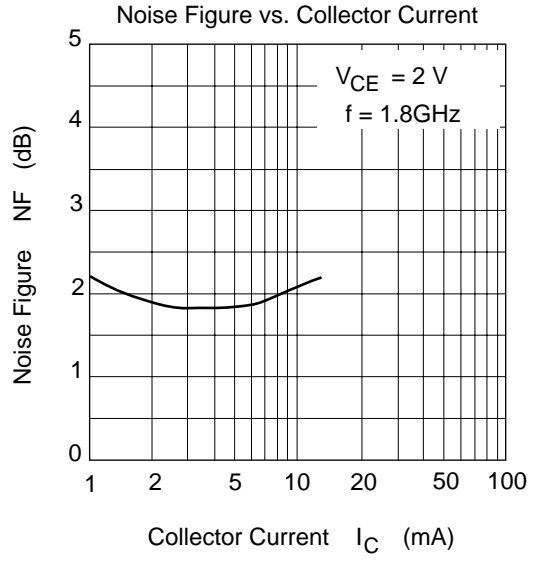
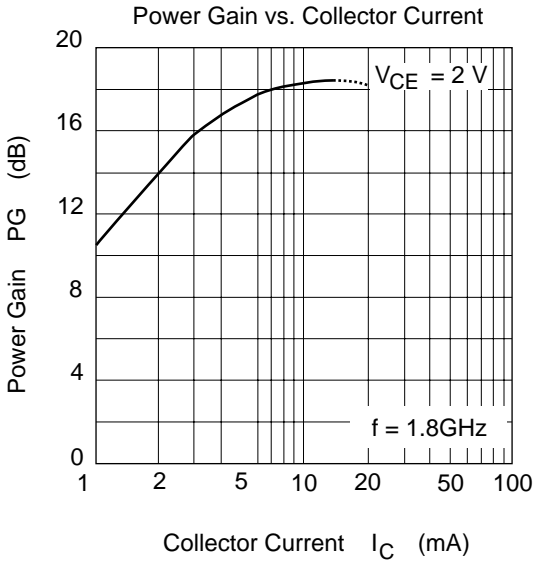

S11 Parameter vs. Frequency

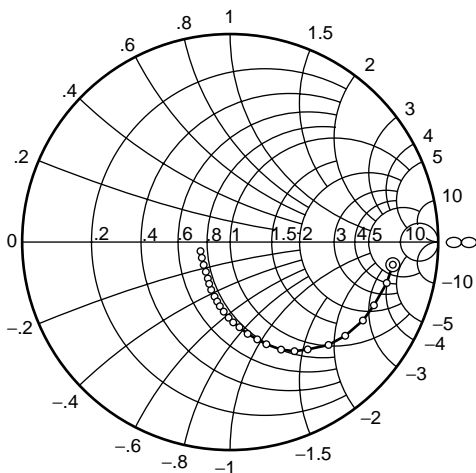

Condition : $V_{CE} = 2\text{ V}$, $I_C = 10\text{ mA}$

100 to 3000 MHz (100 MHz step)

⊙—○

S21 Parameter vs. Frequency

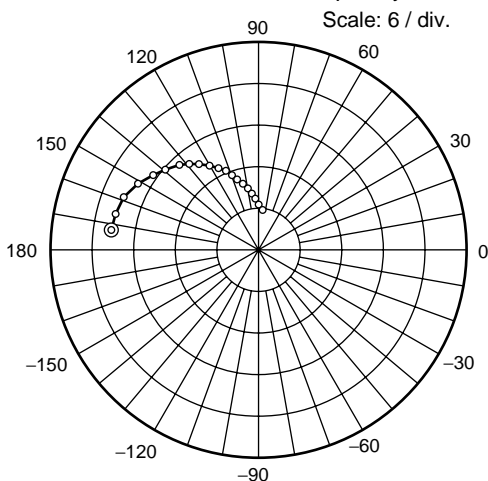

Condition : $V_{CE} = 2\text{ V}$, $I_C = 10\text{ mA}$

100 to 3000 MHz (100 MHz step)

⊙—○

S12 Parameter vs. Frequency

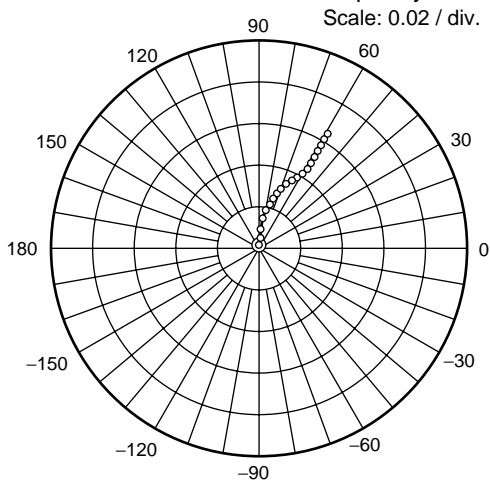

Condition : $V_{CE} = 2\text{ V}$, $I_C = 10\text{ mA}$

100 to 3000 MHz (100 MHz step)

⊙—○

S22 Parameter vs. Frequency

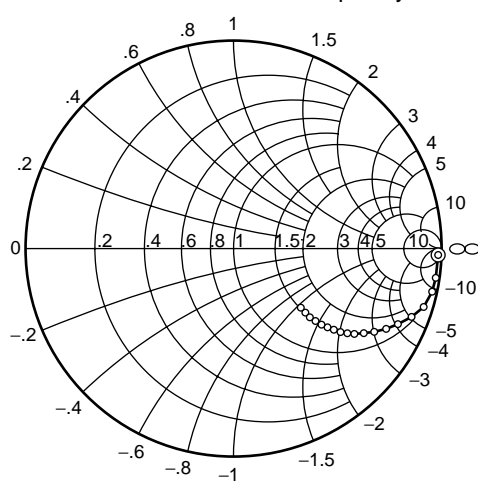

Condition : $V_{CE} = 2\text{ V}$, $I_C = 10\text{ mA}$

100 to 3000 MHz (100 MHz step)

⊙—○

Sparameter ($V_{CE} = 2\text{ V}$, $I_C = 10\text{ mA}$, $Z_o = 50\ \Omega$)

f (MHz)	S11		S21		S12		S22	
	MAG	ANG	MAG	ANG	MAG	ANG	MAG	ANG
100	0.779	-6.9	21.32	173.3	0.0028	95.3	0.971	-3.6
200	0.773	-14.5	20.95	166.2	0.0064	92.6	0.971	-7.5
300	0.763	-22.9	20.35	158.9	0.0102	91.8	0.961	-12.1
400	0.741	-31.4	19.65	151.7	0.0142	87.0	0.941	-16.7
500	0.714	-38.7	18.72	145.2	0.0183	83.4	0.911	-20.8
600	0.679	-46.2	17.65	139.3	0.0222	79.7	0.876	-24.7
700	0.641	-53.6	16.61	133.9	0.0255	75.6	0.836	-27.9
800	0.601	-59.7	15.54	129.3	0.0286	72.7	0.795	-30.8
900	0.563	-65.6	14.54	124.4	0.0313	69.5	0.756	-33.1
1000	0.523	-70.7	13.62	120.5	0.0335	67.8	0.720	-34.9
1100	0.488	-75.0	12.78	117.1	0.0356	66.0	0.687	-36.5
1200	0.458	-80.1	12.05	114.1	0.0376	64.1	0.657	-37.5
1300	0.427	-83.8	11.36	111.0	0.0393	62.8	0.628	-38.4
1400	0.400	-88.9	10.64	108.5	0.0410	62.4	0.607	-38.9
1500	0.374	-91.9	10.15	106.0	0.0426	61.0	0.582	-39.6
1600	0.350	-96.1	9.59	104.0	0.0441	61.1	0.567	-39.8
1700	0.326	-100.1	9.14	101.7	0.0455	60.4	0.548	-40.2
1800	0.304	-102.9	8.68	100.1	0.0469	59.7	0.533	-40.2
1900	0.282	-107.0	8.29	98.1	0.0486	59.1	0.521	-40.5
2000	0.267	-110.8	7.93	96.1	0.0500	59.2	0.508	-40.5
2100	0.253	-115.2	7.62	94.4	0.0517	59.3	0.498	-40.5
2200	0.234	-118.7	7.30	92.6	0.0527	59.2	0.489	-40.7
2300	0.225	-122.1	7.03	91.0	0.0543	58.6	0.481	-40.6
2400	0.212	-127.9	6.76	89.6	0.0557	58.4	0.473	-40.7
2500	0.199	-131.8	6.54	88.8	0.0573	58.2	0.468	-40.5
2600	0.193	-135.2	6.31	86.8	0.0579	58.3	0.461	-40.7
2700	0.186	-141.9	6.11	85.4	0.0600	58.2	0.456	-40.4
2800	0.178	-146.0	5.89	84.2	0.0612	58.2	0.450	-40.6
2900	0.177	-151.4	5.73	82.7	0.0624	58.3	0.447	-40.5
3000	0.168	-157.0	5.56	81.4	0.0642	57.8	0.442	-40.9

Package Dimensions

Unit: mm

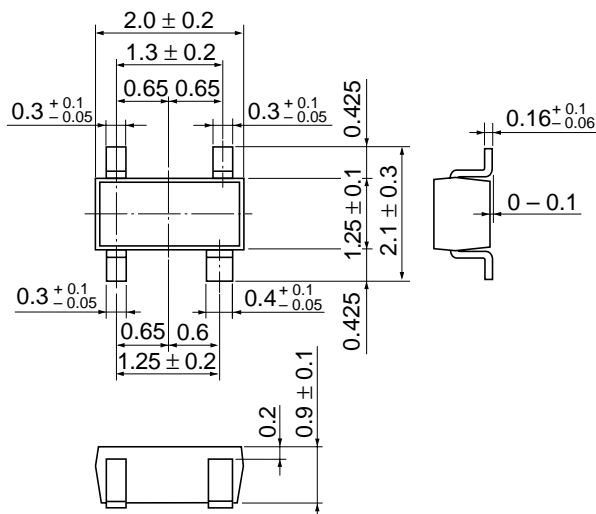

Hitachi Code	CMPAK-4(T)
JEDEC	—
EIAJ	Conforms
Mass (reference value)	0.006 g

Cautions

1. Hitachi neither warrants nor grants licenses of any rights of Hitachi's or any third party's patent, copyright, trademark, or other intellectual property rights for information contained in this document. Hitachi bears no responsibility for problems that may arise with third party's rights, including intellectual property rights, in connection with use of the information contained in this document.
2. Products and product specifications may be subject to change without notice. Confirm that you have received the latest product standards or specifications before final design, purchase or use.
3. Hitachi makes every attempt to ensure that its products are of high quality and reliability. However, contact Hitachi's sales office before using the product in an application that demands especially high quality and reliability or where its failure or malfunction may directly threaten human life or cause risk of bodily injury, such as aerospace, aeronautics, nuclear power, combustion control, transportation, traffic, safety equipment or medical equipment for life support.
4. Design your application so that the product is used within the ranges guaranteed by Hitachi particularly for maximum rating, operating supply voltage range, heat radiation characteristics, installation conditions and other characteristics. Hitachi bears no responsibility for failure or damage when used beyond the guaranteed ranges. Even within the guaranteed ranges, consider normally foreseeable failure rates or failure modes in semiconductor devices and employ systemic measures such as fail-safes, so that the equipment incorporating Hitachi product does not cause bodily injury, fire or other consequential damage due to operation of the Hitachi product.
5. This product is not designed to be radiation resistant.
6. No one is permitted to reproduce or duplicate, in any form, the whole or part of this document without written approval from Hitachi.
7. Contact Hitachi's sales office for any questions regarding this document or Hitachi semiconductor products.

HITACHI

Hitachi, Ltd.

Semiconductor & Integrated Circuits.
 Nippon Bldg., 2-6-2, Ohte-machi, Chiyoda-ku, Tokyo 100-0004, Japan
 Tel: Tokyo (03) 3270-2111 Fax: (03) 3270-5109

URL	North America	: http://semiconductor.hitachi.com/
	Europe	: http://www.hitachi-eu.com/hel/ecg
	Asia	: http://sicapac.hitachi-asia.com
	Japan	: http://www.hitachi.co.jp/Sicd/indx.htm

For further information write to:

Hitachi Semiconductor
 (America) Inc.
 179 East Tasman Drive,
 San Jose, CA 95134
 Tel: <1> (408) 433-1990
 Fax: <1> (408) 433-0223

Hitachi Europe GmbH
 Electronic Components Group
 Dornacher StraÙe 3
 D-85622 Feldkirchen, Munich
 Germany
 Tel: <49> (89) 9 9180-0
 Fax: <49> (89) 9 29 30 00

Hitachi Europe Ltd.
 Electronic Components Group.
 Whitebrook Park
 Lower Cookham Road
 Maidenhead
 Berkshire SL6 8YA, United Kingdom
 Tel: <44> (1628) 585000
 Fax: <44> (1628) 585160

Hitachi Asia Ltd.
 Hitachi Tower
 16 Collyer Quay #20-00,
 Singapore 049318
 Tel: <65>-538-6533/538-8577
 Fax : <65>-538-6933/538-3877
 URL : <http://www.hitachi.com.sg>

Hitachi Asia Ltd.
 (Taipei Branch Office)
 4/F, No. 167, Tun Hwa North Road,
 Hung-Kuo Building,
 Taipei (105), Taiwan
 Tel: <886>-(2)-2718-3666
 Fax : <886>-(2)-2718-8180
 Telex : 23222 HAS-TP
 URL : <http://www.hitachi.com.tw>

Hitachi Asia (Hong Kong) Ltd.
 Group III (Electronic Components)
 7/F., North Tower,
 World Finance Centre,
 Harbour City, Canton Road
 Tsim Sha Tsui, Kowloon,
 Hong Kong
 Tel : <852>-(2)-735-9218
 Fax : <852>-(2)-730-0281
 URL : <http://www.hitachi.com.hk>

Copyright © Hitachi, Ltd., 2000. All rights reserved. Printed in Japan.
 Colophon 2.0