

No.1241

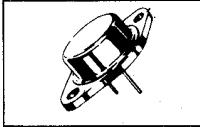

2SD1340P

NPN Triple Diffused Planar Type Silicon Transistor
For Horizontal Output (Built-in Damper Diode)

Features:

- High Breakdown Voltage and High Reliability.
- High Switching Speed.

Absolute Maximum Ratings at Ta=25°C

| | | | unit |
|---------------------------|------------------|-------------|------|
| Collector to Base Voltage | V _{CB0} | 1500 | V |
| Collector to Base Voltage | V _{CEO} | 800 | V |
| Emitter to Base Voltage | V _{EB0} | 7 | V |
| Collector Current | I _C | 3.5 | A |
| Peak Collector Current | i _{cp} | 10 | A |
| Collector Dissipation | P _C | 50 | W |
| Junction Temperature | T _j | 150 | °C |
| Storage Temperature | T _{stg} | -55 to +150 | °C |

Electrical Characteristics at Ta=25°C

| | | | min | typ | max | unit |
|--------------------------|----------------------|---|------|-----|-----|------|
| Collector Cutoff Current | I _{CBO} | V _{CB} =800V, I _E =0 | | | 10 | uA |
| Emitter Cutoff Current | I _{EBO} | V _{EB} =4V, I _C =0 | 40 | | 130 | mA |
| DC Current Gain | h _{FE} | V _{CE} =5V, I _C =0.5A | 8 | | | |
| Gain Bandwidth Product | f _T | V _{CE} =10V, I _C =0.5A | | 3 | | MHz |
| C-E Saturation Voltage | V _{CE(sat)} | I _C =2.5A, I _B =0.8A | | | 8 | V |
| B-E Saturation Voltage | V _{BE(sat)} | I _C =2.5A, I _B =0.8A | | | 1.5 | V |
| C-B Breakdown Voltage | V(BR)CBO | I _C =5mA, I _E =0 | 1500 | | | V |
| C-E Breakdown Voltage | V(BR)CEO | I _C =100mA, R _{BE} =∞ | 800 | | | V |
| E-B Breakdown Voltage | V(BR)EBO | I _E =200mA, I _C =0 | 7 | | | V |
| Diode Forward Voltage | V _F | I _{EC} =3.5A | | | 2 | V |
| Fall Time | t _f | I _C =3A, I _{B1} =0.8A, I _{B2} =-1.6A V _{CC} =200V, R _L =66.7ohm | | | 0.7 | us |

Switching Time Test Circuit

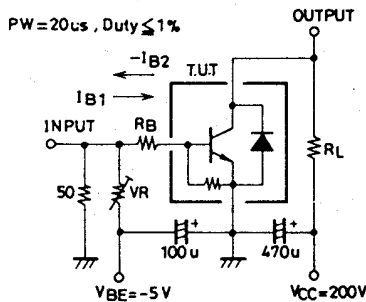

**Case Outline 2017
(unit:mm)**

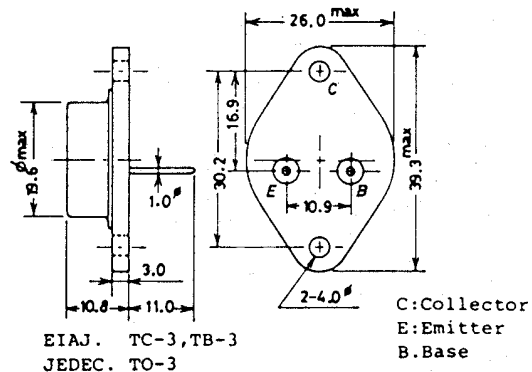

These specifications are subject to change without notice.