

2SD1418

SILICON NPN EPITAXIAL

LOW FREQUENCY POWER AMPLIFIER

Complementary pair with 2SB1025

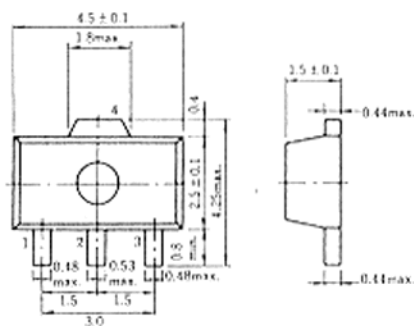

(UPAK)

1. Base
 2. Collector
 3. Emitter
 4. Collector
- (Dimensions in mm)

■ ABSOLUTE MAXIMUM RATINGS (Ta=25°C)

Item	Symbol	2SD1418	Unit
Collector to base voltage	V_{CBO}	120	V
Collector to emitter voltage	V_{CEO}	80	V
Emitter to base voltage	V_{EBO}	5	V
Collector current	I_C	1	A
Collector peak current	$i_{C(peak)}$ *	2	A
Collector power dissipation	P_C^{**}	1	W
Junction temperature	T_j	150	°C
Storage temperature	T_{stg}	-55 to +150	°C

* PWS10ms, Duty cycle ≤20%.

** Value on the alumina ceramic board (12.5×20×0.7mm)

MAXIMUM COLLECTOR DISSIPATION CURVE

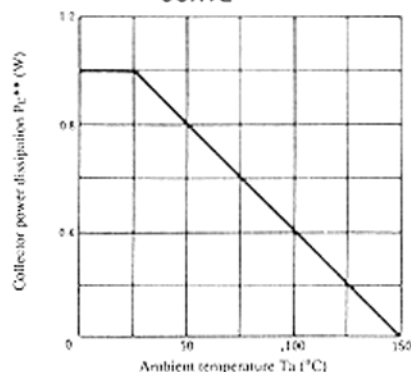

■ ELECTRICAL CHARACTERISTICS (Ta=25°C)

Item	Symbol	Test Condition	min.	typ.	max.	Unit
Collector to base breakdown voltage	$V_{(BR)CBO}$	$I_C = 10\mu A, I_E = 0$	120	—	—	V
Collector to emitter breakdown voltage	$V_{(BR)CEO}$	$I_C = 1mA, R_{BE} = \infty$	80	—	—	V
Emitter to base breakdown voltage	$V_{(BR)EBO}$	$I_E = 10\mu A, I_C = 0$	5	—	—	V
Collector cutoff current	I_{CBO}	$V_{CB} = 100V, I_E = 0$	—	—	10	μA
DC current transfer ratio	h_{FE1} *	$V_{EB} = 5V, I_C = 150mA^{**}$	60	—	320	
	h_{FE2}	$V_{CE} = 5V, I_C = 500mA^{**}$	30	—	—	
Collector to emitter saturation voltage	$V_{CE(sat)}$	$I_C = 500mA, I_B = 50mA^{**}$	—	—	1	V
Base to emitter voltage	V_{BE}	$V_{CE} = 5V, I_E = 150mA^{**}$	—	—	1.5	V
Gain bandwidth product	f_T	$V_{CE} = 5V, I_C = 150mA^{**}$	—	140	—	MHz
Collector output capacitance	C_{ob}	$V_{CB} = 10V, I_E = 0, f = 1MHz$	—	12	—	pF

* The 2SD1418 is grouped by h_{FE1} as follows.

** Pulse Test

Mark	DA	DB	DC
h_{FE1}	60 to 110	100 to 200	160 to 320

2SD1418

TYPICAL OUTPUT CHARACTERISTICS

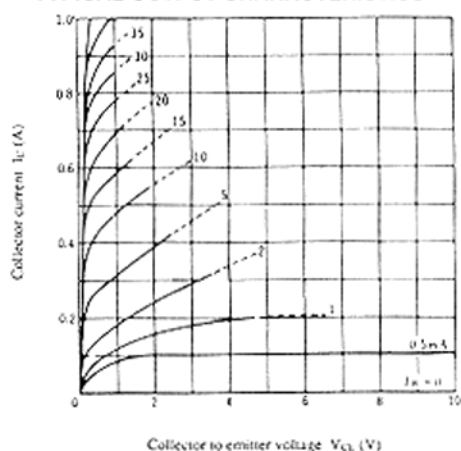

TYPICAL TRANSFER CHARACTERISTICS

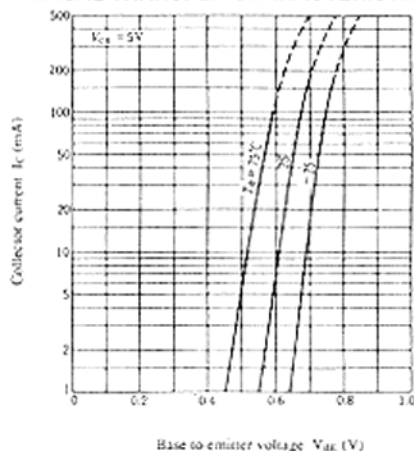

DC CURRENT TRANSFER RATIO VS. COLLECTOR CURRENT

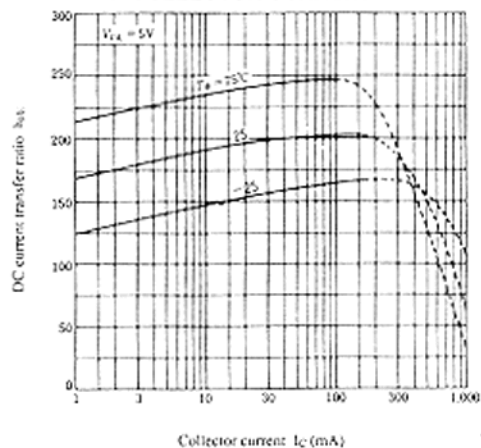

SATURATION VOLTAGE VS. COLLECTOR CURRENT

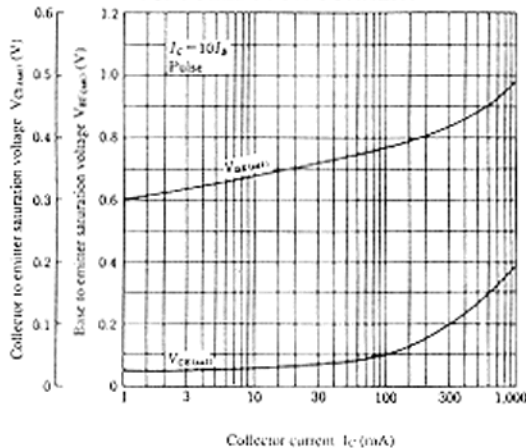

GAIN BANDWIDTH PRODUCT VS. COLLECTOR CURRENT

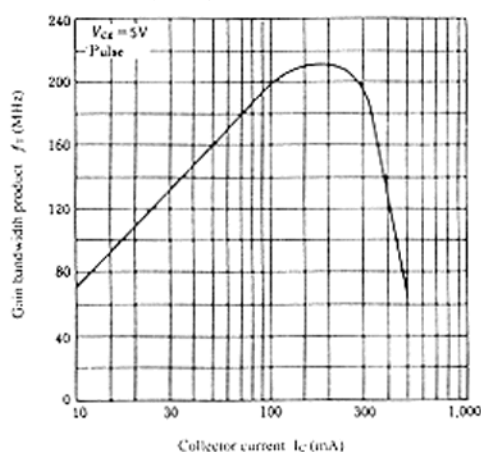

COLLECTOR OUTPUT CAPACITANCE VS. COLLECTOR TO BASE VOLTAGE

