

2SD1976

Silicon NPN Triple Diffused
High Voltage Switching, Igniter

Feature

- Built-in High voltage zener diode (300 V)
- High Speed switching

Absolute Maximum Ratings (Ta = 25°C)

Item	Symbol	Rating	Unit
Collector to base voltage	V_{CBO}	300	V
Collector to emitter voltage	V_{CEO}	300	V
Emitter to base voltage	V_{EBO}	7	V
Collector current	I_C	6	A
Diode Current	I_D^{*1}	6	A
Collector peak current	$i_{C(peak)}$	10	A
Collector power dissipation	P_C^{*1}	40	W
Junction temperature	T_j	150	°C
Storage temperature	T_{stg}	-55 to +150	°C

Note: 1. Value at $T_C = 25^\circ\text{C}$.

Electrical Characteristics (Ta = 25°C)

Item	Symbol	Min	Typ	Max	Unit	Test condition
Collector to base breakdown voltage	$V_{(BR)CBO}$	300	—	420	V	$I_C = 0.1 \text{ mA}, I_E = 0$
Collector to emitter sustain voltage	$V_{CEO(SUS)}$	300	—	—	V	$I_C = 3 \text{ A}, R_{BE} = \infty, L = 10 \text{ mH}$
Emitter to base breakdown voltage	$V_{(BR)EBO}$	7	—	—	V	$I_E = 50 \text{ mA}, I_C = 0$
Collector cutoff current	I_{CEO}	—	—	100	μA	$V_{CE} = 300 \text{ V}, R_{BE} = \infty$
DC current transfer ratio	h_{FE}	500	—	—		$V_{CE} = 2 \text{ V}, I_C = 4 \text{ A}$
Collector to emitter saturation voltage	$V_{CE(sat)}$	—	—	1.5	V	$I_C = 4 \text{ A}, I_B = 40 \text{ mA}$
Base to emitter saturation voltage	$V_{BE(sat)}$	—	—	2.0	V	$I_C = 4 \text{ A}, I_B = 40 \text{ mA}$
Emitter to Collector diode forward voltage	V_{ECF}	—	—	3.5	V	$I_F = 6 \text{ A}$

TO-220AB

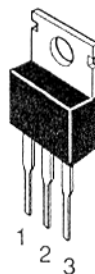

1. Base
2. Collector (Flange)
3. Emitter

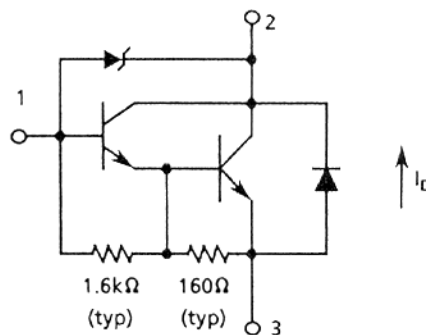

2SD1976

Electrical Characteristics (Ta = 25°C) (cont)

Item	Symbol	Min	Typ	Max	Unit	Test condition
Turn on time	t_{on}	—	1.2	—	μs	$I_C = 4 A, V_{CC} = 20 V$ $I_{B1} = -I_{B2} = 40 mA$
Storage time	t_{stg}	—	8.0	—		
Fall time	t_f	—	8.0	—		

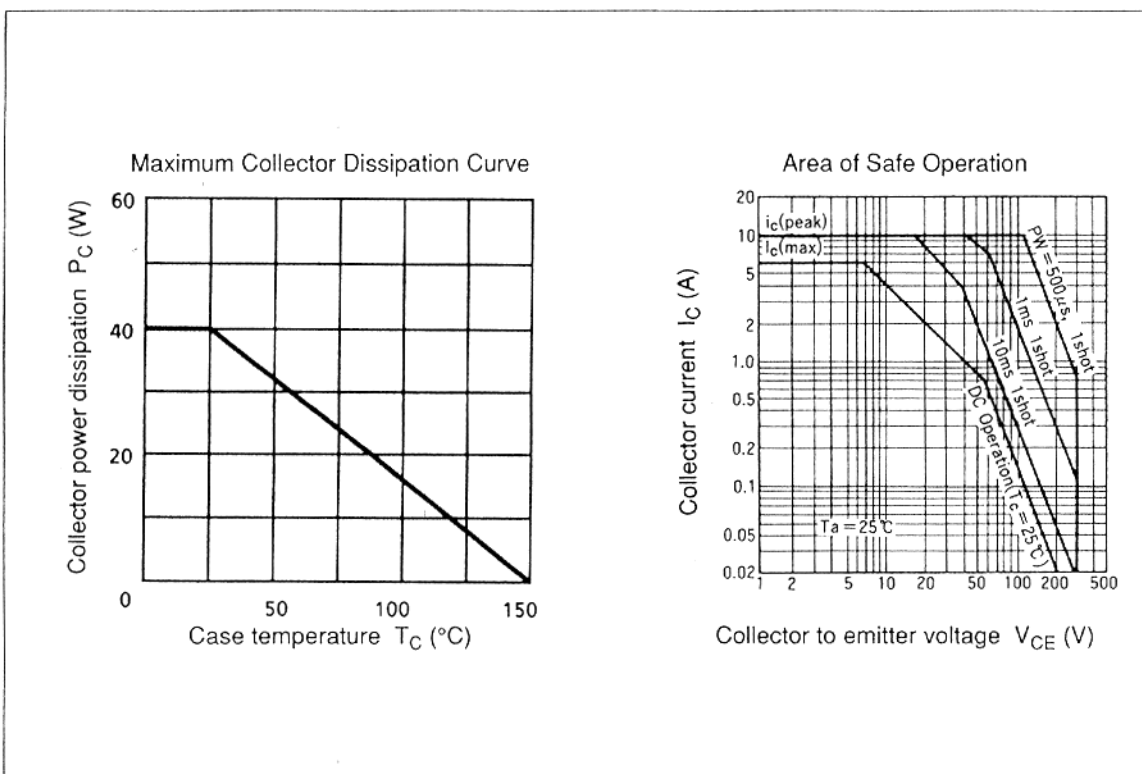

Typical Output Characteristics

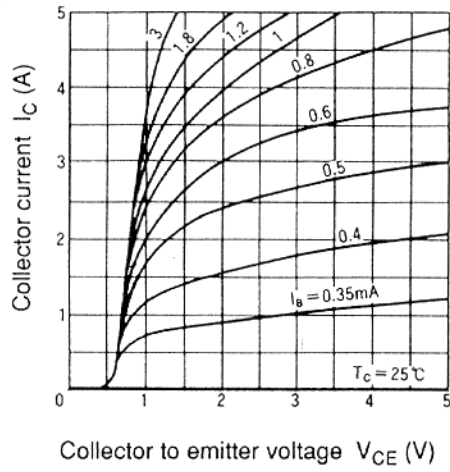

DC Current Transfer Ratio vs. Collector Current

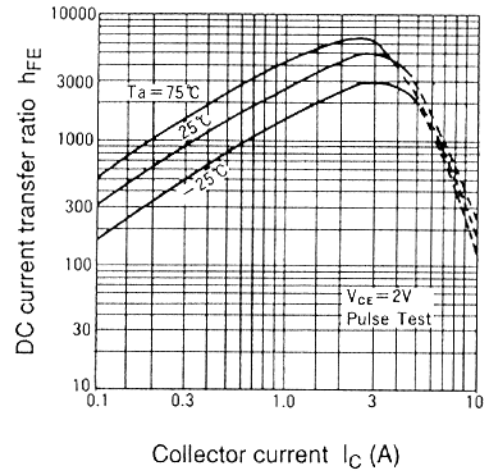

Saturation Voltage vs. Collector Current

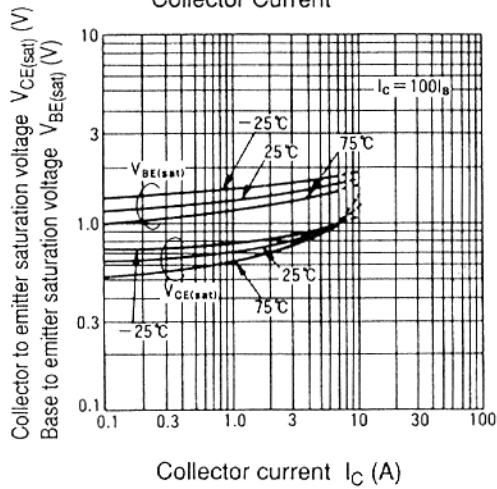

Transient Thermal Resistance

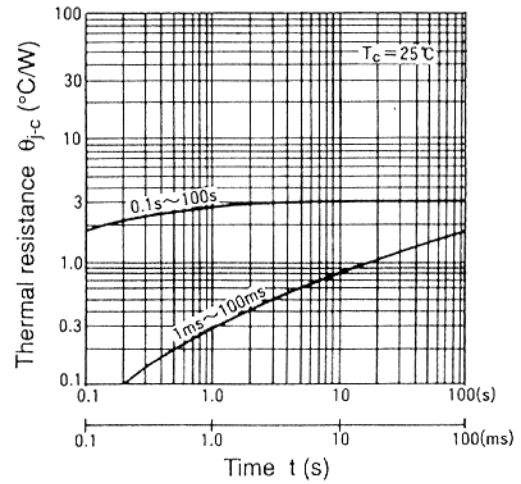

2SD1976

