

2SD2105

Silicon NPN Triple Diffused
Low Frequency Power Amplifier

Absolute Maximum Ratings (Ta = 25°C)

Item	Symbol	Rating	Unit
Collector to base voltage	V_{CB0}	120	V
Collector to emitter voltage	V_{CE0}	120	V
Emitter to base voltage	V_{EBO}	7	V
Collector current	I_C	10	A
Collector peak current	$i_{C(peak)}$	15	A
Collector power dissipation	P_C	2	W
	P_C^{-1}	30	
Junction temperature	T_j	150	°C
Storage temperature	T_{stg}	-55 to +150	°C
C to E diode forward current	I_D^{-1}	10	A

Note: 1. Value at $T_C = 25^\circ\text{C}$.

TO-220FM



1. Base
2. Collector
3. Emitter

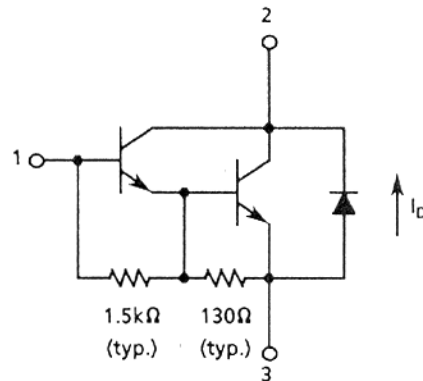

Electrical Characteristics (Ta = 25°C)

Item	Symbol	Min	Typ	Max	Unit	Test condition
Collector to base breakdown voltage	$V_{(BR)CB0}$	120	—	—	V	$I_C = 0.1 \text{ mA}, I_E = 0$
Collector to emitter breakdown voltage	$V_{(BR)CE0}$	120	—	—	V	$I_C = 25 \text{ mA}, R_{BE} = \infty$
Emitter to base breakdown voltage	$V_{(BR)EBO}$	7	—	—	V	$I_E = 50 \text{ mA}, I_C = 0$
Collector cutoff current	I_{CB0}	—	—	10	μA	$V_{CB} = 100 \text{ V}, I_E = 0$
	I_{CE0}	—	—	10		$V_{CE} = 100 \text{ V}, R_{BE} = \infty$
DC current transfer ratio	h_{FE}	1000	—	20000		$V_{CE} = 3 \text{ V}, I_C = 5 \text{ A}^{-1}$
Collector to emitter saturation voltage	$V_{CE(sat)1}$	—	—	1.5	V	$I_C = 5 \text{ A}, I_B = 10 \text{ mA}^{-1}$
	$V_{CE(sat)2}$	—	—	3.0		$I_C = 10 \text{ A}, I_B = 100 \text{ mA}^{-1}$

2SD2105

Electrical Characteristics (Ta = 25°C) (cont)

Item	Symbol	Min	Typ	Max	Unit	Test condition
Base to emitter saturation voltage	$V_{BE(sat)1}$	—	—	2.0	V	$I_C = 5\text{ A}, I_B = 10\text{ mA}^{\dagger}$
	$V_{BE(sat)2}$	—	—	3.5		$I_C = 10\text{ A}, I_B = 100\text{ mA}^{\dagger}$
C to E diode forward current	V_D	—	—	3.0	V	$I_D = 10\text{ A}^{\dagger}$

Note: 1. Pulse Test.

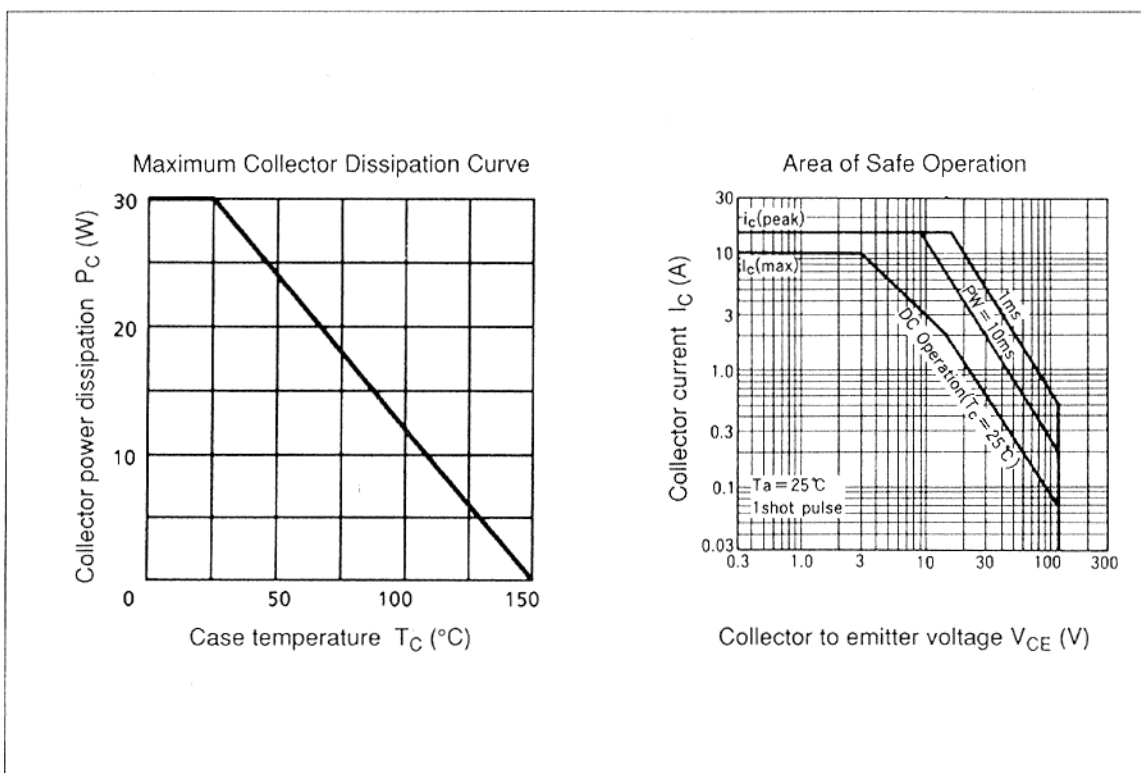

Typical Output Characteristics

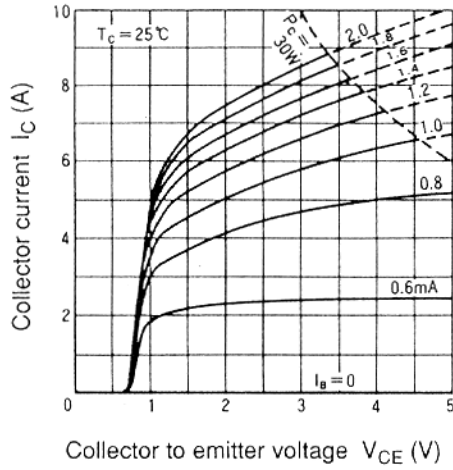

DC Current Transfer Ratio vs. Collector Current

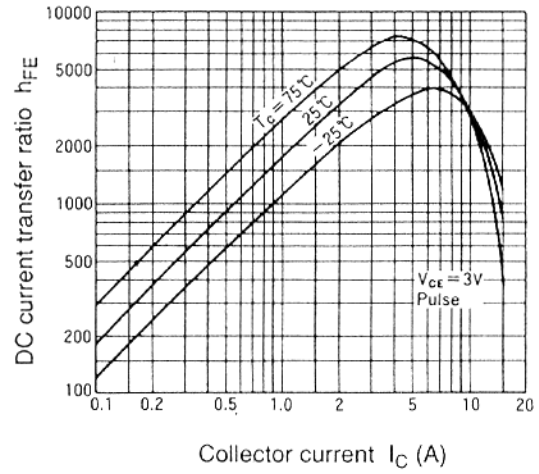

Saturation Voltage vs. Collector Current

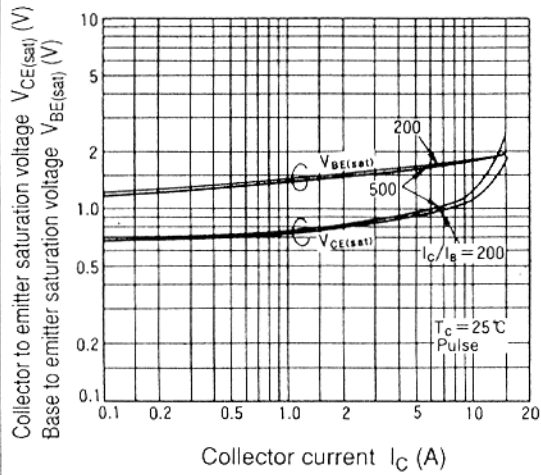

2SD2105

