

2SD2491, 2SD2492

Silicon NPN Epitaxial

Application

Low Frequency High Voltage Amplifier

Features

- Isolated package
TO-126FM

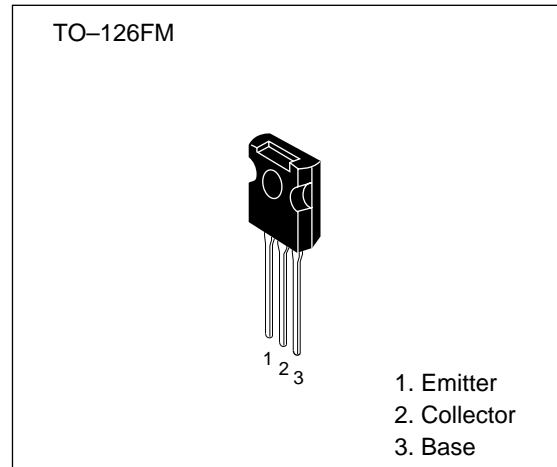

Absolute Maximum Ratings (Ta = 25°C)

Item	Symbol	2SD2491	2SD2492	Unit
Collector to base voltage	V_{CBO}	160	200	V
Collector to emitter voltage	V_{CEO}	160	200	V
Emitter to base voltage	V_{EBO}	5	5	V
Collector current	I_C	100	100	mA
Collector power dissipation	P_C	1.35	1.35	W
Collector power dissipation	P_C^{*1}	8	8	W
Junction temperature	T_J	150	150	°C
Storage temperature	T_{stg}	-55 to +150	-55 to +150	°C

Note: 1. Value at $T_c = 25^\circ\text{C}$

2SD2491, 2SD2492

Electrical Characteristics (Ta = 25°C)

Item	Symbol	2SD2491			2SD2492			Unit	Test conditions
		Min	Typ	Max	Min	Typ	Max		
Collector to base breakdown voltage	$V_{(BR)CBO}$	160	—	—	200	—	—	V	$I_C = 10 \mu A,$ $I_E = 0$
Collector to emitter breakdown voltage	$V_{(BR)CEO}$	160	—	—	200	—	—	V	$I_C = 1 \text{ mA},$ $R_{BE} = \infty$
Emitter to base breakdown voltage	$V_{(BR)EBO}$	5	—	—	5	—	—	V	$I_E = 10 \mu A,$ $I_C = 0$
Collector cutoff current	I_{CBO}	—	—	10	—	—	—	μA	$V_{CB} = 140 \text{ V},$ $I_E = 0$
		—	—	—	—	—	10	μA	$V_{CB} = 160 \text{ V},$ $I_E = 0$
DC current transfer ratio	h_{FE1}^{*1}	60	—	320	60	—	320		$V_{CE} = 5 \text{ V},$ $I_C = 10 \text{ mA}$
DC current transfer ratio	h_{FE2}	30	—	—	30	—	—		$V_{CE} = 5 \text{ V},$ $I_C = 1 \text{ mA}$
Base to emitter voltage	V_{BE}	—	—	1.5	—	—	1.5	V	$V_{CE} = 5 \text{ V},$ $I_C = 10 \text{ mA}$
Collector to emitter saturation voltage	$V_{CE(sat)}$	—	—	2	—	—	2	V	$I_C = 30 \text{ mA},$ $I_B = 3 \text{ mA}$
Gain bandwidth product	f_T	—	140	—	—	140	—	MHz	$V_{CE} = 5 \text{ V},$ $I_C = 10 \text{ mA}$
Collector output capacitance	C_{ob}	—	3.8	—	—	3.8	—	pF	$V_{CB} = 10 \text{ V},$ $I_E = 0$ $f = 1 \text{ MHz}$

Note: 1. The 2SD2491 and 2SD2492 are grouped by h_{FE1} and its specification is as follows.

B	C	D
60 to 120	100 to 200	160 to 320

See characteristic curves of 2SD1609, 2SD1610.

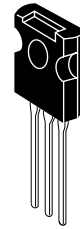
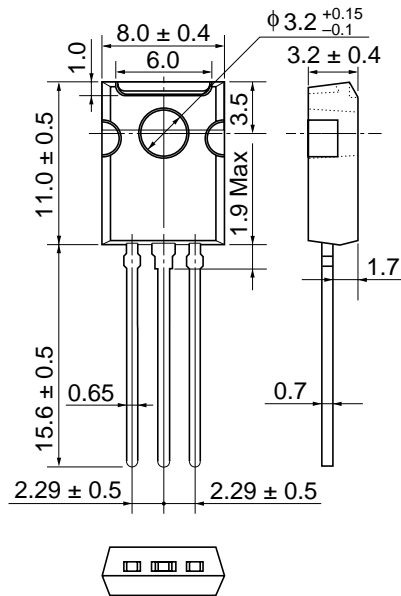
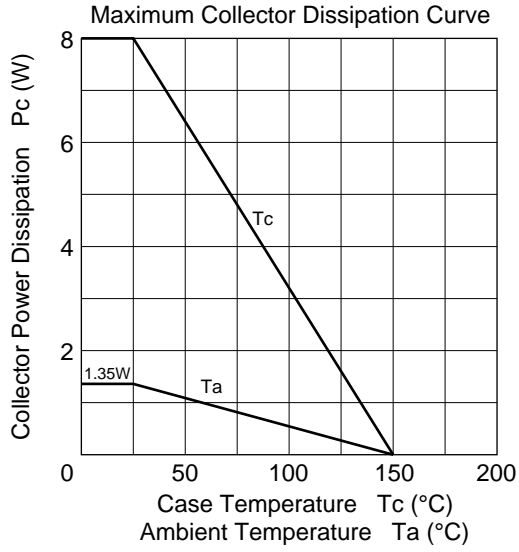

Hitachi Code	TO-126FM
EIAJ	—
JEDEC	—