

2SJ361

Silicon P-Channel MOS FET

Application

High speed power switching

Features

- Low on-resistance
- High speed switching
- Low drive current
- 2.5 V gate drive device can be driven from 3 V source

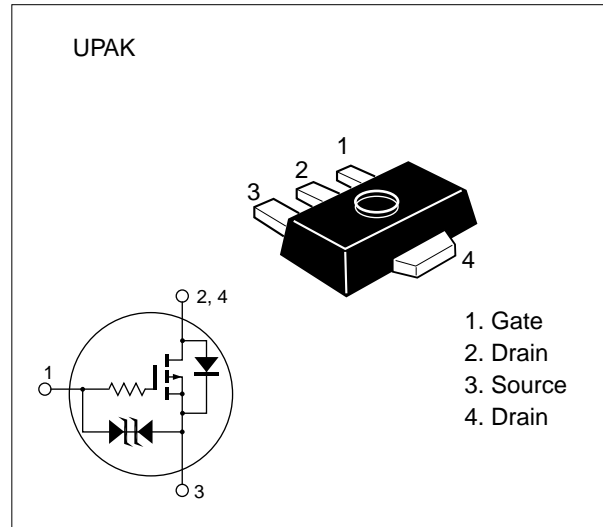

Table 1 Absolute Maximum Ratings (Ta = 25°C)

Item	Symbol	Ratings	Unit
Drain to source voltage	V _{DSS}	-20	V
Gate to source voltage	V _{GSS}	±20	V
Drain current	I _D	-2	A
Drain peak current	I _{D(pulse)} *	-4	A
Body-drain diode reverse drain current	I _{DR}	-2	A
Channel dissipation	P _{ch} **	1	W
Channel temperature	T _{ch}	150	°C
Storage temperature	T _{stg}	-55 to +150	°C

* PW ≤ 10 μs, duty cycle ≤ 1 %

** Value on the alumina ceramic board (12.5 x 20 x 0.7mm)

*** Marking is "RY".

Table 2 Electrical Characteristics (Ta = 25°C)

Item	Symbol	Min	Typ	Max	Unit	Test conditions
Drain to source breakdown voltage	$V_{(BR)DSS}$	-20	—	—	V	$I_D = -10 \text{ mA}$, $V_{GS} = 0$
Gate to source breakdown voltage	$V_{(BR)GSS}$	±20	—	—	V	$I_G = \pm 100 \mu\text{A}$, $V_{DS} = 0$
Gate to source leak current	I_{GSS}	—	—	±10	μA	$V_{GS} = \pm 16 \text{ V}$, $V_{DS} = 0$
Zero gate voltage drain current	I_{DSS}	—	—	-10	μA	$V_{DS} = -16 \text{ V}$, $V_{GS} = 0$
Gate to source cutoff voltage	$V_{GS(off)}$	-0.5	—	-1.5	V	$I_D = -1 \text{ mA}$, $V_{DS} = -10 \text{ V}$
Static drain to source on state resistance	$R_{DS(on)}$	—	0.28	0.4	Ω	$I_D = -1 \text{ A}$ $V_{GS} = -10 \text{ V}$
		—	0.85	1.5	Ω	$I_D = -0.4 \text{ A}$ $V_{GS} = -2.5 \text{ V}$
Forward transfer admittance	$ y_{fs} $	0.15	0.3	—	S	$I_D = -10 \text{ A}$ $V_{DS} = -10 \text{ V}$
Input capacitance	C_{iss}	—	3.2	—	pF	$V_{DS} = -10 \text{ V}$
Output capacitance	C_{oss}	—	130	—	pF	$V_{GS} = 0$
Reverse transfer capacitance	C_{rss}	—	0.6	—	pF	f = 1 MHz
Turn-on delay time	$t_{d(on)}$	—	350	—	ns	$I_D = -1 \text{ A}$
Rise time	t_r	—	1650	—	ns	$V_{GS} = -10 \text{ V}$
Turn-off delay time	$t_{d(off)}$	—	7280	—	ns	$R_L = 10 \Omega$
Fall time	t_f	—	6950	—	ns	
Body-drain diode forward voltage	V_{DF}	—	-1.0	—	V	$I_F = -2 \text{ A}$, $V_{GS} = 0$
Body-drain diode reverse recovery time	t_{rr}	—	530	—	μs	$I_F = -2 \text{ A}$, $V_{GS} = 0$, $diF / dt = 20 \text{ A} / \mu\text{s}$

* Pulse Test

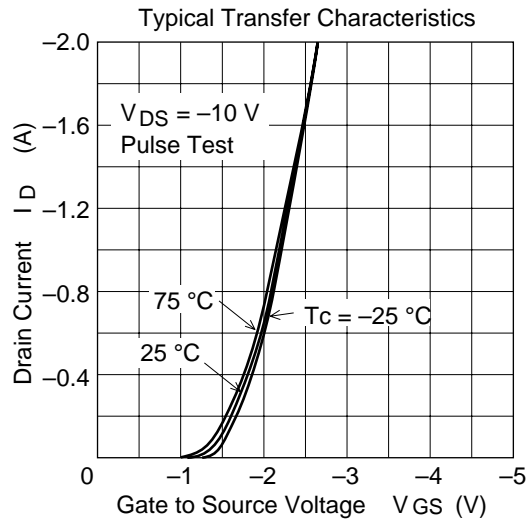
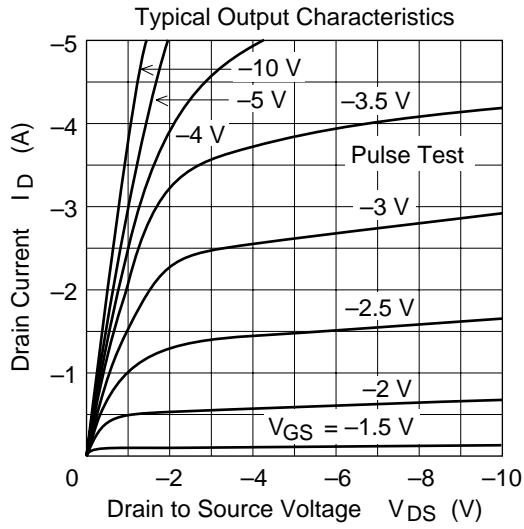
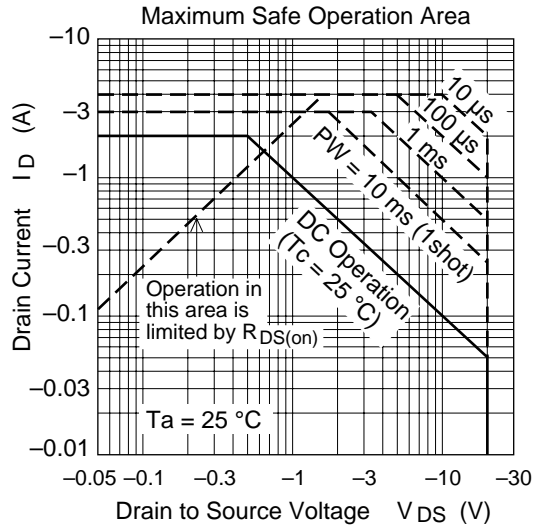
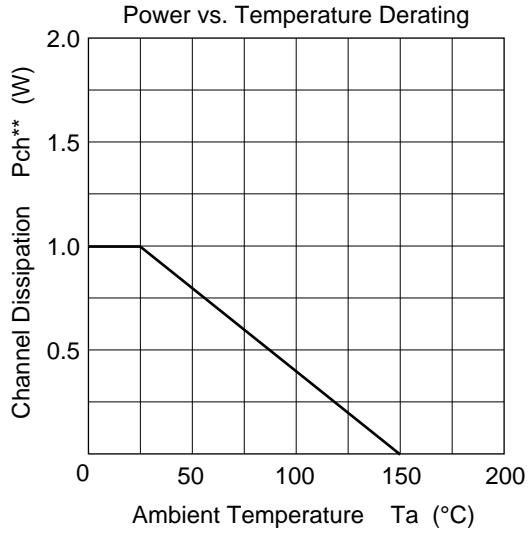

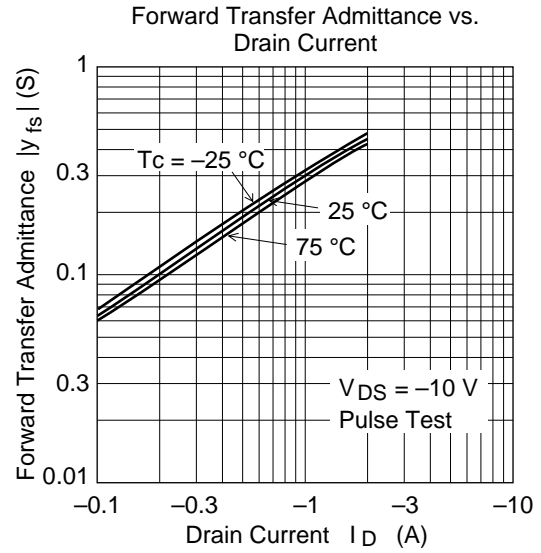
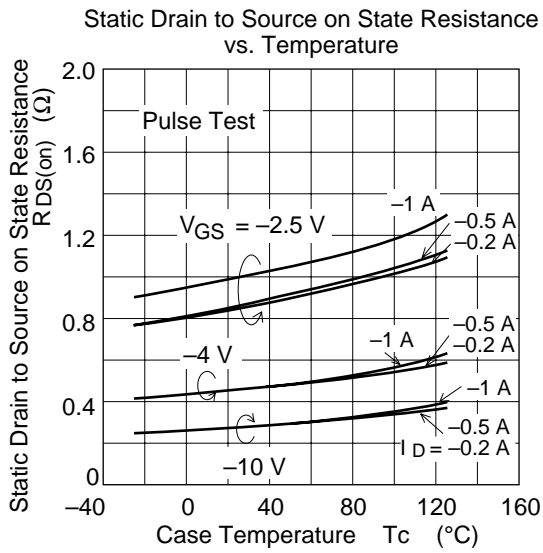
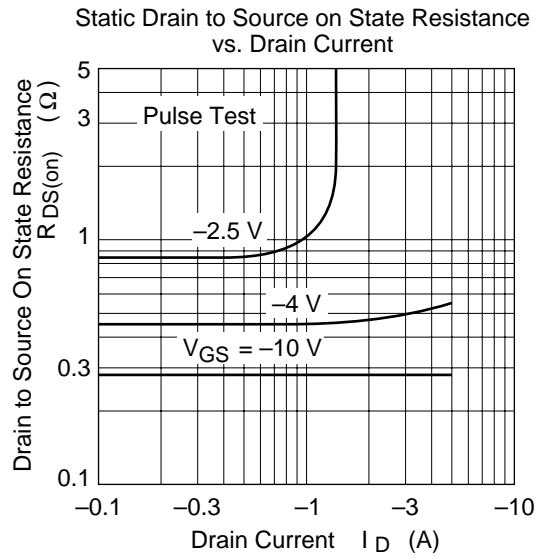
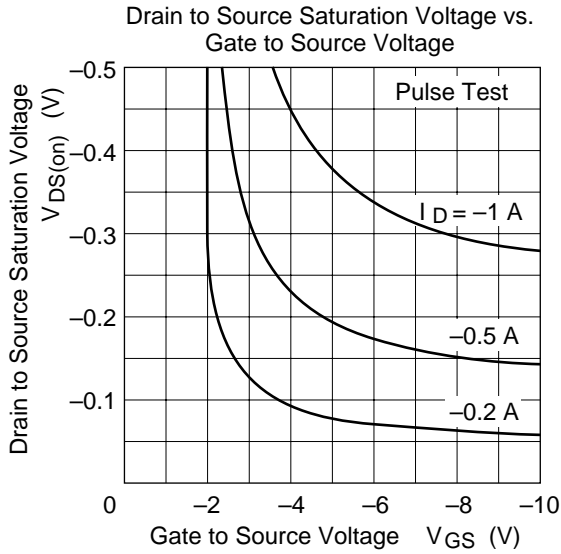

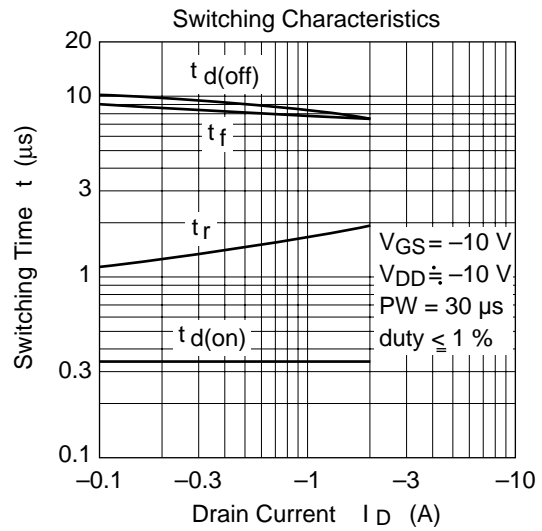
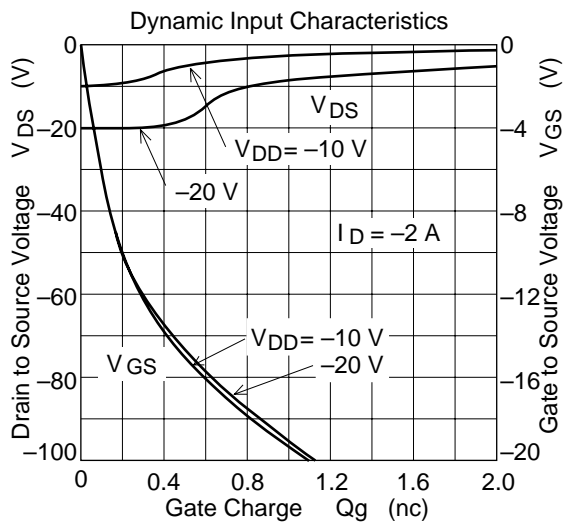
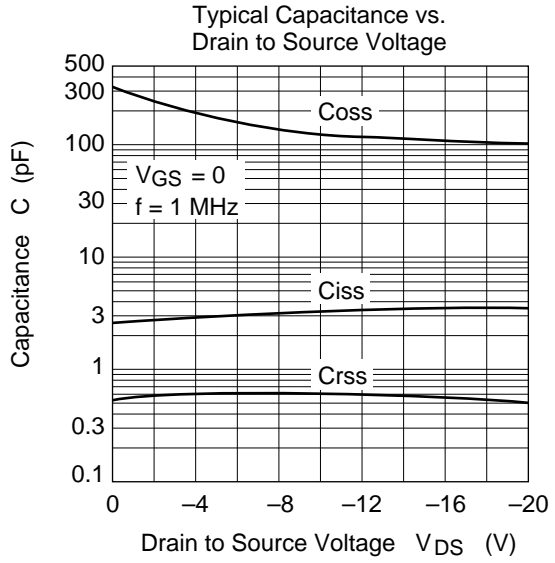
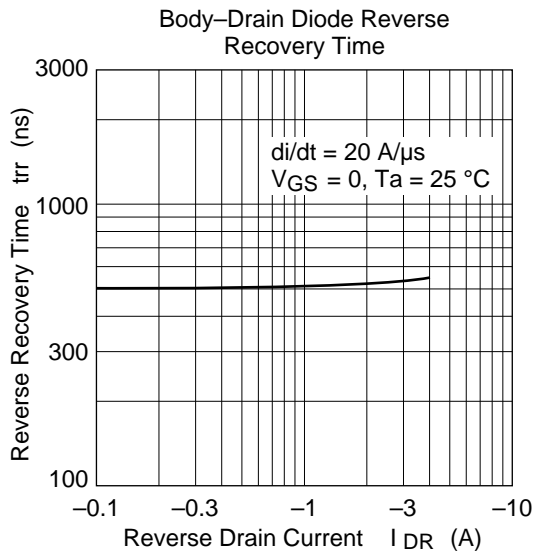

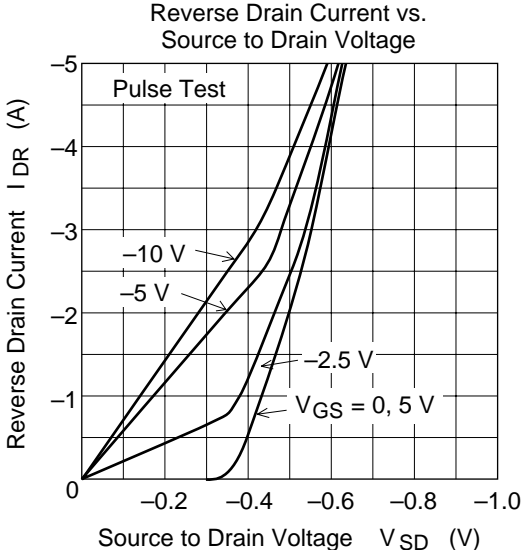

Switching Time Test Circuit

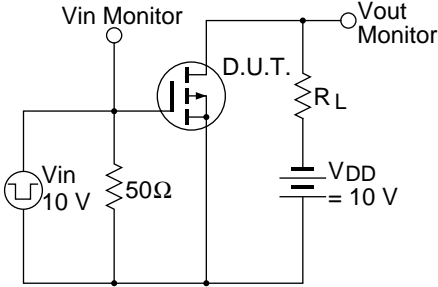

Waveforms

