

2SK1336

SILICON N-CHANNEL MOS FET HIGH SPEED POWER SWITCHING

■ FEATURES

- Low On-Resistance
- High Speed Switching
- Low Drive Current
- 4 V Gate Drive Device
 - Can be driven from 5 V source
- Suitable for Motor Drive, DC-DC Converter, Power Switch and Solenoid Drive

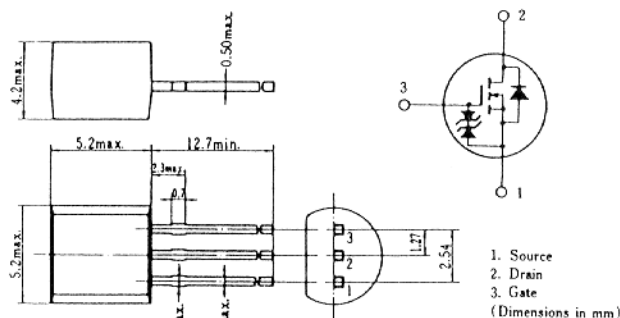

(JEDEC TO-92)

■ ABSOLUTE MAXIMUM RATINGS ($T_a = 25^\circ\text{C}$)

Item	Symbol	Rating	Unit
Drain-Source Voltage	V_{DS}	60	V
Gate-Source Voltage	V_{GS}	± 20	V
Drain Current	I_D	0.3	A
Drain Peak Current	$I_{D(pulse)}$ *	1.2	A
Body-Drain Diode			
Reverse Drain Current	I_{DR}	0.3	A
Channel Dissipation	P_{ch}	400	mW
Channel Temperature	T_{ch}	150	$^\circ\text{C}$
Storage Temperature	T_{stg}	$-55 \sim +150$	$^\circ\text{C}$

*PW $\leq 10\mu\text{s}$, duty cycle $\leq 1\%$

POWER VS. TEMPERATURE DERATING

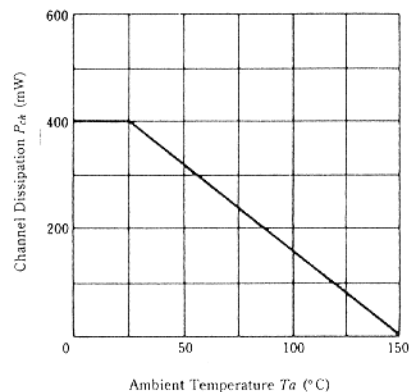

■ ELECTRICAL CHARACTERISTICS ($T_a = 25^\circ\text{C}$)

Item	Symbol	Test Condition	min.	typ.	max.	Unit
Drain-Source Breakdown Voltage	$V_{(BR)DS}$	$I_D = 10\text{mA}$, $V_{GS} = 0$	60	—	—	V
Gate-Source Breakdown Voltage	$V_{(BR)GS}$	$I_G = \pm 100\mu\text{A}$, $V_{DS} = 0$	± 20	—	—	V
Gate-Source Leak Current	I_{GSS}	$V_{GS} = \pm 16\text{V}$, $V_{DS} = 0$	—	—	± 10	μA
Zero Gate Voltage Drain Current	I_{DSS}	$V_{DS} = 50\text{V}$, $V_{GS} = 0$	—	—	50	μA
Gate-Source Cutoff Voltage	$V_{GS(off)}$	$I_D = 1\text{mA}$, $V_{DS} = 10\text{V}$	1.0	—	2.0	V
Static Drain-Source on State Resistance	$R_{DS(on)}$	$I_D = 0.2\text{A}$, $V_{DS} = 10\text{V}$ *	—	1.3	1.7	Ω
		$I_D = 0.2\text{A}$, $V_{GS} = 4\text{V}$ *	—	1.8	2.5	
Forward Transfer Admittance	$ y_{fs} $	$I_D = 0.2\text{A}$, $V_{DS} = 10\text{V}$ *	0.22	0.35	—	S
Input Capacitance	C_{iss}	$V_{DS} = 10\text{V}$, $V_{GS} = 0$, $f = 1\text{MHz}$	—	33	—	pF
Output Capacitance	C_{oss}		—	17	—	pF
Reverse Transfer Capacitance	C_{rss}		—	5	—	pF
Turn-on Delay Time	$t_{d(on)}$		—	2	—	ns
Rise Time	t_r	$I_D = 0.2\text{A}$, $V_{GS} = 10\text{V}$, $R_L = 150\Omega$	—	4	—	ns
Turn-off Delay Time	$t_{d(off)}$		—	18	—	ns
Fall Time	t_f		—	16	—	ns
Body-Drain Diode Forward Voltage	V_{DF}	$I_F = 0.3\text{A}$, $V_{GS} = 0$	—	0.9	—	V
Body-Drain Diode Reverse Recovery Time	t_{rr}	$I_F = 0.3\text{A}$, $V_{GS} = 0$, $di/dt = 50\text{A}/\mu\text{s}$	—	45	—	ns

* Pulse Test

MAXIMUM SAFE OPERATION AREA

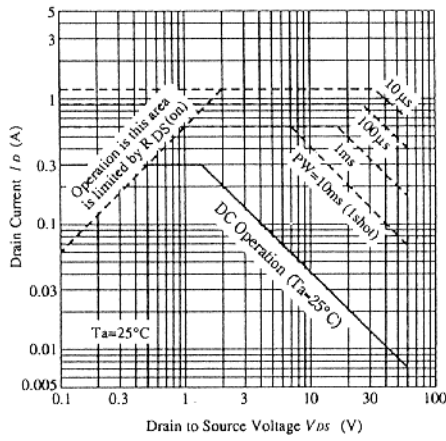

TYPICAL OUTPUT CHARACTERISTICS

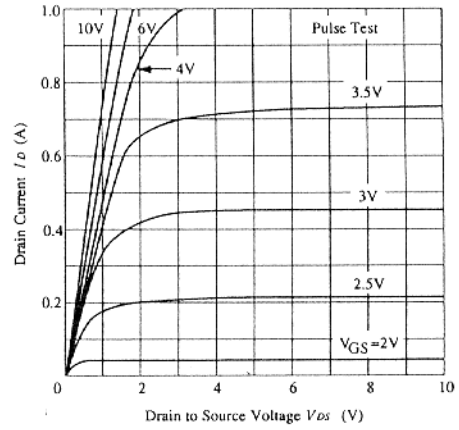

TYPICAL TRANSFER CHARACTERISTICS

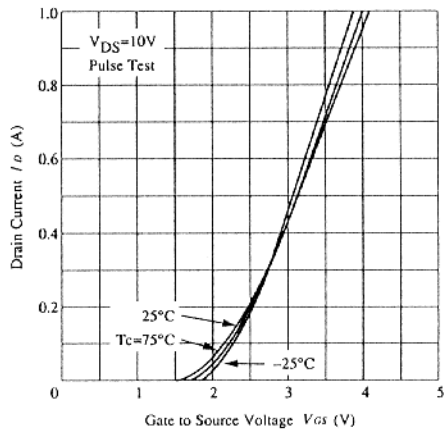

DRAIN-SOURCE SATURATION VOLTAGE VS. GATE-SOURCE VOLTAGE

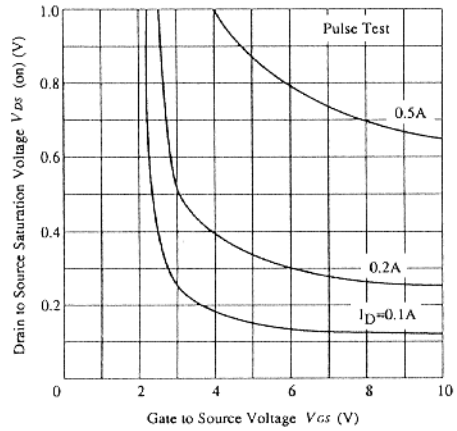

STATIC DRAIN-SOURCE ON STATE RESISTANCE VS. DRAIN CURRENT

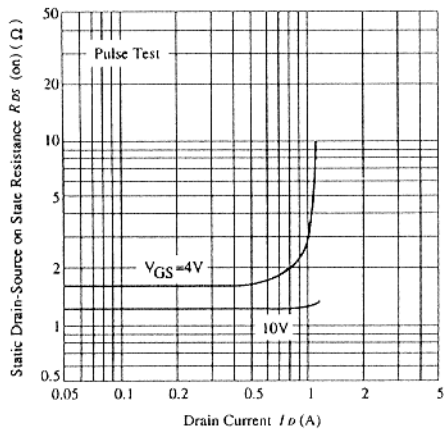

STATIC DRAIN-SOURCE ON STATE RESISTANCE VS. TEMPERATURE

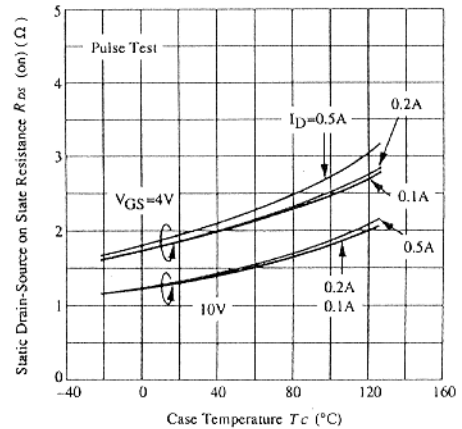

FORWARD TRANSFER ADMITTANCE VS. DRAIN CURRENT

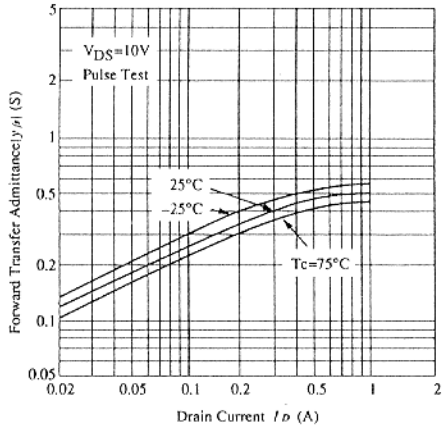

BODY-DRAIN DIODE REVERSE RECOVERY TIME

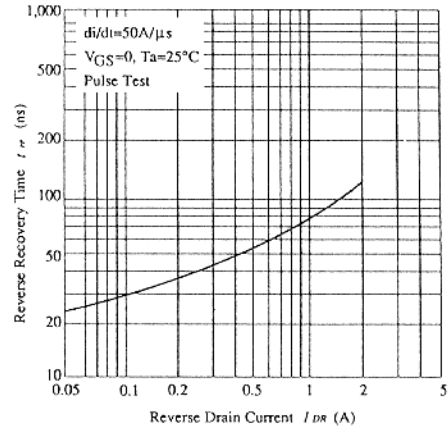

TYPICAL CAPACITANCE VS. DRAIN-SOURCE VOLTAGE

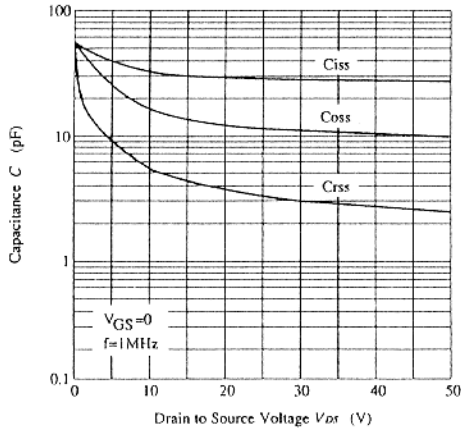

DYNAMIC INPUT CHARACTERISTICS

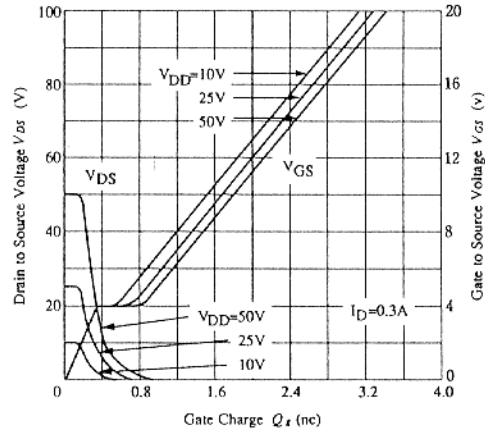

SWITCHING CHARACTERISTICS

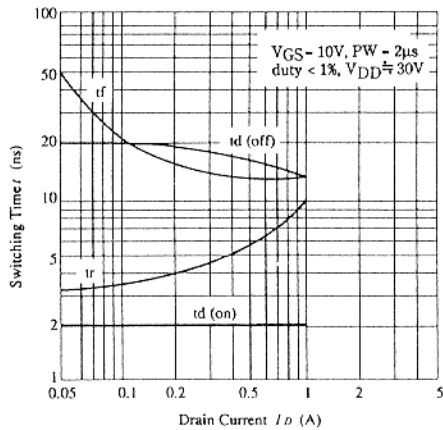

REVERSE DRAIN CURRENT VS. SOURCE TO DRAIN VOLTAGE

