

2SK1836, 2SK1837

Silicon N Channel MOS FET

Application

High speed power switching

Features

- Low on-resistance
- High speed switching
- Low drive current
- No secondary breakdown
- Suitable for switching regulator, DC-DC converter

Table 1 Ordering Information

Type No	V_{DSS}
2SK1836	450V
2SK1837	500V

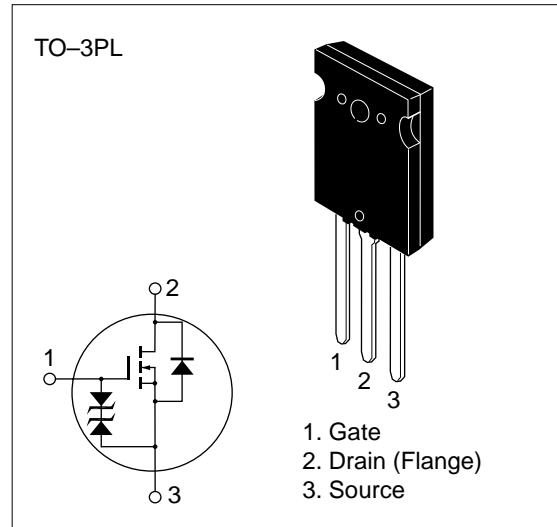

Table 2 Absolute Maximum Ratings ($T_a = 25^\circ\text{C}$)

Item		Symbol	Ratings	Unit
Drain to source voltage	K1836	V_{DSS}	450	V
	K1837		500	
Gate to source voltage		V_{GSS}	± 30	V
Drain current		I_D	50	A
Drain peak current		$I_{D(\text{pulse})}^*$	200	A
Body-drain diode reverse drain current		I_{DR}	50	A
Channel dissipation		P_{ch}^{**}	250	W
Channel temperature		T_{ch}	150	$^\circ\text{C}$
Storage temperature		T_{stg}	-55 to +150	$^\circ\text{C}$

* $PW \leq 10 \mu\text{s}$, duty cycle $\leq 1\%$

** Value at $T_c = 25^\circ\text{C}$

Table 3 Electrical Characteristics (Ta = 25°C)

Item	Symbol	Min	Typ	Max	Unit	Test conditions
Drain to source breakdown voltage	K1836	450	—	—	V	ID = 10 mA, VGS = 0
	K1837	500	—	—		
Gate to source breakdown voltage	V(BR)GSS	±30	—	—	V	IG = ±100 μA, VDS = 0
Gate to source leak current	IGSS	—	—	±10	μA	VGS = ±25 V, VDS = 0
Zero gate voltage drain current	K1836	—	—	250	μA	VDS = 360 V, VGS = 0
	K1837	—	—	—		VDS = 400 V, VGS = 0
Gate to source cutoff voltage	VGS(off)	2.0	—	3.0	V	ID = 1 mA, VDS = 10 V
Static drain to source on state resistance	K1836	—	0.08	0.10	Ω	ID = 25 A VGS = 10 V *
	K1837	—	0.085	0.11		
Forward transfer admittance	yfs	22	35	—	S	ID = 25 A VDS = 10 V *
Input capacitance	Ciss	—	8150	—	pF	VDS = 10 V
Output capacitance	Coss	—	2100	—	pF	VGS = 0
Reverse transfer capacitance	Crss	—	180	—	pF	f = 1 MHz
Turn-on delay time	td(on)	—	80	—	ns	ID = 25 A
Rise time	tr	—	250	—	ns	VGS = 10 V
Turn-off delay time	td(off)	—	550	—	ns	RL = 1.2 Ω
Fall time	tf	—	220	—	ns	
Body-drain diode forward voltage	VDF	—	1.1	—	V	IF = 50 A, VGS = 0
Body-drain diode reverse recovery time	trr	—	620	—	ns	IF = 50 A, VGS = 0, diF / dt = 100 A / μs

* Pulse Test

Power vs. Temperature Derating

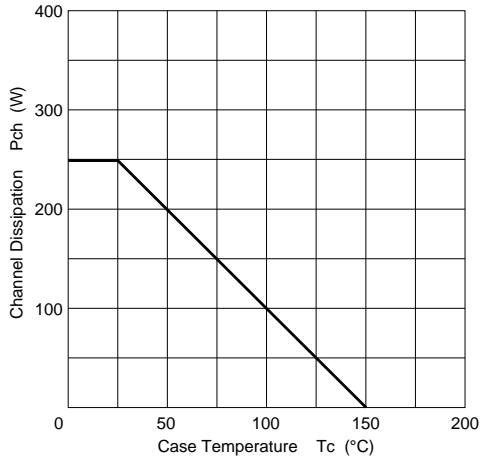

Maximum Safe Operation Area

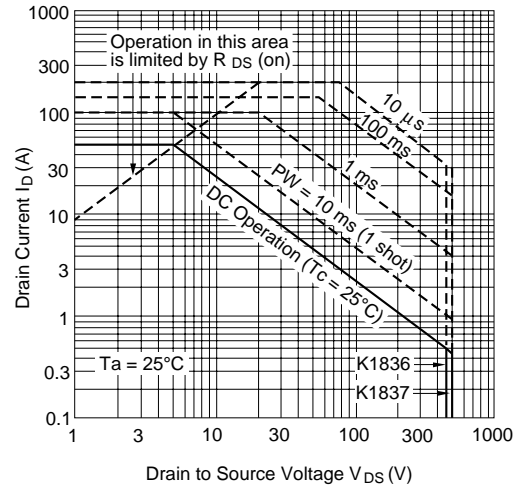

Typical Output Characteristics

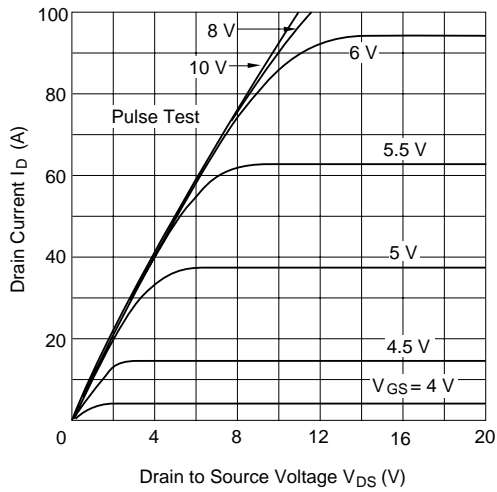

Typical Transfer Characteristics

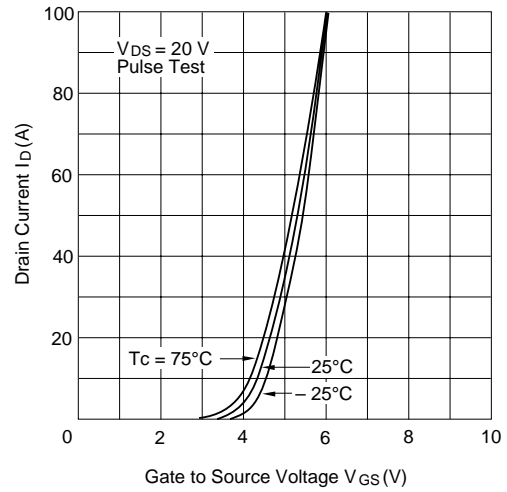

Drain-Source Saturation Voltage vs. Gate-Source Voltage

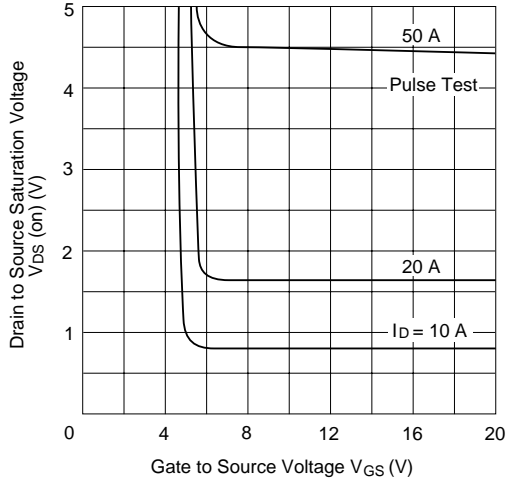

Static Drain-Source on State Resistance vs. Drain Current

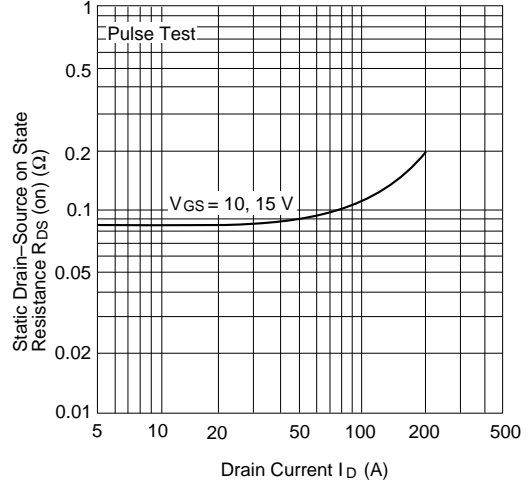

Static Drain-Source on State Resistance vs. Temperature

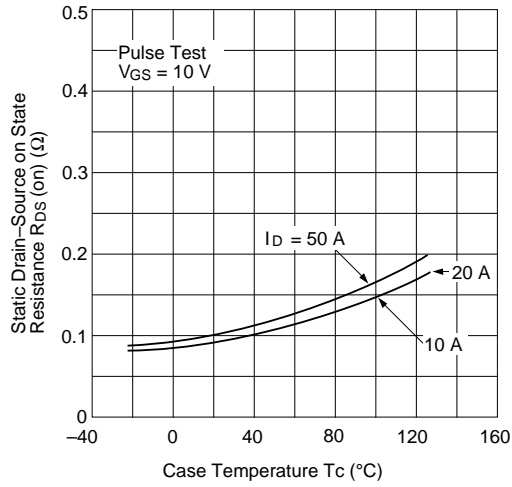

Forward Transfer Admittance vs. Drain Current

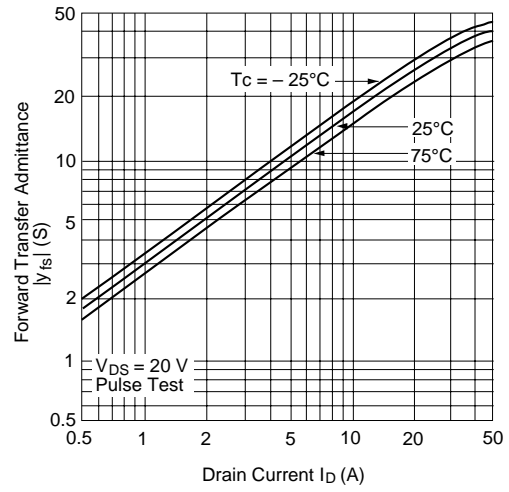

Body-Drain Diode Reverse Recovery Time

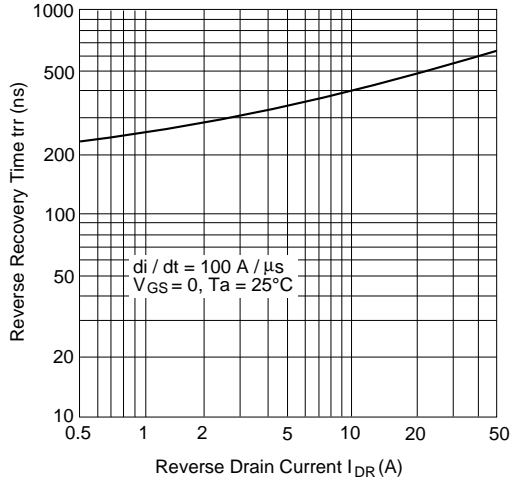

Typical Capacitance vs. Drain-Source Voltage

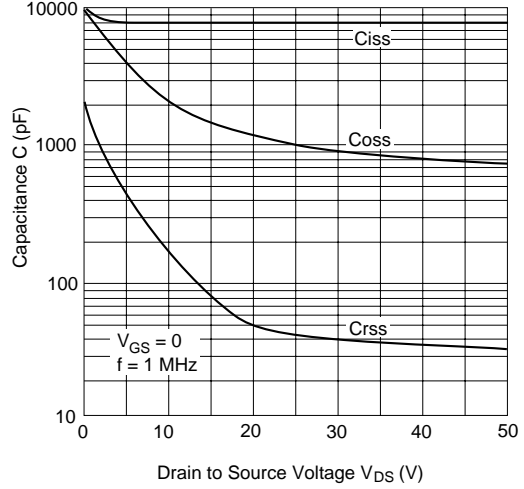

Dynamic Input Characteristics

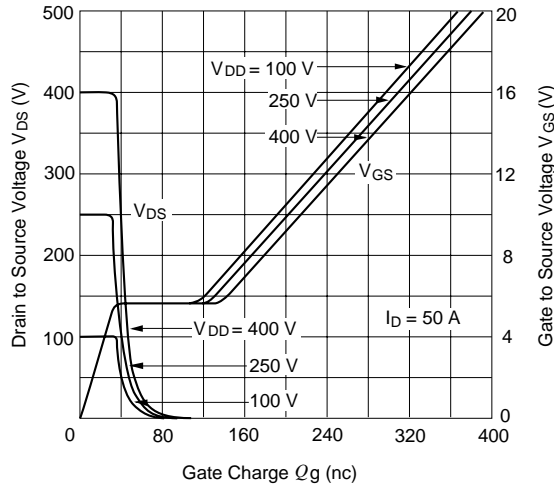

Switching Characteristics

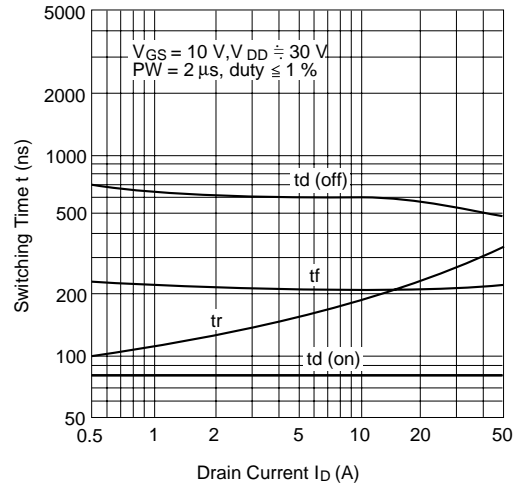

Reverse Drain Current vs. Source to Drain Voltage

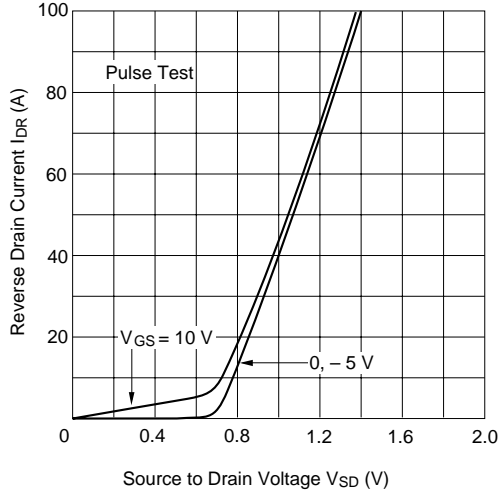

Normalized Transient Thermal Impedance vs. Pulse Width

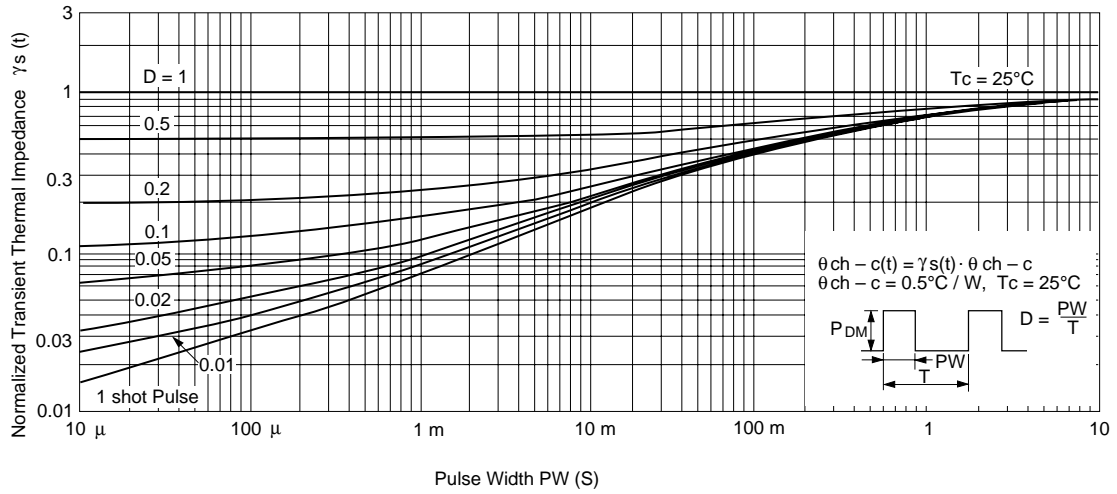

Switching Time Test Circuit

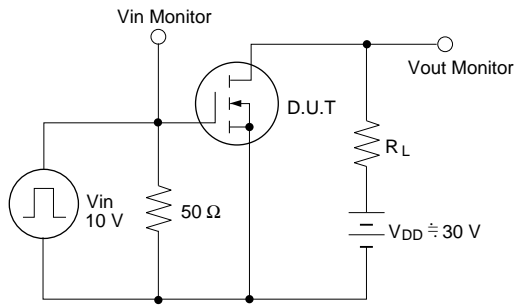

Waveforms

