

SWITCHING
N-CHANNEL POWER MOS FET
INDUSTRIAL USE

DESCRIPTION

The 2SK2139 is N-Channel Power MOS Field Effect Transistor designed for high voltage switching applications.

FEATURES

- Low On-Resistance
 $R_{DS(on)} = 1.5 \Omega \text{ MAX. (} V_{GS} = 10 \text{ V, } I_D = 2.5 \text{ A)}$
- Low C_{iss} $C_{iss} = 930 \text{ pF TYP.}$
- High Avalanche Capability Ratings
- Isolate TO-220 (MP-45F) Package

ABSOLUTE MAXIMUM RATINGS ($T_A = 25 \text{ }^\circ\text{C}$)

Drain to Source Voltage	V_{DS}	600	V
Gate to Source Voltage	V_{GS}	± 30	V
Drain Current (DC)	$I_{D(DC)}$	± 5.0	A
Drain Current (pulse)*	$I_{D(pulse)}$	± 20	A
Total Power Dissipation ($T_c = 25 \text{ }^\circ\text{C}$)	P_{T1}	35	W
Total Power Dissipation ($T_A = 25 \text{ }^\circ\text{C}$)	P_{T2}	2.0	W
Channel Temperature	T_{ch}	150	$^\circ\text{C}$
Storage Temperature	T_{stg}	-55 to +150	$^\circ\text{C}$
Single Avalanche Current**	I_{AS}	5.0	A
Single Avalanche Energy**	E_{AS}	8.3	mJ

* $PW \leq 10 \mu\text{s}$, Duty Cycle $\leq 1 \%$

** Starting $T_{ch} = 25 \text{ }^\circ\text{C}$, $R_G = 25 \Omega$, $V_{GS} = 20 \text{ V} \rightarrow 0$

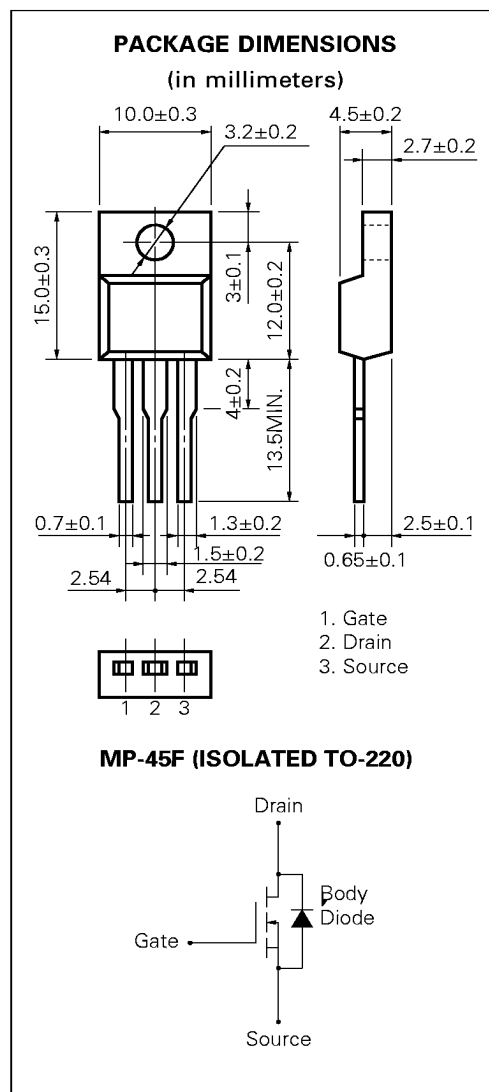

ELECTRICAL CHARACTERISTICS (TA = 25 °C)

CHARACTERISTIC	SYMBOL	MIN.	TYP.	MAX.	UNIT	TEST CONDITIONS
Drain to Source On-state Resistance	$R_{DS(on)}$		1.1	1.5	Ω	$V_{GS} = 10\text{ V}, I_D = 2.5\text{ A}$
Gate to Source Cutoff Voltage	$V_{GS(off)}$	2.5		3.5	V	$V_{DS} = 10\text{ V}, I_D = 1\text{ mA}$
Forward Transfer Admittance	$ y_{fs} $	1.5			S	$V_{DS} = 10\text{ V}, I_D = 2.5\text{ A}$
Drain Leakage Current	I_{DSS}			100	μA	$V_{DS} = 600\text{ V}, V_{GS} = 0$
Gate to Source Leakage Current	I_{GSS}			± 100	nA	$V_{GS} = \pm 30\text{ V}, V_{DS} = 0$
Input Capacitance	C_{iss}		930		pF	$V_{DS} = 10\text{ V}$ $V_{GS} = 0$ $f = 1\text{ MHz}$
Output Capacitance	C_{oss}		200		pF	
Reverse Transfer Capacitance	C_{rss}		40		pF	
Turn-On Delay Time	$t_{d(on)}$		20		ns	$V_{GS} = 10\text{ V}$ $V_{DD} = 150\text{ V}$ $I_D = 2.5\text{ A}, R_G = 10\ \Omega$ $R_L = 60\ \Omega$
Rise Time	t_r		10		ns	
Turn-Off Delay Time	$t_{d(off)}$		60		ns	
Fall Time	t_f		12		ns	
Total Gate Charge	Q_G		30		nC	$V_{GS} = 10\text{ V}$
Gate to Source Charge	Q_{GS}		6.0		nC	$I_D = 5.0\text{ V}$
Gate to Drain Charge	Q_{GD}		15		nC	$V_{DD} = 450\text{ V}$
Diode Forward Voltage	$V_{F(S-D)}$		1.0		V	$I_F = 5.0\text{ A}, V_{GS} = 0$
Reverse Recovery Time	t_{rr}		320		ns	$I_F = 5.0\text{ A}$
Reverse Recovery Charge	Q_{rr}		1.4		μC	$di/dt = 50\text{ A}/\mu\text{s}$

Test Circuit 1 Avalanche Capability

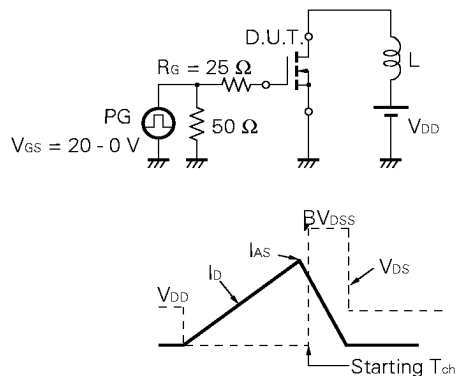

Test Circuit 2 Switching Time

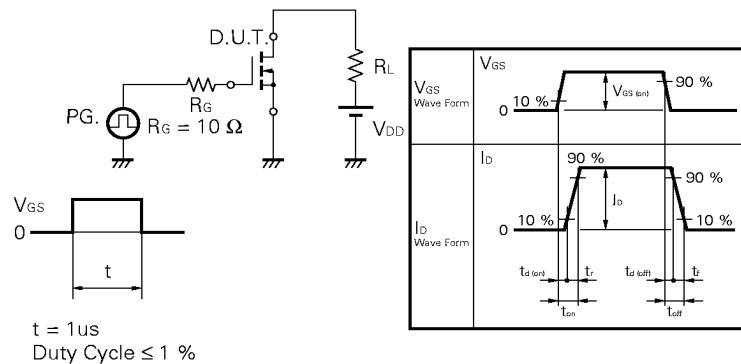

Test Circuit 3 Gate Charge

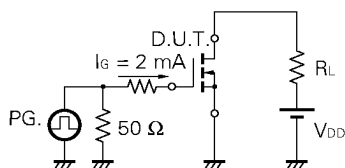

The application circuits and their parameters are for references only and are not intended for use in actual design-in's.

TYPICAL CHARACTERISTICS (T_A = 25 °C)

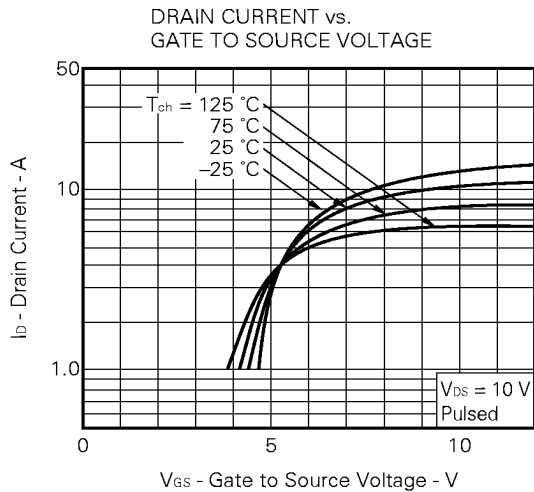
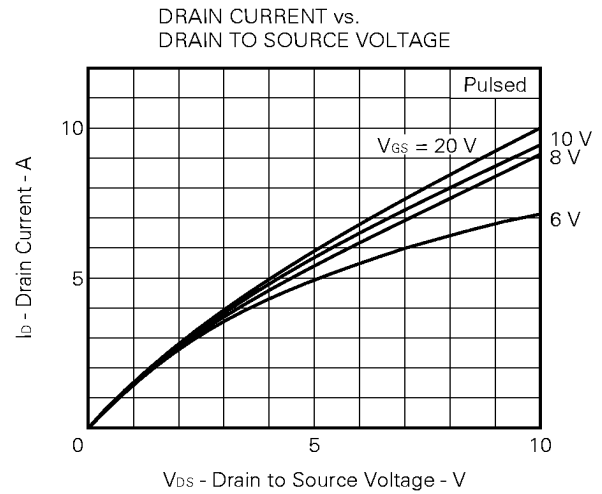
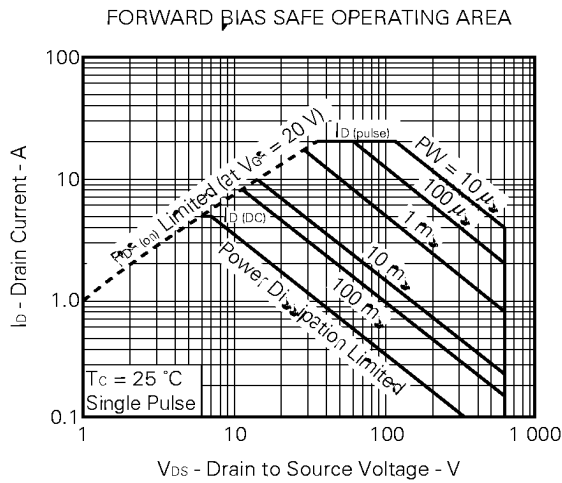
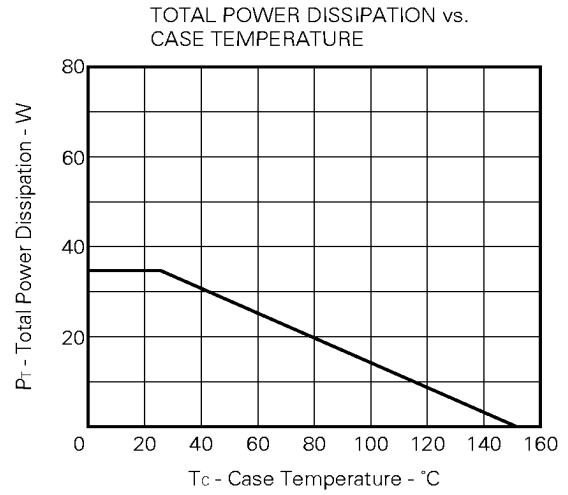
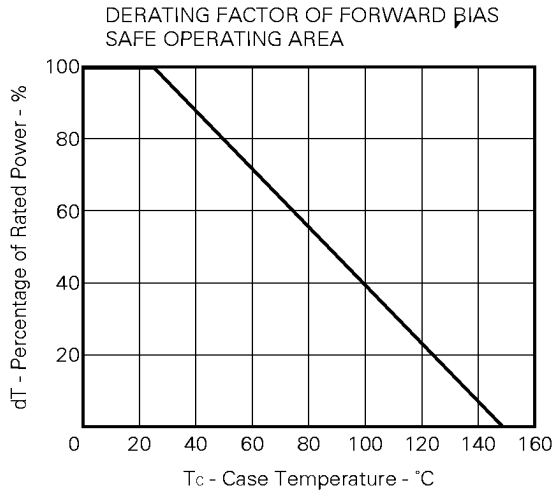

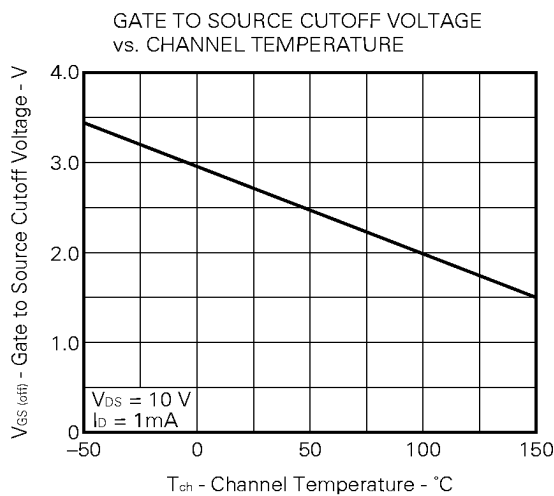
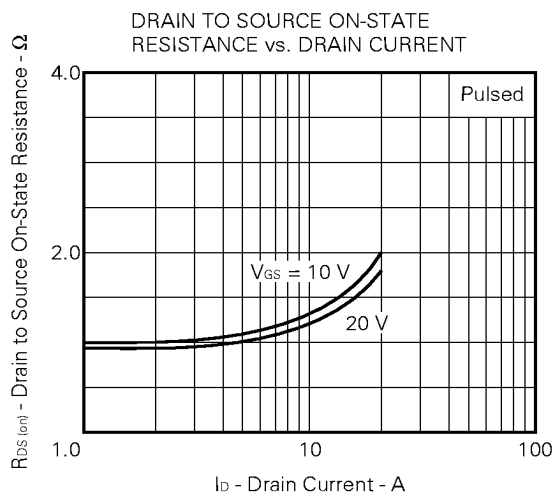
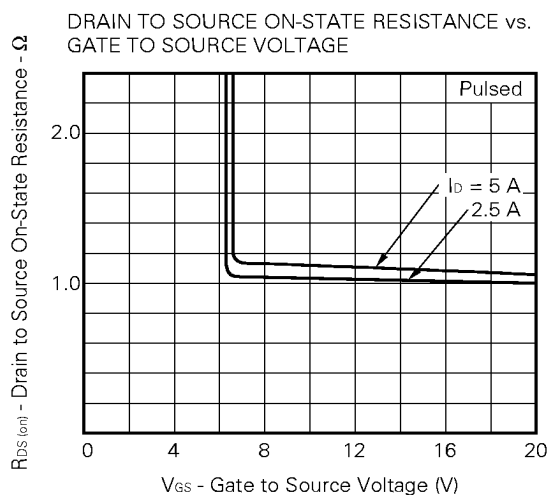
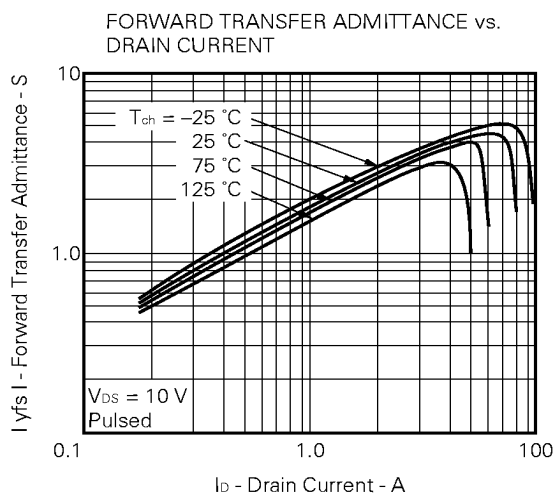
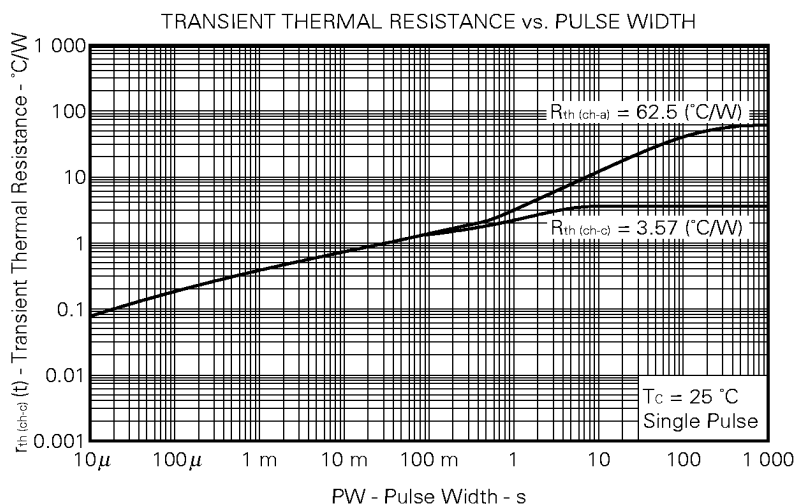

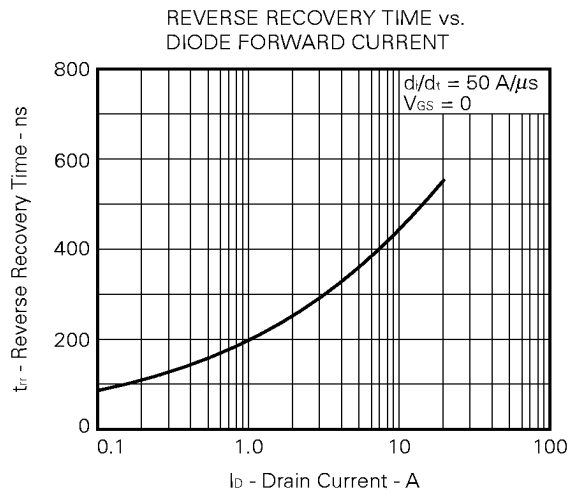
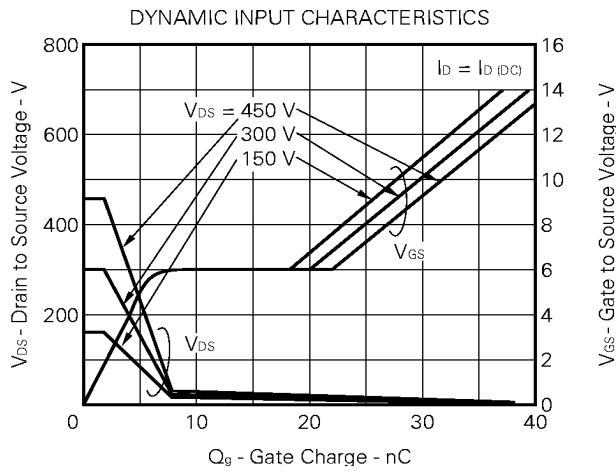
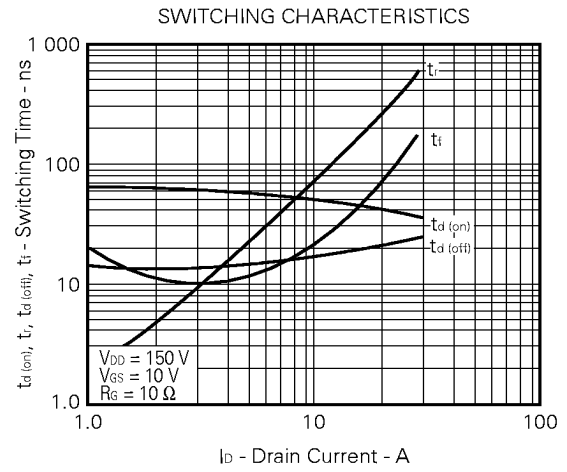
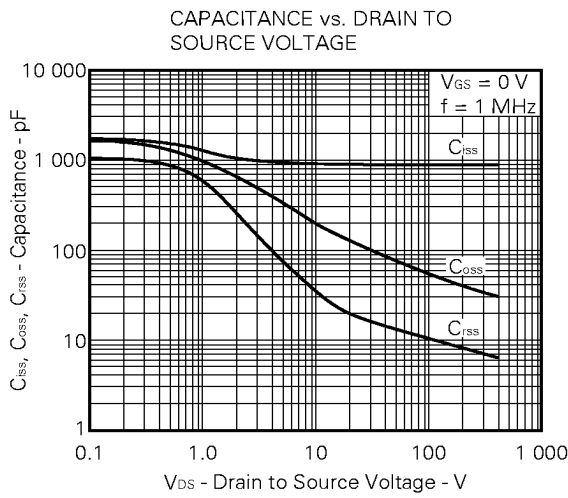
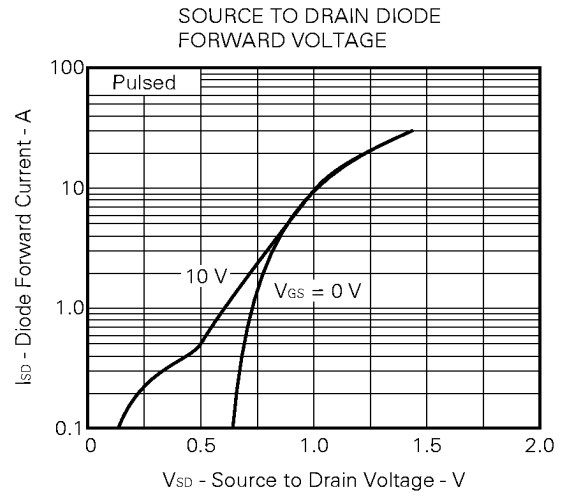
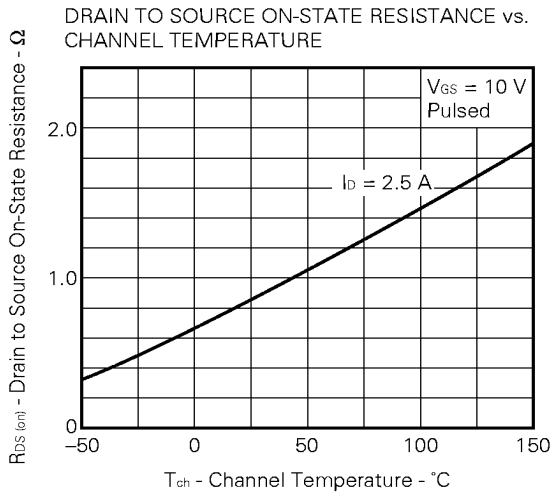

SINGLE AVALANCHE CURRENT vs. INDUCTIVE LOAD

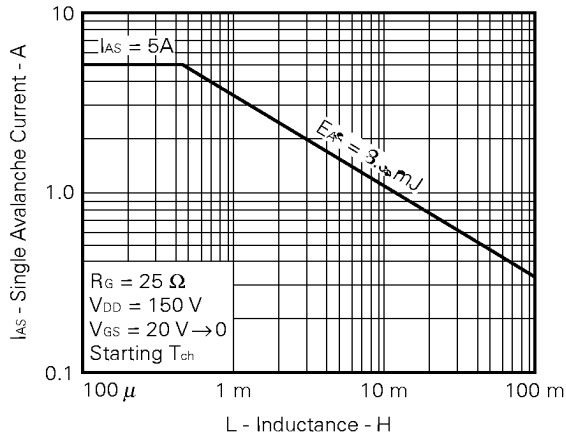

SINGLE AVALANCHE ENERGY vs. STARTING CHANNEL TEMPERATURE

