

## 2SK2175

### Silicon N Channel MOS FET

#### Application

High speed power switching

#### Features

- Low on-resistance
- High speed switching
- Low drive current
- 4 V gate drive device can be driven from 5 V source
- Suitable for Switching regulator, DC – DC converter
- Avalanche ratings

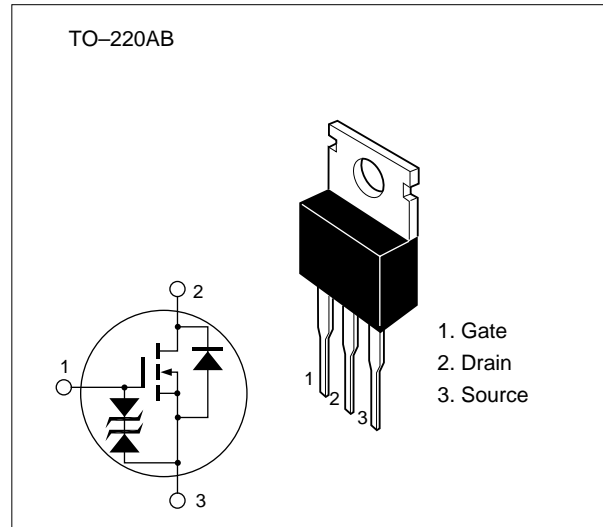

**Table 1 Absolute Maximum Ratings** (Ta = 25°C)

Item	Symbol	Ratings	Unit
Drain to source voltage	V <sub>DSS</sub>	60	V
Gate to source voltage	V <sub>GSS</sub>	±20	V
Drain current	I <sub>D</sub>	15	A
Drain peak current	I <sub>D(pulse)</sub> *	60	A
Body-drain diode reverse drain current	I <sub>DR</sub>	15	A
Avalanche current	I <sub>AP</sub> ***	10	A
Avalanche energy	E <sub>AR</sub> ***	8.5	mJ
Channel dissipation	P <sub>ch</sub> **	30	W
Channel temperature	T <sub>ch</sub>	150	°C
Storage temperature	T <sub>stg</sub>	-55 to +150	°C

\* PW ≤ 10 μs, duty cycle ≤ 1 %

\*\* Value at T<sub>c</sub> = 25 °C

\*\*\* Value at T<sub>ch</sub> = 25 °C, R<sub>g</sub> ≥ 50 Ω

**Table 2 Electrical Characteristics** (Ta = 25°C)

Item	Symbol	Min	Typ	Max	Unit	Test conditions
Drain to source breakdown voltage	$V_{(BR)DSS}$	60	—	—	V	$I_D = 10 \text{ mA}$ , $V_{GS} = 0$
Gate to source breakdown voltage	$V_{(BR)GSS}$	$\pm 20$	—	—	V	$I_G = \pm 100 \text{ }\mu\text{A}$ , $V_{DS} = 0$
Gate to source leak current	$I_{GSS}$	—	—	$\pm 10$	$\mu\text{A}$	$V_{GS} = \pm 16 \text{ V}$ , $V_{DS} = 0$
Zero gate voltage drain current	$I_{DSS}$	—	—	250	$\mu\text{A}$	$V_{DS} = 50 \text{ V}$ , $V_{GS} = 0$
Gate to source cutoff voltage	$V_{GS(off)}$	1.0	—	2.25	V	$I_D = 1 \text{ mA}$ , $V_{DS} = 10 \text{ V}$
Static drain to source on state resistance	$R_{DS(on)}$	—	0.10	0.13	$\Omega$	$I_D = 8 \text{ A}$ $V_{GS} = 10 \text{ V}^*$
		—	0.13	0.18	$\Omega$	$I_D = 8 \text{ A}$ $V_{GS} = 4 \text{ V}^*$
Forward transfer admittance	$ y_{fs} $	4.5	8	—	S	$I_D = 8 \text{ A}$ $V_{DS} = 10 \text{ V}^*$
Input capacitance	$C_{iss}$	—	390	—	pF	$V_{DS} = 10 \text{ V}$
Output capacitance	$C_{oss}$	—	190	—	pF	$V_{GS} = 0$
Reverse transfer capacitance	$C_{rss}$	—	45	—	pF	$f = 1 \text{ MHz}$
Turn-on delay time	$t_{d(on)}$	—	10	—	ns	$I_D = 8 \text{ A}$
Rise time	$t_r$	—	65	—	ns	$V_{GS} = 10 \text{ V}$
Turn-off delay time	$t_{d(off)}$	—	90	—	ns	$R_L = 3.75 \text{ }\Omega$
Fall time	$t_f$	—	90	—	ns	
Body-drain diode forward voltage	$V_{DF}$	—	1.3	—	V	$I_F = 15 \text{ A}$ , $V_{GS} = 0$
Body-drain diode reverse recovery time	$t_{rr}$	—	90	—	ns	$I_F = 15 \text{ A}$ , $V_{GS} = 0$ , $di_F / dt = 50 \text{ A} / \mu\text{s}$

\* Pulse Test

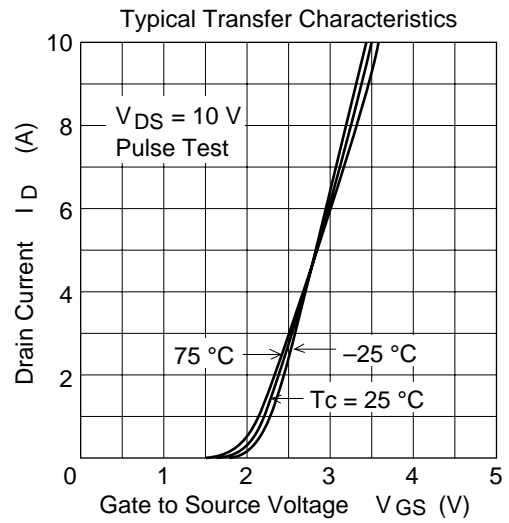
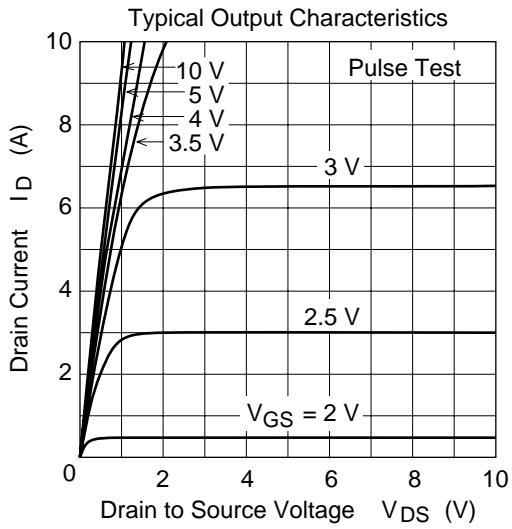
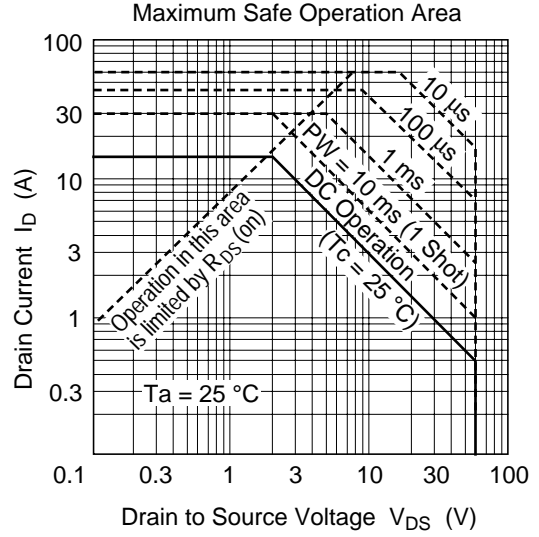
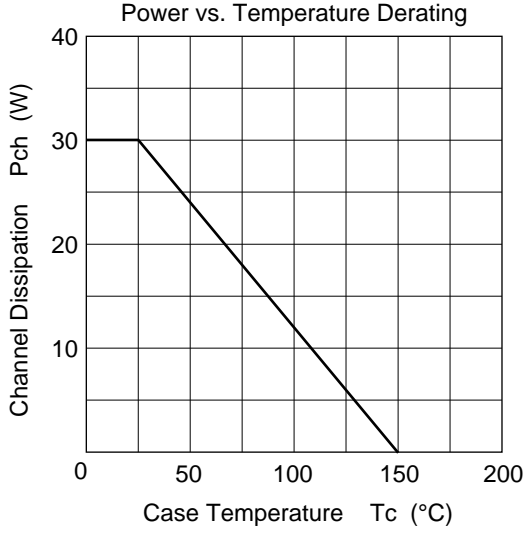

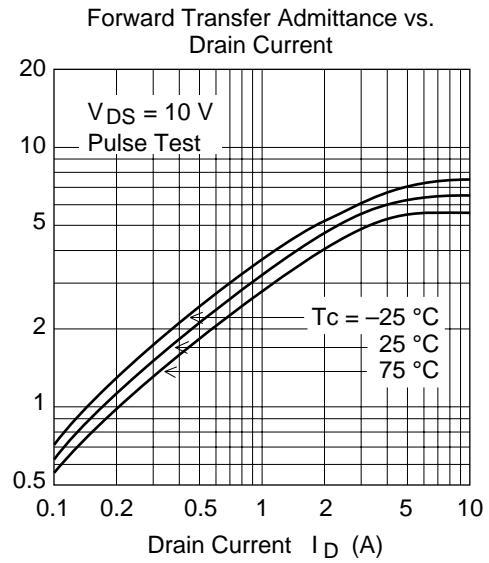
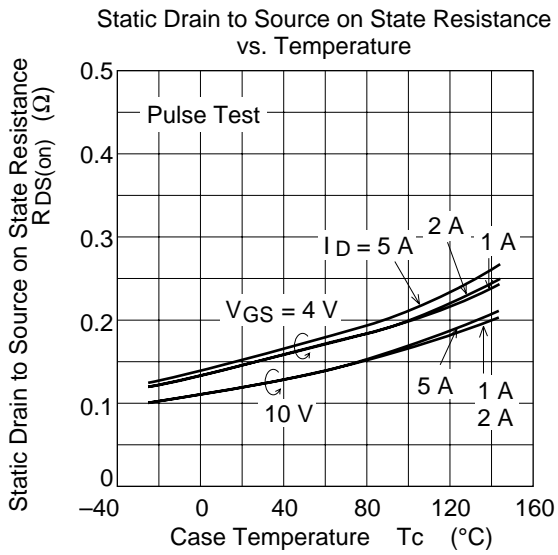
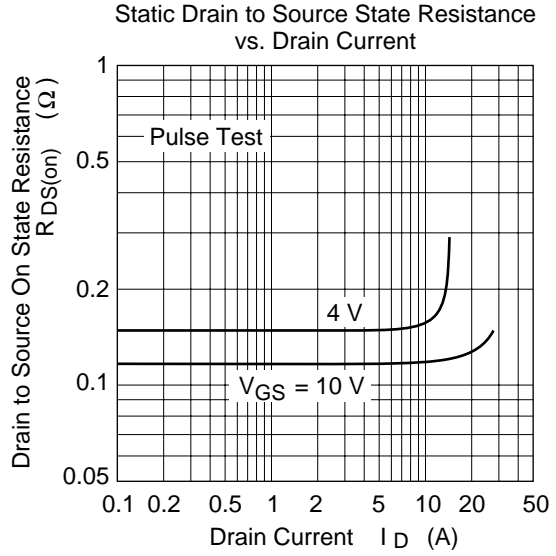
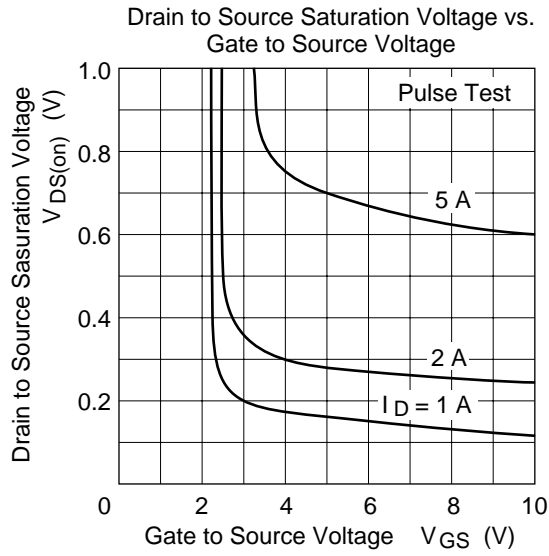

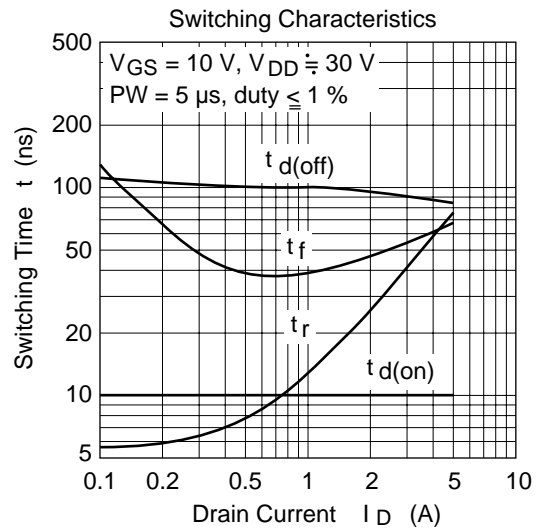
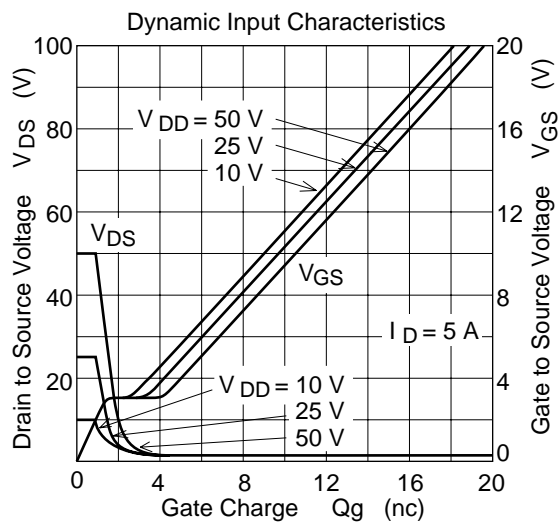
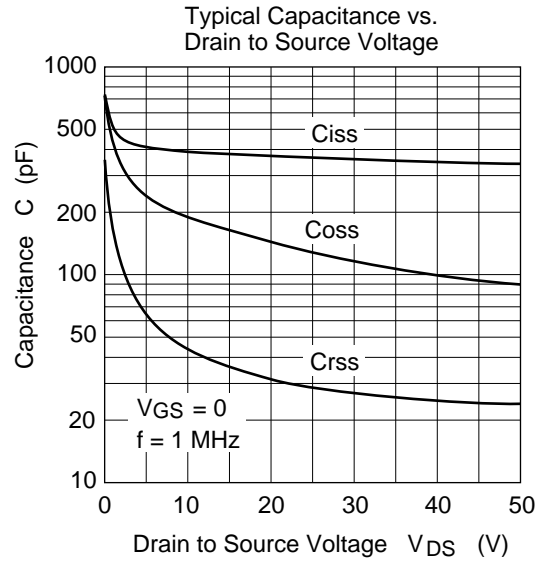
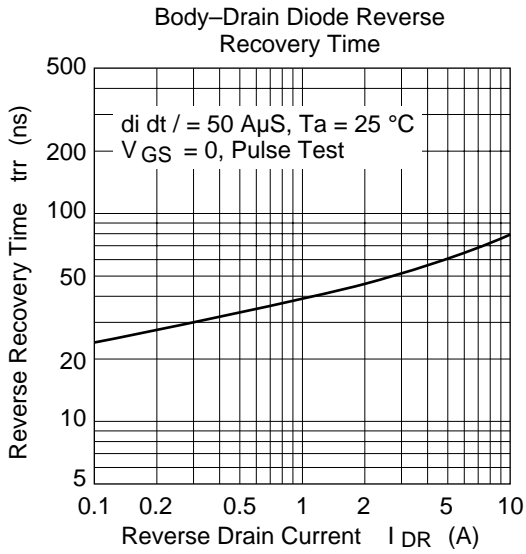

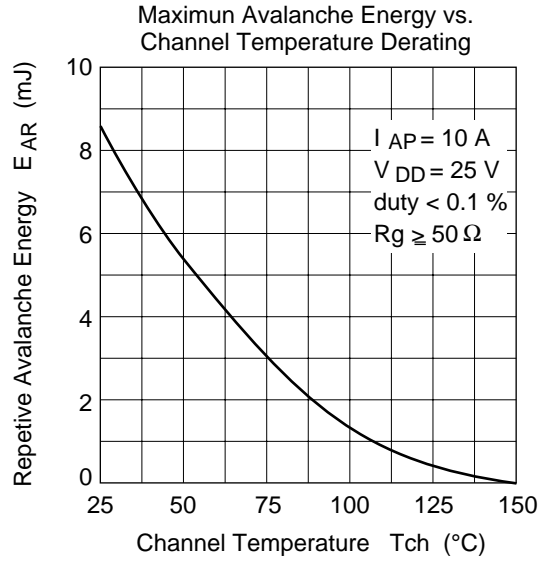
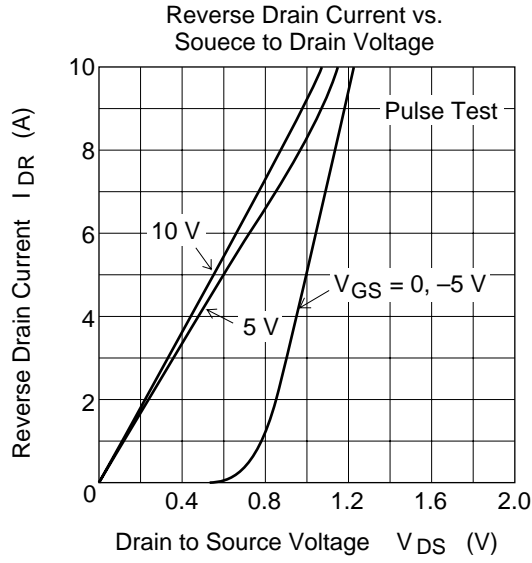

Avalanche Test Circuit and Waveform

