

SPECIFICATION

DEVICE NAME : Power MOSFET

TYPE NAME : 2SK2494-01

SPEC. No. : _____

Fuji Electric Co.,Ltd.

This Specification is subject to change without notice.

	DATE	NAME	APPROVED	Fuji Electric Co.,Ltd.	
DRAWN				DWG. NO.	1/11
CHECKED					

1. Scope
This specifies Fuji power MOSFET 2SK2494-01
2. Construction N-channel enhancement mode power MOSFET
3. Application for switching
4. Outview TO-220 Outview See to 5/11 page
5. Absolute maximum ratings at $T_c=25^\circ\text{C}$ (unless otherwise specified)

Description	Symbol	Characteristics	Unit	Remarks
Drain-source voltage	V_{DS}	60	V	
Drain-gate voltage	V_{DGR}	60	V	$R_{GS}=20\text{K}\Omega$
Continuous Drain current	I_D	± 45	A	
Pulsed drain current	I_{Dpulso}	± 200	A	
Gate-source voltage	V_{GS}	± 30	V	
Maximum power dissipation	P_D	80	W	
Operating and storage temperature range	T_{ch}	150	$^\circ\text{C}$	
	T_{sto}	-55 ~ +150	$^\circ\text{C}$	

6. Electrical characteristics at $T_c=25^\circ\text{C}$ (unless otherwise specified)

Description	Symbol	Conditions	Characteristics			Unit
			Min.	Typ.	Max.	
Drain-source breakdown voltage	BV_{DSS}	$I_D=1\text{mA}$ $V_{GS}=0\text{V}$	60			V
Gate threshold voltage	$V_{GS(th)}$	$I_D=10\text{mA}$ $V_{DS}=V_{GS}$	2.5	3.0	3.5	V
Zero gate voltage drain current	I_{DSS}	$V_{DS}=60\text{V}$ $V_{GS}=0\text{V}$		10	500	μA
	I_{DSS}	$T_{ch}=125^\circ\text{C}$		0.2	1.0	mA
Gate-source leakage current	I_{GSS}	$V_{GS}=\pm 30\text{V}$ $V_{DS}=0\text{V}$		10	100	nA
Drain-source on-state resistance	$R_{DS(on)}$	$I_D=25\text{A}$ $V_{GS}=10\text{V}$		17	25	$\text{m}\Omega$

Fuji Electric Co., Ltd.

DWG. NO.

2/11

Y 0257-R-003a

Dynamic ratings

Description	Symbol	Conditions	Characteristics			Unit
			Min.	Typ.	Max.	
Forward transconductance	g f s	$I_D = 25 \text{ A}$ $V_{DS} = 25 \text{ V}$	11	22		S
Input capacitance	Ciss	$V_{DS} = 25 \text{ V}$ $V_{GS} = 0 \text{ V}$ $f = 1 \text{ MHz}$		2000	3000	pF
Output capacitance	Coss			800	1200	pF
Reverse transfer capacitance	Crss			300	450	pF
Turn-on time	t d(on)	$V_{CC} = 30 \text{ V}$ $V_{GS} = 10 \text{ V}$ $I_D = 45 \text{ A}$ $R_{CS} = 25 \Omega$		25	40	ns
	t r			150	230	ns
Turn-off time	t d(off)			140	210	ns
	t f			125	190	ns

Reverse diode

Description	Symbol	Conditions	Characteristics			Unit
			Min.	Typ.	Max.	
Avalanche capability	I_{AV}	$L = 100 \mu\text{H}$, $T_{ch} = 25^\circ\text{C}$ * see Fig1 and 2	45			A
Diode forward on-voltage	V_{SD}	$I_F = 2 \times I_{DR}$ $V_{GS} = 0 \text{ V}$, $T_{ch} = 25^\circ\text{C}$		1.3	1.95	V
Reverse recovery time	t_{rr}	$I_F = I_{DR}$ $V_{GS} = 0 \text{ V}$ $-di_F/dt = 100 \text{ A}/\mu\text{s}$ $T_{ch} = 25^\circ\text{C}$		60		ns
Reverse recovery charge	Q_{rr}				0.12	

7. Thermal resistance

Description	Symbol	Conditions	Characteristics			Unit
			Min.	Typ.	Max.	
Thermal resistance	$R_{th_{ch-C}}$				1.56	$^\circ\text{C}/\text{W}$
	$R_{th_{ch-a}}$				75.0	$^\circ\text{C}/\text{W}$

Fig.1 Test circuit

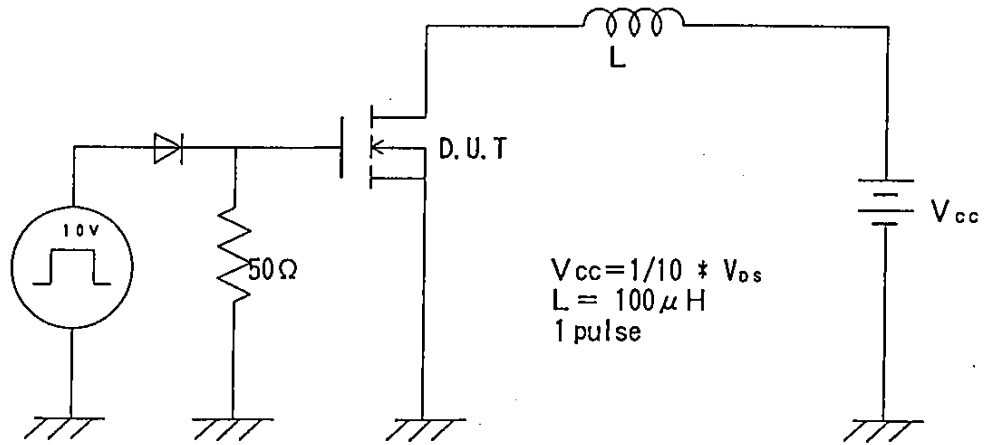
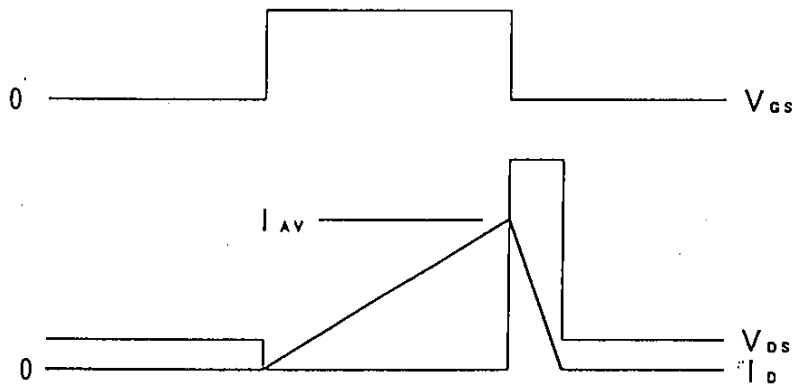
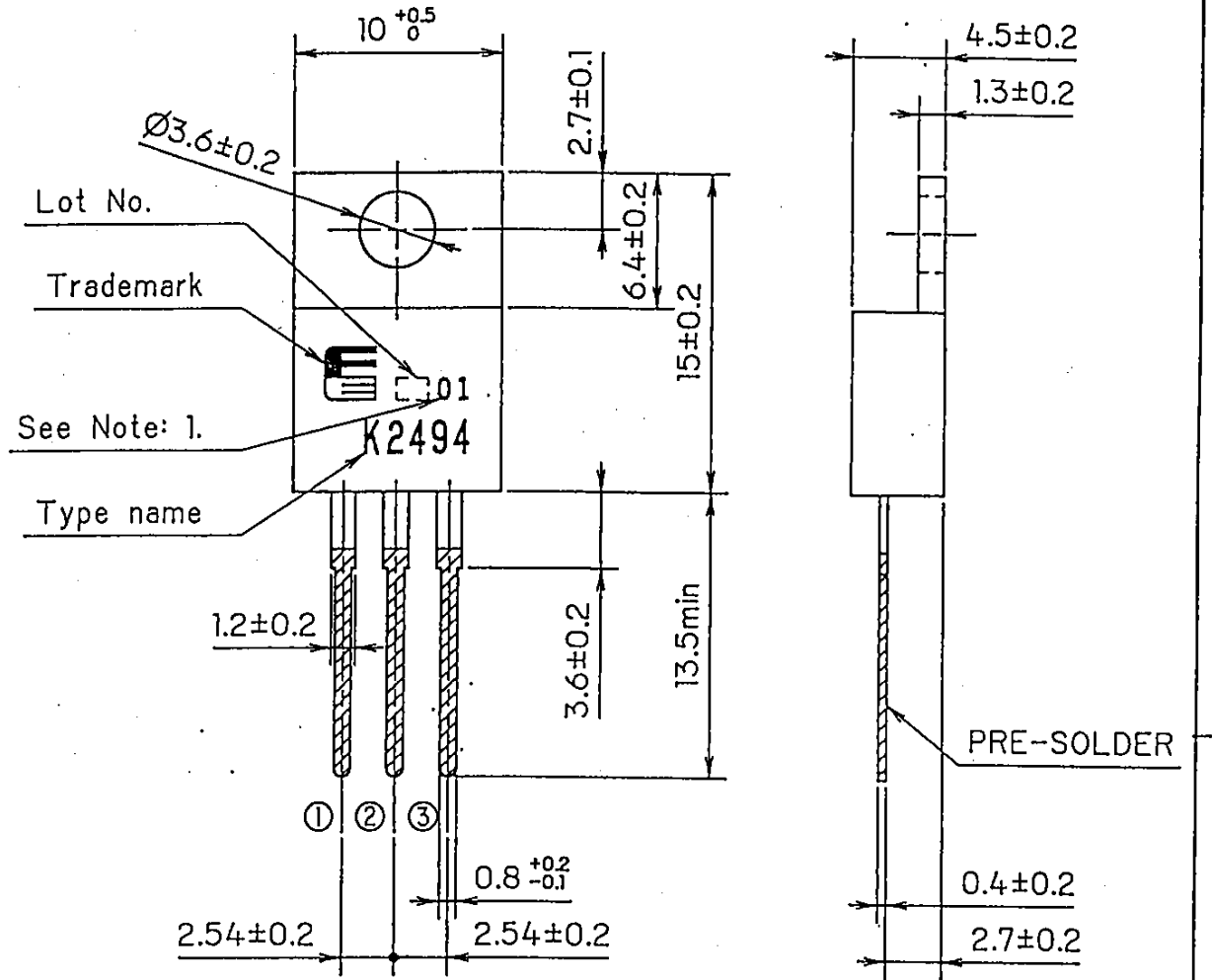

Fig.2 Operating waveforms



FUJI POWER MOS FET

TYPE : 2SK2494-01



CONNECTION

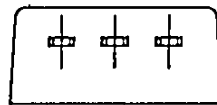

① ② ③

- ① GATE
- ② DRAIN
- ③ SOURCE

JEDEC : TO-220AB

Note: 1. Guaranteed mark of avalanche ruggedness.

DIMENSIONS ARE IN MILLIMETERS.

Fuji Electric Co., Ltd.

DWG. NO.

5/11

Y 0257-R-003a

Power Dissipation
 $PD=f(T_c)$

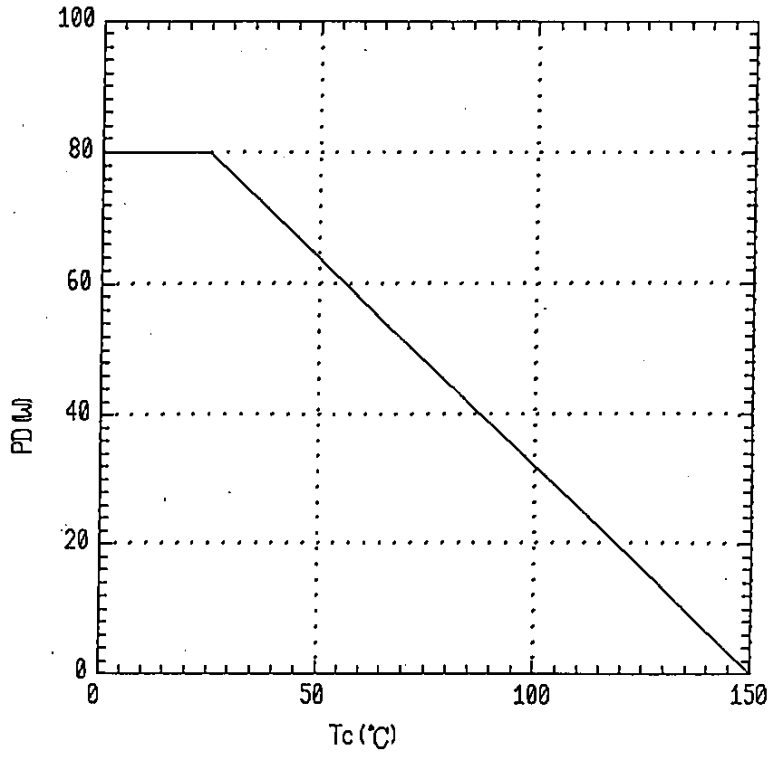

Safe operating area
 $ID=f(V_{DS}): D=0.01, T_c=25^\circ C$

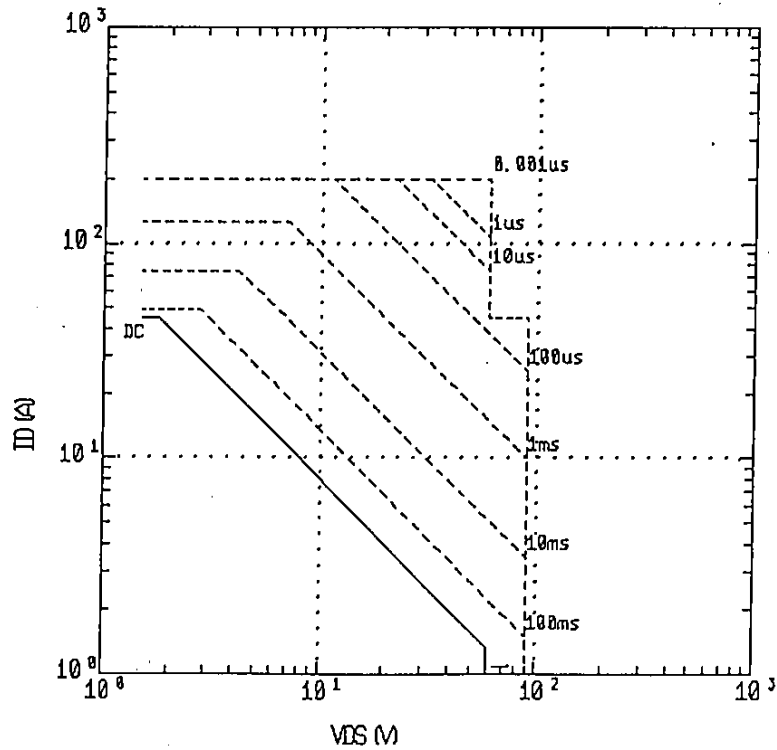

Fuji Electric Co., Ltd.

DWG. NO.

6/11

Typical output characteristics
 $I_D = f(V_{DS})$: 80 μ s pulse test, $T_{ch} = 25^\circ\text{C}$

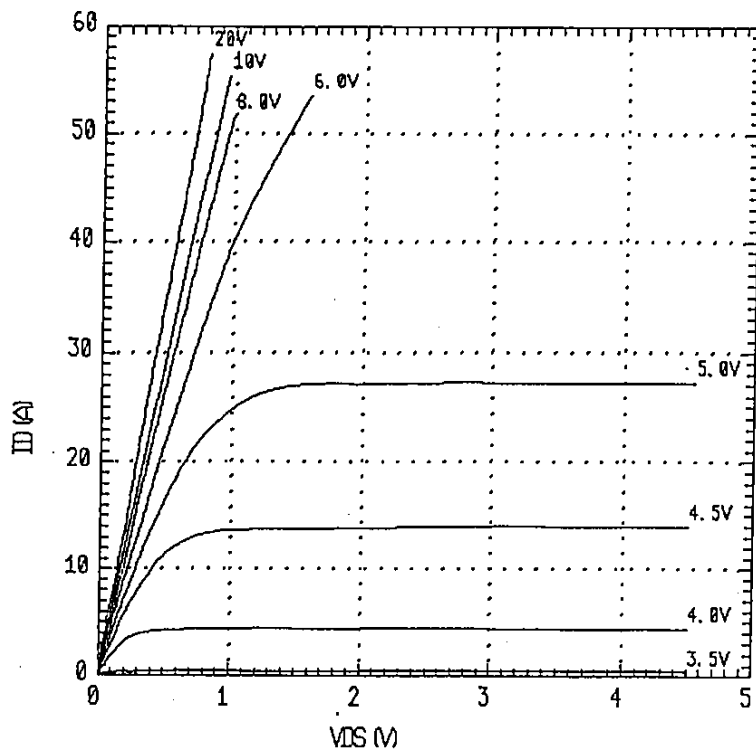

Typical Transfer Characteristics
 $I_D = f(V_{GS})$: 80 μ s pulse test, $V_{DS} = 25\text{V}$, $T_{ch} = 25^\circ\text{C}$

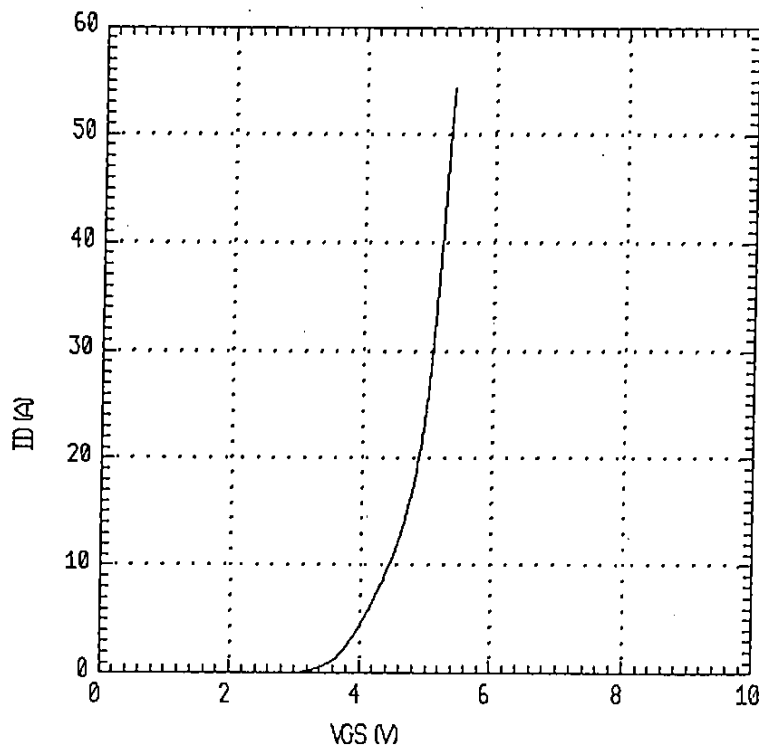

Typical Transconductance
 $g_{fs} = f(I_D)$: $80 \mu s$ pulse test, $V_{DS} = 25V$, $T_{ch} = 25^\circ C$

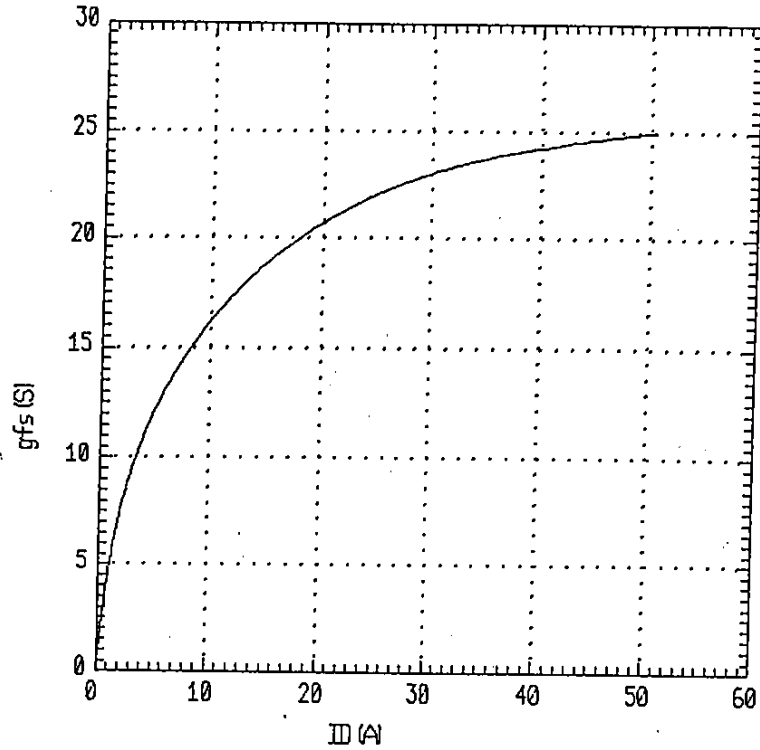

Typical Drain-source on-state resistance
 $R_{DS(on)} = f(I_D)$: $80 \mu s$ pulse test, $T_{ch} = 25^\circ C$

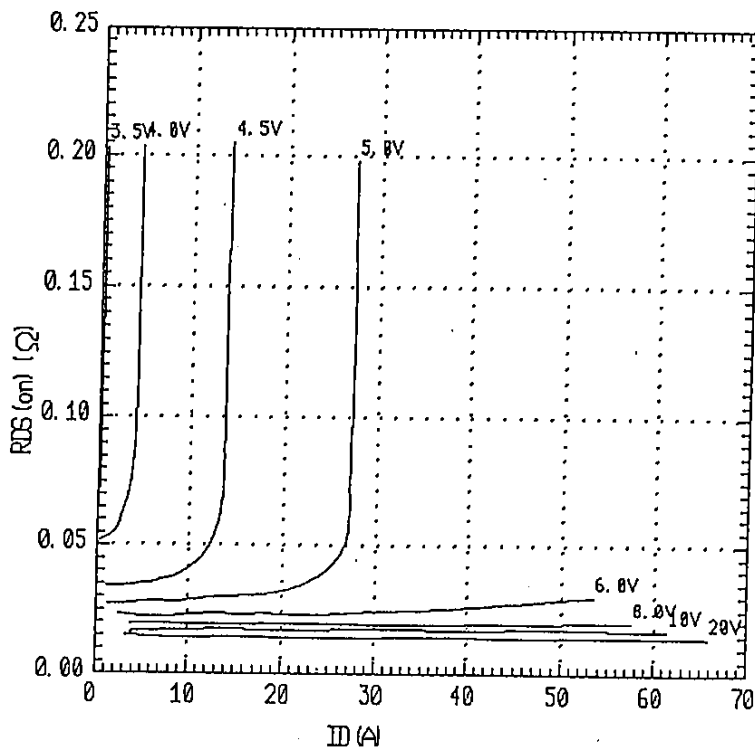

Drain-source on-state resistance
 $R_{DS(on)} = f(T_{ch}) : I_D = 25A, V_{GS} = 10V$

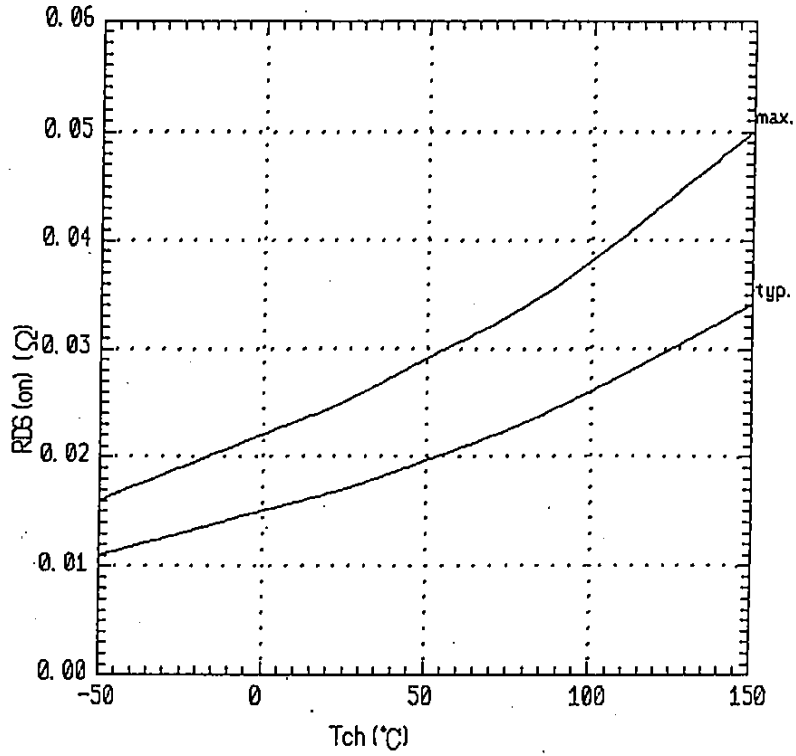

Gate threshold voltage
 $V_{GS(th)} = f(T_{ch}) : V_{DS} = V_{GS}, I_D = 10mA$

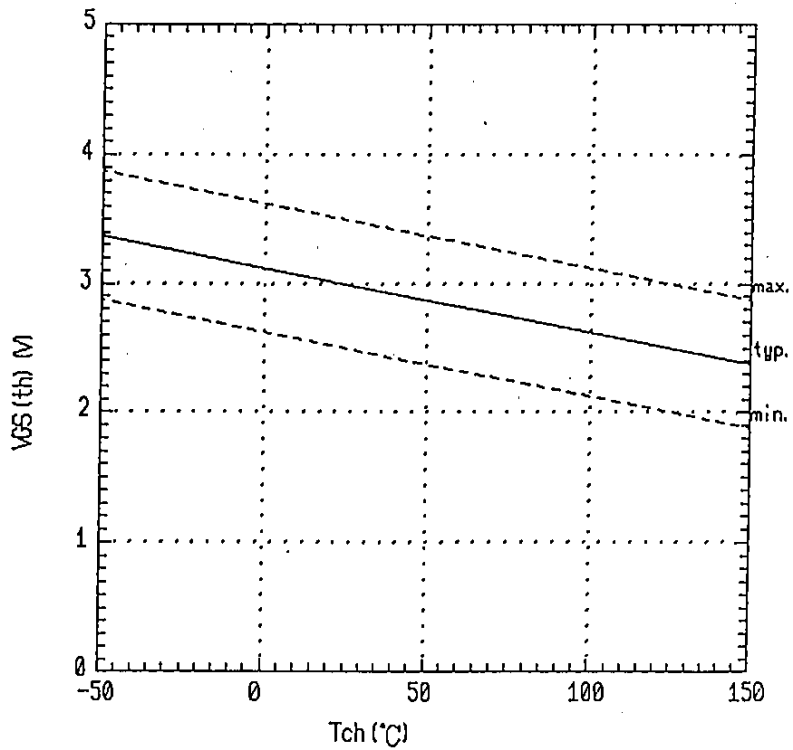

Fuji Electric Co., Ltd.

DWG. NO.

9/11

Y 0257-R-003a

Typical gate charge characteristics
 $V_{GS} = f(Q_g) : I_D = 45A$

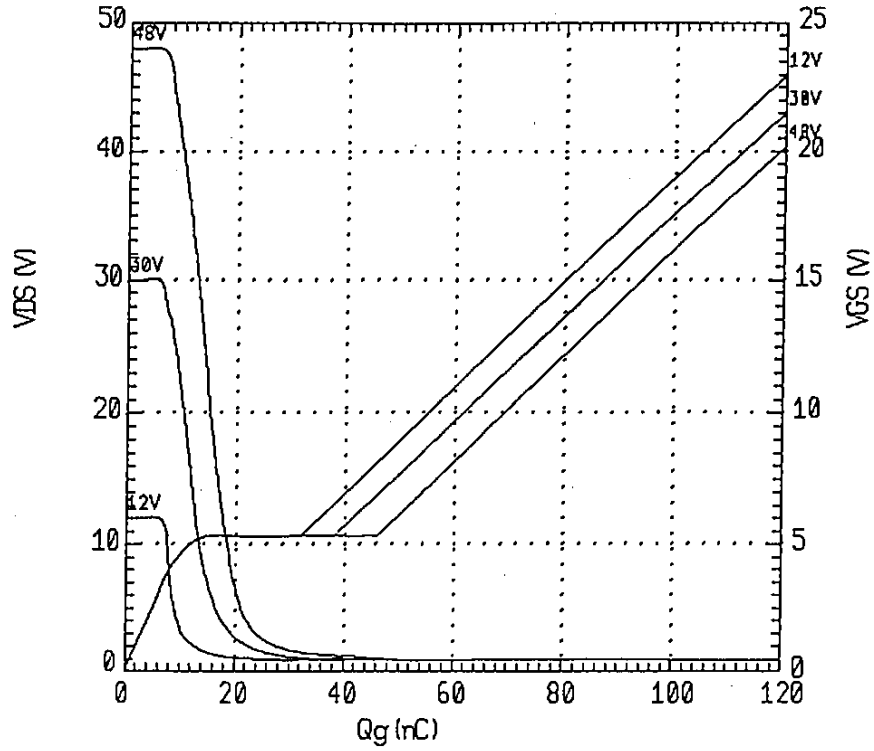

Typical capacitances
 $C = f(V_{DS}) : V_{GS} = 0V, f = 1MHz$

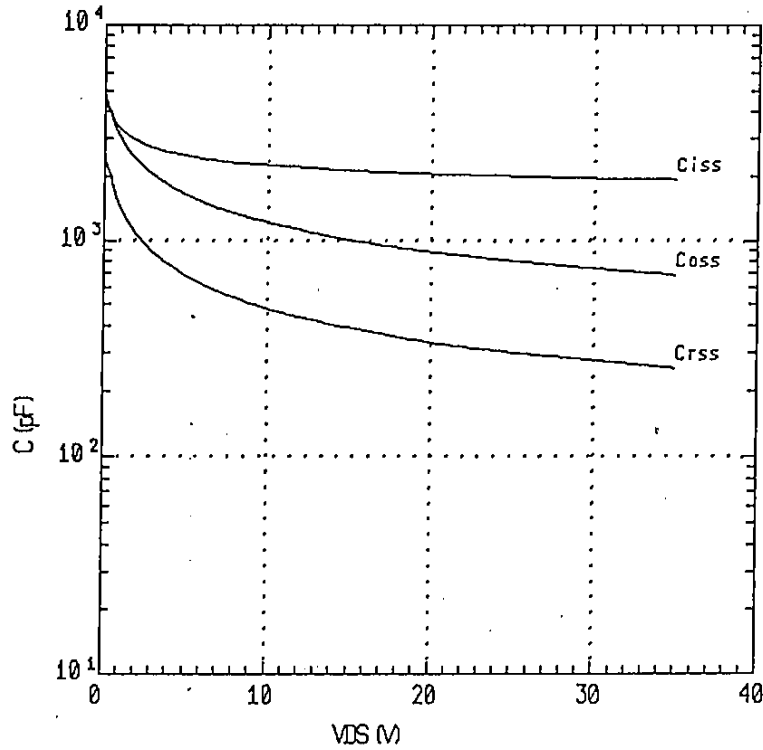

Fuji Electric Co., Ltd.

DWG. NO.

10/11

Y 0257-R-003a

Forward characteristic of reverse diode
 $I_F = f(V_{SD}) : 80 \mu s$ pulse test

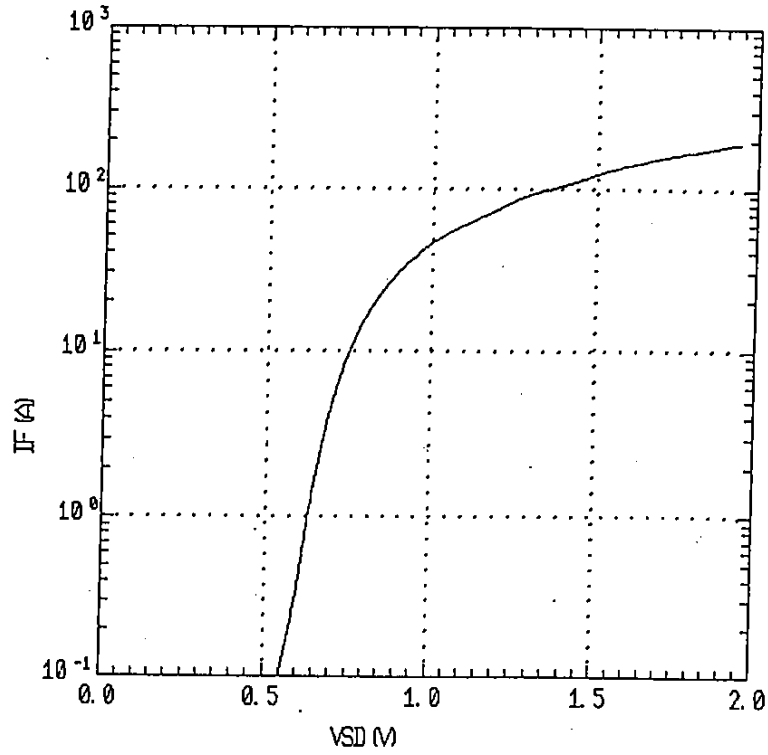

Transient thermal impedance $Z_{thch-c} = f(t)$ parameter: $D = t/T$

