

SPECIFICATION

DEVICE NAME : Power MOSFET

TYPE NAME : 2SK2687-01

SPEC. NO. :

Fuji Electric Co.,Ltd.

This Specification is subject to change without notice.

	DATE	NAME	APPROVED	Fuji Electric Co.,Ltd.	
DRAWN				DWG. NO.	1/13
CHECKED					

- 1.Scope This specifies Fuji Power MOSFET 2SK2687-01
- 2.Construction N-Channel enhancement mode power MOSFET
- 3.Applications for Switching
- 4.Outview TO-220 Outview See to 5/13 page

5.Absolute Maximum Ratings at Tc=25°C (unless otherwise specified)

Description	Symbol	Characteristics	Unit	Remarks
Drain-Source Voltage	V _{DS}	30	V	
Continuous Drain Current	I _D	±50	A	
Pulsed Drain Current	I _{DP}	±200	A	
Gate-Source Voltage	V _{GS}	±16	V	
Maximum Avalanche Energy	E _{AV}	520	mJ	*1
Maximum Power Dissipation	P _D	60	W	
Operating and Storage	T _{ch}	150	°C	
Temperature range	T _{stg}	-55 to +150	°C	

*1 L=0.277mH, V_{CC}=12V

6.Electrical Characteristics at Tc=25°C (unless otherwise specified)

Static Ratings

Description	Symbol	Conditions	min.	typ.	max.	Unit
Drain-Source Breakdown Voltage	BV _{DSS}	I _D =1mA V _{GS} =0V	30			V
Gate Threshold Voltage	V _{GS(th)}	I _D =1mA V _{DS} =V _{GS}	1.0	1.5	2.0	V
Zero Gate Voltage Drain Current	I _{DSS}	V _{DS} =30V V _{GS} =0V		10	500	μA
		T _{ch} =25°C				
		T _{ch} =125°C		0.2	1.0	mA
Gate-Source Leakage Current	I _{GSS}	V _{GS} =16V V _{DS} =0V		10	100	nA
Drain-Source On-State Resistance	R _{DS(on)}	I _D =25A		12	17	mΩ
		V _{GS} =4V				
		V _{GS} =10V		7.5	10	mΩ

Dynamic Ratings

Description	Symbol	Conditions	min.	typ.	max.	Unit
Forward Transconductance	g_{fs}	$I_D=25A$ $V_{DS}=25V$	22	45		S
Input Capacitance	C_{iss}	$V_{DS}=25V$		2750	4130	pF
Output Capacitance	C_{oss}	$V_{GS}=0V$		1300	1950	
Reverse Transfer Capacitance	C_{rss}	$f=1MHz$		600	900	
Turn-On Time	$t_{d(on)}$	$V_{ce}=15V$		13	20	ns
	t_r	$V_{GS}=10V$		55	83	
Turn-Off Time	$t_{d(off)}$	$I_D=50A$		180	270	
	t_f	$R_{GS}=10\Omega$		150	230	

Reverse Diode

Description	Symbol	Conditions	min.	typ.	max.	Unit
Avalanche Capability	I_{AV}	$L=100\mu H$ $T_{ch}=25^\circ C$ See Fig.1 and Fig.2	50			A
Diode Forward On-Voltage	V_{SD}	$I_F=2 \times I_{DR}$ $V_{GS}=0V$ $T_{ch}=25^\circ C$		1.14	1.71	V
Reverse Recovery Time	t_{rr}	$I_F=2 \times I_{DR}$		85	130	ns
Reverse Recovery Charge	Q_{rr}	$-di/dt=100A/\mu s$ $T_{ch}=25^\circ C$		0.17		μC

7.Thermal Resistance

Description	Symbol	min.	typ.	max.	Unit
Channel to Case	$R_{th(ch-c)}$			2.08	$^\circ C/W$
Channel to Ambient	$R_{th(ch-a)}$			75.0	$^\circ C/W$

Fig.1 Test Circuit

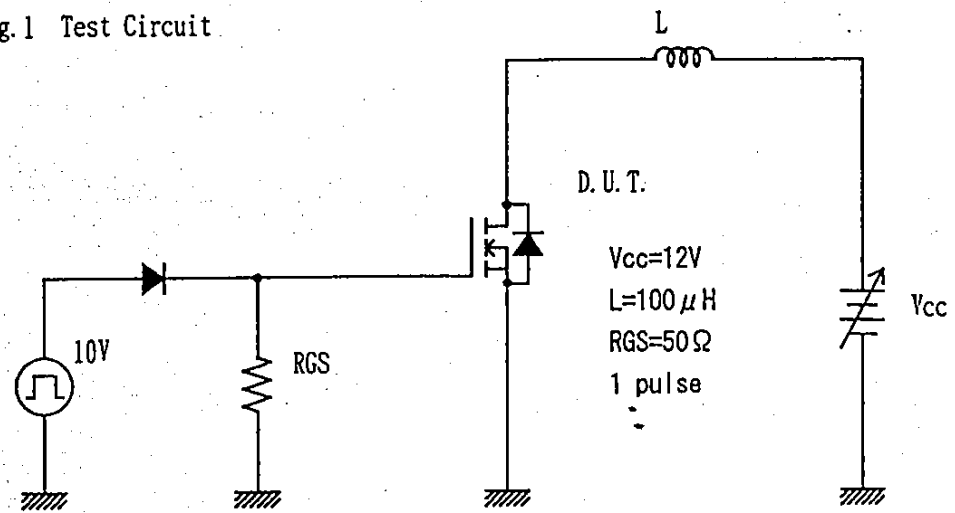
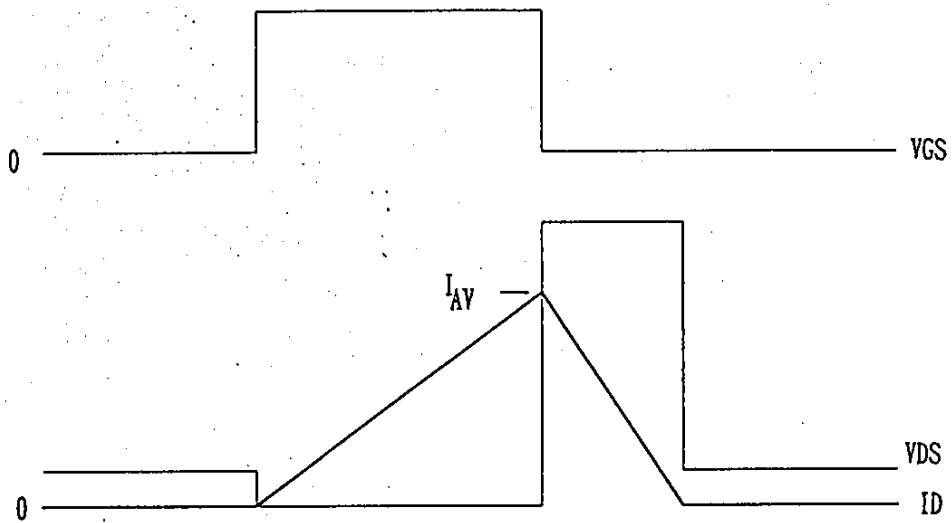
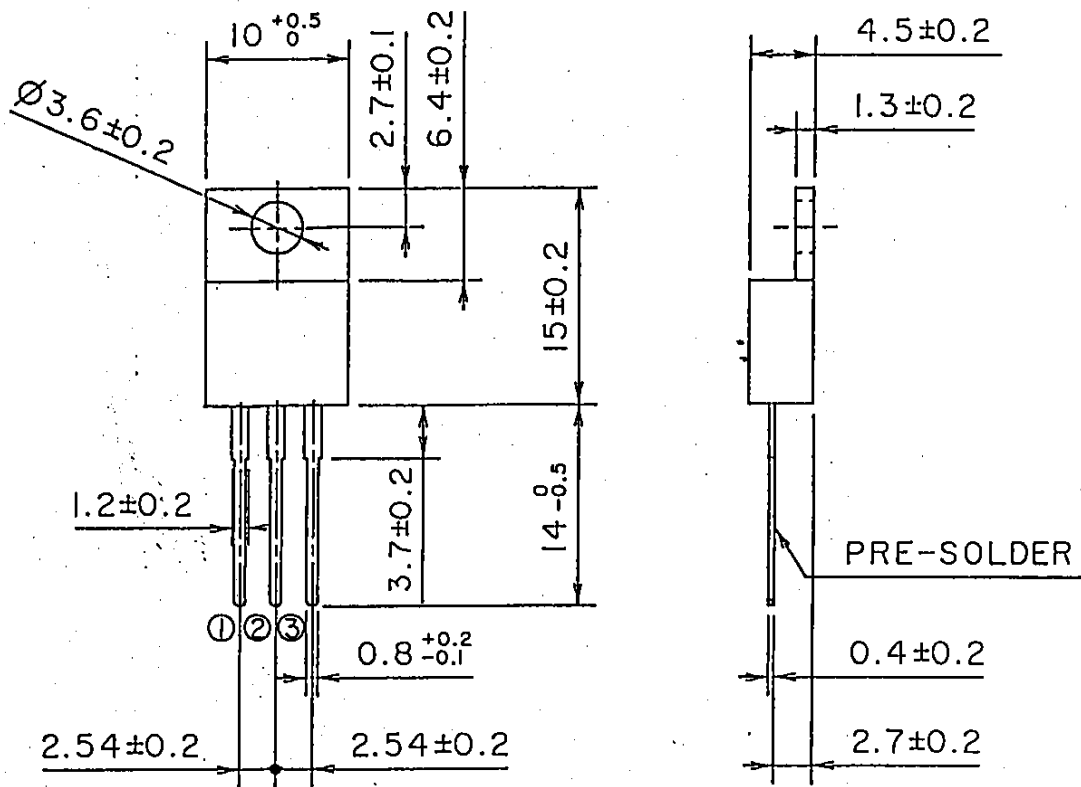

Fig.2 Operating waveforms





DIMENSIONS ARE IN MILLIMETERS.

CONNECTION

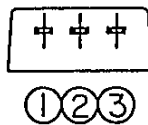

- ① GATE
- ② DRAIN
- ③ SOURCE

JEDEC : TO-220AB

Power Dissipation
 $PD=f(T_c)$

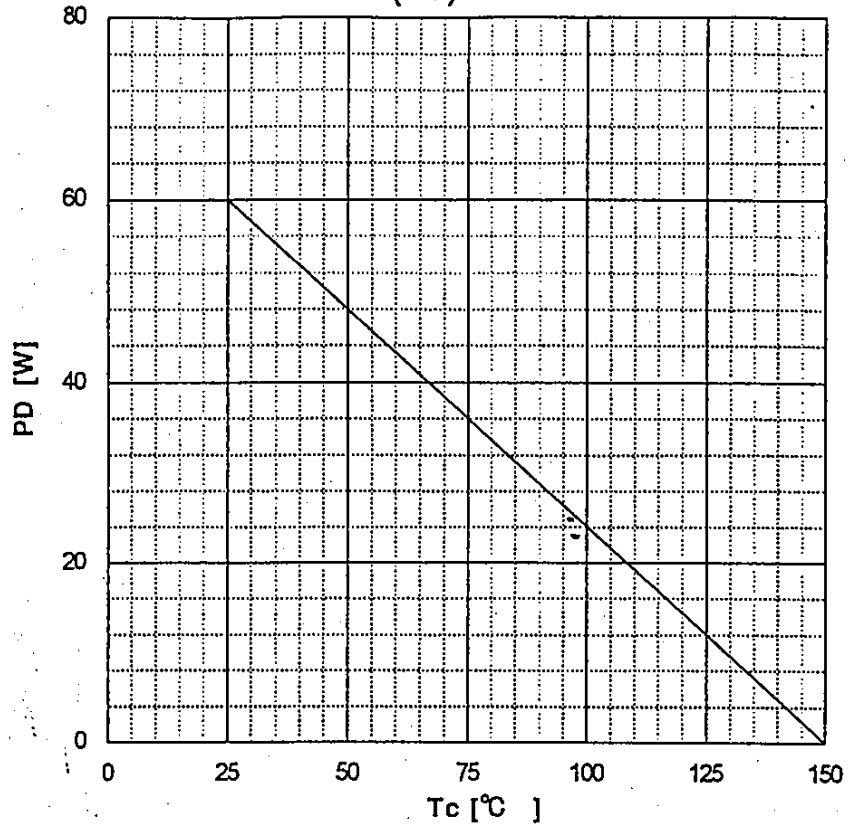

Safe operating area
 $ID=f(V_{DS}):D=0.01, T_c=25^\circ C$

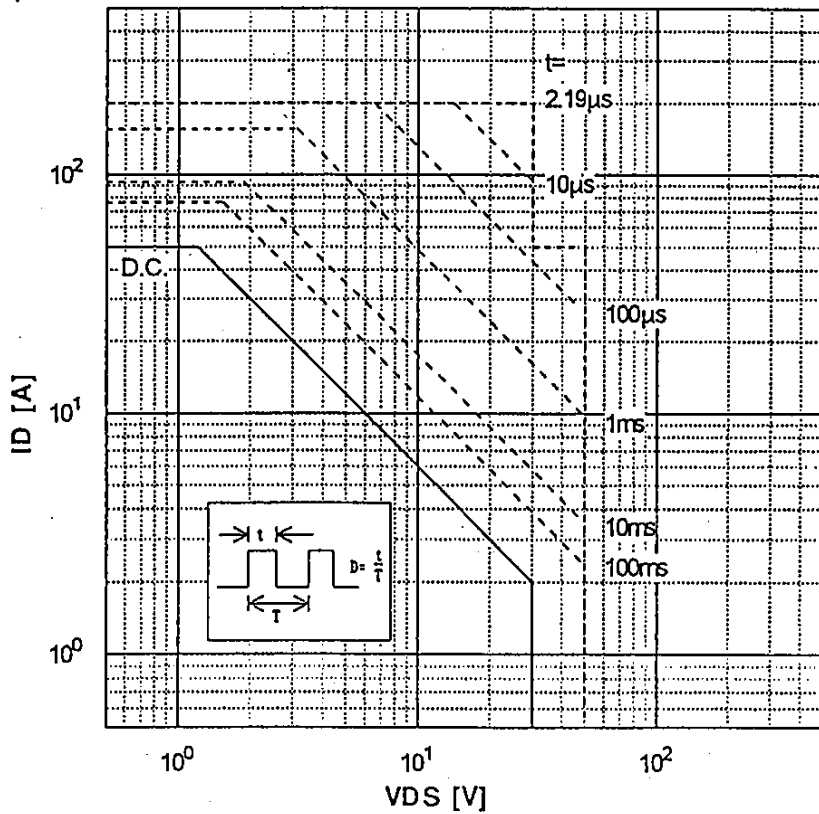

Typical Output Characteristics

$I_D = f(V_{DS})$: 80 μ s pulse test, $T_{ch} = 25^\circ\text{C}$

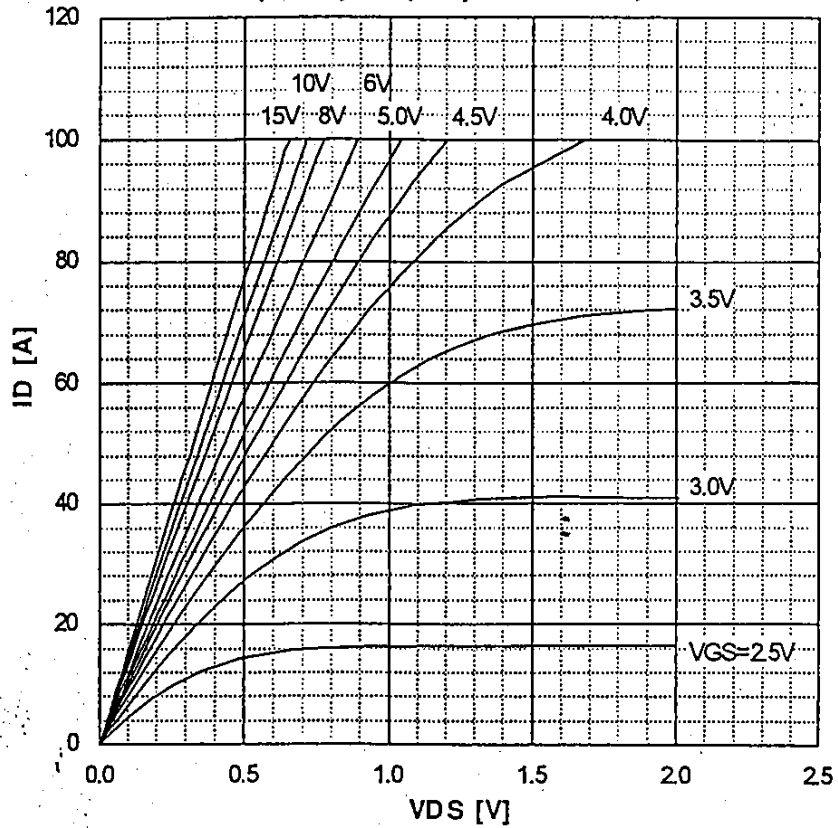

Typical Transfer Characteristic

$I_D = f(V_{GS})$: 80 μ s pulse test, $V_{DS} = 25V$, $T_{ch} = 25^\circ\text{C}$

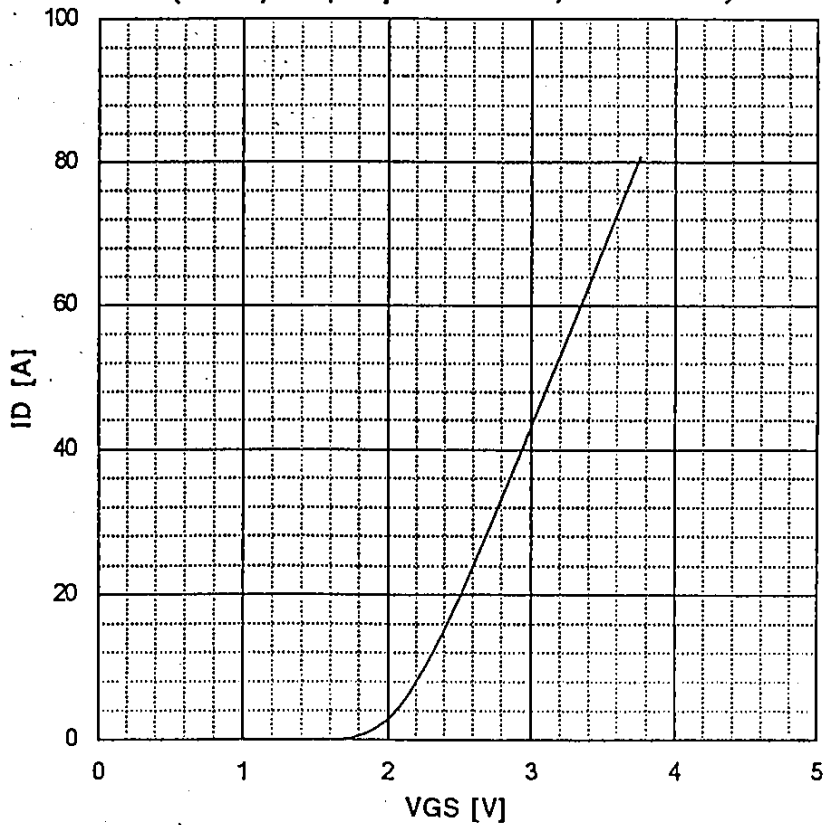

Typical Transconductance

$g_{fs}=f(I_D)$: 80 μ s pulse test, $V_{DS}=25V$, $T_{ch}=25^\circ C$

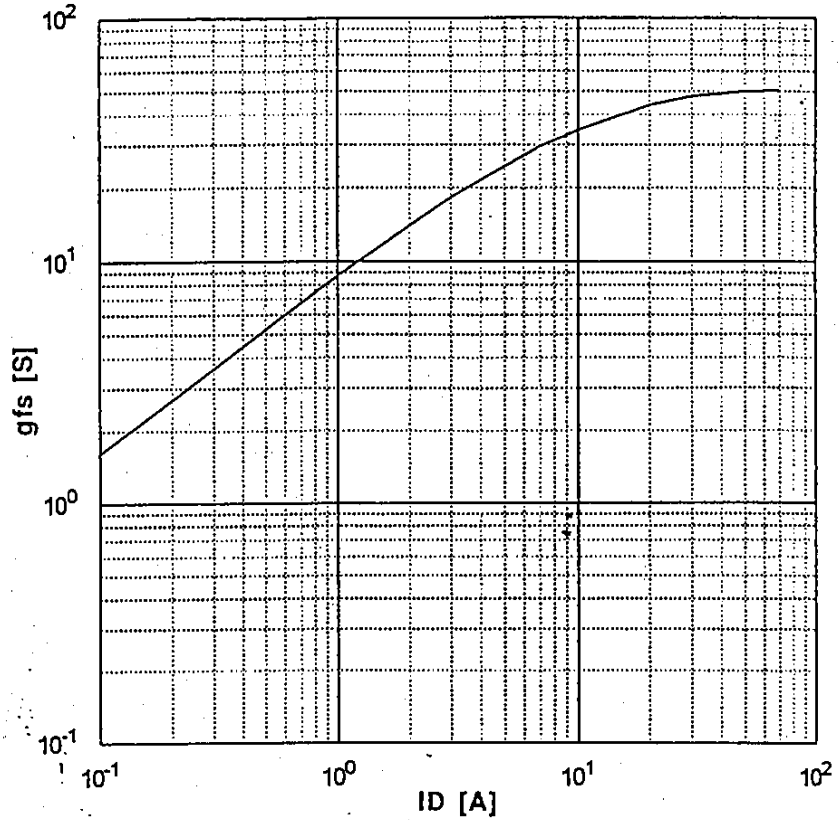

Typical Drain-Source on-state Resistance

$R_{DS(on)}=f(I_D)$: 80 μ s pulse test, $T_{ch}=25^\circ C$

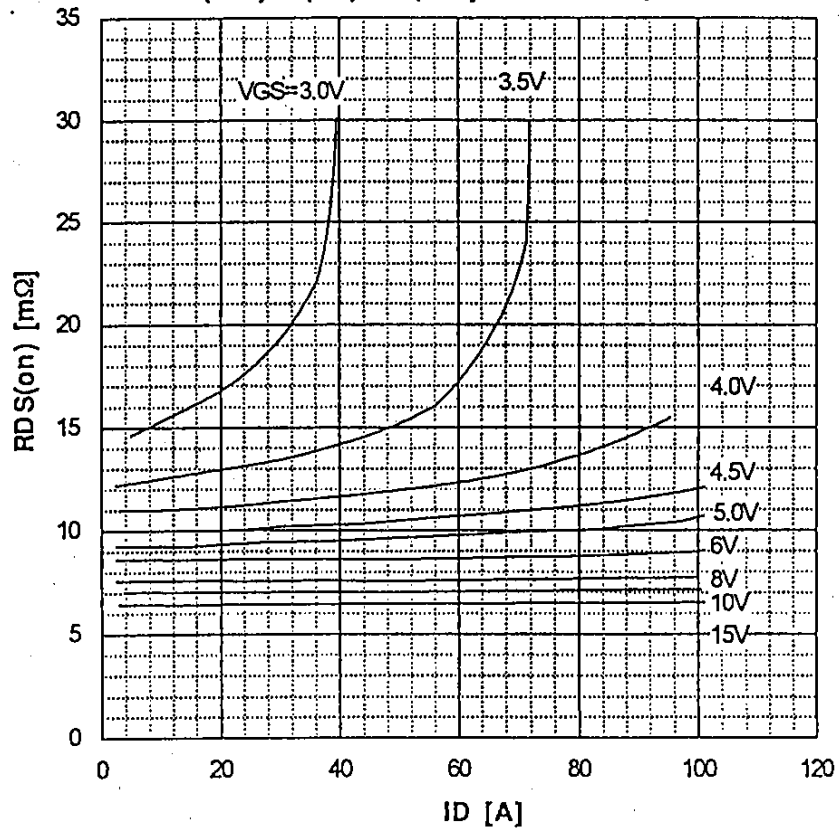

Drain-Source On-state Resistance
 $R_{DS(on)} = f(T_{ch}): I_D = 25A, V_{GS} = 10V$

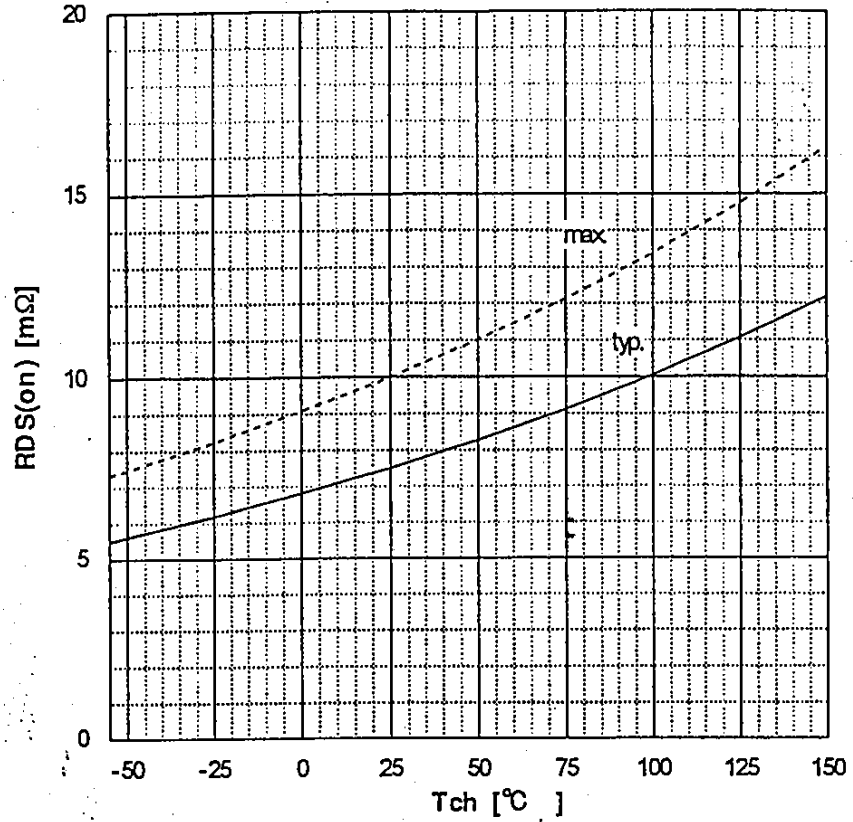

Gate Threshold Voltage
 $V_{GS(th)} = f(T_{ch}): V_{DS} = V_{GS}, I_D = 1mA$

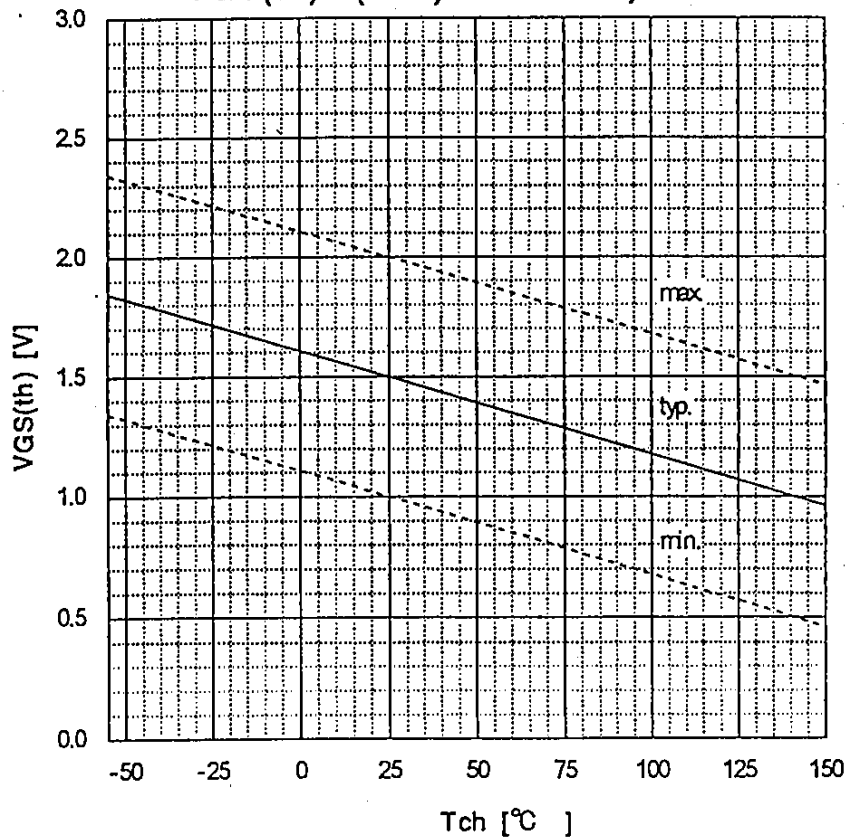

Typical Capacitance

$C=f(V_{DS}):V_{GS}=0V, f=1MHz$

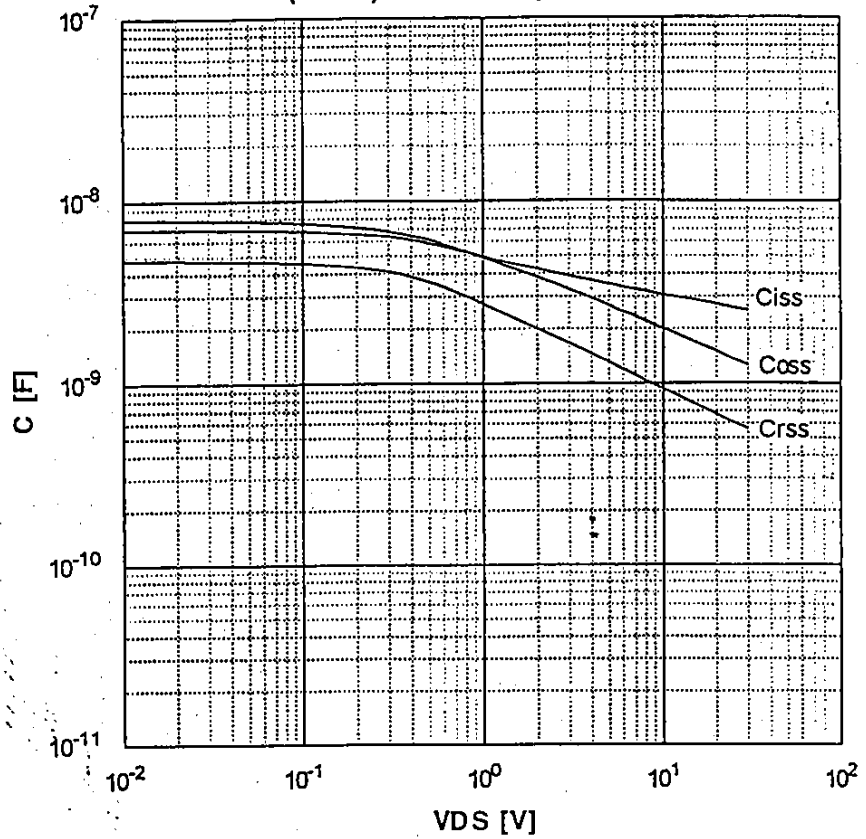

Typical Gate Charge Characteristics

$V_{GS}=f(Q_g):I_D=50A, T_{ch}=25^\circ C$

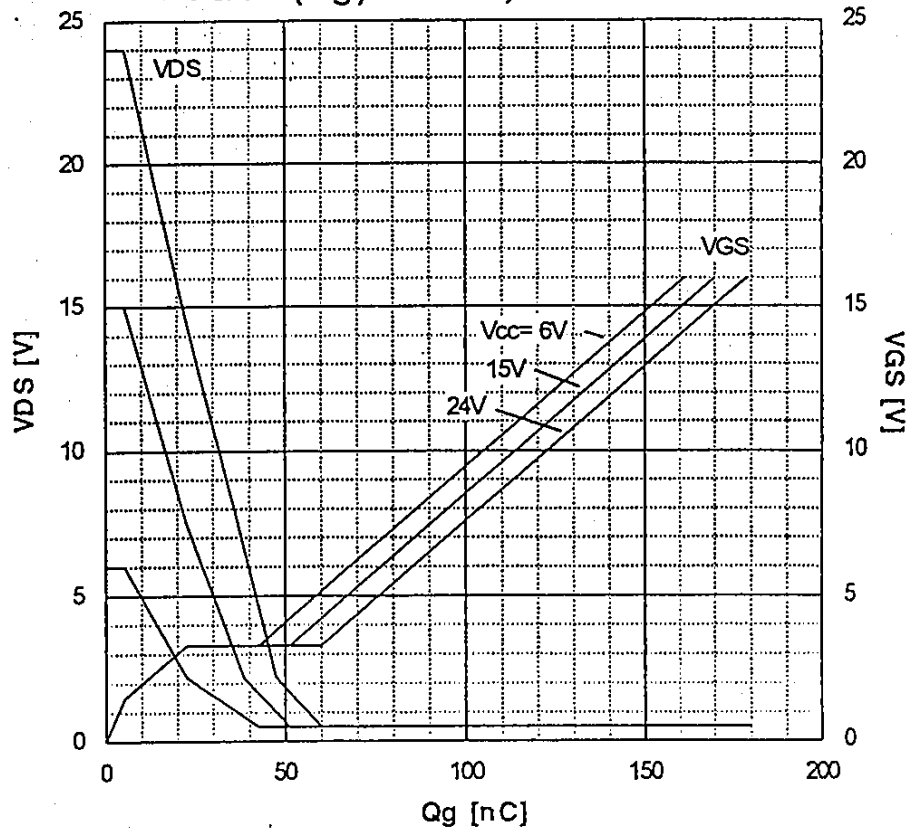

Typical Forward Characteristics of Reverse Diode
 $I_F = f(V_{SD})$: $80\mu\text{s}$ pulse test, $T_{ch} = 25^\circ\text{C}$

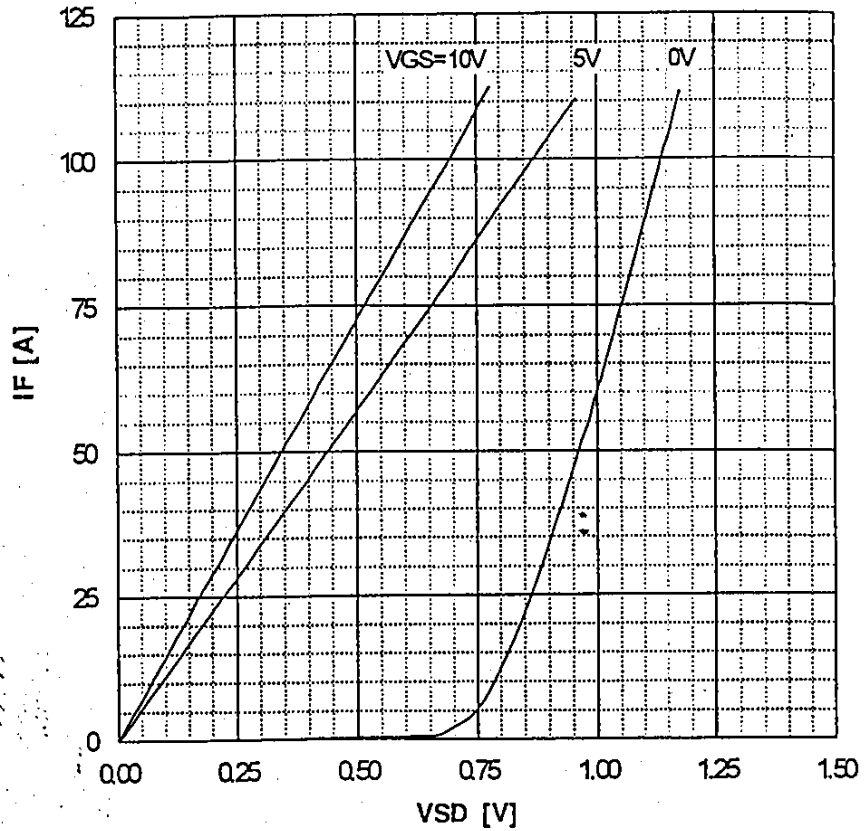

Typical Switching Characteristics vs. I_D
 $t = f(I_D)$: $V_{CC} = 15V$, $V_{GS} = 10V$, $R_G = 10\Omega$

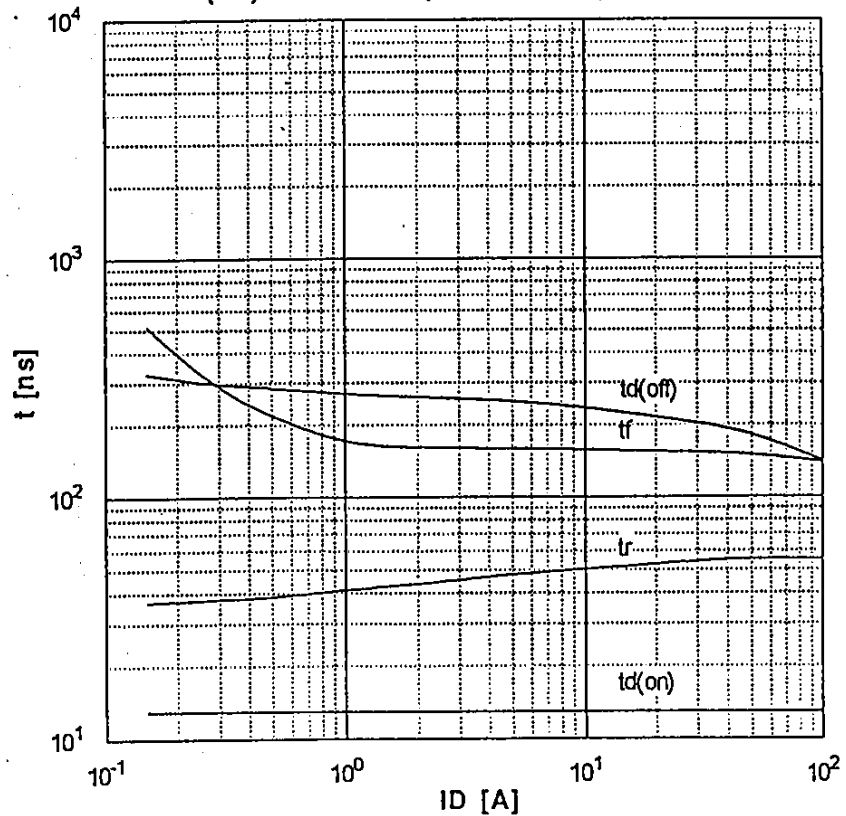

Maximum Avalanche Current vs. starting Tch
 $I(AV)=f(\text{starting Tch})$

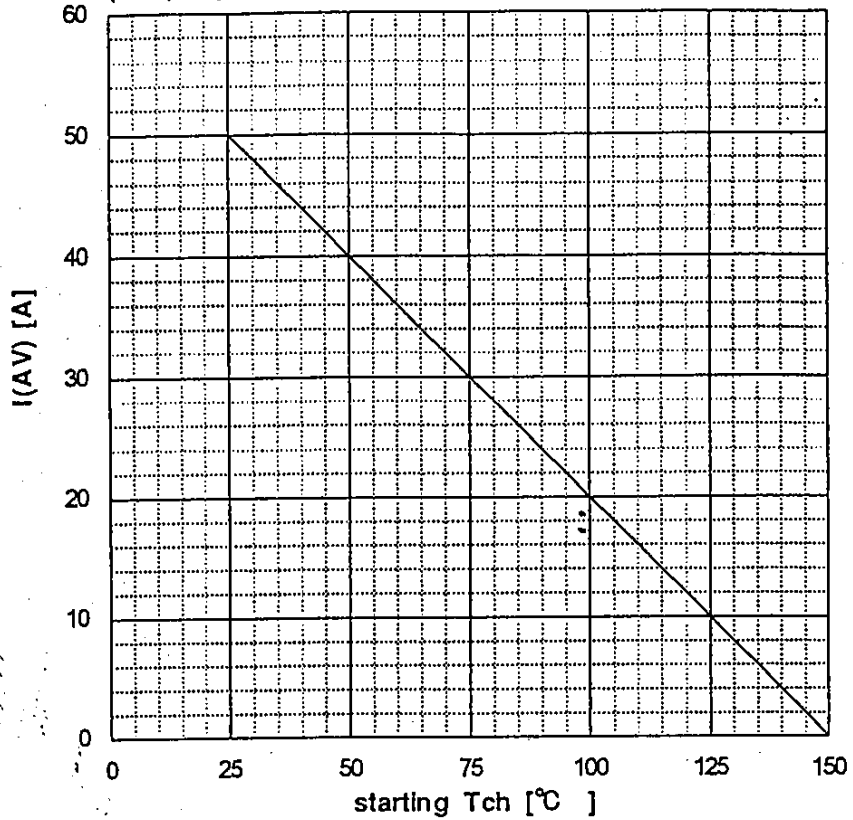

Maximum Avalanche Energy vs. starting Tch
 $E(AV)=f(\text{starting Tch}): V_{CC}=12V, I(AV) \leq 50A$

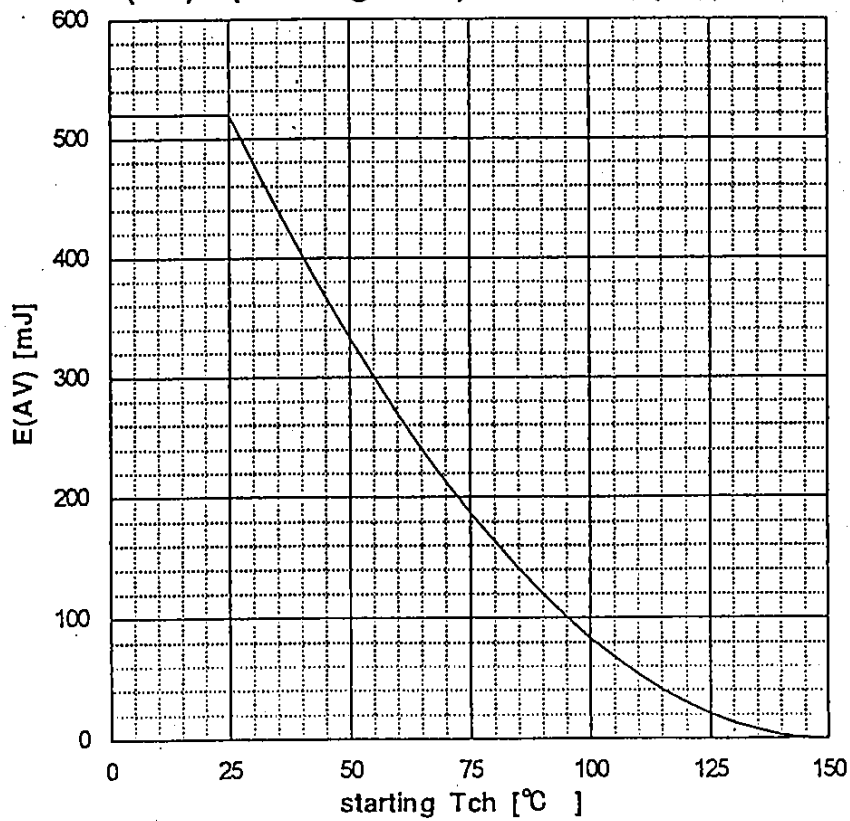

Transient Thermal impedance
 $Z_{th}(ch-c)=f(t)$ parameter: $D=t/T$

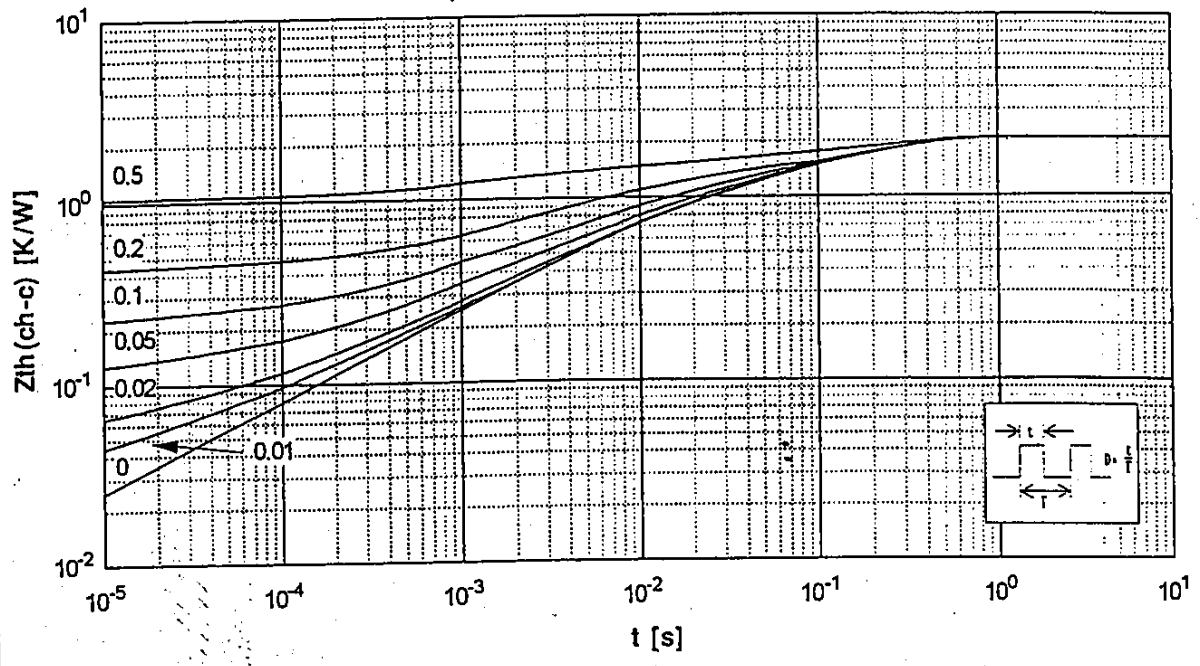

Fuji Electric Co.,Ltd.

DWG. NO.

13/13