

2SK416(L), 2SK416(S)

SILICON N-CHANNEL MOS FET

HITACHI/OPTOELECTRONIC

**HIGH SPEED POWER SWITCHING,
HIGH FREQUENCY POWER AMPLIFIER**
Complementary pair with 2SJ120

■ FEATURES

- Low On-Resistance.
- High Speed Switching.
- High Cutoff Frequency.
- No Secondary Breakdown.
- Suitable for Switching Regulator, DC-DC Converter, and Bubble Memory Driver.

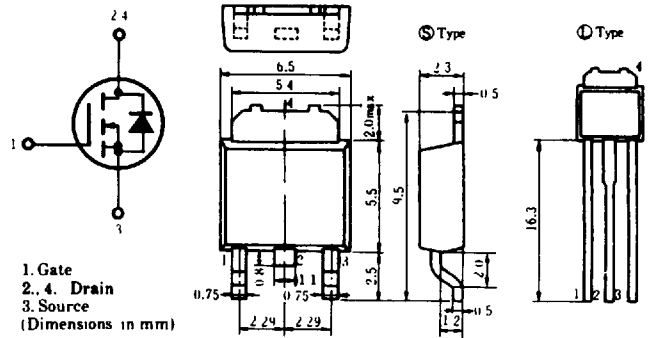

(DPAK)

■ ABSOLUTE MAXIMUM RATINGS ($T_a=25^\circ\text{C}$)

Item	Symbol	Rating	Unit
Drain-Source Voltage	V_{DSS}	40	V
Gate-Source Voltage	V_{GSS}	± 20	V
Drain Current	I_D	2	A
Drain Peak Current	$I_{D(peak)}$	4	A
Body-Drain Diode Reverse Drain Current	I_{DR}	2	A
Channel Dissipation	P_{ch}^*	10	W
Channel Temperature	T_{ch}	150	$^\circ\text{C}$
Storage Temperature	T_{stg}	$-55 \sim +150$	$^\circ\text{C}$

*Value at $T_c=25^\circ\text{C}$

POWER VS. TEMPERATURE DERATING

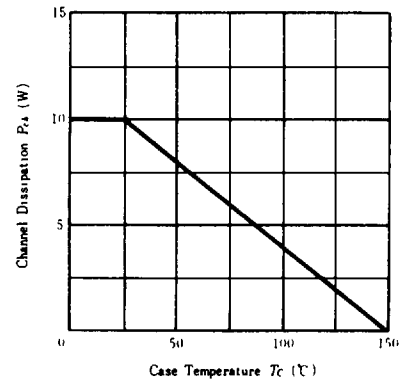

■ ELECTRICAL CHARACTERISTICS ($T_a=25^\circ\text{C}$)

Item	Symbol	Test Condition	min.	typ.	max.	Unit
Drain-Source Breakdown Voltage	$V_{(BR)DSS}$	$I_D=10\text{mA}, V_{GS}=0$	40	—	—	V
Gate-Source Leak Current	I_{GSS}	$V_{GS}=\pm 20\text{V}, V_{DS}=0$	—	—	± 1	μA
Zero Gate Voltage Drain Current	I_{DSS}	$V_{DS}=35\text{V}, V_{GS}=0$	—	—	1	mA
Gate-Source Cutoff Voltage	$V_{GS(off)}$	$I_D=1\text{mA}, V_{DS}=10\text{V}$	1.0	—	4.0	V
Static Drain-Source On State Resistance	$R_{DS(on)}$	$I_D=1\text{A}, V_{GS}=15\text{V}^*$	—	0.5	0.8	Ω
Drain-Source Saturation Voltage	$V_{DS(sat)}$	$I_D=1\text{A}, V_{GS}=15\text{V}^*$	—	0.5	0.8	V
Forward Transfer Admittance	$ y_{fs} $	$I_D=1\text{A}, V_{DS}=10\text{V}^*$	0.2	0.4	—	S
Input Capacitance	C_{iss}	$V_{DS}=10\text{V}, V_{GS}=0$ $f=1\text{MHz}$	—	170	—	pF
Output Capacitance	C_{oss}		—	160	—	pF
Reverse Transfer Capacitance	C_{rss}		—	30	—	pF
Turn-on Delay Time	t_{don}	$I_D=1\text{A}, V_{GS}=15\text{V}$ $R_L=30\Omega$	—	7	—	ns
Rise Time	t_r		—	18	—	ns
Turn-off Delay Time	t_{doff}		—	14	—	ns
Fall Time	t_f		—	21	—	ns
Body-Drain Diode Forward Voltage	V_{DF}	$I_F=1\text{A}, V_{GS}=0$	—	0.9	—	V
Body-Drain Diode Reverse Recovery Time	t_r	$I_F=1\text{A}, V_{GS}=0$ $di_F/dt=50\text{A}/\mu\text{s}$	—	90	—	ns

*Pulse Test

HITACHI OPTOELECTRONIC BLE D

MAXIMUM SAFE OPERATION AREA

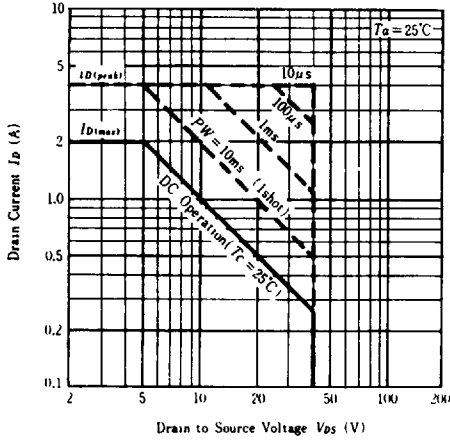

TYPICAL OUTPUT CHARACTERISTICS

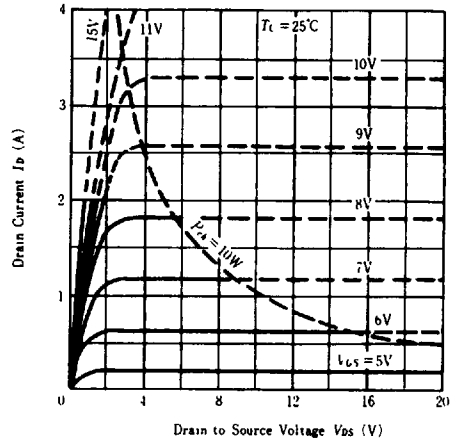

TYPICAL TRANSFER CHARACTERISTICS

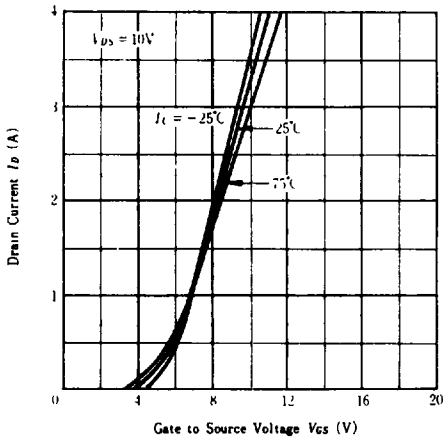

DRAIN-SOURCE SATURATION VOLTAGE VS. GATE-SOURCE VOLTAGE

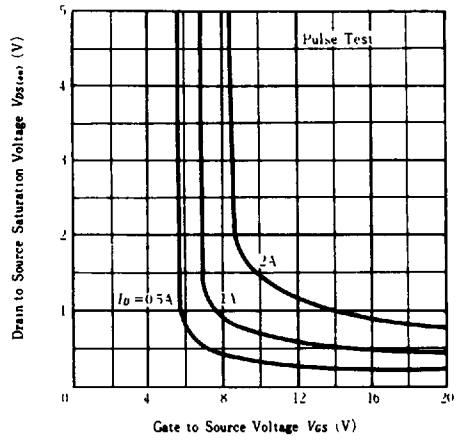

FORWARD TRANSFER ADMITTANCE VS. DRAIN CURRENT

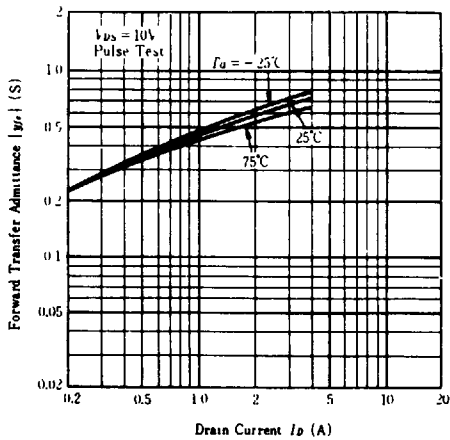

STATIC DRAIN-SOURCE ON STATE RESISTANCE VS. TEMPERATURE

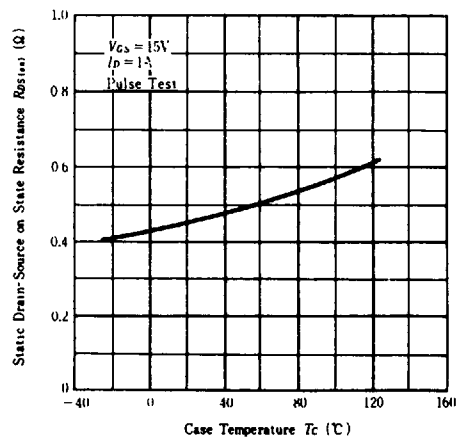

TYPICAL CAPACITANCE VS. DRAIN-SOURCE VOLTAGE

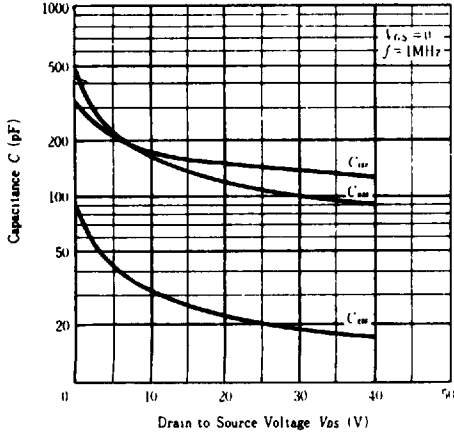

FORWARD TRANSFER ADMITTANCE VS. FREQUENCY

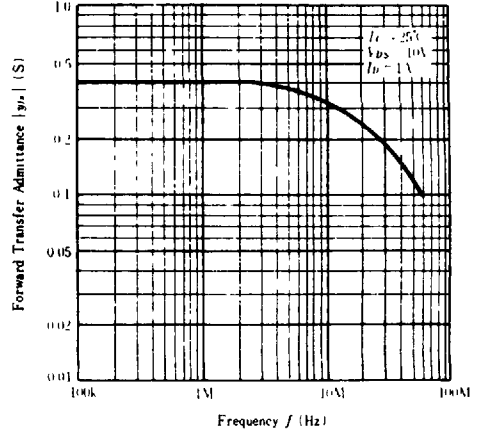

SWITCHING CHARACTERISTICS

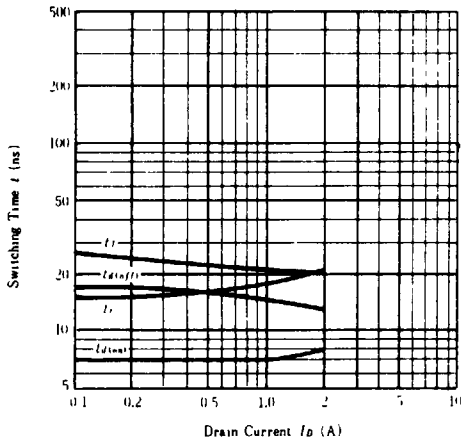

MAXIMUM BODY-DRAIN DIODE FORWARD VOLTAGE

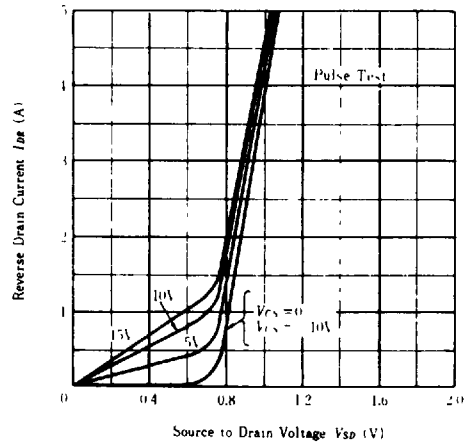

HITACHI/OPTOELECTRONIC

DYNAMIC INPUT CHARACTERISTICS

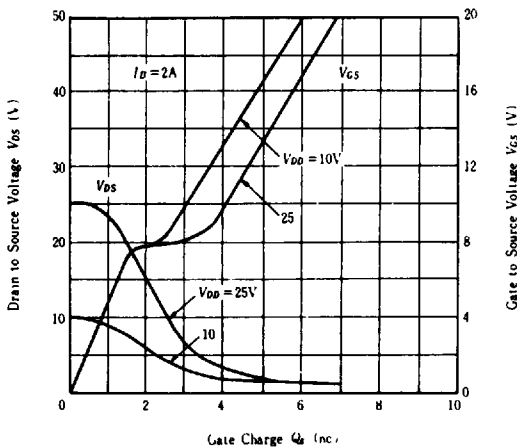

SWITCHING TIME TEST CIRCUIT

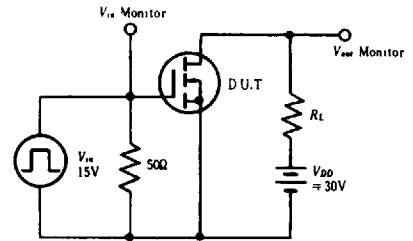

WAVEFORMS

