

3SK297

Silicon N Channel Dual Gate MOS FET

Application

UHF / VHF RF amplifier

Features

- Low noise figure.
NF = 1.0 dB typ. at f = 200 MHz
- Capable of low voltage operation

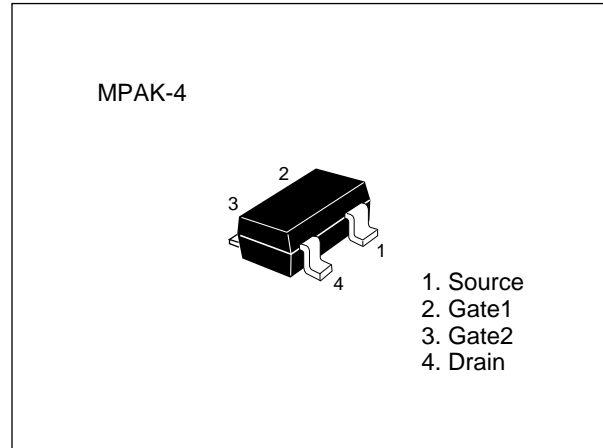

Table 1 Absolute Maximum Ratings (Ta = 25°C)

Item	Symbol	Ratings	Unit
Drain to source voltage	V _{DS}	12	V
Gate1 to source voltage	V _{G1S}	±8	V
Gate2 to source voltage	V _{G2S}	±8	V
Drain current	I _D	25	mA
Channel power dissipation	P _{ch}	150	mW
Channel temperature	T _{ch}	150	°C
Storage temperature	T _{stg}	-55 to +150	°C

Note: Marking is "ZP-"

Attention: This device is very sensitive to electro static discharge.

It is recommended to adopt appropriate cautions when handling this transistor.

3SK297

Table 2 Electrical Characteristics (Ta = 25°C)

Item	Symbol	min.	typ.	max.	Unit	Test conditions
Drain to source breakdown voltage	$V_{(BR)DSX}$	12	—	—	V	$I_D = 200 \mu A, V_{G1S} = -3 V, V_{G2S} = -3 V$
Gate1 to source breakdown voltage	$V_{(BR)G1SS}$	± 8	—	—	V	$I_{G1} = \pm 10 \mu A, V_{G2S} = V_{DS} = 0$
Gate2 to source breakdown voltage	$V_{(BR)G2SS}$	± 8	—	—	V	$I_{G2} = \pm 10 \mu A, V_{G1S} = V_{DS} = 0$
Gate1 cutoff current	I_{G1SS}	—	—	± 100	nA	$V_{G1S} = \pm 6 V, V_{G2S} = V_{DS} = 0$
Gate2 cutoff current	I_{G2SS}	—	—	± 100	nA	$V_{G2S} = \pm 6 V, V_{G1S} = V_{DS} = 0$
Drain current	$I_{DS(on)}$	0.5	—	10	mA	$V_{DS} = 6 V, V_{G1S} = 0.75 V, V_{G2S} = 3 V$
Gate1 to source cutoff voltage	$V_{G1S(off)}$	0	—	+1.0	V	$V_{DS} = 10 V, V_{G2S} = 3V, I_D = 100 \mu A$
Gate2 to source cutoff voltage	$V_{G2S(off)}$	0	—	+1.0	V	$V_{DS} = 10 V, V_{G1S} = 3V, I_D = 100 \mu A$
Forward transfer admittance	$ y_{fs} $	16	20	—	mS	$V_{DS} = 6V, V_{G2S} = 3 V, I_D = 10 mA, f = 1 kHz$
Input capacitance	C_{iss}	2.4	2.9	3.4	pF	$V_{DS} = 6 V, V_{G2S} = 3 V, I_D = 10 mA, f = 1 MHz$
Output capacitance	C_{oss}	0.8	1.0	1.4	pF	
Reverse transfer capacitance	C_{rss}	—	0.023	0.04	pF	
Power gain	PG	22	25	—	dB	$V_{DS} = 6 V, V_{G2S} = 3 V, I_D = 10 mA, f = 200 MHz$
Noise figure	NF	—	1.0	1.8	dB	
Power gain	PG	12	15	—	dB	$V_{DS} = 6 V, V_{G2S} = 3 V, I_D = 10 mA, f = 900 MHz$
Noise figure	NF	—	3.2	4.5	dB	
Noise figure	NF	—	2.8	3.5	dB	$V_{DS} = 6 V, V_{G2S} = 3 V, I_D = 10 mA, f = 60 MHz$

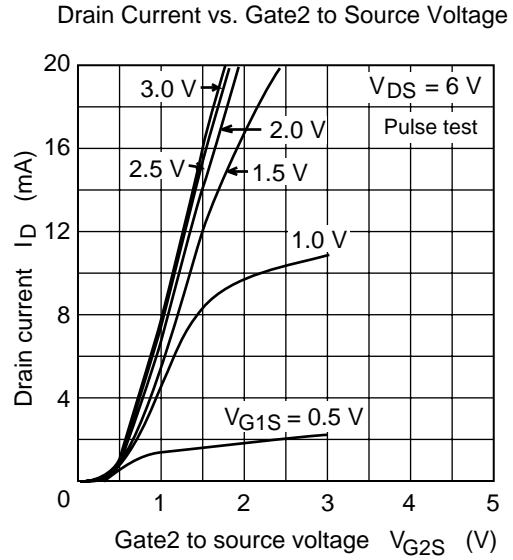
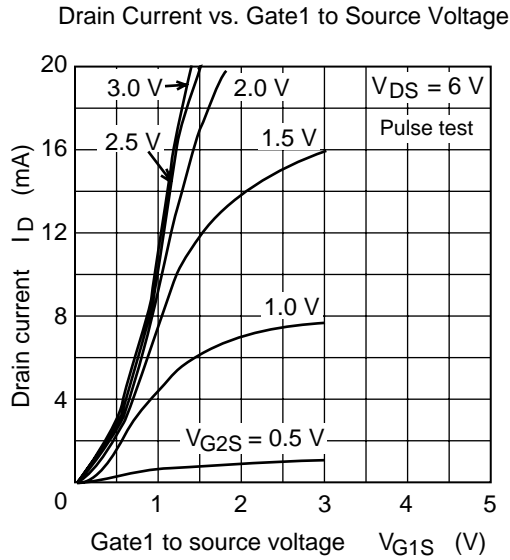
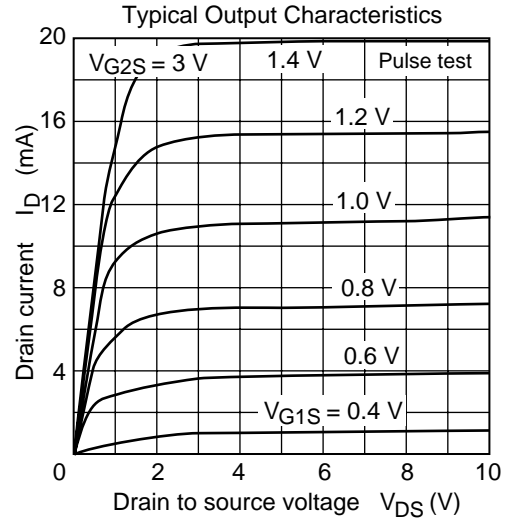
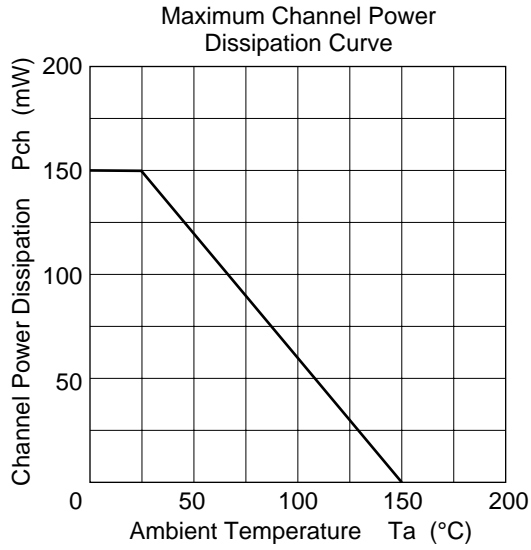

3SK297

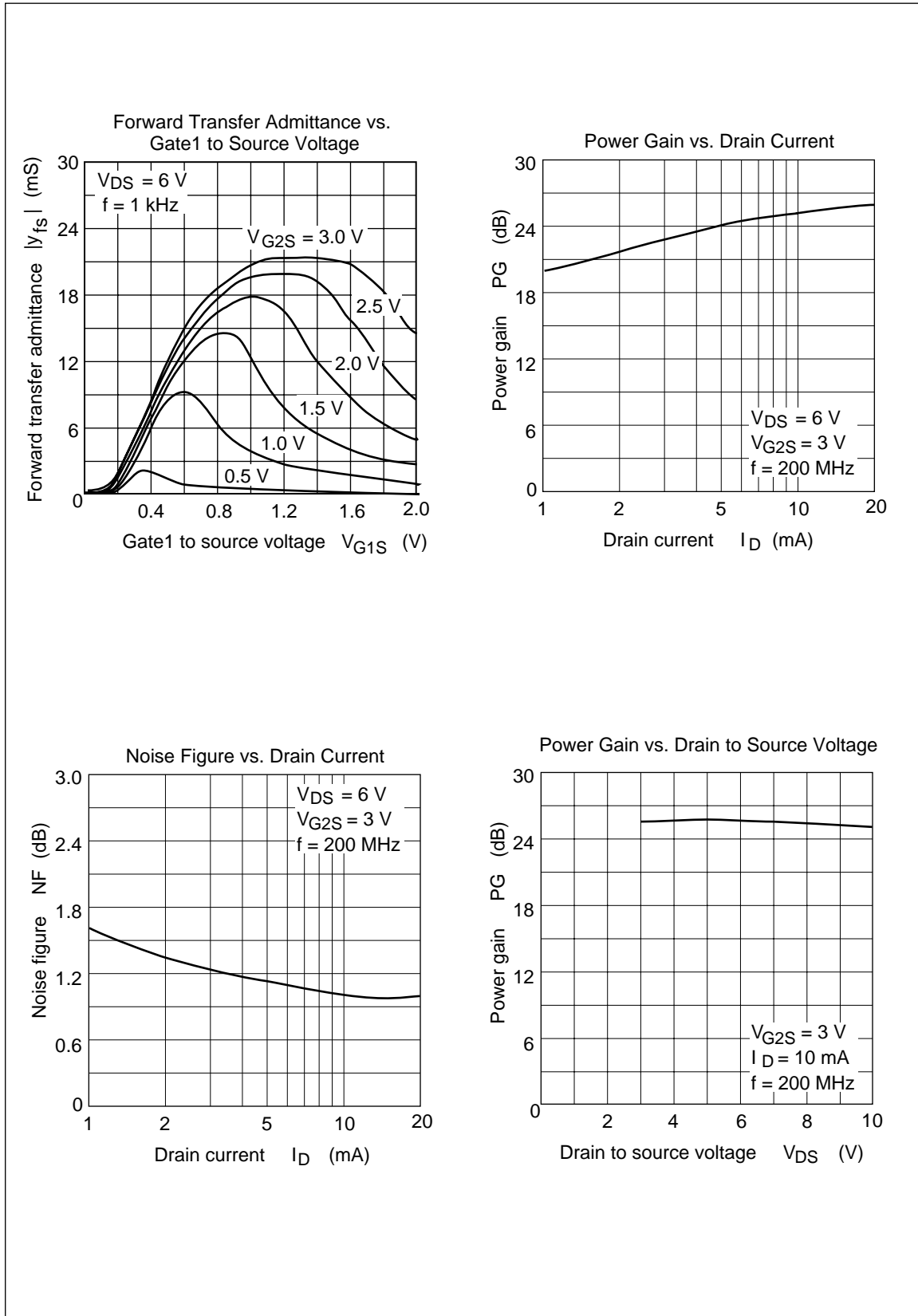

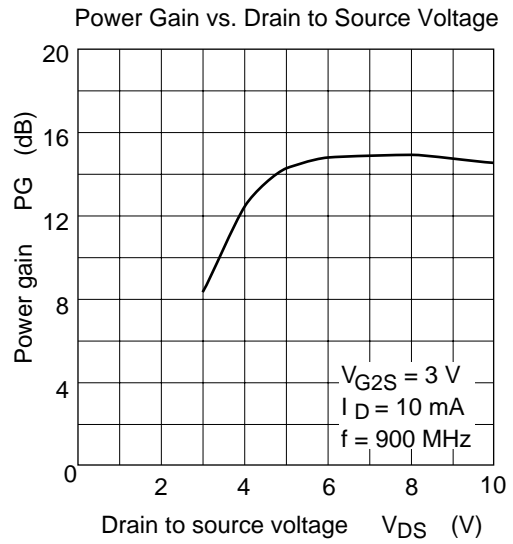
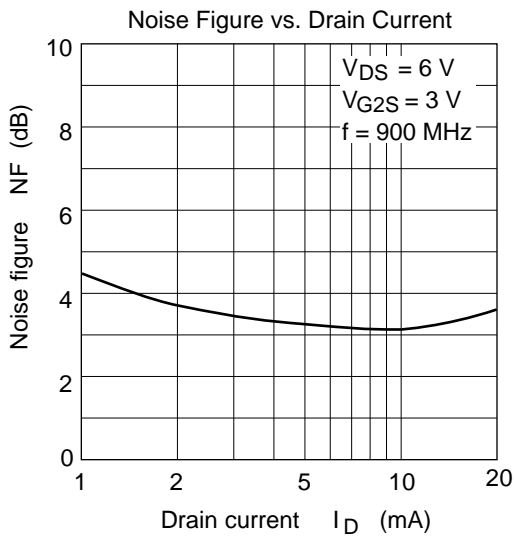
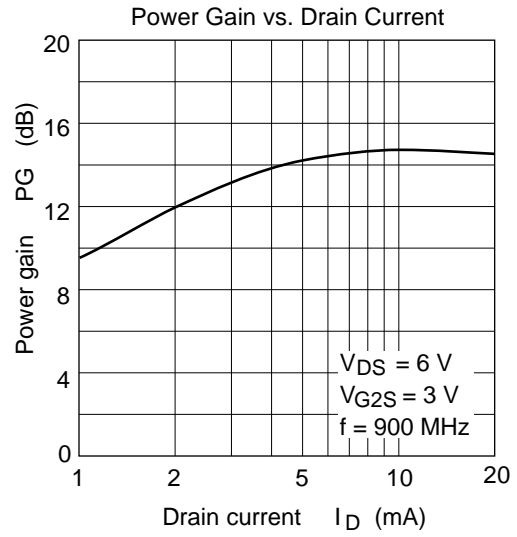
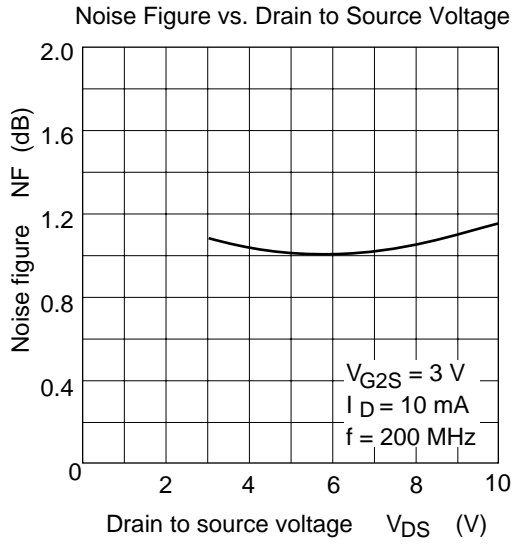

3SK297

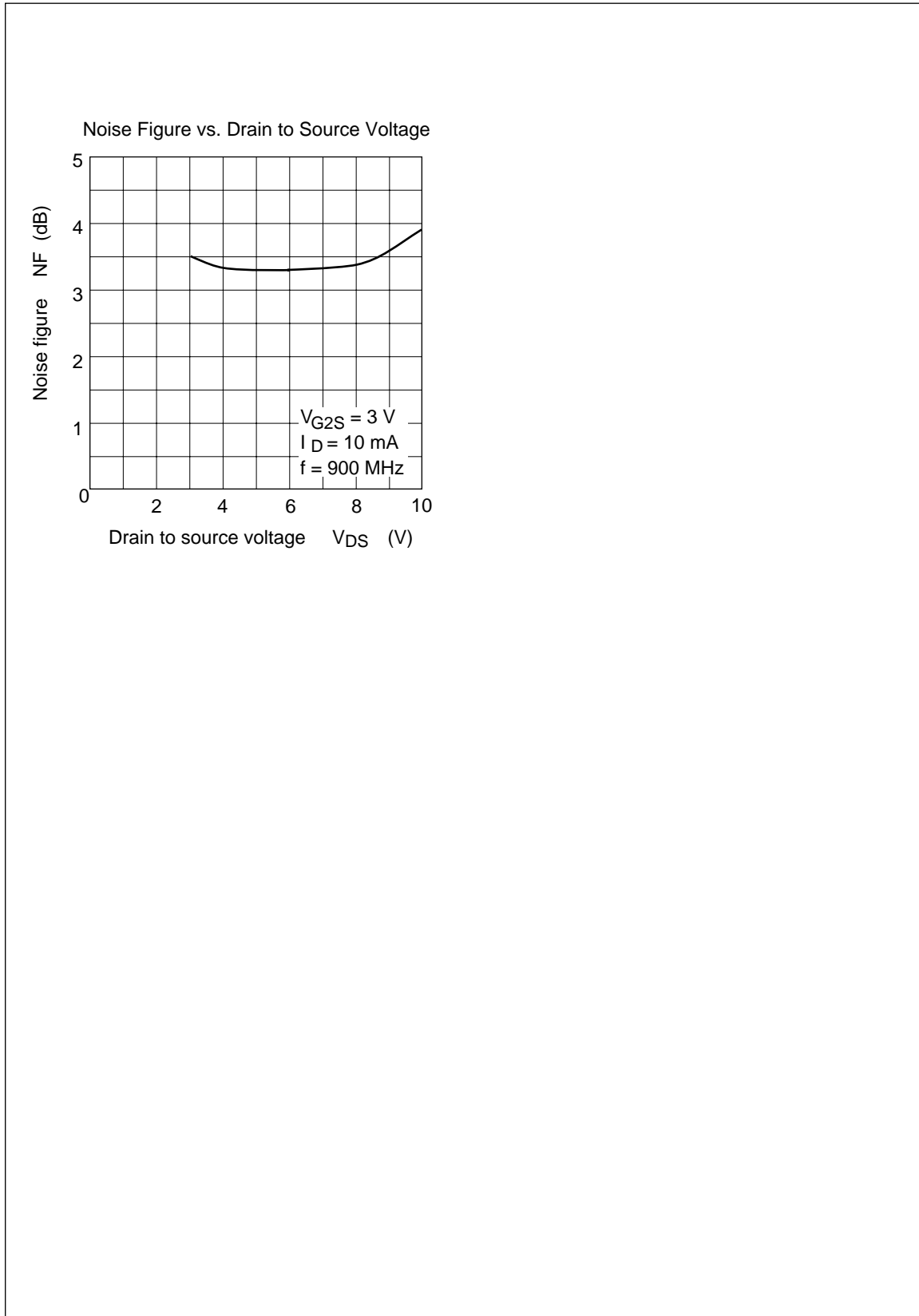

S11 Parameter vs. Frequency

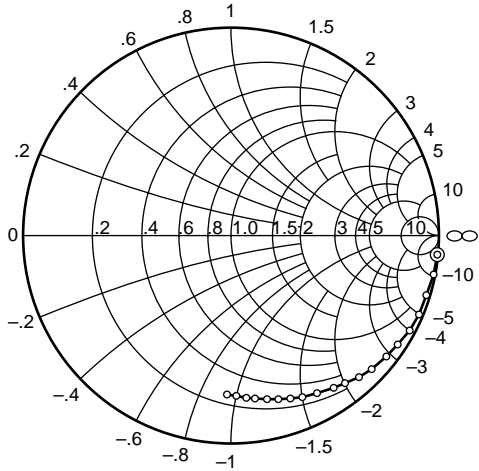

Condition: $V_{DS} = 6\text{ V}$, $V_{G2S} = 3\text{ V}$
 $I_D = 10\text{ mA}$, $Z_0 = 50\ \Omega$
 50 to 1000 MHz (50 MHz step)



S21 Parameter vs. Frequency

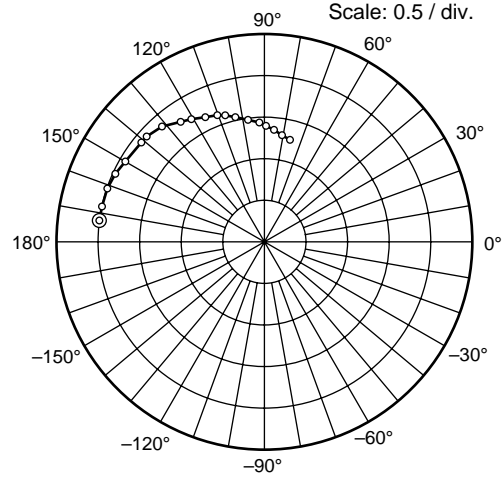

Condition: $V_{DS} = 6\text{ V}$, $V_{G2S} = 3\text{ V}$
 $I_D = 10\text{ mA}$, $Z_0 = 50\ \Omega$
 50 to 1000 MHz (50 MHz step)



S12 Parameter vs. Frequency

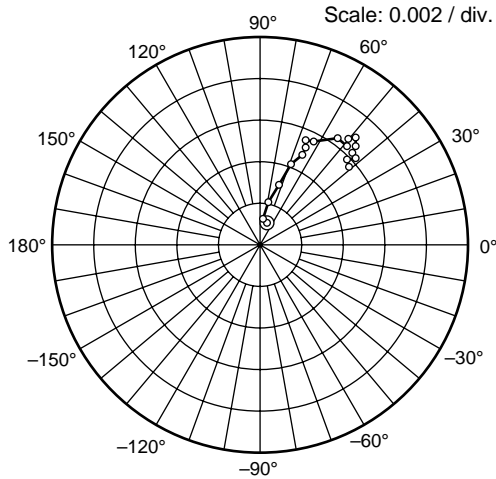

Condition: $V_{DS} = 6\text{ V}$, $V_{G2S} = 3\text{ V}$
 $I_D = 10\text{ mA}$, $Z_0 = 50\ \Omega$
 50 to 1000 MHz (50 MHz step)



S22 Parameter vs. Frequency

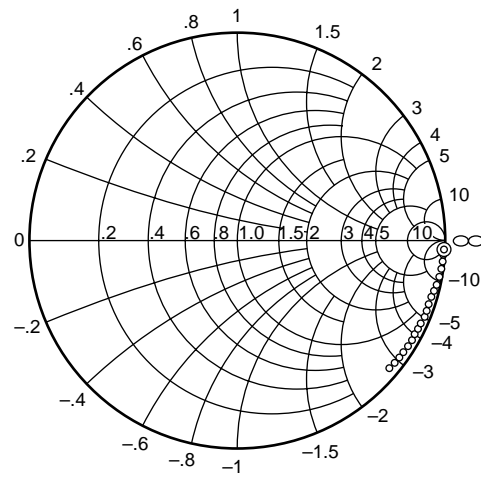

Condition: $V_{DS} = 6\text{ V}$, $V_{G2S} = 3\text{ V}$
 $I_D = 10\text{ mA}$, $Z_0 = 50\ \Omega$
 50 to 1000 MHz (50 MHz step)



3SK297

Table 3 S Parameter ($V_{DS} = 6\text{ V}$, $V_{GS} = 3\text{ V}$, $I_D = 10\text{ mA}$, $Z_O = 50\ \Omega$)

f (MHz)	S11		S21		S12		S22	
	MAG	ANG	MAG	ANG	MAG	ANG	MAG	ANG
50	0.994	-5.8	2.04	173.6	0.00116	76.9	0.993	-2.2
100	0.993	-11.0	2.02	167.4	0.00132	85.7	0.993	-4.5
150	0.986	-16.8	2.00	161.5	0.00229	78.2	0.991	-6.4
200	0.980	-22.5	1.98	155.5	0.00313	73.5	0.990	-8.5
250	0.973	-27.8	1.94	149.6	0.00427	68.7	0.987	-10.5
300	0.950	-33.0	1.90	142.6	0.00473	63.9	0.985	-12.5
350	0.936	-38.3	1.86	137.1	0.00536	64.3	0.982	-14.4
400	0.924	-43.4	1.83	131.6	0.00561	64.5	0.979	-16.2
450	0.912	-48.0	1.77	126.8	0.00562	60.9	0.975	-18.2
500	0.893	-52.5	1.71	121.0	0.00640	53.5	0.971	-20.2
550	0.874	-57.3	1.67	115.5	0.00638	49.3	0.967	-22.0
600	0.859	-62.0	1.64	111.1	0.00647	49.0	0.964	-23.9
650	0.846	-66.1	1.58	106.7	0.00667	50.2	0.960	-25.8
700	0.829	-69.8	1.50	102.1	0.00694	49.3	0.955	-27.6
750	0.810	-74.2	1.46	97.1	0.00661	46.6	0.952	-29.4
800	0.802	-78.0	1.44	92.7	0.00618	43.7	0.948	-31.2
850	0.791	-81.6	1.38	88.9	0.00622	44.7	0.944	-33.2
900	0.778	-84.6	1.34	84.2	0.00615	43.6	0.940	-35.1
950	0.756	-88.5	1.30	80.2	0.00576	45.1	0.935	-36.8
1000	0.751	-92.2	1.26	75.9	0.00562	40.7	0.932	-38.5

Package Dimensions

Unit : mm

