3SK309

GaAs N Channel Dual Gate MES FET
UHF RF Amplifier

HITACHI

ADE-208-472 A (Z)
2nd. Edition
November. 1996

Features

- Capable of low voltage operation ($V_{DS} = 1.5$ to 3 V)
- Excellent low noise characteristics
($NF = 1.25$ dB typ. at $f = 900$ MHz)
- High power gain
($PG = 21.0$ dB typ. at $f = 900$ MHz)

Outline

CMPAK-4

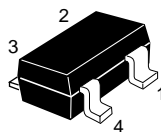

1. Source
2. Gate1
3. Gate2
4. Drain

3SK309

Absolute Maximum Ratings (Ta = 25°C)

Item	Symbol	Ratings	Unit
Drain to source voltage	VDS	6	V
Gate1 to source voltage	VG1S	-4	V
Gate 2 to source voltage	VG2S	-4	V
Drain current	ID	18	mA
Channel power dissipation	Pch	100	mW
Channel temperature	Tch	125	°C
Storage temperature	Tstg	-55 to +125	°C

Electrical Characteristics (Ta = 25°C)

Item	Symbol	Min	Typ	Max	Unit	Test Conditions
Gate1 to cutoff current	IG1SS	—	—	-20	μA	VG1S = -4V VG2S = VDS = 0
Gate2 to cutoff current	IG2SS	—	—	-20	μA	VG2S = -4V VG1S = VDS = 0
Gate1 to source cutoff voltage	VG1S(off)	-0.2	—	-1.5	V	VDS = 3V, VG2S = 0 ID = 100μA
Gate2 to source cutoff voltage	VG2S(off)	-0.2	—	-1.5	V	VDS = 3V, VG1S = 0 ID = 100μA
Zero gate voltage drain current	IDSS	25	40	60	mA	VDS = 3 V, VG1S = 0 VG2S = 0
Forward transfer admittance	yfs	30	40	—	mS	VDS = 3V, VG2S = 0 ID = 5mA
Power gain	PG	18	21	—	dB	VDS = 3V, VG2S = 0
Noise figure	NF	—	1.25	1.5	dB	ID = 5mA, f = 900MHz
Power gain	PG	—	20	—	dB	VDS = 1.5V, VG2S = 0
Noise figure	NF	—	1.3	—	dB	ID = 3mA, f = 900MHz

Note: 1 Markig is "XV-".

Main Characteristics

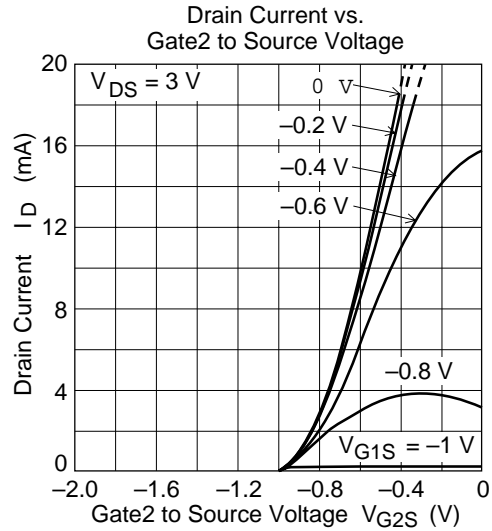
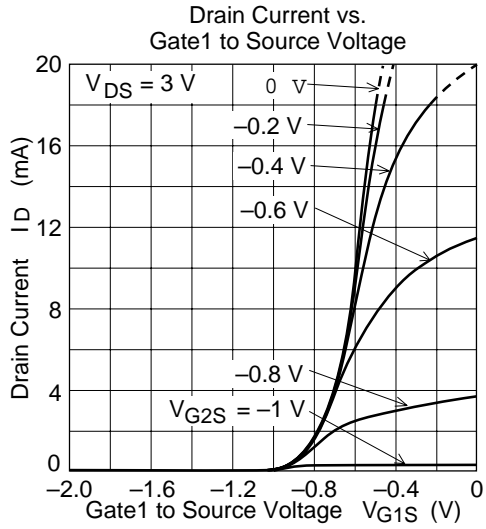
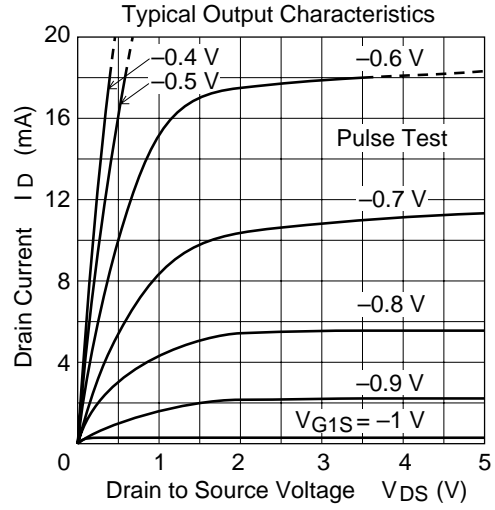
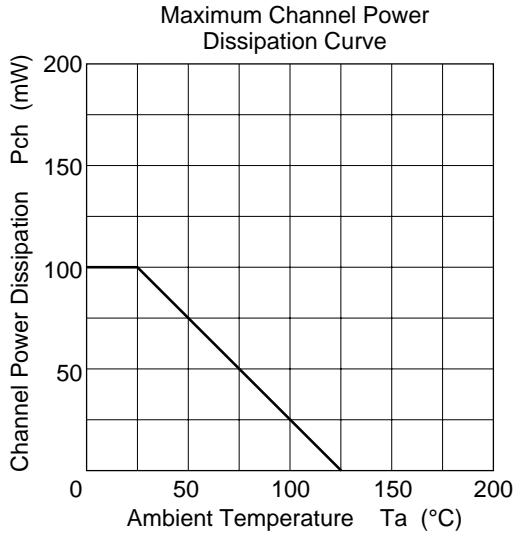

3SK309

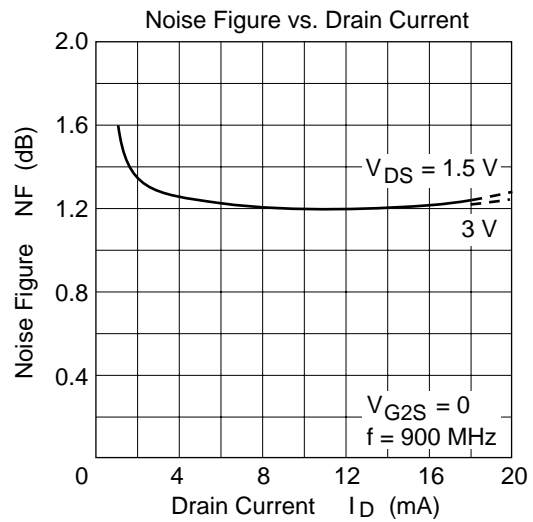
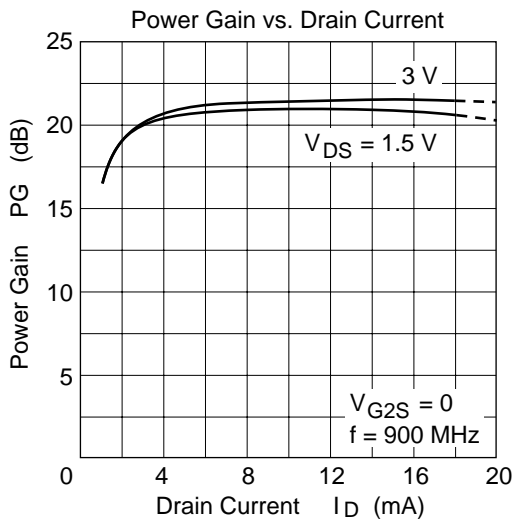
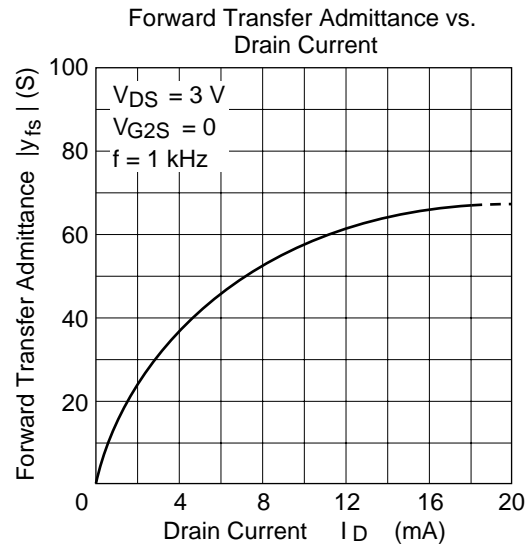
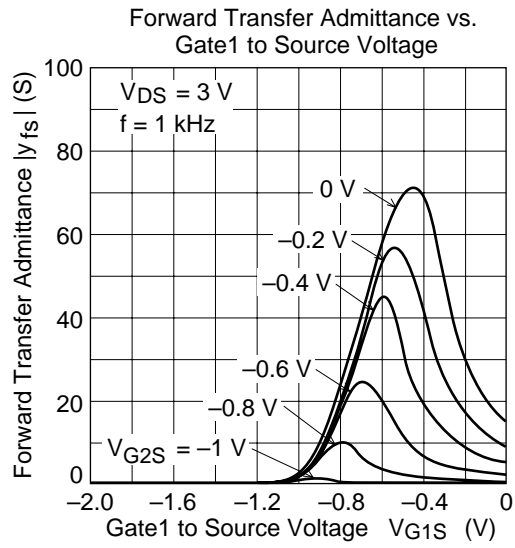

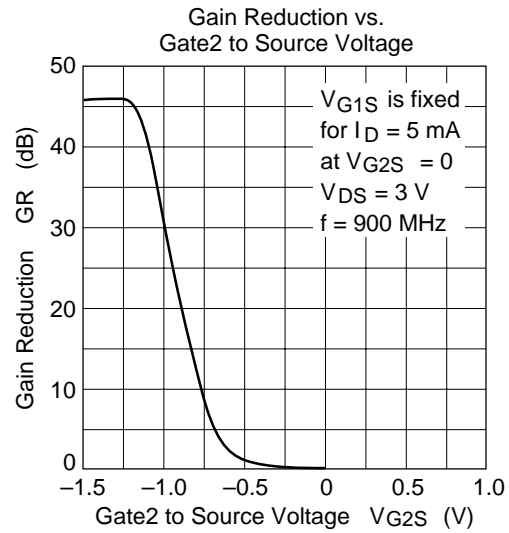
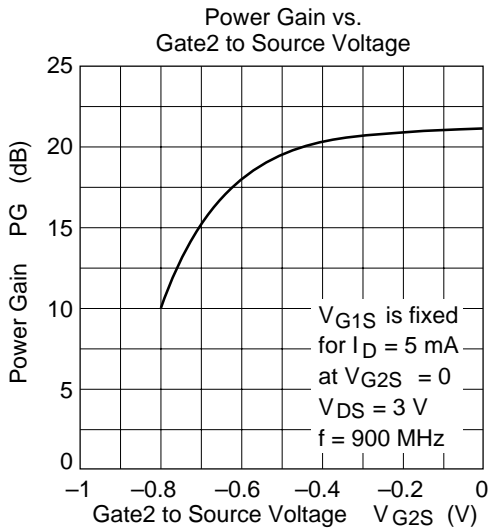
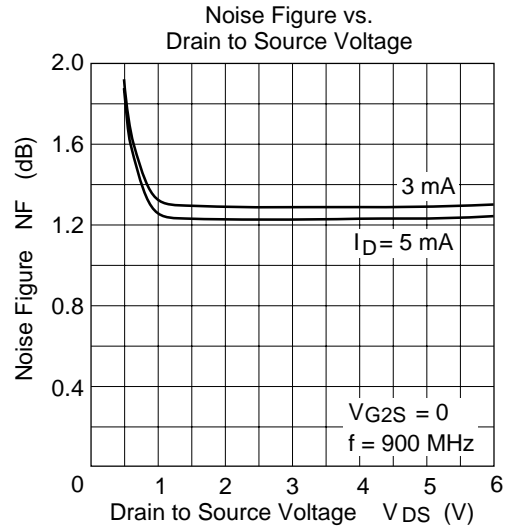
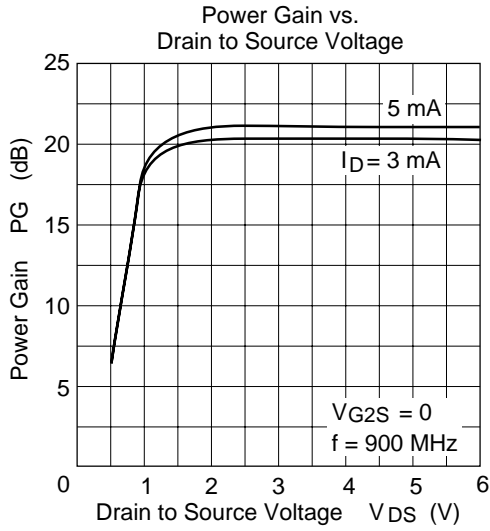

3SK309

S11 Parameter vs. Frequency

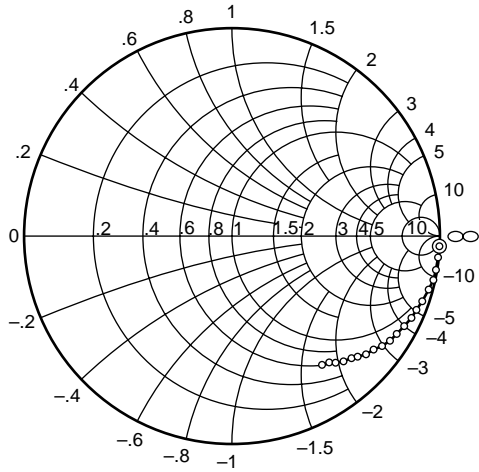

Test Condition: $V_{DS} = 3\text{ V}$, $V_{G2S} = 0\text{ V}$
 $I_D = 5\text{ mA}$, $Z_0 = 50\ \Omega$
 100 to 2000 MHz (100 MHz step)

⊙—○

S21 Parameter vs. Frequency

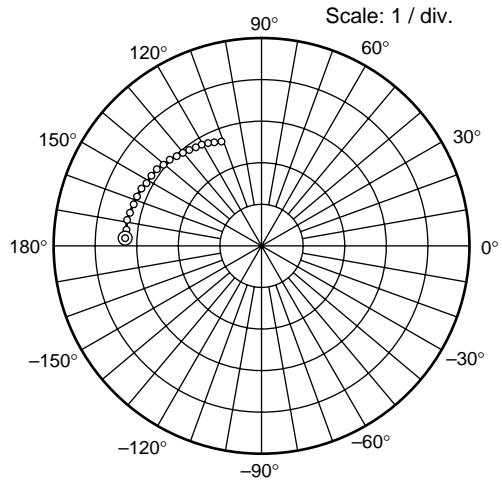

Test Condition: $V_{DS} = 3\text{ V}$, $V_{G2S} = 0\text{ V}$
 $I_D = 5\text{ mA}$, $Z_0 = 50\ \Omega$
 100 to 2000 MHz (100 MHz step)

⊙—○

S12 Parameter vs. Frequency

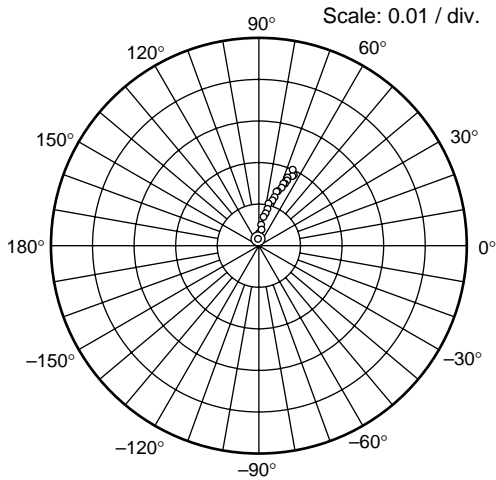

Test Condition: $V_{DS} = 3\text{ V}$, $V_{G2S} = 0\text{ V}$
 $I_D = 5\text{ mA}$, $Z_0 = 50\ \Omega$
 100 to 2000 MHz (100 MHz step)

⊙—○

S22 Parameter vs. Frequency

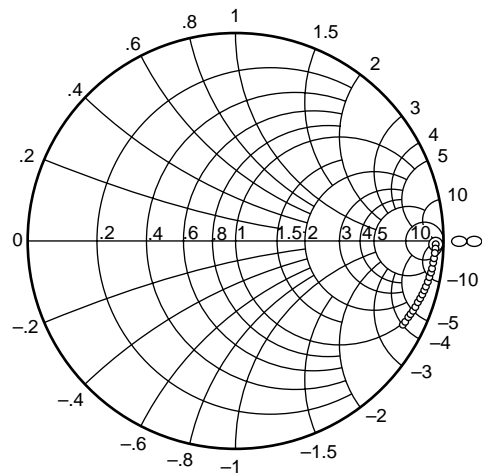

Test Condition: $V_{DS} = 3\text{ V}$, $V_{G2S} = 0\text{ V}$
 $I_D = 5\text{ mA}$, $Z_0 = 50\ \Omega$
 100 to 2000 MHz (100 MHz step)

⊙—○

Sparameter (VDS = 3V, VG2S = 0, ID = 5mA, Zo = 50Ω)

f (MHz)	S11		S21		S12		S22	
	MAG	ANG	MAG	ANG	MAG	ANG	MAG	ANG
100	0.999	-2.8	3.29	176.7	0.00167	95.2	0.963	-0.9
200	0.997	-5.9	3.27	173.1	0.00302	89.0	0.963	-2.2
300	0.995	-9.4	3.29	169.0	0.00394	80.5	0.961	-3.5
400	0.992	-12.3	3.26	165.8	0.00506	83.7	0.959	-5.0
500	0.981	-15.2	3.23	161.9	0.00703	80.8	0.957	-6.3
600	0.968	-18.9	3.22	158.3	0.00797	78.1	0.955	-8.0
700	0.956	-21.8	3.20	154.4	0.00911	76.9	0.953	-9.2
800	0.949	-24.5	3.15	151.3	0.0104	77.1	0.949	-10.6
900	0.935	-27.6	3.14	147.4	0.0114	73.2	0.946	-12.0
1000	0.922	-30.7	3.12	143.7	0.0123	72.1	0.942	-13.5
1100	0.912	-33.5	3.06	140.3	0.0137	71.9	0.939	-14.7
1200	0.895	-36.2	3.03	136.7	0.0139	70.8	0.935	-16.0
1300	0.873	-38.7	2.97	133.3	0.0150	68.5	0.931	-17.3
1400	0.860	-41.4	2.93	130.1	0.0161	68.5	0.926	-18.6
1500	0.838	-43.8	2.89	126.9	0.0162	67.2	0.922	-20.2
1600	0.822	-45.6	2.85	123.6	0.0171	66.6	0.918	-21.5
1700	0.807	-48.3	2.83	120.5	0.0178	67.2	0.913	-22.7
1800	0.787	-50.7	2.79	117.4	0.0185	66.0	0.909	-23.8
1900	0.767	-52.4	2.74	114.4	0.0186	64.3	0.905	-25.5
2000	0.756	-55.0	2.69	110.9	0.0190	63.7	0.901	-26.6

3SK309

Power Gain, Noise Figure Test Circuit

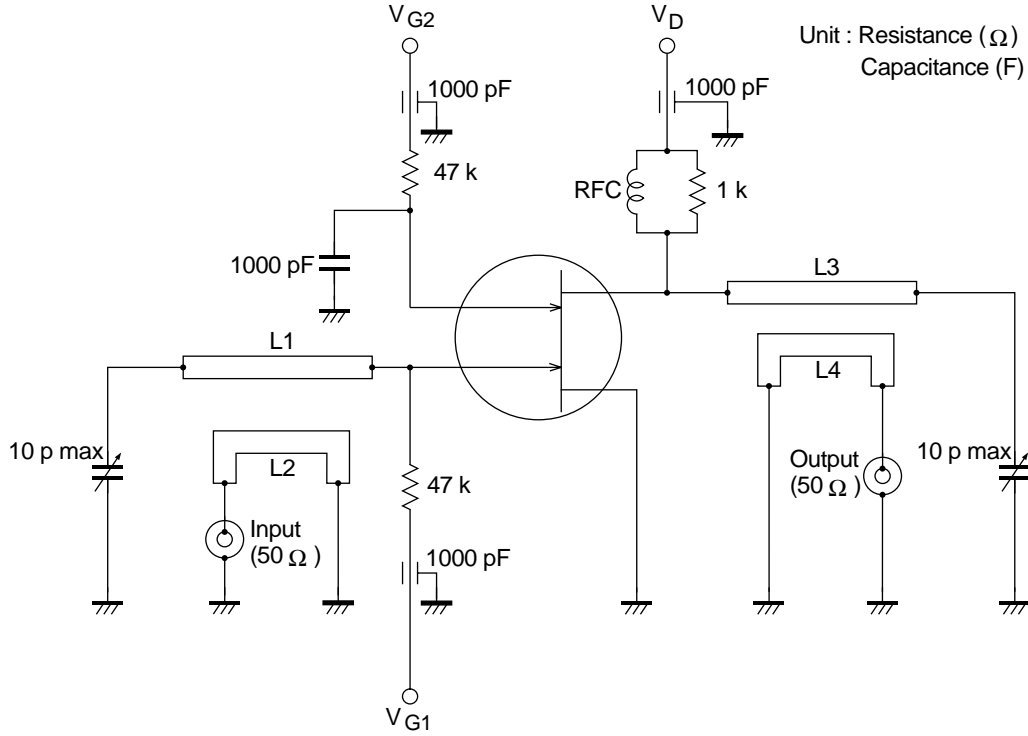

L1 to L4 : ϕ 1 mm copper wire

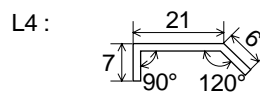
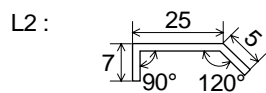
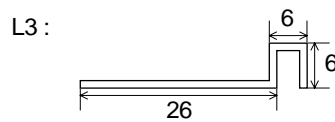
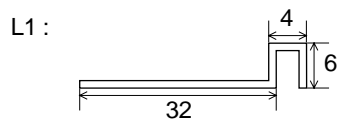

Unit : mm

RFC : 3 turn, 6 mm inside dia (ϕ 1 mm enameled copper wire)

Package Dimensions

Unit: mm

