

74ABT16952

16-Bit Registered Transceiver with 3-STATE Outputs

General Description

The ABT16952 is a 16-bit registered transceiver. Two 8-bit back to back registers store data flowing in both directions between two bidirectional buses. Separate clock, clock enable and 3-STATE output enable signals are provided for each register. The output pins are guaranteed to source 32 mA and to sink 64 mA.

Features

- Separate clock, clock enable and 3-STATE output enable provided for each register
- A and B output sink capability of 64 mA source capability of 32 mA
- Guaranteed latchup protection
- High impedance glitch free bus loading during entire power up and power down cycle
- Nondestructive hot insertion capability

Ordering Code:

Order Number	Package Number	Package Description
74ABT16952CSSC	MS56A	56-Lead Shrink Small Outline Package (SSOP), JEDEC MO-118, 0.300" Wide
74ABT16952CMTD	MTD56	56-Lead Thin Shrink Small Outline Package (TSSOP), JEDEC MO-153, 6.1mm Wide

Devices also available in Tape and Reel. Specify by appending the letter suffix "X" to the ordering code.

Pin Descriptions

Pin Names	Description
A ₀ -A ₁₅	Data Register A Inputs/ B-Register 3-STATE Outputs
B ₀ -B ₁₅	Data Register B Inputs/ A-Register 3-STATE Outputs
CPAB _n , CPBA _n	Clock Pulse Inputs
\overline{CEA}_n , \overline{CEB}_n	Clock Enable
\overline{OEAB}_n , \overline{OEBAn}	Output Enable Inputs

Connection Diagram

Pin Assignment for SSOP

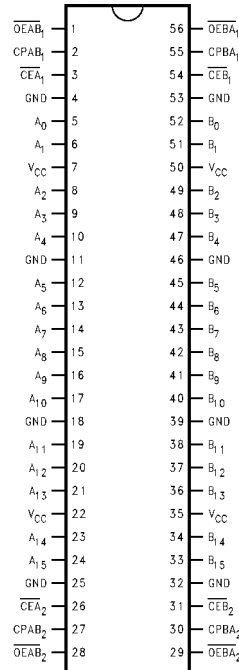

Output Control

OE	Internal Q	Output	Function
H	X	Z	Disable Outputs
L	L	L	Enable Outputs
L	H	H	

Register Function Table

(Applies to A or B Register)

Inputs			Internal	Function
D	CP	\overline{CE}	Q	
X	X	H	NC	Hold Data
L	↗	L	L	Load Data
H	↗	L	H	

H = HIGH Voltage Level
L = LOW Voltage Level
X = Immaterial
Z = HIGH Impedance
↗ = LOW-to-HIGH Transition
NC = No Change

74ABT16952 16-Bit Registered Transceiver with 3-STATE Outputs

Block Diagram

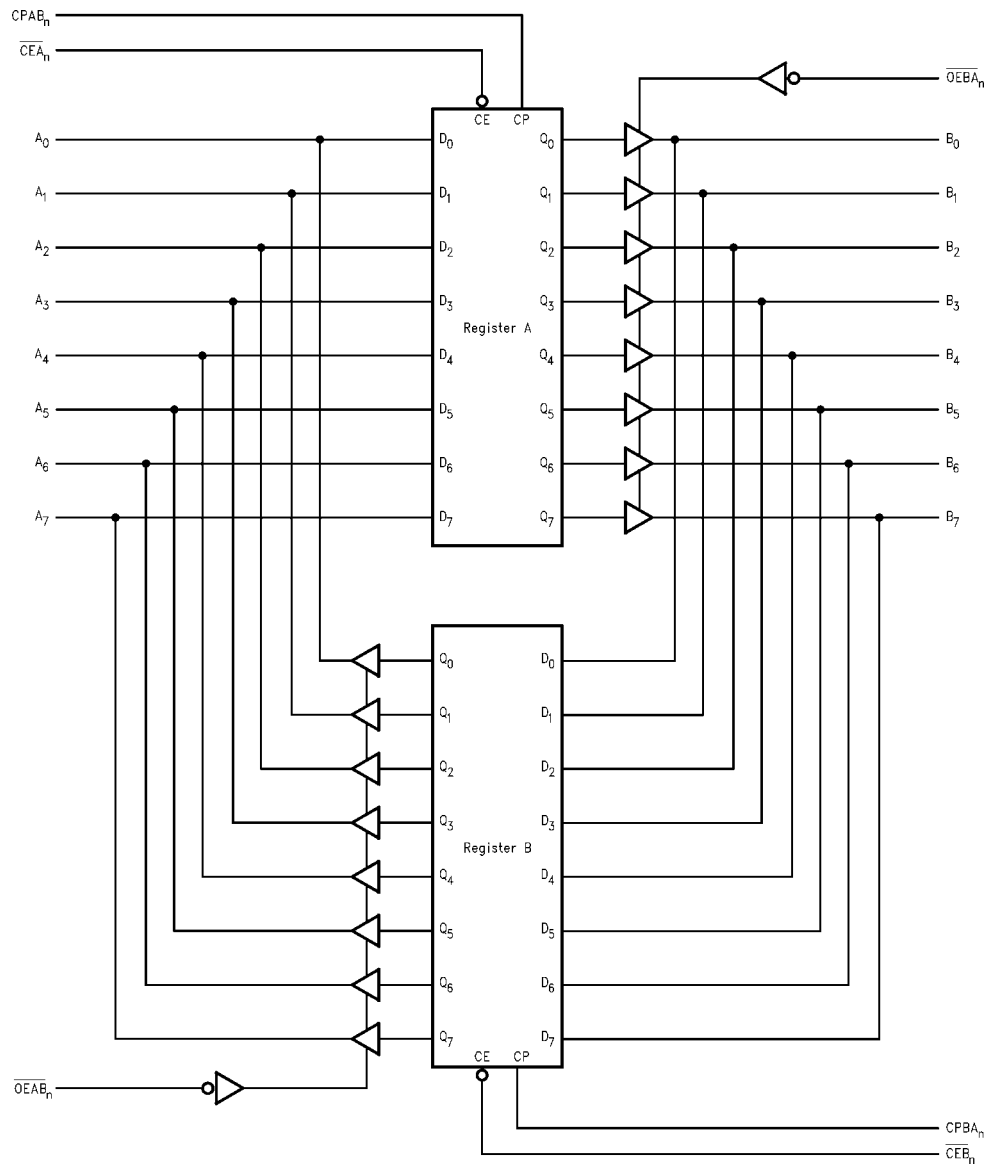

n for either byte 1 or byte 2

Absolute Maximum Ratings (Note 1)		DC Latchup Source Current	-500 mA
Storage Temperature	-65°C to +150°C	Over Voltage Latchup (I/O)	10V
Ambient Temperature under Bias	-55°C to +125°C	Recommended Operating Conditions	
Junction Temperature under Bias	-55°C to +150°C	Free Air Ambient Temperature	-40°C to +85°C
V _{CC} Pin Potential to Ground Pin	-0.5V to +7.0V	Supply Voltage	+4.5V to +5.5V
Input Voltage (Note 2)	-0.5V to +7.0V	Minimum Input Edge Rate ($\Delta V/\Delta t$)	
Input Current (Note 2)	-30 mA to +5.0 mA	Data Input	50 mV/ns
Voltage Applied to Any Output in the Disable or Power-Off State	-0.5V to +5.5V	Enable Input	20 mV/ns
Voltage Applied to Any Output in the HIGH State	-0.5V to V _{CC}	Clock Input	100 mV/ns
Current Applied to Output in LOW State (Max)	twice the rated I _{OL} (mA)	Note 1: Absolute maximum ratings are values beyond which the device may be damaged or have its useful life impaired. Functional operation under these conditions is not implied. Note 2: Either voltage limit or current limit is sufficient to protect inputs.	

DC Electrical Characteristics

Symbol	Parameter	Min	Typ	Max	Units	V _{CC}	Conditions
V _{IH}	Input HIGH Voltage	2.0			V		Recognized HIGH Signal
V _{IL}	Input LOW Voltage			0.8	V		Recognized LOW Signal
V _{CD}	Input Clamp Diode Voltage			-1.2	V	Min	I _{IN} = -18 mA (Non I/O Pins)
V _{OH}	Output HIGH Voltage	2.5					I _{OH} = -3 mA (A _n , B _n) I _{OH} = -32 mA (A _n , B _n)
V _{OL}	Output LOW Voltage			0.55			I _{OL} = 64 mA (A _n , B _n)
V _{ID}	Input Leakage Test	4.75			V	0.0	I _{ID} = 1.9 μ A (Non-I/O Pins) All Other Pins Grounded
I _{IH}	Input HIGH Current			1	μ A	Max	V _{IN} = 2.7V (Non-I/O Pins) (Note 4) V _{IN} = V _{CC} (Non-I/O Pins)
I _{BVI}	Input HIGH Current Breakdown Test			7	μ A	Max	V _{IN} = 7.0V (Non-I/O Pins)
I _{BVIT}	Input HIGH Current Breakdown Test (I/O)			100	μ A	Max	V _{IN} = 5.5V (A _n , B _n)
I _{IL}	Input LOW Current			-1	μ A	Max	V _{IN} = 0.5V (Non-I/O Pins) (Note 4) V _{IN} = 0.0V (Non-I/O Pins)
I _{IH} + I _{OZH}	Output Leakage Current			10	μ A	0V-5.5V	V _{OUT} = 2.7V (A _n , B _n); OE \bar{A} or OE \bar{B} = 2.0V
I _{IL} + I _{OZL}	Output Leakage Current			-10	μ A	0V-5.5V	V _{OUT} = 0.5V (A _n , B _n); OE \bar{A} or OE \bar{B} = 2.0V
I _{OS}	Output Short-Circuit Current	-100		-275	mA	Max	V _{OUT} = 0V (A _n , B _n)
I _{CEX}	Output HIGH Leakage Current			50	μ A	Max	V _{OUT} = V _{CC} (A _n , B _n)
I _{ZZ}	Bus Drainage Test			100	μ A	0.0V	V _{OUT} = 5.5V (A _n , B _n); All Others GND
I _{CCH}	Power Supply Current			1.0	mA	Max	All Outputs HIGH
I _{CCL}	Power Supply Current			60	mA	Max	All Outputs LOW
I _{CCZ}	Power Supply Current			1.0	mA	Max	Outputs 3-STATE; All Others GND
I _{CCT}	Additional I _{CC} /Input			2.5	mA	Max	V _I = V _{CC} - 2.1V; All Others at V _{CC} or GND
I _{CCD}	Dynamic I _{CC} (Note 4)	No Load		0.18	mA/MHz	Max	Outputs Open OE \bar{A} or OE \bar{B} = GND, Non-I/O = GND or V _{CC} One Bit toggling, 50% duty cycle (Note 3)

Note 3: For 8-bit toggling, I_{CCD} < 1.4 mA/MHz.

Note 4: Guaranteed, but not tested.

AC Electrical Characteristics						
(SSOP Package)						
Symbol	Parameter	$T_A = +25^\circ\text{C}$ $V_{CC} = +5.0\text{V}$ $C_L = 50\text{ pF}$		$T_A = -40^\circ\text{C to } +85^\circ\text{C}$ $V_{CC} = 4.5\text{V to } 5.5\text{V}$ $C_L = 50\text{ pF}$		Units
		Min	Max	Min	Max	
f_{max}	Max Clock Frequency	200		200		MHz
t_{PLH} t_{PHL}	Propagation Delay CPAB _n or CPBA _n to A _n or B _n	1.5	5.3	1.5	5.3	ns
t_{PZH} t_{PZL}	Output Enable Time $\overline{\text{OEAB}}_n$ or $\overline{\text{OEB}}_n$ to A _n or B _n	1.5	5.5	1.5	5.5	ns
t_{PHZ} t_{PLZ}	Output Disable Time $\overline{\text{OEAB}}_n$ or $\overline{\text{OEB}}_n$ to A _n or B _n	1.5	6.0	1.5	6.0	ns
AC Operating Requirements						
Symbol	Parameter	$T_A = +25^\circ\text{C}$ $V_{CC} = +5.0\text{V}$ $C_L = 50\text{ pF}$		$T_A = -40^\circ\text{C to } +85^\circ\text{C}$ $V_{CC} = 4.5\text{V to } 5.5\text{V}$ $C_L = 50\text{ pF}$		Units
		Min	Max	Min	Max	
$t_{\text{S(H)}}$ $t_{\text{S(L)}}$	Setup Time, HIGH or LOW A _n or B _n to $\overline{\text{CPAB}}_n$ or $\overline{\text{CPBA}}_n$	2.5		2.5		ns
$t_{\text{H(H)}}$ $t_{\text{H(L)}}$	Hold Time, HIGH or LOW A _n or B _n to CPAB _n or CPBA _n	1.5		1.5		ns
$t_{\text{S(H)}}$ $t_{\text{S(L)}}$	Setup Time, HIGH or LOW $\overline{\text{CEA}}_n$ or $\overline{\text{CEB}}_n$ to $\overline{\text{CPAB}}_n$ or $\overline{\text{CPBA}}_n$	2.5		2.5		ns
$t_{\text{H(H)}}$ $t_{\text{H(L)}}$	Hold Time, HIGH or LOW $\overline{\text{CEA}}_n$ or $\overline{\text{CEB}}_n$ to $\overline{\text{CPAB}}_n$ or $\overline{\text{CPBA}}_n$	1.5		1.5		ns
$t_{\text{W(H)}}$ $t_{\text{W(L)}}$	Pulse Width, HIGH or LOW to $\overline{\text{CPAB}}_n$ or $\overline{\text{CPBA}}_n$	3.0		3.0		ns
Capacitance						
Symbol	Parameter	Typ	Units	Conditions $T_A = 25^\circ\text{C}$		
C_{IN}	Input Capacitance	5	pF	$V_{CC} = 0\text{V}$ (Non I/O Pins)		
$C_{\text{I/O}}$ (Note 5)	Output Capacitance	11	pF	$V_{CC} = 5.0\text{V}$ (A _n , B _n)		
Note 5: $C_{\text{I/O}}$ is measured at frequency $f = 1\text{ MHz}$, per MIL-STD-883, Method 3012.						

AC Loading

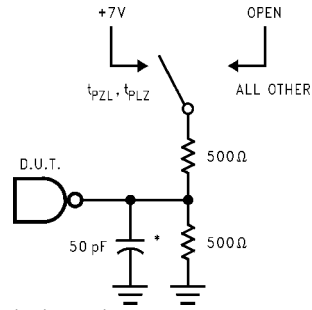

*Includes jig and probe capacitance

FIGURE 1. Standard AC Test Load

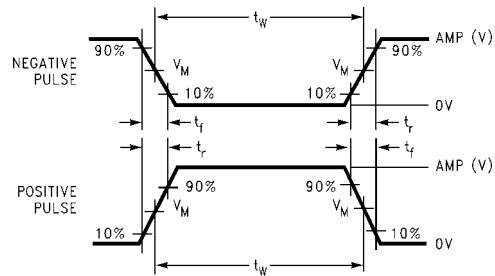

$V_M = 1.5V$

FIGURE 2. Test Input Signal Levels

Amplitude	Rep. Rate	t_w	t_r	t_f
3.0V	1 MHz	500 ns	2.5 ns	2.5 ns

FIGURE 3. Input Signal Requirements

AC Waveforms

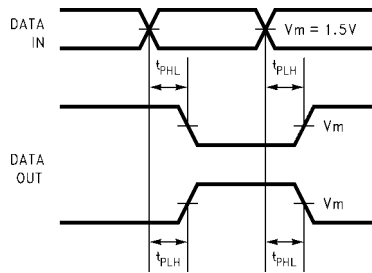

FIGURE 4. Propagation Delay Waveforms for Inverting and Non-Inverting Functions

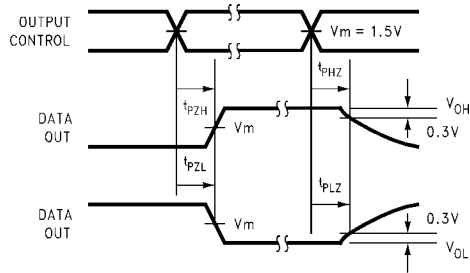

FIGURE 6. 3-STATE Output HIGH and LOW Enable and Disable Times

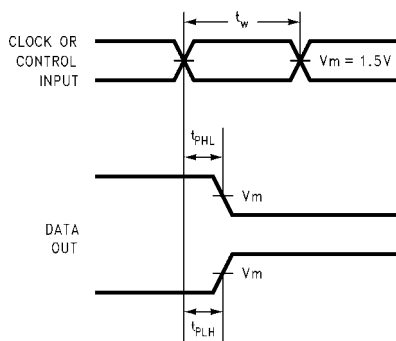

FIGURE 5. Propagation Delay, Pulse Width Waveforms

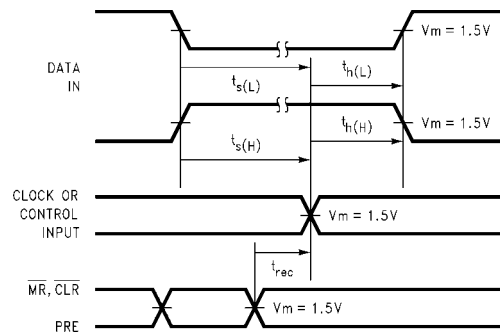
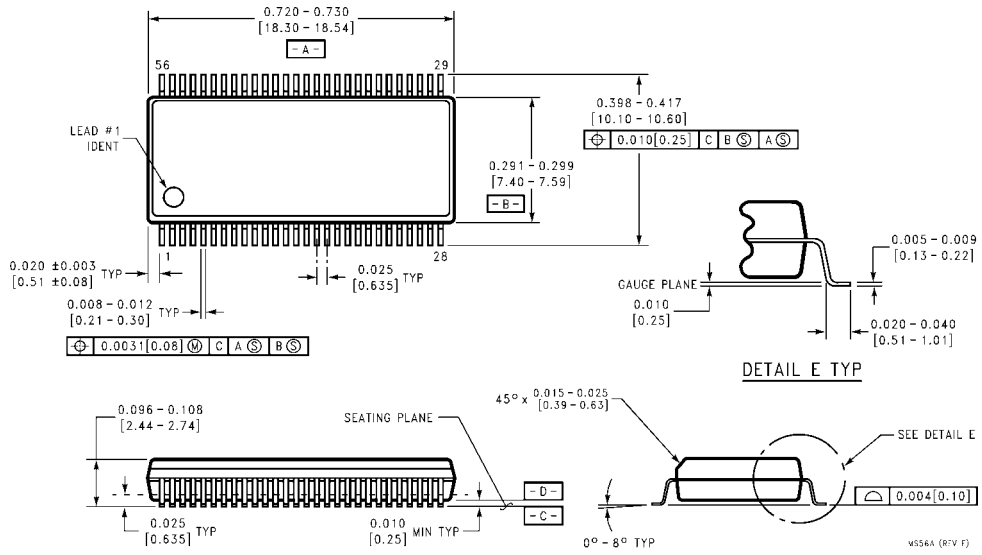

FIGURE 7. Setup Time, Hold Time and Recovery Time Waveforms

Physical Dimensions inches (millimeters) unless otherwise noted



**56-Lead Shrink Small Outline Package (SSOP), JEDEC MO-118, 0.300" Wide
Package Number MS56A**

Physical Dimensions inches (millimeters) unless otherwise noted (Continued)

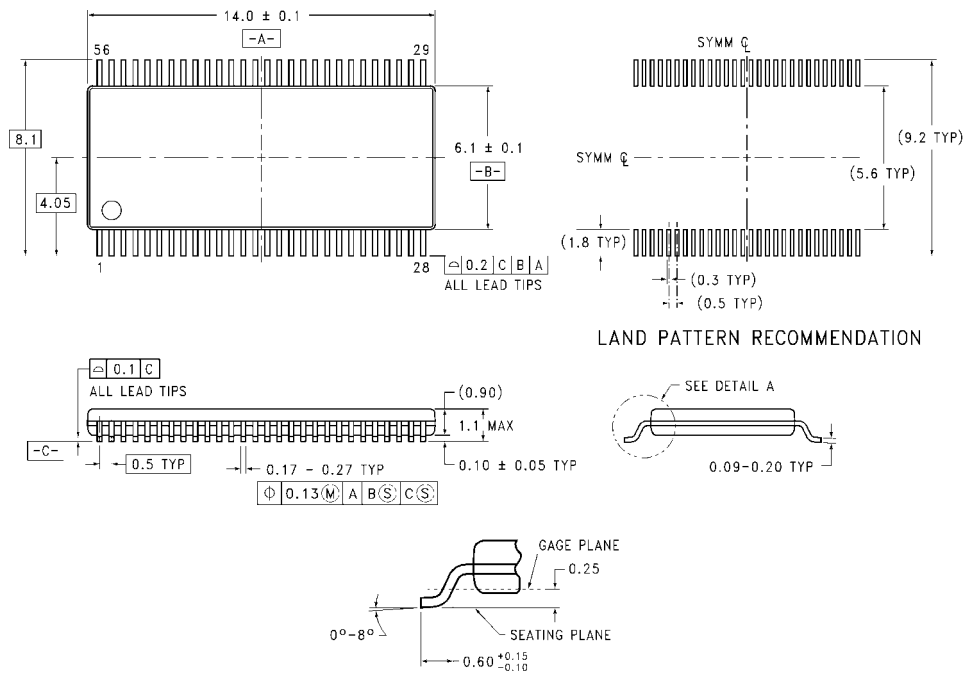

**56-Lead Thin Shrink Small Outline Package (TSSOP), JEDEC MO-153, 6.1mm Wide
Package Number MTD56**

MTD56 (REV 9)

LIFE SUPPORT POLICY

FAIRCHILD'S PRODUCTS ARE NOT AUTHORIZED FOR USE AS CRITICAL COMPONENTS IN LIFE SUPPORT DEVICES OR SYSTEMS WITHOUT THE EXPRESS WRITTEN APPROVAL OF THE PRESIDENT OF FAIRCHILD SEMICONDUCTOR CORPORATION. As used herein:

1. Life support devices or systems are devices or systems which, (a) are intended for surgical implant into the body, or (b) support or sustain life, and (c) whose failure to perform when properly used in accordance with instructions for use provided in the labeling, can be reasonably expected to result in a significant injury to the user.
2. A critical component in any component of a life support device or system whose failure to perform can be reasonably expected to cause the failure of the life support device or system, or to affect its safety or effectiveness.

www.fairchildsemi.com