

## 74ACT1284 IEEE 1284 Transceiver

### General Description

The 74ACT1284 contains four non-inverting bidirectional buffers and three non-inverting buffers with open Drain outputs and high drive capability on the B Ports. It is intended to provide a standard signaling method for a bi-direction parallel peripheral in an Extended Capabilities Port mode (ECP).

The HD (active HIGH) input pin enables the B Ports to switch from open Drain to a high drive totem pole output, capable of sourcing 14 mA on all seven buffers. The DIR input determines the direction of data flow on the bidirectional buffers. DIR (active HIGH) enables data flow from A Ports to B Ports. DIR (active LOW) enables data flow from B Ports to A Ports.

### Features

- TTL-compatible inputs
- A Ports have standard 4 mA totem pole outputs
- Typical input hysteresis of 0.5V
- B Port high drive source/sink capability of 14 mA
- Bidirectional non-inverting buffers
- Supports IEEE P1284 Level 1 and Level 2 signaling standards for bidirectional parallel communications between personal computers and printing peripherals
- B Port outputs in High Impedance mode during power down
- Guaranteed 4000V minimum ESD protection

### Ordering Code:

Order Number	Package Number	Package Description
74ACT1284SC	M20B	20-Lead Small Outline Integrated Circuit (SOIC), JEDEC MS-013, 0.300 Wide
74ACT1284MSA	MSA20	20-Lead Shrink Small Outline Package (SSOP), EIAJ TYPE II, 5.3mm Wide
74ACT1284MTC	MTC20	20-Lead Thin Shrink Small Outline Package (TSSOP), JEDEC MO-153, 4.4mm Wide

Device also available in Tape and Reel. Specify by appending suffix letter "X" to the ordering code.

### Logic Symbol

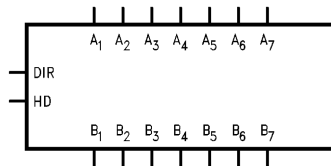

### Connection Diagram

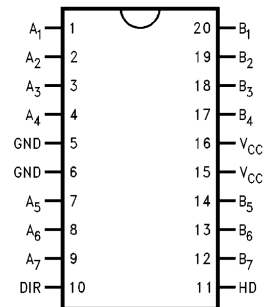

### Pin Descriptions

Pin Names	Description
HD	High Drive Enable input (Active HIGH)
DIR	Direction Control Input
A <sub>1</sub> - A <sub>4</sub>	Side A Inputs or Outputs
B <sub>1</sub> - B <sub>4</sub>	Side B Inputs or Outputs
A <sub>5</sub> - A <sub>7</sub>	Side A Inputs
B <sub>5</sub> - B <sub>7</sub>	Side B Outputs

FACT™ is a trademark of Fairchild Semiconductor Corporation.

**Truth Table**

Inputs		Outputs
DIR	HD	
L	L	B <sub>1</sub> - B <sub>4</sub> Data to A <sub>1</sub> - A <sub>4</sub> , and A <sub>5</sub> - A <sub>7</sub> Data to B <sub>5</sub> - B <sub>7</sub> (Note 1)
L	H	B <sub>1</sub> - B <sub>4</sub> Data to A <sub>1</sub> - A <sub>4</sub> , and A <sub>5</sub> - A <sub>7</sub> Data to B <sub>5</sub> - B <sub>7</sub>
H	L	A <sub>1</sub> - A <sub>7</sub> Data to B <sub>1</sub> - B <sub>7</sub> (Note 2)
H	H	A <sub>1</sub> - A <sub>7</sub> Data to B <sub>1</sub> - B <sub>7</sub>

Note 1: B<sub>5</sub> - B<sub>7</sub> Open Drain Outputs

Note 2: B<sub>1</sub> - B<sub>7</sub> Open Drain Outputs

**Logic Diagram**

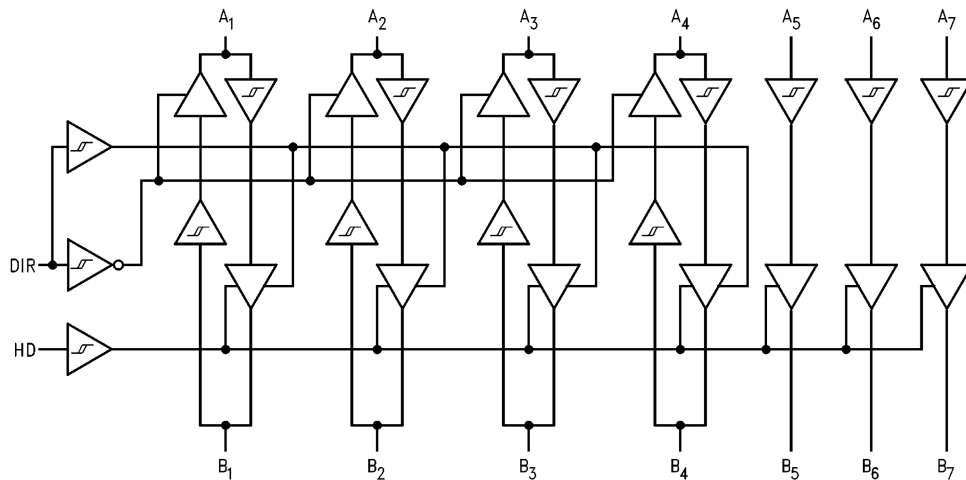

**Absolute Maximum Ratings**(Note 3)

(Note 4)

Supply Voltage ( $V_{CC}$ )	-0.5V to +7.0V
DC Input Diode Current ( $I_{IK}$ )	
$V_I = -0.5V$	-20 mA
$V_I = V_{CC} + 0.5V$	+20 mA
DC Input Voltage ( $V_I$ ) A Side	-0.5V to $V_{CC} + 0.5V$
DC Input Voltage ( $V_I$ ) B Side	-2V to +7V
DC Output Diode Current ( $I_{OK}$ )	
$V_O = -0.5V$	-20 mA
$V_O = V_{CC} + 0.5V$	+20 mA
DC Output Voltage ( $V_O$ ) A Side	-0.5V to $V_{CC} + 0.5V$
DC Output Voltage ( $V_O$ ) B Side	-2V to +7V
DC Output Source or Sink Current ( $I_O$ )	$\pm 50$ mA
DC $V_{CC}$ or Ground Current per Output Pin ( $I_{CC}$ or $I_{GND}$ )	$\pm 50$ mA
Storage Temperature ( $T_{STG}$ )	-65°C to +150°C

**Recommended Operating Conditions**

Supply Voltage ( $V_{CC}$ )	4.7V to 5.5V
Input Voltage ( $V_I$ )	0V to $V_{CC}$
Output Voltage ( $V_O$ )	0V to $V_{CC}$
Operating Temperature ( $T_A$ )	-40°C to +85°C

**Note 3:** Absolute maximum ratings are those values beyond which damage to the device may occur. The databook specifications should be met, without exception, to ensure that the system design is reliable over its power supply, temperature, and output/input loading variables. Fairchild does not recommend operation of FACT™ circuits outside databook specifications.

**Note 4:** Either voltage limit or current limit is sufficient to protect inputs.

**DC Electrical Characteristics**

Symbol	Parameter	$V_{CC}$ (V)	Guaranteed Limits			Units	Conditions
			$T_A = +25^\circ\text{C}$	$T_A = 0^\circ\text{C to } +70^\circ\text{C}$	$T_A = -40^\circ\text{C to } +85^\circ\text{C}$		
$V_{IH}$	Minimum HIGH Level Input Voltage	4.7	2.0	2.0	2.0	V	Recognized High Signal
		5.5	2.0	2.0	2.0		
$V_{IL}$	Maximum LOW Level Input Voltage	4.7	0.8	0.8	0.8	V	Recognized Low Signal
		5.5	0.8	0.8	0.8		
$V_{OH}$	Minimum HIGH Level Output Voltage	4.7	4.5	4.5	4.5	V	$I_{OUT} = -50 \mu\text{A}$ ( $A_n$ ) $V_{IN} = V_{IL}$ or $V_{IH}$ (Note 5) $I_{OH} = -4 \text{ mA}$ ( $A_n$ )
		4.7	3.7	3.7	3.7		
		4.7	2.4	2.4	2.4		
$V_{OL}$	Maximum LOW Level Output Voltage	4.7	0.2	0.2	0.2	V	$I_{OUT} = 50 \mu\text{A}$ ( $A_n$ ) $V_{IN} = V_{IL}$ or $V_{IH}$ (Note 5) $I_{OH} = 4 \text{ mA}$ ( $A_n$ )
		4.7	0.4	0.4	0.4		
$I_{IN}$	Maximum Input Leakage Current	5.5		$\pm 0.1$	$\pm 1.0$	$\mu\text{A}$	$V_I = V_{CC}$ , GND (DIR, A5, A6, A7, HD)
$I_{OCT}$	Maximum $I_{CC}$ /Input	5.5		1.5	1.5	mA	$V_I = V_{CC} - 2.1V$
$I_{CC}$	Maximum Quiescent Supply Current	5.5	400	400	500	$\mu\text{A}$	$V_{IN} = V_{CC}$ or GND
$I_{OZ}$	Maximum Output Leakage Current	5.5	$\pm 20$	$\pm 20$	$\pm 20$	$\mu\text{A}$	$V_O = V_{CC}$ , GND
$I_{OFF}$	Maximum B-Side Power Down Leakage Current	0.0	100	100	100	$\mu\text{A}$	$V_{OUT} = 5.25V$
$\Delta V_T$	Input Hysteresis	5.0	0.4	0.4	0.35	V	$V_T + - V_T -$
$R_D$	Maximum Output Impedance	5.0	22	22	24	$\Omega$	$B_n$ (Note 6)
	Minimum Output Impedance	5.0	8	8	6	$\Omega$	$B_n$ (Note 6)

**Note 5:** All outputs loaded; thresholds on input associated with output under test.

**Note 6:** This parameter is guaranteed but not tested, characterized only:  $R_D$  is the measure of the B-Side output impedance with the output in the HIGH state.

## AC Electrical Characteristics

Symbol	Parameter	$T_A = +25^\circ\text{C}$		$T_A = 0^\circ\text{C to } +70^\circ\text{C}$		$T_A = -40^\circ\text{C to } +85^\circ\text{C}$		Units	Figure Number
		$V_{CC} = 4.7\text{V} - 5.5\text{V}$		$V_{CC} = 4.7\text{V} - 5.5\text{V}$		$V_{CC} = 4.7\text{V} - 5.5\text{V}$			
		Min	Max	Min	Max	Min	Max		
$t_{PHL}$	$A_1 - A_7$ to $B_1 - B_7$	2.0	20.0	2.0	20.0	2.0	24.0	ns	Figure 1
$t_{PLH}$	$A_1 - A_7$ to $B_1 - B_7$	2.0	20.0	2.0	20.0	2.0	24.0	ns	Figure 2
$t_{PHL}$	$B_1 - B_4$ to $A_1 - A_4$	2.0	20.0	2.0	20.0	2.0	24.0	ns	Figure 3
$t_{PLH}$	$B_1 - B_4$ to $A_1 - A_4$	2.0	20.0	2.0	20.0	2.0	24.0	ns	Figure 3
$t_{pEnable}$	Output Enable Time HD to $B_1 - B_7$	2.0	20.0	2.0	20.0	2.0	24.0	ns	Figure 2
$t_{pDisable}$	Output Disable Time HD to $B_1 - B_7$	2.0	20.0	2.0	20.0	2.0	24.0	ns	Figure 2
$t_{SKEW}$	Output Slew Rate								Figure 1
$t_{PLH}$	$B_1 - B_7$	0.05	0.40	0.05	0.40	0.05	0.40	V/ns	Figure 2
$t_{PHL}$	$B_1 - B_7$								
$t_r, t_f$	$t_{RISE}$ and $t_{FALL}$ $B_1 - B_7$ (Note 7)		120		120		120	ns	Figure 4 (Note 8)

**Note 7:** Open Drain

**Note 8:** This parameter is guaranteed but not tested, characterized only.

**Note:** Pulse Generator for all pulses; Rate  $\leq 1.0$  MHz;  $A_O \leq 50\Omega$ ;  $t_f \leq 2.5$  ns,  $t_r \leq 2.5$  ns.

## Capacitance

Symbol	Parameter	Typ	Units	Conditions
$C_{IN}$	Input Capacitance	4.0	pF	$V_{CC} = \text{OPEN (HD, DIR } A_5 - A_7)$
$C_{I/O}$	I/O Pin Capacitance	12.0	pF	$V_{CC} = 5.0\text{V}$

### AC Loading and Waveforms

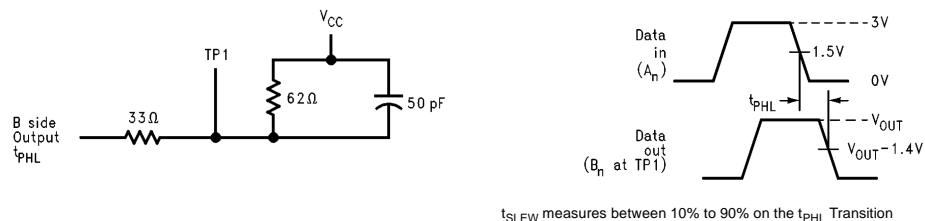

FIGURE 1. A to B Direction Test Load and Waveforms

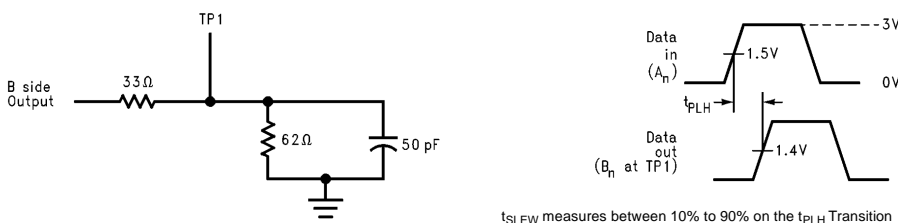

FIGURE 2. B Output Test Load and Waveforms



FIGURE 3. B to A Direction Test Load and Waveforms for Outputs A<sub>1</sub> - A<sub>4</sub>



FIGURE 4. A to B Direction Test Load and Waveforms for Open Drain B<sub>1</sub> - B<sub>7</sub>



**Physical Dimensions** inches (millimeters) unless otherwise noted (Continued)

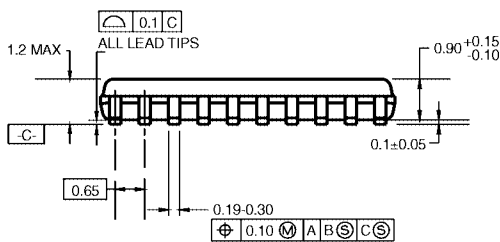
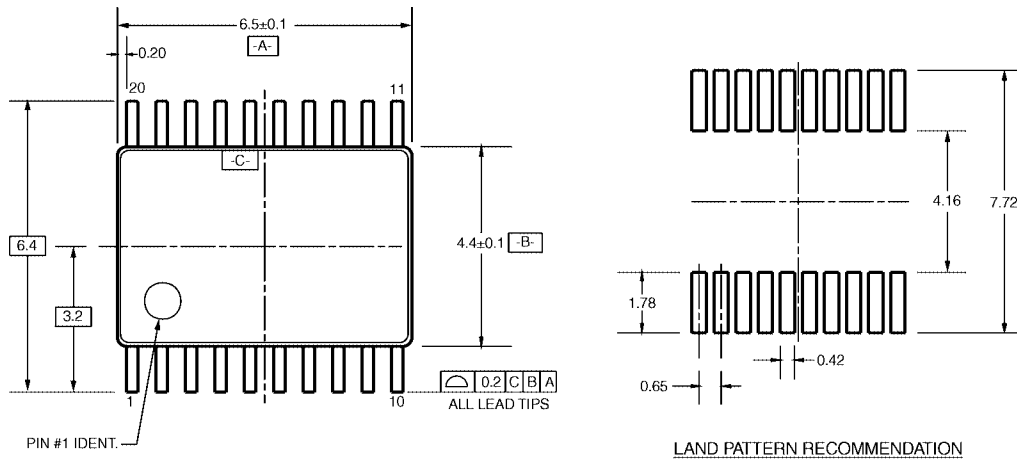

DIMENSIONS ARE IN MILLIMETERS

**NOTES:**

- A. CONFORMS TO JEDEC REGISTRATION MO-153, VARIATION AC, REF NOTE 6, DATE 7/93.
- B. DIMENSIONS ARE IN MILLIMETERS.
- C. DIMENSIONS ARE EXCLUSIVE OF BURRS, MOLD FLASH, AND TIE BAR EXTRUSIONS.
- D. DIMENSIONS AND TOLERANCES PER ANSI Y14.5M, 1982.

MTC20RevD1

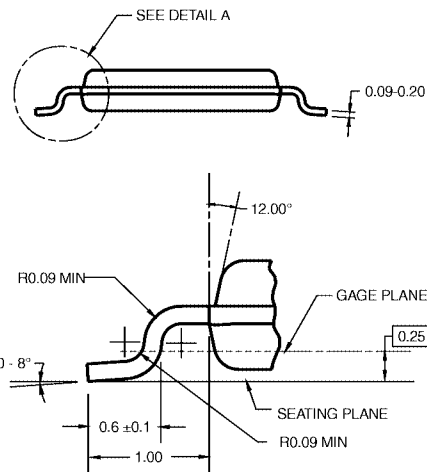

**DETAIL A**

**20-Lead Thin Shrink Small Outline Package (TSSOP), JEDEC MO-153, 4.4mm Wide  
Package Number MTC20**

Fairchild does not assume any responsibility for use of any circuitry described, no circuit patent licenses are implied and Fairchild reserves the right at any time without notice to change said circuitry and specifications.

**LIFE SUPPORT POLICY**

FAIRCHILD'S PRODUCTS ARE NOT AUTHORIZED FOR USE AS CRITICAL COMPONENTS IN LIFE SUPPORT DEVICES OR SYSTEMS WITHOUT THE EXPRESS WRITTEN APPROVAL OF THE PRESIDENT OF FAIRCHILD SEMICONDUCTOR CORPORATION. As used herein:

1. Life support devices or systems are devices or systems which, (a) are intended for surgical implant into the body, or (b) support or sustain life, and (c) whose failure to perform when properly used in accordance with instructions for use provided in the labeling, can be reasonably expected to result in a significant injury to the user.
2. A critical component in any component of a life support device or system whose failure to perform can be reasonably expected to cause the failure of the life support device or system, or to affect its safety or effectiveness.

[www.fairchildsemi.com](http://www.fairchildsemi.com)