

74F401 CRC Generator/Checker

General Description

The 74F401 Cycle Redundancy Check (CRC) Generator/Checker provides an advanced tool for implementing the most widely used error detection scheme in serial digital data handling systems. A 3-bit control input selects one-of-eight generator polynomials. The list of polynomials includes CRC-16 and CRC-CCITT as well as their reciprocals (reverse polynomials). Automatic right justification is incorporated for polynomials of degree less than 16. Separate clear and preset inputs are provided for floppy disk and other applications. The Error output indicates whether or not a transmission error has occurred. Another control input inhibits feedback during check word transmission. The 74F401 is fully compatible with all TTL families.

Features

- Eight selectable polynomials
- Error indicator
- Separate preset and clear controls
- Automatic right justification
- Fully compatible with all TTL logic families
- 14-pin package
- 9401 equivalent
- Typical applications:
 - Floppy and other disk storage systems
 - Digital cassette and cartridge systems
 - Data communication systems

Ordering Code:

Order Number	Package Number	Package Description
74F401SC	M14A	14-Lead Small Outline Integrated Circuit (SOIC), JEDEC MS-120, 0.150 Narrow
74F401PC	N14A	14-Lead Plastic Dual-In-Line Package (PDIP), JEDEC MS-001, 0.300 Wide

Devices also available in Tape and Reel. Specify by appending the suffix letter "X" to the ordering code.

Logic Symbol

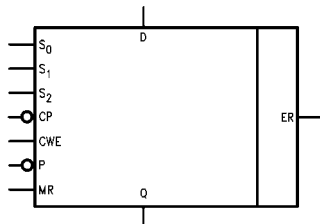

Connection Diagram

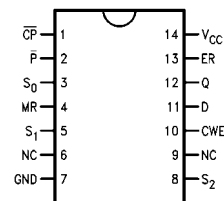

Unit Loading/Fan Out

Pin Names	Description	U.L.	
		HIGH/LOW	Input I_{IH}/I_{IL} Output I_{OH}/I_{OL}
S_0 - S_2	Polynomial Select Inputs	1.0/1.0	20 μ A/-0.6 mA
D	Data Input	1.0/1.0	20 μ A/-0.6 mA
\overline{CP}	Clock Input (Operates on HIGH-to-LOW Transition)	1.0/1.0	20 μ A/-0.6 mA
CWE	Check Word Enable Input	1.0/1.0	20 μ A/-0.6 mA
\overline{P}	Preset (Active LOW) Input	1.0/1.0	20 μ A/-0.6 mA
MR	Master Reset (Active HIGH) Input	1.0/1.0	20 μ A/-0.6 mA
Q	Data Output	50/33.3	-1 mA/20 mA
ER	Error Output	50/33.3	-1 mA/20 mA

Functional Description

The 74F401 is a 16-bit programmable device which operates on serial data streams and provides a means of detecting transmission errors. Cyclic encoding and decoding schemes for error detection are based on polynomial manipulation in modulo arithmetic. For encoding, the data stream (message polynomial) is divided by a selected polynomial. This division results in a remainder which is appended to the message as check bits. For error checking, the bit stream containing both data and check bits is divided by the same selected polynomial. If there are no detectable errors, this division results in a zero remainder. Although it is possible to choose many generating polynomials of a given degree, standards exist that specify a small number of useful polynomials. The 74F401 implements the polynomials listed in Table 1 by applying the appropriate logic levels to the select pins S_0 , S_1 and S_2 .

The 74F401 consists of a 16-bit register, a Read Only Memory (ROM) and associated control circuitry as shown in the block diagram. The polynomial control code presented at inputs S_0 , S_1 and S_2 is decoded by the ROM, selecting the desired polynomial by establishing shift mode operation on the register with Exclusive OR gates at appropriate inputs. To generate the check bits, the data stream is entered via the Data inputs (D), using the HIGH-to-LOW

transition of the Clock input (\overline{CP}). This data is gated with the most significant output (Q) of the register, and controls the Exclusive OR gates Figure 1. The Check Word Enable (CWE) must be held HIGH while the data is being entered. After the last data bit is entered, the CWE is brought LOW and the check bits are shifted out of the register and appended to the data bits using external gating Figure 2.

To check an incoming message for errors, both the data and check bits are entered through the D input with the CWE input held HIGH. The 74F401 is not in the data path, but only monitors the message. The Error Output becomes valid after the last check bit has been entered into the 74F401 by a HIGH-to-LOW transition of \overline{CP} . If no detectable errors have occurred during the data transmission, the resultant internal register bits are all LOW and the Error Output (ER) is LOW. If a detectable error has occurred, ER is HIGH.

A HIGH on the Master Reset input (MR) asynchronously clears the register. A LOW on the Preset input (\overline{P}) asynchronously sets the entire register if the control code inputs specify a 16-bit polynomial; in the case of 12- or 8-bit check polynomials only the most significant 12 or 8 register bits are set and the remaining bits are cleared.

TABLE 1.

Select Code			Polynomial	Remarks
S_2	S_1	S_0		
L	L	L	$X^{16} + X^{15} + X^2 + 1$	CRC-16
L	L	H	$X^{16} + X^{14} + X + 1$	CRC-16 REVERSE
L	H	L	$X^{16} + X^{15} + X^{13} + X^7 + X^4 + X^2 + X^1 + 1$	
L	H	H	$X^{12} + X^{11} + X^3 + X^2 + X + 1$	CRC-12
H	L	L	$X^8 + X^7 + X^5 + X^4 + X + 1$	
H	L	H	$X^8 + 1$	LRC-8
H	H	L	$X^{16} + X^{12} + X^5 + 1$	CRC-CCITT
H	H	H	$X^{16} + X^{11} + X^4 + 1$	CRC-CCITT REVERSE

Block Diagram

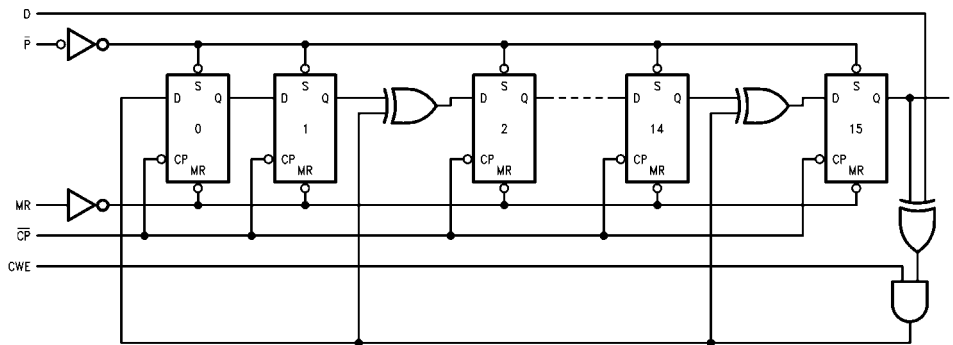
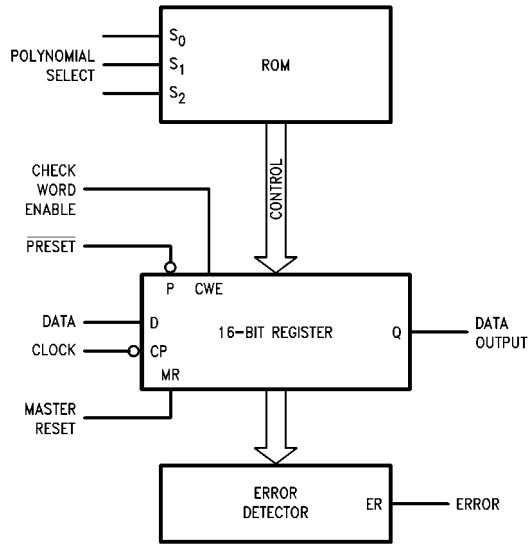

FIGURE 1. Equivalent Circuit for $X^{16} + X^{15} + X^2 + 1$

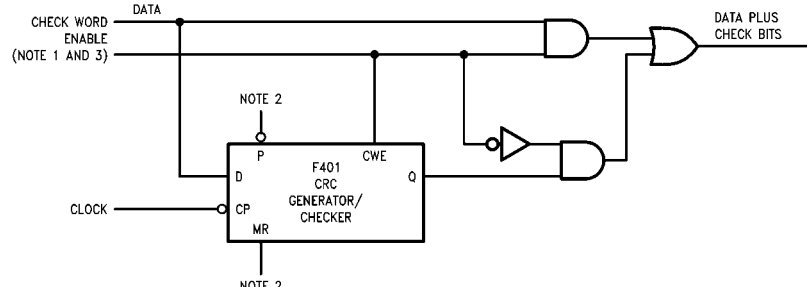

FIGURE 2. Check Word Generation

Note 1: Check word Enable is HIGH while data is being clocked, LOW while transmission of check bits.

Note 2: 74F401 must be reset or preset before each computation.

Note 3: CRC check bits are generated and appended to data bits.

Absolute Maximum Ratings (Note 4)

Storage Temperature	-65°C to +150°C
Ambient Temperature under Bias	-55°C to +125°C
Junction Temperature under Bias	-55°C to +150°C
V _{CC} Pin Potential to Ground Pin	-0.5V to +7.0V
Input Voltage (Note 5)	-0.5V to +7.0V
Input Current (Note 5)	-30 mA to +5.0 mA
Voltage Applied to Output in HIGH State (with V _{CC} = 0V)	
Standard Output	-0.5V to V _{CC}
3-STATE Output	-0.5V to +5.5V
Current Applied to Output in LOW State (Max)	twice the rated I _{OL} (mA)

Recommended Operating Conditions

Free Air Ambient Temperature	0°C to +70°C
Supply Voltage	+4.5V to +5.5V

Note 4: Absolute maximum ratings are values beyond which the device may be damaged or have its useful life impaired. Functional operation under these conditions is not implied.

Note 5: Either voltage limit or current limit is sufficient to protect inputs.

DC Electrical Characteristics

Symbol	Parameter	Min	Typ	Max	Units	V _{CC}	Conditions
V _{IH}	Input HIGH Voltage	2.0			V		Recognized as a HIGH Signal
V _{IL}	Input LOW Voltage			0.8	V		Recognized as a LOW Signal
V _{CD}	Input Clamp Diode Voltage			-1.2	V	Min	I _{IN} = -18 mA
V _{OH}	Output HIGH Voltage	10% V _{CC}	2.5		V	Min	I _{OH} = -1 mA
		5% V _{CC}	2.7				I _{OH} = -1 mA
V _{OL}	Output LOW Voltage	10% V _{CC}		0.5	V	Min	I _{OL} = 20 mA
I _{IH}	Input HIGH Current			5.0	μA	Max	V _{IN} = 2.7V
I _{BVI}	Input HIGH Current Breakdown Test			7.0	μA	Max	V _{IN} = 7.0V
I _{CEX}	Output HIGH Leakage Current			50	μA	Max	V _{OUT} = V _{CC}
V _{ID}	Input Leakage Test	4.75			V	0.0	I _{ID} = 1.9 μA All Other Pins Grounded
I _{OD}	Output Leakage Circuit Current			3.75	μA	0.0	V _{IOD} = 150 mV All Other Pins Grounded
I _{IL}	Input LOW Current			-0.6	mA	Max	V _{IN} = 0.5V
I _{OS}	Output Short-Circuit Current	-60		-150	mA	Max	V _{OUT} = 0V
I _{CCH}	Power Supply Current		70	105	mA	Max	V _O = HIGH

AC Electrical Characteristics							
Symbol	Parameter	$T_A = +25^\circ\text{C}$ $V_{CC} = +5.0\text{V}$ $C_L = 50\text{ pF}$			$T_A = 0^\circ\text{C to } +70^\circ\text{C}$ $V_{CC} = +5.0\text{V}$ $C_L = 50\text{ pF}$		Units
		Min	Typ	Max	Min	Max	
f_{MAX}	Maximum Clock Frequency	100			85		MHz
t_{PLH}	Propagation Delay	4.5		11.5	4.5	13.5	ns
t_{PHL}	$\overline{\text{CP}}$ to Q	4.0		10.0	4.0	11.0	
t_{PHL}	Propagation Delay MR to Q	3.0		7.5	3.0	8.0	ns
t_{PLH}	Propagation Delay $\overline{\text{P}}$ to Q	3.0		8.5	3.0	9.5	ns
t_{PHL}	Propagation Delay MR to ER	3.5		11.0	3.5	12.0	ns
t_{PLH}	Propagation Delay $\overline{\text{P}}$ to ER	3.0		8.5	3.0	10.0	ns
t_{PLH}	Propagation Delay	5.0		13.0	5.0	14.5	ns
t_{PHL}	$\overline{\text{CP}}$ to ER	4.5		11.5	4.5	12.5	
AC Operating Requirements							
Symbol	Parameter	$T_A = +25^\circ\text{C}$ $V_{CC} = +5.0\text{V}$		$T_A = 0^\circ\text{C to } +70^\circ\text{C}$ $V_{CC} = +5.0\text{V}$		Units	
		Min	Max	Min	Max		
$t_{\text{S}}(\text{H})$	Set-up Time, HIGH or LOW	5.0		5.5		ns	
$t_{\text{S}}(\text{L})$	D to $\overline{\text{CP}}$	5.0		5.5			
$t_{\text{S}}(\text{H})$	Set-up Time, HIGH or LOW	4.0		4.5		ns	
$t_{\text{S}}(\text{L})$	CWE to $\overline{\text{CP}}$	4.0		4.5			
$t_{\text{H}}(\text{H})$	Hold Time, HIGH or LOW	2.0		2.0		ns	
$t_{\text{H}}(\text{L})$	D and CWE to $\overline{\text{CP}}$	2.0		2.0			
$t_{\text{W}}(\text{L})$	$\overline{\text{P}}$ Pulse Width, LOW	7.0		8.0		ns	
$t_{\text{W}}(\text{H})$	Clock Pulse Width,	5.0		6.0		ns	
$t_{\text{W}}(\text{L})$	HIGH or LOW	5.0		6.0			
$t_{\text{W}}(\text{H})$	MR Pulse Width, HIGH	5.0		5.5		ns	
t_{REC}	Recovery Time MR to $\overline{\text{CP}}$	4.0		4.5		ns	
t_{REC}	Recovery Time $\overline{\text{P}}$ to $\overline{\text{CP}}$	2.0		2.0		ns	

Physical Dimensions inches (millimeters) unless otherwise noted

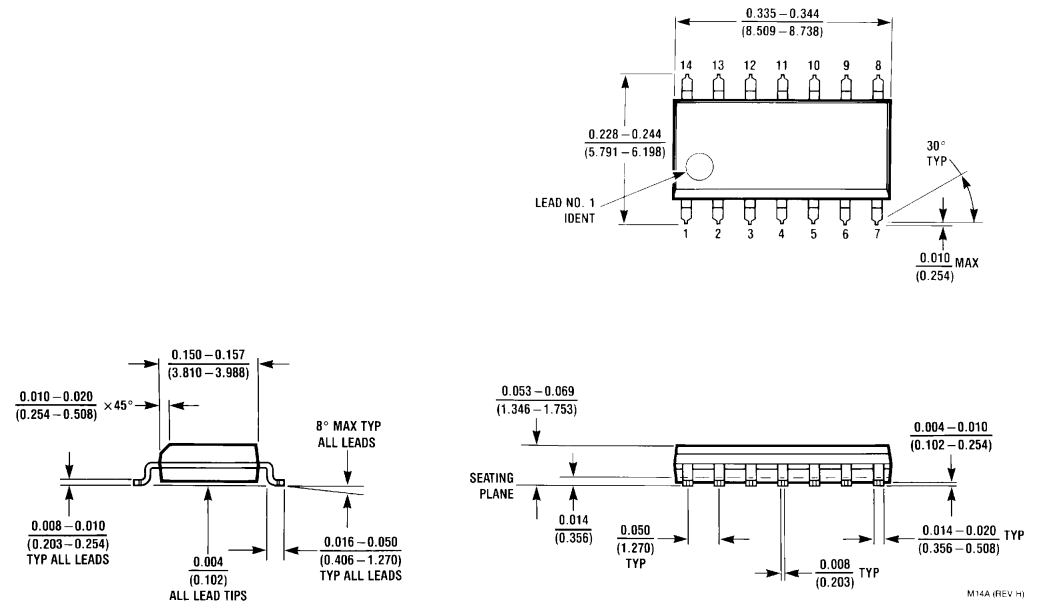

**14-Lead Small Outline Integrated Circuit (SOIC), JEDEC MS-120, 0.150 Narrow
Package Number M14A**

Physical Dimensions inches (millimeters) unless otherwise noted (Continued)

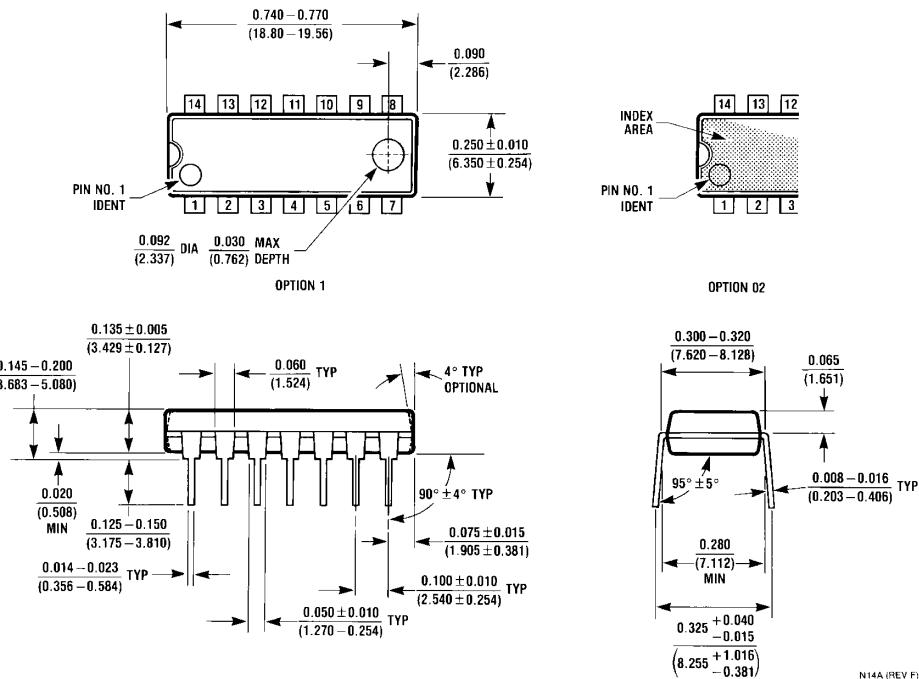

N14A (REV F)

Fairchild does not assume any responsibility for use of any circuitry described, no circuit patent licenses are implied and Fairchild reserves the right at any time without notice to change said circuitry and specifications.

LIFE SUPPORT POLICY

FAIRCHILD'S PRODUCTS ARE NOT AUTHORIZED FOR USE AS CRITICAL COMPONENTS IN LIFE SUPPORT DEVICES OR SYSTEMS WITHOUT THE EXPRESS WRITTEN APPROVAL OF THE PRESIDENT OF FAIRCHILD SEMICONDUCTOR CORPORATION. As used herein:

1. Life support devices or systems are devices or systems which, (a) are intended for surgical implant into the body, or (b) support or sustain life, and (c) whose failure to perform when properly used in accordance with instructions for use provided in the labeling, can be reasonably expected to result in a significant injury to the user.
2. A critical component in any component of a life support device or system whose failure to perform can be reasonably expected to cause the failure of the life support device or system, or to affect its safety or effectiveness.

www.fairchildsemi.com