

# 74F552

## Octal Registered Transceiver with Parity and Flags

### General Description

The 74F552 octal transceiver contains two 8-bit registers for temporary storage of data flowing in either direction. Each register has its own clock pulse and clock enable input as well as a flag flip-flop that is set automatically as the register is loaded. The flag output will be reset when the output enable returns to HIGH after reading the output port. Each register has a separate output enable control for its 3-STATE buffer. The separate Clocks, Flags, and Enables provide considerable flexibility as I/O ports for demand-response data transfer. When data is transferred from the A Port to the B Port, a parity bit is generated. On the other hand, when data is transferred from the B Port to the A Port, the parity of input data on B<sub>0</sub>-B<sub>7</sub> is checked.

### Features

- 8-Bit bidirectional I/O Port with handshake
- Register status flag flip-flops
- Separate clock enable and output enable
- Parity generation and parity check
- B-outputs sink 64 mA
- 3-STATE outputs

### Ordering Code:

Order Number	Package Number	Package Description
74F552SC	M28B	28-Lead Small Outline Integrated Circuit (SOIC), JEDEC MS-013, 0.300 Wide
74F552QC	V28A	28-Lead Plastic Lead Chip Carrier (PLCC), JEDEC MO-047, 0.450 Square

Devices also available in Tape and Reel. Specify by appending the suffix letter "X" to the ordering code.

### Logic Symbols

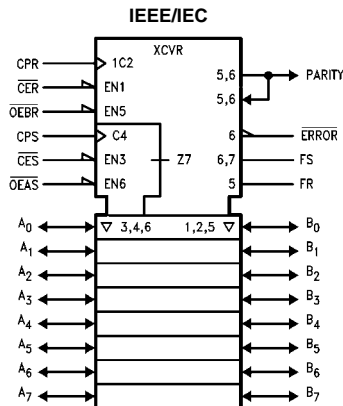
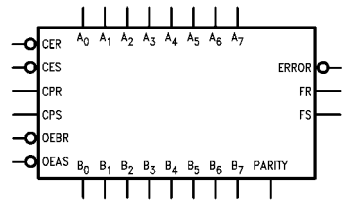

### Connection Diagram

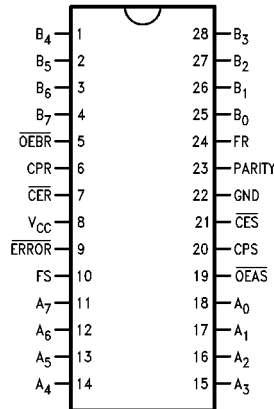

## Unit Loading/Fan Out

Pin Names	Description	U.L.	
		HIGH/LOW	Input $I_{IH}/I_{IL}$ Output $I_{OH}/I_{OL}$
$A_0-A_7$	A-to-B Port Data Inputs or B-to-A 3-STATE	3.5/1.083 150/40 (33.3)	70 $\mu$ A/-0.65 mA -3 mA/24 mA (20 mA)
$B_0-B_7$	B-to-A Transceiver Inputs or A-to-B 3-STATE Output	3.5/1.083 600/106.6 (80)	70 $\mu$ A/-0.65 mA -12 mA/64 mA (48 mA)
FR	B Port Flag Output	50/33.3	-1 mA/20 mA
FS	A Port Flag Output	50/33.3	-1 mA/20 mA
PARITY	Parity Bit Transceiver Input or Output	3.5/1.083 600/106.6 (50)	70 $\mu$ A/-0.65 mA -12 mA/64 mA (48 mA)
$\overline{\text{ERROR}}$	Parity Check Output (Active LOW)	50/33.3	-1 mA/20 mA
$\overline{\text{CER}}$	R Registers Clock Enable Input (Active LOW)	1.0/1.0	20 $\mu$ A/-0.6 mA
$\overline{\text{CES}}$	S Registers Clock Enable Input (Active LOW)	1.0/1.0	20 $\mu$ A/-0.6 mA
CPR	R Registers Clock Pulse Input (Active Rising Edge)	1.0/1.0	20 $\mu$ A/-0.6 mA
CPS	S Registers Clock Pulse Input (Active Rising Edge)	1.0/1.0	20 $\mu$ A/-0.6 mA
$\overline{\text{OEBR}}$	B Port and PARITY Output Enable (Active LOW) and Clear FR Input (Active Rising Edge)	1.0/2.0	20 $\mu$ A/-1.2 mA
$\overline{\text{OEAS}}$	A Port Output Enable (Active LOW) and Clear FS Input (Active Rising Edge)	1.0/2.0	20 $\mu$ A/-1.2 mA

## Functional Description

Data applied to the A-inputs are entered and stored in the R register on the rising edge of the CPR Clock Pulse, provided that the Clock Enable ( $\overline{\text{CER}}$ ) is LOW; simultaneously, the status flip-flop is set and the flag (FR) output goes HIGH. As the Clock Enable ( $\overline{\text{CER}}$ ) returns to HIGH, the data will be held in the R register. These data entered from the A-inputs will appear at the B Port I/O pins after the Output Enable ( $\overline{\text{OEBR}}$ ) has gone LOW. When  $\overline{\text{OEBR}}$  is LOW, a parity bit appears at the PARITY pin, which will be set HIGH when there is an even number of 1s or all 0s at the Q outputs of the R register. After the data is assimilated, the receiving system clears the flag FR by changing the signal at the  $\overline{\text{OEBR}}$  pin from LOW-to-HIGH.

Data flow from B-to-A proceeds in the same manner described for A-to-B flow. A LOW at the  $\overline{\text{CES}}$  pin and a LOW-to-HIGH transition at CPS pin enters the B-input data and the parity-input data into the S registers and the parity register respectively and set the flag output FS to HIGH. A LOW signal at the  $\overline{\text{OEAS}}$  pin enables the A Port I/O pins and a LOW-to-HIGH transition of the  $\overline{\text{OEAS}}$  signal clears the FS flag. When  $\overline{\text{OEAS}}$  is LOW, the parity check output ERROR will be HIGH if there is an odd number of 1s at the Q outputs of the S registers and the parity register. The flag FS can be cleared by a LOW-to-HIGH transition of the  $\overline{\text{OEAS}}$  signal.

## Register Function Table

(Applies to R or S Register)

Inputs			Internal Q	Function
D	CP	$\overline{\text{CE}}$		
X	X	H	NC	Hold Data
L	↗	L	L	Load Data
H	↗	L	H	
X	↑	L	NC	Keep Old Data

H = HIGH Voltage Level  
L = LOW Voltage Level  
X = Immaterial

↗ = LOW-to-HIGH Transition  
↑ = Not LOW-to-HIGH Transition  
NC = No Change

## Flag Flip-Flop Function Table

(Applies to R or S Flag Flip-Flop)

Inputs			Flag Output	Function
$\overline{\text{CE}}$	CP	$\overline{\text{OE}}$		
H	X	↑	NC	Hold Flag
L	↗	↑	H	Set Flag
X	X	↗	L	Clear Flag

H = HIGH Voltage Level  
L = LOW Voltage Level  
X = Immaterial

↗ = LOW-to-HIGH Transition  
↑ = Not LOW-to-HIGH Transition  
NC = No Change

## Output Control

$\overline{\text{OE}}$	Internal Q	A or B Outputs	Function
H	X	Z	Disable Output
L	L	L	Enable Output
L	H	H	Enable Output

H = HIGH Voltage Level  
L = LOW Voltage Level

X = Immaterial  
Z = High Impedance

## Parity Generation Function

$\overline{\text{OEBR}}$	Number of HIGHS in the Q Outputs of the R Register	Parity Output
H	X	Z
L	0, 2, 4, 6, 8	H
L	1, 3, 5, 7	L

H = HIGH Voltage Level  
L = LOW Voltage Level

X = Immaterial  
Z = High Impedance

## Parity Check Function

$\overline{\text{OEAS}}$	Number of HIGHS in the Q Outputs of the S Register	Parity Input	ERROR Output
H	X	X	H
L	0, 2, 4, 6, 8	L	L
L	1, 3, 5, 7	L	H
L	0, 2, 4, 6, 8	H	H
L	1, 3, 5, 7	H	L

H = HIGH Voltage Level  
L = LOW Voltage Level  
X = Immaterial

Block Diagram

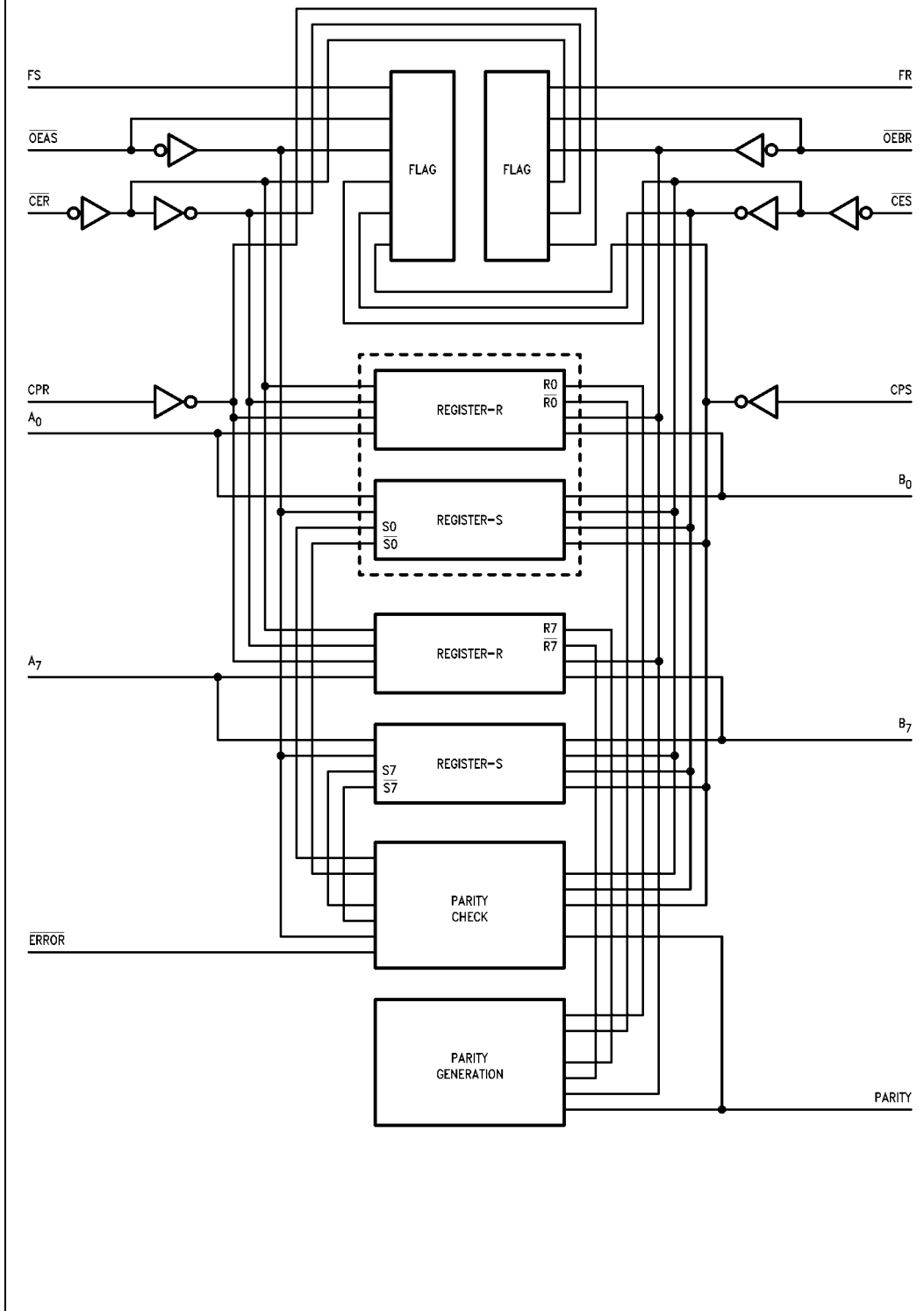

**Absolute Maximum Ratings**(Note 1)

Storage Temperature	-65°C to +150°C
Ambient Temperature under Bias	-55°C to +125°C
Junction Temperature under Bias	-55°C to +175°C
V <sub>CC</sub> Pin Potential to Ground Pin	-0.5V to +7.0V
Input Voltage (Note 2)	-0.5V to +7.0V
Input Current (Note 2)	-30 mA to +5.0 mA
Voltage Applied to Output in HIGH State (with V <sub>CC</sub> = 0V)	
Standard Output	-0.5V to V <sub>CC</sub>
3-STATE Output	-0.5V to +5.5V
Current Applied to Output in LOW State (Max)	twice the rated I <sub>OL</sub> (mA)

**Recommended Operating Conditions**

Free Air Ambient Temperature	0°C to +70°C
Supply Voltage	+4.5V to +5.5V

**Note 1:** Absolute maximum ratings are values beyond which the device may be damaged or have its useful life impaired. Functional operation under these conditions is not implied.

**Note 2:** Either voltage limit or current limit is sufficient to protect inputs.

**DC Electrical Characteristics**

Symbol	Parameter	Min	Typ	Max	Units	V <sub>CC</sub>	Conditions
V <sub>IH</sub>	Input HIGH Voltage	2.0			V		Recognized as a HIGH Signal
V <sub>IL</sub>	Input LOW Voltage			0.8	V		Recognized as a LOW Signal
V <sub>CD</sub>	Input Clamp Diode Voltage			-1.2	V	Min	I <sub>IN</sub> = -18 mA ( <u>CER</u> , <u>CES</u> , CPR, CPS, <u>OE<sub>BR</sub></u> , <u>OEAS</u> )
V <sub>OH</sub>	Output HIGH Voltage	10% V <sub>CC</sub> 2.5 10% V <sub>CC</sub> 2.4 10% V <sub>CC</sub> 2.0 5% V <sub>CC</sub> 2.7 5% V <sub>CC</sub> 2.7			V	Min	I <sub>OH</sub> = -1 mA (FR, FS, <u>ERROR</u> , A <sub>n</sub> ) I <sub>OH</sub> = -3 mA (A <sub>n</sub> , B <sub>n</sub> PARITY) I <sub>OH</sub> = -15 mA (B <sub>n</sub> , PARITY) I <sub>OH</sub> = -1 mA (FR, FS, <u>ERROR</u> , A <sub>n</sub> ) I <sub>OH</sub> = -3 mA (A <sub>n</sub> , B <sub>n</sub> , PARITY)
V <sub>OL</sub>	Output LOW Voltage	10% V <sub>CC</sub> 10% V <sub>CC</sub> 10% V <sub>CC</sub>		0.5 0.5 0.55	V	Min	I <sub>OL</sub> = 20 mA (FR, FS, <u>ERROR</u> ) I <sub>OL</sub> = 24 mA (A <sub>n</sub> ) I <sub>OL</sub> = 64 mA (B <sub>n</sub> , PARITY)
I <sub>IH</sub>	Input HIGH Current			5.0	μA	Max	V <sub>IN</sub> = 2.7V ( <u>CER</u> , <u>CES</u> , CPR, CPS, <u>OE<sub>BR</sub></u> , <u>OEAS</u> )
I <sub>BVI</sub>	Input HIGH Current Breakdown Test			7.0	μA	Max	V <sub>IN</sub> = 7.0V ( <u>CER</u> , <u>CES</u> , CPR, CPS, <u>OE<sub>BR</sub></u> , <u>OEAS</u> )
I <sub>BVIT</sub>	Input HIGH Current Breakdown (I/O)			0.5	mA	Max	V <sub>IN</sub> = 5.5V (A <sub>n</sub> , B <sub>n</sub> , PARITY)
I <sub>C<sub>EX</sub></sub>	Output HIGH Leakage Current			50	μA	Max	V <sub>OUT</sub> = V <sub>CC</sub> (FR, FS, <u>ERROR</u> , A <sub>n</sub> , B <sub>n</sub> , PARITY)
V <sub>ID</sub>	Input Leakage Test	4.75			V	0.0	I <sub>ID</sub> = 1.9 μA All other pins grounded
I <sub>OD</sub>	Output Leakage Circuit Current			3.75	μA	0.0	V <sub>I<sub>OD</sub></sub> = 150 mV All other pins grounded
I <sub>IL</sub>	Input LOW Current			-0.6 -1.2	mA	Max	V <sub>IN</sub> = 0.5V ( <u>CER</u> , <u>CES</u> , CPR, CPS) V <sub>IN</sub> = 0.5V ( <u>OE<sub>BR</sub></u> , <u>OEAS</u> )
I <sub>IH</sub> + I <sub>OZH</sub>	Output Leakage Current			70	μA	Max	V <sub>OUT</sub> = 2.7V (A <sub>n</sub> , B <sub>n</sub> , PARITY)
I <sub>IL</sub> + I <sub>OZL</sub>	Output Leakage Current			-650	μA	Max	V <sub>OUT</sub> = 0.5V (A <sub>n</sub> , B <sub>n</sub> , PARITY)
I <sub>OS</sub>	Output Short-Circuit Current	-60 -100		-175 -250	mA	Max	V <sub>OUT</sub> = 0V (FR, FS, <u>ERROR</u> , A <sub>n</sub> ) V <sub>OUT</sub> = 0V (B <sub>n</sub> , PARITY)
I <sub>ZZ</sub>	Bus Drainage Test			500	μA	0.0V	V <sub>OUT</sub> = 5.25V (A <sub>n</sub> , B <sub>n</sub> , PARITY)
I <sub>CC<sub>H</sub></sub>	Power Supply Current		100	150	mA	Max	V <sub>O</sub> = HIGH
I <sub>CC<sub>L</sub></sub>	Power Supply Current		100	150	mA	Max	V <sub>O</sub> = LOW
I <sub>CC<sub>Z</sub></sub>	Power Supply Current		110	165	mA	Max	V <sub>O</sub> = HIGH Z

AC Electrical Characteristics							
Symbol	Parameter	T <sub>A</sub> = +25°C V <sub>CC</sub> = +5.0V C <sub>L</sub> = 50 pF			T <sub>A</sub> = 0°C to +70°C V <sub>CC</sub> = +5.0V C <sub>L</sub> = 50 pF		Units
		Min	Typ	Max	Min	Max	
t <sub>PLH</sub>	Propagation Delay	3.5	6.0	8.0	3.0	9.0	ns
t <sub>PHL</sub>	CPS or CPR to A <sub>n</sub> or B <sub>n</sub>	4.0	7.0	9.5	3.5	10.5	
t <sub>PLH</sub>	Propagation Delay	3.0	5.5	7.5	2.5	8.5	ns
t <sub>PHL</sub>	Propagation Delay	3.5	6.0	8.0	3.0	9.0	ns
t <sub>PLH</sub>	Propagation Delay	8.0	14.0	18.0	7.0	20.0	ns
t <sub>PHL</sub>	CPR to Parity	8.5	14.5	18.5	7.5	20.5	
t <sub>PLH</sub>	Propagation Delay	8.0	13.5	17.5	7.0	19.5	ns
t <sub>PHL</sub>	CPS to ERROR	7.5	13.0	16.5	6.5	18.5	
t <sub>PLH</sub>	Propagation Delay	3.5	6.0	8.0	3.0	9.0	ns
t <sub>PHL</sub>	OEAS to ERROR	3.0	5.0	7.0	2.5	8.0	
t <sub>PZH</sub>	Enable Time OEAS	3.0	5.5	7.5	2.5	8.5	ns
t <sub>PZL</sub>	or OEBR to B <sub>n</sub> or A <sub>n</sub>	3.5	7.0	9.5	3.0	10.5	
t <sub>PHZ</sub>	Disable Time OEAS	3.0	6.5	8.5	2.5	9.5	ns
t <sub>PLZ</sub>	or OEBR to B <sub>n</sub> or A <sub>n</sub>	3.0	5.5	7.5	2.5	8.5	
t <sub>PZH</sub>	Enable Time	3.0	4.5	7.5	2.5	8.5	ns
t <sub>PZL</sub>	OEBR to Parity	3.5	6.0	9.5	3.0	10.5	
t <sub>PHZ</sub>	Disable Time	3.0	5.5	8.5	2.5	9.5	ns
t <sub>PLZ</sub>	OEBR to Parity	3.0	6.5	7.5	2.5	8.5	

AC Operating Requirements						
Symbol	Parameter	T <sub>A</sub> = +25°C V <sub>CC</sub> = +5.0V		T <sub>A</sub> = 0°C to +70°C V <sub>CC</sub> = +5.0V		Units
		Min	Max	Min	Max	
t <sub>S</sub> (H)	Setup Time, HIGH or LOW	7.5		8.5		ns
t <sub>S</sub> (L)	A <sub>n</sub> or B <sub>n</sub> or Parity to CPS or CPR	4.5		5.0		
t <sub>H</sub> (H)	Hold Time, HIGH or LOW	0		0		ns
t <sub>H</sub> (L)	A <sub>n</sub> or B <sub>n</sub> or Parity to CPS or CPR	0		0		
t <sub>S</sub> (H)	Setup, Time HIGH or LOW	6.0		7.0		ns
t <sub>S</sub> (L)	CES or CER to CPS or CPR	10.0		11.5		
t <sub>H</sub> (H)	Hold Time, HIGH or LOW	0		0		ns
t <sub>H</sub> (L)	CES or CER to CPS or CPR	0		0		
t <sub>W</sub> (H)	Pulse Width, HIGH or LOW	4.0		4.5		ns
t <sub>W</sub> (L)	CPS or CPR	6.0		7.0		

**Physical Dimensions** inches (millimeters) unless otherwise noted

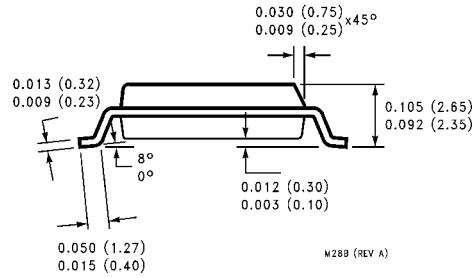
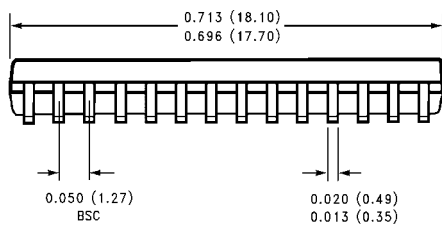
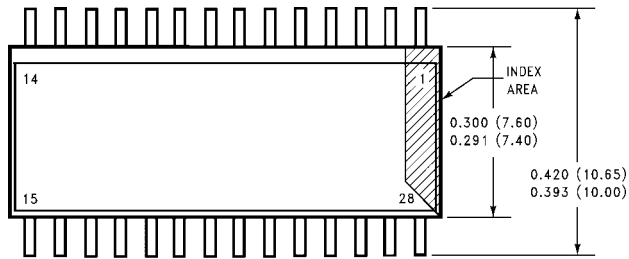

M289 (REV A)

**28-Lead Small Outline Integrated Circuit (SOIC), JEDEC MS-013, 0.300 Wide  
Package Number M28B**

**Physical Dimensions** inches (millimeters) unless otherwise noted (Continued)

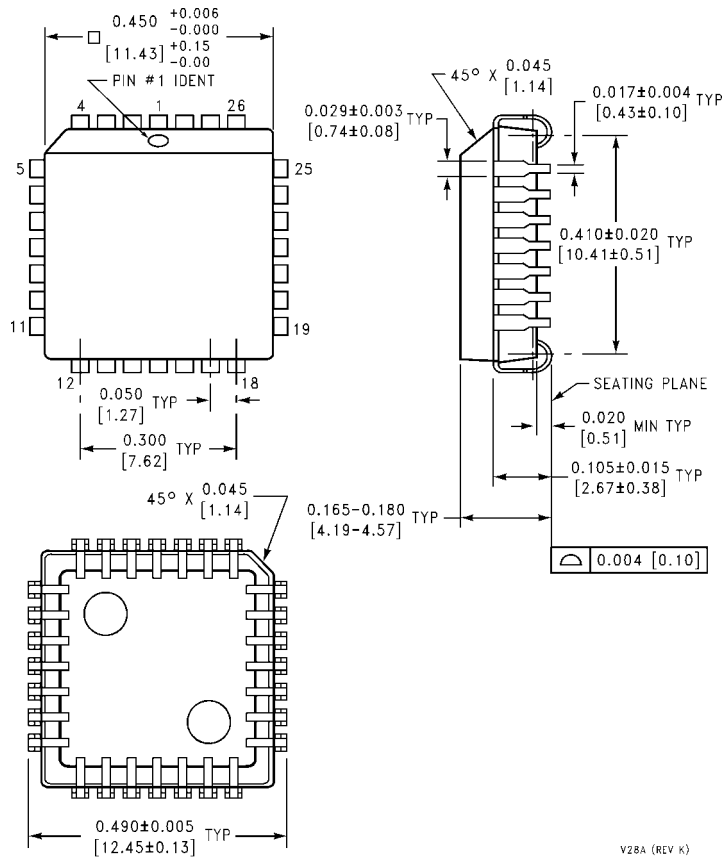

**28-Lead Plastic Lead Chip Carrier (PLCC), JEDEC MO-047, 0.450 Square Package Number V28A**

V28A (REV K)

Fairchild does not assume any responsibility for use of any circuitry described, no circuit patent licenses are implied and Fairchild reserves the right at any time without notice to change said circuitry and specifications.

**LIFE SUPPORT POLICY**

FAIRCHILD'S PRODUCTS ARE NOT AUTHORIZED FOR USE AS CRITICAL COMPONENTS IN LIFE SUPPORT DEVICES OR SYSTEMS WITHOUT THE EXPRESS WRITTEN APPROVAL OF THE PRESIDENT OF FAIRCHILD SEMICONDUCTOR CORPORATION. As used herein:

1. Life support devices or systems are devices or systems which, (a) are intended for surgical implant into the body, or (b) support or sustain life, and (c) whose failure to perform when properly used in accordance with instructions for use provided in the labeling, can be reasonably expected to result in a significant injury to the user.
2. A critical component in any component of a life support device or system whose failure to perform can be reasonably expected to cause the failure of the life support device or system, or to affect its safety or effectiveness.

[www.fairchildsemi.com](http://www.fairchildsemi.com)