

TRIPLE 2-CHANNEL ANALOG MULTIPLEXER/DEMULTIPLEXER

FEATURES

- Low "ON" resistance:  
80 Ω (typ.) at  $V_{CC} - V_{EE} = 4.5\text{ V}$   
70 Ω (typ.) at  $V_{CC} - V_{EE} = 6.0\text{ V}$   
60 Ω (typ.) at  $V_{CC} - V_{EE} = 9.0\text{ V}$
- Logic level translation:  
to enable 5 V logic to communicate  
with ± 5 V analog signals
- Typical "break before make" built in
- Output capability: non-standard
- I<sub>CC</sub> category: MSI

GENERAL DESCRIPTION

The 74HC/HCT4053 are high-speed Si-gate CMOS devices and are pin compatible with the "4053" of the "4000B" series. They are specified in compliance with JEDEC standard no. 7A.

The 74HC/HCT4053 are triple 2-channel analog multiplexers/demultiplexers with a common enable input (E̅). Each multiplexer/demultiplexer has two independent inputs/outputs (nY<sub>0</sub> and nY<sub>1</sub>), a common input/output (nZ) and three digital select inputs (S<sub>1</sub> to S<sub>3</sub>).

With E̅ LOW, one of the two switches is selected (low impedance ON-state) by S<sub>1</sub> to S<sub>3</sub>. With E̅ HIGH, all switches are in the high impedance OFF-state, independent of S<sub>1</sub> to S<sub>3</sub>.

V<sub>CC</sub> and GND are the supply voltage pins for the digital control inputs (S<sub>1</sub> to S<sub>3</sub>, and E̅). The V<sub>CC</sub> to GND ranges are 2.0 to 10.0 V for HC and 4.5 to 5.5 V for HCT. The analog inputs/outputs (nY<sub>0</sub> and nY<sub>1</sub>, and nZ) can swing between V<sub>CC</sub> as a positive limit and V<sub>EE</sub> as a negative limit. V<sub>CC</sub> - V<sub>EE</sub> may not exceed 10.0 V.

For operation as a digital multiplexer/demultiplexer, V<sub>EE</sub> is connected to GND (typically ground).

SYMBOL	PARAMETER	CONDITIONS	TYPICAL		UNIT
			HC	HCT	
t <sub>PZH</sub> / t <sub>PZL</sub>	turn "ON" time E̅ to V <sub>OS</sub> S <sub>n</sub> to V <sub>OS</sub>	C <sub>L</sub> = 15 pF R <sub>L</sub> = 1 kΩ V <sub>CC</sub> = 5 V	17	23	ns
			21	21	ns
t <sub>PHZ</sub> / t <sub>PLZ</sub>	turn "OFF" time E̅ to V <sub>OS</sub> S <sub>n</sub> to V <sub>OS</sub>		18	20	ns
			17	19	ns
C <sub>I</sub>	input capacitance		3.5	3.5	pF
C <sub>PD</sub>	power dissipation capacitance per switch		notes 1 and 2	36	36
C <sub>S</sub>	max. switch capacitance independent (Y) common (Z)	5	5	pF	
		8	8	pF	

V<sub>EE</sub> = GND = 0 V; T<sub>amb</sub> = 25 °C; t<sub>r</sub> = t<sub>f</sub> = 6 ns

Notes

1. C<sub>PD</sub> is used to determine the dynamic power dissipation (P<sub>D</sub> in μW):

$$P_D = C_{PD} \times V_{CC}^2 \times f_i + \sum \{ (C_L + C_S) \times V_{CC}^2 \times f_o \}$$

where:  
f<sub>i</sub> = input frequency in MHz  
f<sub>o</sub> = output frequency in MHz  
Σ{(C<sub>L</sub> + C<sub>S</sub>) × V<sub>CC</sub><sup>2</sup> × f<sub>o</sub>} = sum of outputs  
C<sub>L</sub> = output load capacitance in pF  
C<sub>S</sub> = max. switch capacitance in pF  
V<sub>CC</sub> = supply voltage in V

2. For HC the condition is V<sub>1</sub> = GND to V<sub>CC</sub>  
For HCT the condition is V<sub>1</sub> = GND to V<sub>CC</sub> - 1.5 V

PACKAGE OUTLINES

16-lead DIL; plastic (SOT38Z).  
16-lead mini-pack; plastic (SO16; SOT109A).

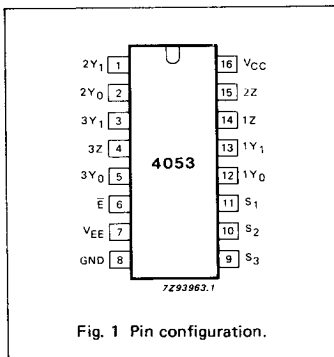

Fig. 1 Pin configuration.

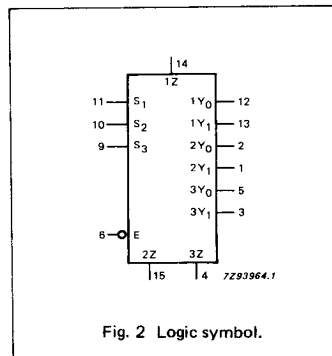

Fig. 2 Logic symbol.

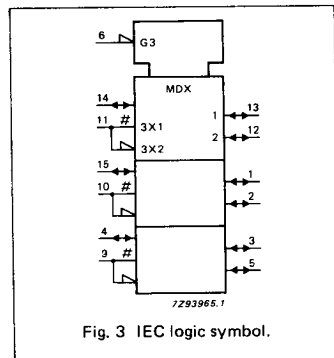

Fig. 3 IEC logic symbol.

**PIN DESCRIPTION**

PIN NO.	SYMBOL	NAME AND FUNCTION
2, 1	2Y <sub>0</sub> , 2Y <sub>1</sub>	independent inputs/outputs
5, 3	3Y <sub>0</sub> , 3Y <sub>1</sub>	independent inputs/outputs
6	E	enable input (active LOW)
7	V <sub>EE</sub>	negative supply voltage
8	GND	ground (0 V)
11, 10, 9	S <sub>1</sub> to S <sub>3</sub>	select inputs
12, 13	1Y <sub>0</sub> , 1Y <sub>1</sub>	independent inputs/outputs
14, 15, 4	1Z to 3Z	common inputs/outputs
16	V <sub>CC</sub>	positive supply voltage

**APPLICATIONS**

- Analog multiplexing and demultiplexing
- Digital multiplexing and demultiplexing
- Signal gating

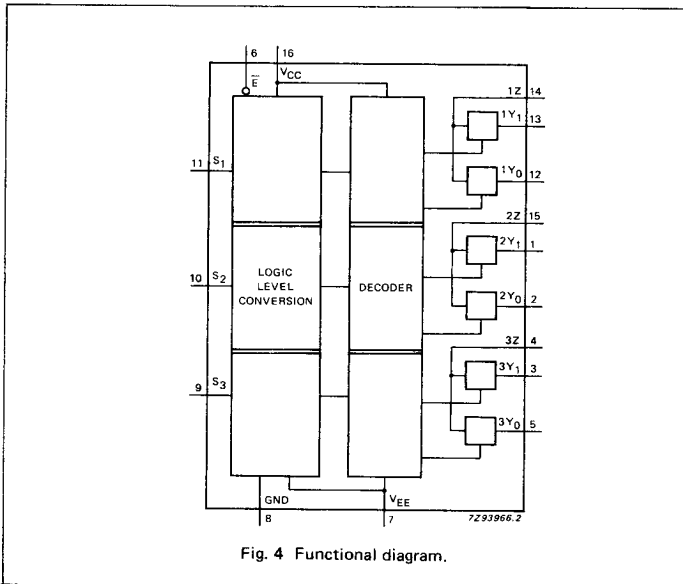

Fig. 4 Functional diagram.

**FUNCTION TABLE**

INPUTS		CHANNEL ON
E	S <sub>n</sub>	
L	L	nY <sub>0</sub> – nZ
L	H	nY <sub>1</sub> – nZ
H	X	none

H = HIGH voltage level  
L = LOW voltage level  
X = don't care

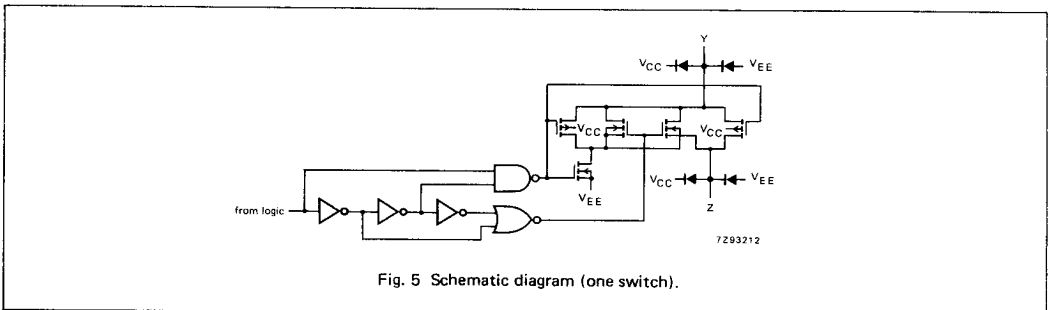

Fig. 5 Schematic diagram (one switch).

**RATINGS**

Limiting values in accordance with the Absolute Maximum System (IEC 134)

Voltages are referenced to  $V_{EE} = \text{GND}$  (ground = 0 V)

SYMBOL	PARAMETER	MIN.	MAX.	UNIT	CONDITIONS
$V_{CC}$	DC supply voltage	-0.5	+11.0	V	
$\pm I_{IK}$	DC digital input diode current		20	mA	for $V_I < -0.5 \text{ V}$ or $V_I > V_{CC} + 0.5 \text{ V}$
$\pm I_{SK}$	DC switch diode current		20	mA	for $V_S < -0.5 \text{ V}$ or $V_S > V_{CC} + 0.5 \text{ V}$
$\pm I_S$	DC switch current		25	mA	for $-0.5 \text{ V} < V_S < V_{CC} + 0.5 \text{ V}$
$\pm I_{EE}$	DC $V_{EE}$ current		20	mA	
$\pm I_{CC}$ ; $\pm I_{GND}$	DC $V_{CC}$ or GND current		50	mA	
$T_{stg}$	storage temperature range	-65	+150	$^{\circ}\text{C}$	
$P_{tot}$	power dissipation per package				for temperature range: $-40$ to $+125^{\circ}\text{C}$ 74HC/HCT
	plastic DIL		750	mW	above $+70^{\circ}\text{C}$ : derate linearly with 12 mW/K
	plastic mini-pack (SO)		500	mW	above $+70^{\circ}\text{C}$ : derate linearly with 8 mW/K
$P_S$	power dissipation per switch		100	mW	

**Note to ratings**

To avoid drawing  $V_{CC}$  current out of terminals nZ, when switch current flows in terminals  $nY_n$ , the voltage drop across the bidirectional switch must not exceed 0.4 V. If the switch current flows into terminals nZ, no  $V_{CC}$  current will flow out of terminals  $nY_n$ . In this case there is no limit for the voltage drop across the switch, but the voltages at  $nY_n$  and nZ may not exceed  $V_{CC}$  or  $V_{EE}$ .

**RECOMMENDED OPERATING CONDITIONS**

SYMBOL	PARAMETER	74HC			74HCT			UNIT	CONDITIONS
		min.	typ.	max.	min.	typ.	max.		
$V_{CC}$	DC supply voltage $V_{CC}-\text{GND}$	2.0	5.0	10.0	4.5	5.0	5.5	V	see Figs 6 and 7
$V_{CC}$	DC supply voltage $V_{CC}-V_{EE}$	2.0	5.0	10.0	2.0	5.0	10.0	V	see Figs 6 and 7
$V_I$	DC input voltage range	GND		$V_{CC}$	GND		$V_{CC}$	V	
$V_S$	DC switch voltage range	$V_{EE}$		$V_{CC}$	$V_{EE}$		$V_{CC}$	V	
$T_{amb}$	operating ambient temperature range	-40		+85	-40		+85	$^{\circ}\text{C}$	see DC and AC CHARACTERISTICS
$T_{amb}$	operating ambient temperature range	-40		+125	-40		+125	$^{\circ}\text{C}$	
$t_r, t_f$	input rise and fall times		6.0	1000 500 400 250		6.0	500	ns	$V_{CC} = 2.0 \text{ V}$ $V_{CC} = 4.5 \text{ V}$ $V_{CC} = 6.0 \text{ V}$ $V_{CC} = 10.0 \text{ V}$

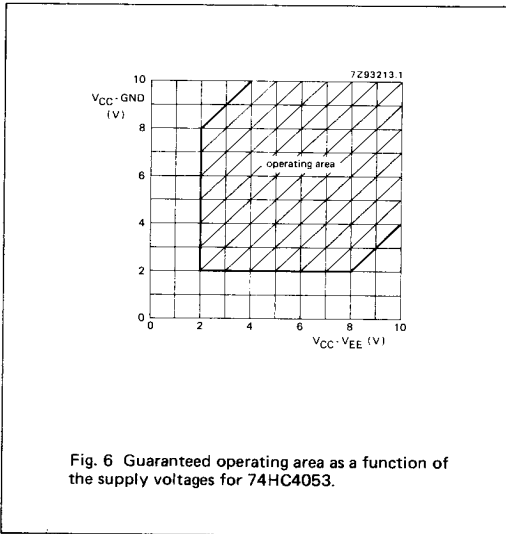

Fig. 6 Guaranteed operating area as a function of the supply voltages for 74HC4053.

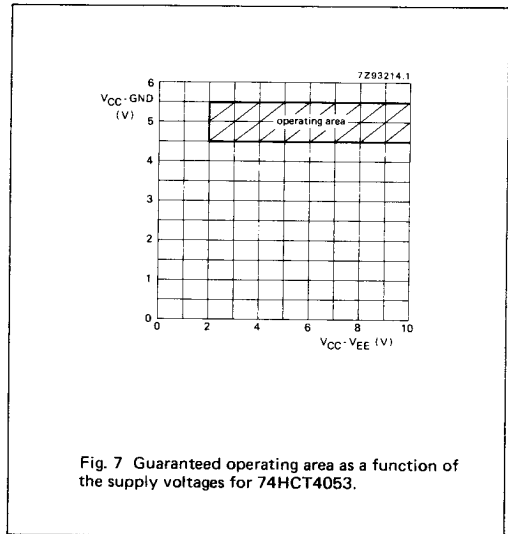

Fig. 7 Guaranteed operating area as a function of the supply voltages for 74HCT4053.

**DC CHARACTERISTICS FOR 74HC/HCT**

For 74HC:  $V_{CC} - GND$  or  $V_{CC} - V_{EE} = 2.0, 4.5, 6.0$  and  $9.0$  V

For 74HCT:  $V_{CC} - GND = 4.5$  and  $5.5$  V;  $V_{CC} - V_{EE} = 2.0, 4.5, 6.0$  and  $9.0$  V

SYMBOL	PARAMETER	$T_{amb}$ (°C)						UNIT	TEST CONDITIONS				
		74HC/HCT							$V_{CC}$ V	$V_{EE}$ V	$I_S$ $\mu A$	$V_{is}$	$V_i$
		+25		-40 to +85		-40 to +125							
		min.	typ.	max.	min.	max.	min.		max.				
$R_{ON}$	ON resistance (peak)	-	-	-	-	-	-	$\Omega$	2.0	0	100	$V_{CC}$ to $V_{EE}$	$V_{IH}$ or $V_{IL}$
		100	180	225	270	200	240	$\Omega$	4.5	0	1000		
		90	160	200	240	195	165	$\Omega$	6.0	0	1000		
$R_{ON}$	ON resistance (rail)	150	-	-	-	-	-	$\Omega$	2.0	0	100	$V_{EE}$	$V_{IH}$ or $V_{IL}$
		80	140	175	210	180	160	$\Omega$	4.5	0	1000		
		70	120	150	180	160	130	$\Omega$	6.0	0	1000		
$R_{ON}$	ON resistance (rail)	150	-	-	-	-	-	$\Omega$	2.0	0	100	$V_{CC}$	$V_{IH}$ or $V_{IL}$
		90	160	200	240	210	180	$\Omega$	4.5	0	1000		
		80	140	175	210	180	150	$\Omega$	6.0	0	1000		
$\Delta R_{ON}$	maximum $\Delta R_{ON}$ resistance between any two channels	-	-	-	-	-	-	$\Omega$	2.0	0	-	$V_{CC}$ to $V_{EE}$	$V_{IH}$ or $V_{IL}$
		9	-	-	-	-	-	$\Omega$	4.5	0	-		
		8	-	-	-	-	-	$\Omega$	6.0	0	-		
		6	-	-	-	-	-	$\Omega$	4.5	-4.5	-		

**Notes to DC characteristics**

- At supply voltages ( $V_{CC} - V_{EE}$ ) approaching 2.0 V the analog switch ON-resistance becomes extremely non-linear. Therefore it is recommended that these devices be used to transmit digital signals only, when using these supply voltages.
- For test circuit measuring  $R_{ON}$  see Fig. 8.

## DC CHARACTERISTICS FOR 74HC

Voltages are referenced to GND (ground = 0 V)

SYMBOL	PARAMETER	T <sub>amb</sub> (°C)						UNIT	TEST CONDITIONS				
		74HC							V <sub>CC</sub> V	V <sub>EE</sub> V	V <sub>I</sub>	OTHER	
		+25			-40 to +85		-40 to +125						
		min.	typ.	max.	min.	max.	min.		max.				
V <sub>IH</sub>	HIGH level input voltage	1.5 3.15 4.2 6.3	1.2 2.4 3.2 4.7		1.5 3.15 4.2 6.3		1.5 3.15 4.2 6.3	V	2.0 4.5 6.0 9.0				
V <sub>IL</sub>	LOW level input voltage		0.8 2.1 2.8 4.3	0.5 1.35 1.8 2.7		0.5 1.35 1.8 2.7		0.5 1.35 1.8 2.7	V	2.0 4.5 6.0 9.0			
±I <sub>I</sub>	input leakage current			0.1 0.2		1.0 2.0		1.0 2.0	μA	6.0 10.0	0 0	V <sub>CC</sub> or GND	
±I <sub>S</sub>	analog switch OFF-state current per channel			0.1		1.0		1.0	μA	10.0	0	V <sub>IH</sub> or V <sub>IL</sub>	V <sub>S</sub>   = V <sub>CC</sub> - V <sub>EE</sub> (see Fig. 10)
±I <sub>S</sub>	analog switch OFF-state current all channels			0.1		1.0		1.0	μA	10.0	0	V <sub>IH</sub> or V <sub>IL</sub>	V <sub>S</sub>   = V <sub>CC</sub> - V <sub>EE</sub> (see Fig. 10)
±I <sub>S</sub>	analog switch ON-state current			0.1		1.0		1.0	μA	10.0	0	V <sub>IH</sub> or V <sub>IL</sub>	V <sub>S</sub>   = V <sub>CC</sub> - V <sub>EE</sub> (see Fig. 11)
I <sub>CC</sub>	quiescent supply current			8.0 16.0		80.0 160.0		160.0 320.0	μA	6.0 10.0	0 0	V <sub>CC</sub> or GND	V <sub>is</sub> = V <sub>EE</sub> or V <sub>CC</sub> ; V <sub>os</sub> = V <sub>CC</sub> or V <sub>EE</sub>

AC CHARACTERISTICS FOR 74HC

GND = 0 V;  $t_r = t_f = 6$  ns;  $C_L = 50$  pF

SYMBOL	PARAMETER	T <sub>amb</sub> (°C)						UNIT	TEST CONDITIONS			
		74HC							V <sub>CC</sub> V	V <sub>EE</sub> V	OTHER	
		+25			-40 to +85		-40 to +125					
		min.	typ.	max.	min.	max.	min.		max.			
t <sub>PHL</sub> / t <sub>PLH</sub>	propagation delay V <sub>is</sub> to V <sub>os</sub>		15 5 4 4	60 12 10 8		75 15 13 10		90 18 15 12	ns	2.0 4.5 6.0 4.5	0 0 0 -4.5	R <sub>L</sub> = ∞; C <sub>L</sub> = 50 pF (see Fig. 18)
t <sub>PZH</sub> / t <sub>PZL</sub>	turn "ON" time E to V <sub>os</sub>		60 20 16 15	220 44 37 31		275 55 47 39		330 66 56 47	ns	2.0 4.5 6.0 4.5	0 0 0 -4.5	R <sub>L</sub> = 1 kΩ; C <sub>L</sub> = 50 pF (see Figs 19, 20 and 21)
t <sub>PZH</sub> / t <sub>PZL</sub>	turn "ON" time S <sub>N</sub> to V <sub>os</sub>		75 25 20 15	220 44 37 31		275 55 47 39		330 66 56 47	ns	2.0 4.5 6.0 4.5	0 0 0 -4.5	R <sub>L</sub> = 1 kΩ; C <sub>L</sub> = 50 pF (see Figs 19, 20 and 21)
t <sub>PHZ</sub> / t <sub>PLZ</sub>	turn "OFF" time E to V <sub>os</sub>		63 21 17 15	210 42 36 29		265 53 45 36		315 63 54 44	ns	2.0 4.5 6.0 4.5	0 0 0 -4.5	R <sub>L</sub> = 1 kΩ; C <sub>L</sub> = 50 pF (see Figs 19, 20 and 21)
t <sub>PHZ</sub> / t <sub>PLZ</sub>	turn "OFF" time S <sub>N</sub> to V <sub>os</sub>		60 20 16 15	210 42 36 29		265 53 45 36		315 63 54 44	ns	2.0 4.5 6.0 4.5	0 0 0 -4.5	R <sub>L</sub> = 1 kΩ; C <sub>L</sub> = 50 pF (see Figs 19, 20 and 21)

**DC CHARACTERISTICS FOR 74HCT**

Voltages are referenced to GND (ground = 0 V)

SYMBOL	PARAMETER	T <sub>amb</sub> (°C)						UNIT	TEST CONDITIONS				
		74HCT							V <sub>CC</sub> V	V <sub>EE</sub> V	V <sub>I</sub>	OTHER	
		+25			-40 to +85		-40 to +125						
		min.	typ.	max.	min.	max.	min.						max.
V <sub>IH</sub>	HIGH level input voltage	2.0	1.6		2.0		2.0		V	4.5 to 5.5			
V <sub>IL</sub>	LOW level input voltage		1.2	0.8		0.8		0.8	V	4.5 to 5.5			
±I <sub>I</sub>	input leakage current			0.1		1.0		1.0	μA	5.5	0	V <sub>CC</sub> or GND	
±I <sub>S</sub>	analog switch OFF-state current per channel			0.1		1.0		1.0	μA	10.0	0	V <sub>IH</sub> or V <sub>IL</sub>	V <sub>S</sub>   = V <sub>CC</sub> - V <sub>EE</sub> (see Fig. 10)
±I <sub>S</sub>	analog switch OFF-state current all channels			0.1		1.0		1.0	μA	10.0	0	V <sub>IH</sub> or V <sub>IL</sub>	V <sub>S</sub>   = V <sub>CC</sub> - V <sub>EE</sub> (see Fig. 10)
±I <sub>S</sub>	analog switch ON-state current			0.1		1.0		1.0	μA	10.0	0	V <sub>IH</sub> or V <sub>IL</sub>	V <sub>S</sub>   = V <sub>CC</sub> - V <sub>EE</sub> (see Fig. 11)
I <sub>CC</sub>	quiescent supply current			8.0 16.0		80.0 160.0		160.0 320.0	μA	5.5 5.0	0 -5.0	V <sub>CC</sub> or GND	V <sub>is</sub> = V <sub>EE</sub> or V <sub>CC</sub> ; V <sub>os</sub> = V <sub>CC</sub> or V <sub>EE</sub>
ΔI <sub>CC</sub>	additional quiescent supply current per input pin for unit load coefficient is 1 (note 1)		100	360		450		490	μA	4.5 to 5.5	0	V <sub>CC</sub> -2.1 V	other inputs at V <sub>CC</sub> or GND

**Note to HCT types**

- The value of additional quiescent supply current (ΔI<sub>CC</sub>) for a unit load of 1 is given here. To determine ΔI<sub>CC</sub> per input, multiply this value by the unit load coefficient shown in the table below.

INPUT	UNIT LOAD COEFFICIENT
S <sub>n</sub>	0.50
E	0.50

## AC CHARACTERISTICS FOR 74HCT

GND = 0 V;  $t_r = t_f = 6$  ns;  $C_L = 50$  pF

SYMBOL	PARAMETER	$T_{amb}$ (°C)						UNIT	TEST CONDITIONS			
		74HCT							$V_{CC}$ V	$V_{EE}$ V	OTHER	
		+25			-40 to +85		-40 to +125					
		min.	typ.	max.	min.	max.	min.		max.			
$t_{PHL}/$ $t_{PLH}$	propagation delay $V_{is}$ to $V_{os}$		5 4	12 8		15 10		18 12	ns	4.5 4.5	0 -4.5	$R_L = \infty$ ; $C_L = 50$ pF (see Fig. 18)
$t_{PZH}/$ $t_{PZL}$	turn "ON" time $\bar{E}$ to $V_{os}$		27 16	48 34		60 43		72 51	ns	4.5 4.5	0 -4.5	$R_L = 1$ k $\Omega$ ; $C_L = 50$ pF (see Figs 19, 20 and 21)
$t_{PZH}/$ $t_{PZL}$	turn "ON" time $S_n$ to $V_{os}$		25 16	48 34		60 43		72 51	ns	4.5 4.5	0 -4.5	$R_L = 1$ k $\Omega$ ; $C_L = 50$ pF (see Figs 19, 20 and 21)
$t_{PHZ}/$ $t_{PLZ}$	turn "OFF" time $\bar{E}$ to $V_{os}$		24 15	44 31		55 39		66 47	ns	4.5 4.5	0 -4.5	$R_L = 1$ k $\Omega$ ; $C_L = 50$ pF (see Figs 19, 20 and 21)
$t_{PHZ}/$ $t_{PLZ}$	turn "OFF" time $S_n$ to $V_{os}$		22 15	44 31		55 39		66 47	ns	4.5 4.5	0 -4.5	$R_L = 1$ k $\Omega$ ; $C_L = 50$ pF (see Figs 19, 20 and 21)

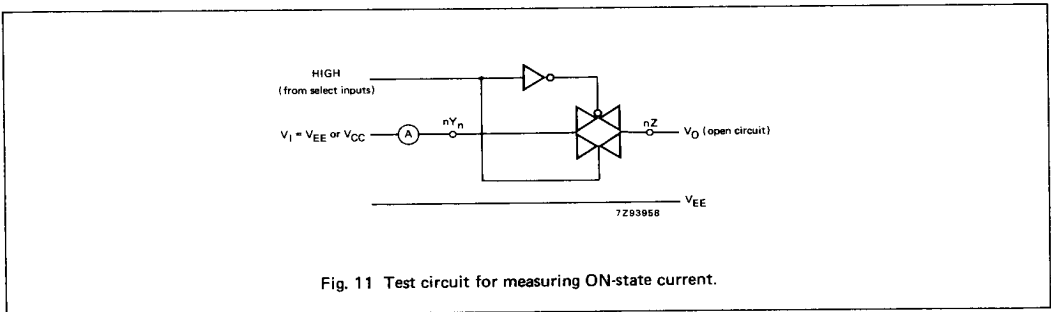
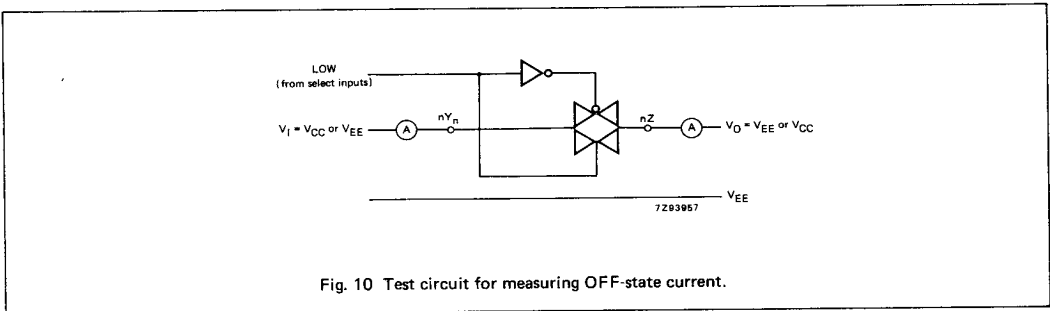
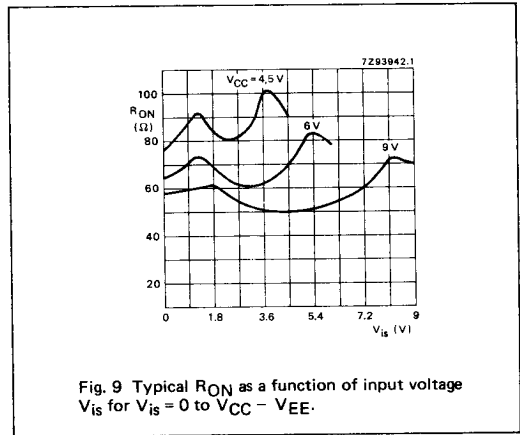
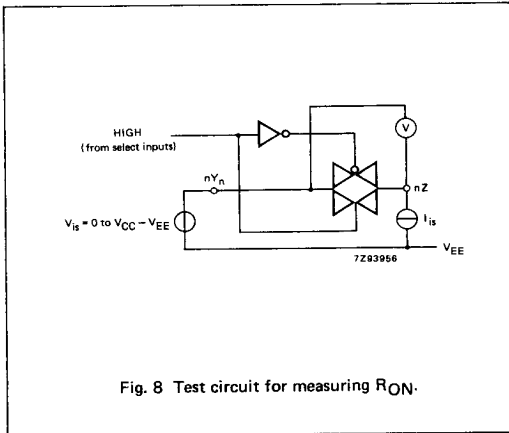

## ADDITIONAL AC CHARACTERISTICS FOR 74HC/HCT

Recommended conditions and typical values

GND = 0 V;  $T_{amb} = 25^\circ\text{C}$ 

SYMBOL	PARAMETER	typ.	UNIT	V <sub>CC</sub> V	V <sub>EE</sub> V	V <sub>is(p-p)</sub> V	CONDITIONS
	sine-wave distortion f = 1 kHz	0.04 0.02	% %	2.25 4.5	-2.25 -4.5	4.0 8.0	R <sub>L</sub> = 10 k $\Omega$ ; C <sub>L</sub> = 50 pF (see Fig. 14)
	sine-wave distortion f = 10 kHz	0.12 0.06	% %	2.25 4.5	-2.25 -4.5	4.0 8.0	R <sub>L</sub> = 10 k $\Omega$ ; C <sub>L</sub> = 50 pF (see Fig. 14)
	switch "OFF" signal feed-through	-50 -50	dB dB	2.25 4.5	-2.25 -4.5	note 1	R <sub>L</sub> = 600 $\Omega$ ; C <sub>L</sub> = 50 pF f = 1 MHz (see Figs 12 and 15)
	crosstalk between any two switches/ multiplexers	-60 -60	dB dB	2.25 4.5	-2.25 -4.5	note 1	R <sub>L</sub> = 600 $\Omega$ ; C <sub>L</sub> = 50 pF; f = 1 MHz (see Fig. 16)
V <sub>(p-p)</sub>	crosstalk voltage between control and any switch (peak-to-peak value)	110 220	mV mV	4.5 4.5	0 -4.5		R <sub>L</sub> = 600 $\Omega$ ; C <sub>L</sub> = 50 pF; f = 1 MHz ( $\bar{E}$ or S <sub>n</sub> , square-wave between V <sub>CC</sub> and GND, t <sub>r</sub> = t <sub>f</sub> = 6 ns) (see Fig. 17)
f <sub>max</sub>	minimum frequency response (-3dB)	160 170	MHz MHz	2.25 4.5	-2.25 -4.5	note 2	R <sub>L</sub> = 50 $\Omega$ ; C <sub>L</sub> = 10 pF (see Figs 13 and 14)
C <sub>S</sub>	maximum switch capacitance independent (Y) common (Z)	5 8	pF pF				

## Notes to AC characteristics

## General note

V<sub>is</sub> is the input voltage at an nY<sub>n</sub> or nZ terminal, whichever is assigned as an input.V<sub>os</sub> is the output voltage at an nY<sub>n</sub> or nZ terminal, whichever is assigned as an output.

## Notes

1. Adjust input voltage V<sub>is</sub> to 0 dBm level (0 dBm = 1 mW into 600  $\Omega$ ).
2. Adjust input voltage V<sub>is</sub> to 0 dBm level at V<sub>os</sub> for 1 MHz (0 dBm = 1 mW into 50  $\Omega$ ).

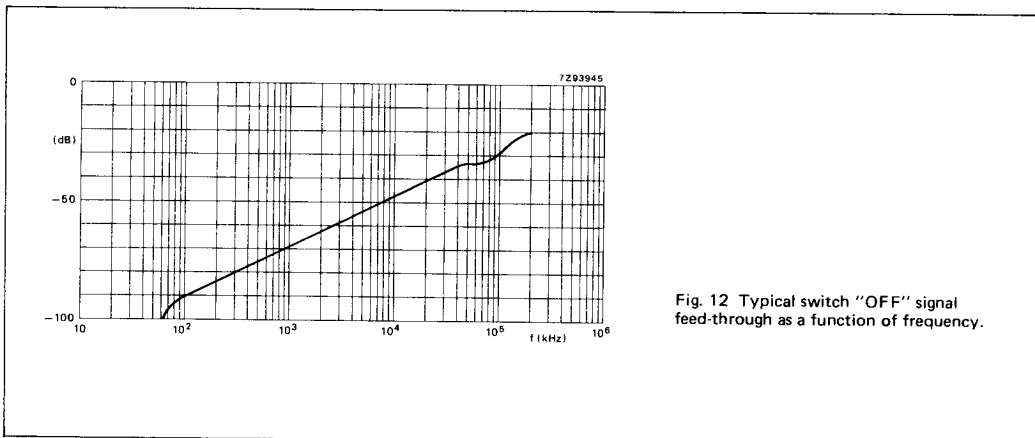
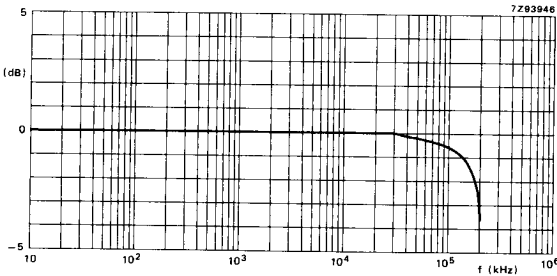

Fig. 12 Typical switch "OFF" signal feed-through as a function of frequency.



Note to Figs 12 and 13

Test conditions:  
 $V_{CC} = 4.5\text{ V}$ ;  $GND = 0\text{ V}$ ;  $V_{EE} = -4.5\text{ V}$ ;  
 $R_L = 50\ \Omega$ ;  $R_{source} = 1\text{ k}\Omega$ .

Fig. 13 Typical frequency response.

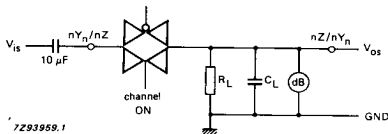

Fig. 14 Test circuit for measuring sine-wave distortion and minimum frequency response.

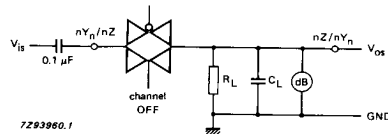

Fig. 15 Test circuit for measuring switch "OFF" signal feed-through.

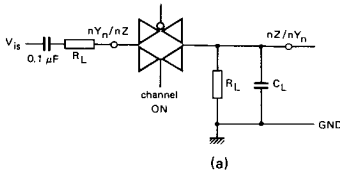

Fig. 16 Test circuits for measuring crosstalk between any two switches/multiplexers.  
 (a) channel ON condition; (b) channel OFF condition.

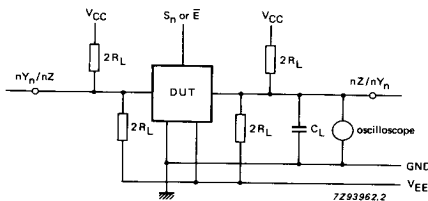
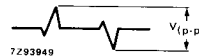

Fig. 17 Test circuit for measuring crosstalk between control and any switch.

Note to Fig. 17

The crosstalk is defined as follows  
 (oscilloscope output):



AC WAVEFORMS

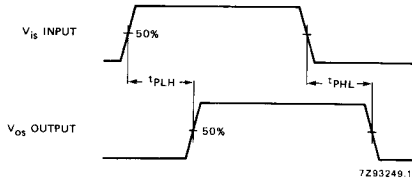

Fig. 18 Waveforms showing the input ( $V_{1S}$ ) to output ( $V_{O5}$ ) propagation delays.

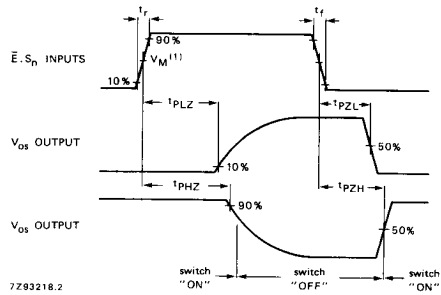

Fig. 19 Waveforms showing the turn-ON and turn-OFF times.

**Note to Fig. 19**

- (1) HC :  $V_M = 50\%$ ;  $V_I = \text{GND to } V_{CC}$ .
- HCT:  $V_M = 1.3 \text{ V}$ ;  $V_I = \text{GND to } 3 \text{ V}$ .

TEST CIRCUIT AND WAVEFORMS

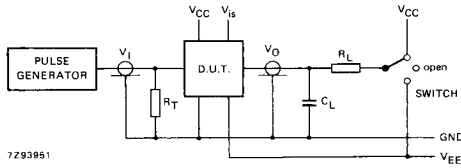

Fig. 20 Test circuit for measuring AC performance.

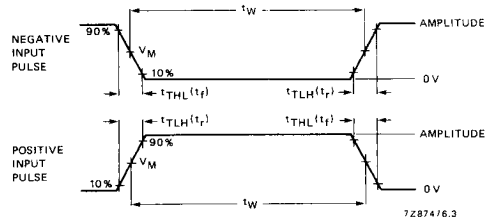

Fig. 21 Input pulse definitions.

Conditions

TEST	SWITCH	V <sub>is</sub>
t <sub>pZH</sub>	V <sub>EE</sub>	V <sub>CC</sub>
t <sub>pZL</sub>	V <sub>CC</sub>	V <sub>EE</sub>
t <sub>pHZ</sub>	V <sub>EE</sub>	V <sub>CC</sub>
t <sub>pLZ</sub>	V <sub>CC</sub>	V <sub>EE</sub>
others	open	pulse

FAMILY	AMPLITUDE	V <sub>M</sub>	t <sub>r</sub> ; t <sub>f</sub>	
			f <sub>max</sub> : PULSE WIDTH	OTHER
74HC	V <sub>CC</sub>	50%	< 2 ns	6 ns
74HCT	3.0 V	1.3 V	< 2 ns	6 ns

Definitions for Figs 20 and 21:

- C<sub>L</sub> = load capacitance including jig and probe capacitance (see AC CHARACTERISTICS for values).
- R<sub>T</sub> = termination resistance should be equal to the output impedance Z<sub>O</sub> of the pulse generator.
- t<sub>r</sub> = t<sub>f</sub> = 6 ns; when measuring f<sub>max</sub>, there is no constraint on t<sub>r</sub>, t<sub>f</sub> with 50% duty factor.