

74LVTH16952

Low Voltage 16-Bit Registered Transceiver with 3-STATE Outputs

General Description

The LVTH16952 is a 16-bit registered transceiver. Two 8-bit back to back registers store data flowing in both directions between two bidirectional buses. Separate clock, clock enable, and output enable signals are provided for each register.

The LVTH16952 data inputs include bushold, eliminating the need for external pull-up resistors to hold unused inputs.

The registered transceiver is designed for low-voltage (3.3V) V_{CC} applications, but with the capability to provide a TTL interface to a 5V environment.

The LVTH16952 is fabricated with an advanced BiCMOS technology to achieve high speed operation similar to 5V ABT while maintaining low power dissipation.

Features

- Input and output interface capability to systems at 5V V_{CC}
- Bushold data inputs eliminate the need for external pull-up resistors to hold unused inputs
- Live insertion/extraction permitted
- Power Up/Down high impedance provides glitch-free bus loading
- Outputs source/sink -32 mA/+64 mA
- Functionally compatible with the 74 series 16952
- Latch-up performance exceeds 500 mA

Ordering Code:

Order Number	Package Number	Package Description
74LVTH16952MEA	MS56A	56-Lead Shrink Small Outline Package (SSOP), JEDEC MO-118, 0.300 Wide
74LVTH16952MTD	MTD56	56-Lead Thin Shrink Small Outline Package (TSSOP), JEDEC MO-153, 6.1mm Wide

Devices also available in Tape and Reel. Specify by appending the suffix letter "X" to the ordering code.

74LVTH16952 Low Voltage 16-Bit Registered Transceiver with 3-STATE Outputs

Connection Diagram

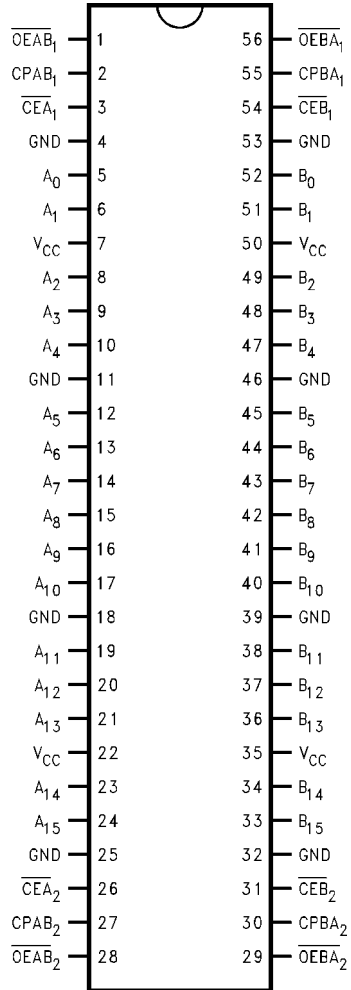

Pin Descriptions

Pin Names	Description
A ₀ -A ₁₆	Data Register A Inputs B-Register 3-STATE Outputs
B ₀ -B ₁₆	Data Register B Inputs A-Register 3-STATE Outputs
CPAB _n , CPBA _n	Clock Pulse Inputs
CEA _n , CEB _n	Clock Enable
OEAB _n , OEBA _n	Output Enable Inputs

Truth Table(Note 1)

Inputs				Internal Register Value	Output B _n
A _n	CPAB _n	CEA _n	OEAB _n		
X	X	H	L	NC	B ₀
X	X	H	H	NC	Z
L	↗	L	L	L	L
L	↗	L	H	L	Z
H	↗	L	L	H	H
H	↗	H	H	H	Z
X	L	X	L	NC	B ₀
X	H	X	L	NC	B ₀
X	L	X	H	NC	Z
X	H	X	H	NC	Z

H = HIGH Voltage Level
 L = LOW Voltage Level
 X = Immaterial
 Z = Output High Impedance
 ↗ = LOW-to-HIGH Transition.
 NC = No Change (state established by last valid CP)
 B₀ = State established by last valid CP

Note 1: A to B data flow shown; B to A flow control is the same, but used OEBA_n, CPBA_n and CEB_n.

Logic Diagram

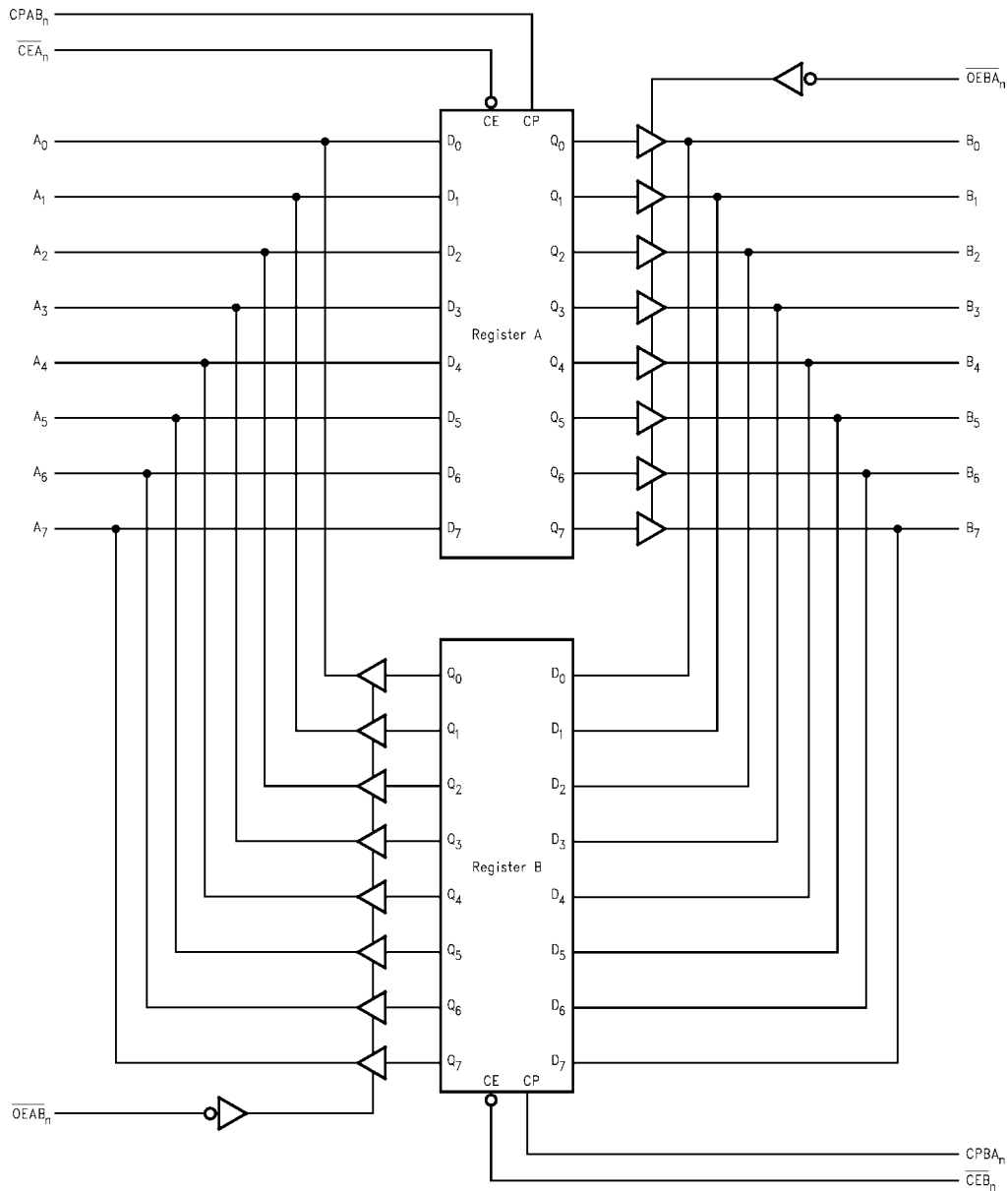

Note: _n for either byte 1 or byte 2.

Please note that these diagrams are provided only for the understanding of logic operations and should not be used to estimate propagation delays.

Absolute Maximum Ratings ^(Note 2)				
Symbol	Parameter	Value	Conditions	Units
V _{CC}	Supply Voltage	-0.5 to +4.6		V
V _I	DC Input Voltage	-0.5 to +7.0		V
V _O	DC Output Voltage	-0.5 to +7.0	Output in 3-STATE	V
		-0.5 to +7.0	Output in HIGH or LOW State (Note 3)	V
I _{IK}	DC Input Diode Current	-50	V _I < GND	mA
I _{OK}	DC Output Diode Current	-50	V _O < GND	mA
I _O	DC Output Current	64	V _O > V _{CC} Output at HIGH State	mA
		128	V _O > V _{CC} Output at LOW State	
I _{CC}	DC Supply Current per Supply Pin	±64		mA
I _{GND}	DC Ground Current per Ground Pin	±128		mA
T _{STG}	Storage Temperature	-65 to +150		°C

Recommended Operating Conditions				
Symbol	Parameter	Min	Max	Units
V _{CC}	Supply Voltage	2.7	3.6	V
V _I	Input Voltage	0	5.5	V
I _{OH}	HIGH-Level Output Current		-32	mA
I _{OL}	LOW-Level Output Current		64	
T _A	Free-Air Operating Temperature	-40	+85	°C
Δt/ΔV	Input Edge Rate, V _{IN} = 0.8V–2.0V, V _{CC} = 3.0V	0	10	ns/V

Note 2: Absolute Maximum continuous ratings are those values beyond which damage to the device may occur. Exposure to these conditions or conditions beyond those indicated may adversely affect device reliability. Functional operation under absolute maximum rated conditions is not implied.

Note 3: I_O Absolute Maximum Rating must be observed.

DC Electrical Characteristics							
Symbol	Parameter	V _{CC} (V)	T _A = -40°C to +85°C		Units	Conditions	
			Min	Max			
V _{IK}	Input Clamp Diode Voltage	2.7		-1.2	V	I _I = -18 mA	
V _{IH}	Input HIGH Voltage	2.7-3.6	2.0		V	V _O ≤ 0.1V or V _O ≥ V _{CC} - 0.1V	
V _{IL}	Input LOW Voltage	2.7-3.6		0.8			
V _{OH}	Output HIGH Voltage	2.7-3.6	V _{CC} - 0.2		V	I _{OH} = -100 μA	
		2.7	2.4		V	I _{OH} = -8 mA	
		3.0	2.0		V	I _{OH} = -32 mA	
V _{OL}	Output LOW Voltage	2.7		0.2	V	I _{OL} = 100 μA	
		2.7		0.5	V	I _{OL} = 24 mA	
		3.0		0.4	V	I _{OL} = 16 mA	
		3.0		0.5	V	I _{OL} = 32 mA	
		3.0		0.55	V	I _{OL} = 64 mA	
I _{I(HOLD)}	Bushold Input Minimum Drive	3.0	75		μA	V _I = 0.8V	
			-75		μA	V _I = 2.0V	
I _{I(OD)}	Bushold Input Over-Drive Current to Change State	3.0	500		μA	(Note 4)	
			-500		μA	(Note 5)	
I _I	Input Current	3.6		10	μA	V _I = 5.5V	
			Control Pins	3.6	±1	μA	V _I = 0V or V _{CC}
			Data Pins	3.6	-5	μA	V _I = 0V
					1	μA	V _I = V _{CC}
I _{OFF}	Power Off Leakage Current	0		±100	μA	0V ≤ V _I or V _O ≤ 5.5V	
I _{PU/PD}	Power Up/Down 3-STATE Output Current	0-1.5V		±100	μA	V _O = 0.5V to 3.0V V _I = GND or V _{CC}	
I _{OZL}	3-STATE Output Leakage Current	3.6		-5	μA	V _O = 0.0V	
I _{OZH}	3-STATE Output Leakage Current	3.6		5	μA	V _O = 3.6V	
I _{OZH+}	3-STATE Output Leakage Current	3.6		10	μA	V _{CC} < V _O ≤ 5.5V	
I _{CCH}	Power Supply Current	3.6		0.19	mA	Outputs High	
I _{CCL}	Power Supply Current	3.6		5	mA	Outputs Low	
I _{CCZ}	Power Supply Current	3.6		0.19	mA	Outputs Disabled	
I _{CCZ+}	Power Supply Current	3.6		0.19	mA	V _{CC} ≤ V _O ≤ 5.5V, Outputs Disabled	
ΔI _{CC}	Increase in Power Supply Current (Note 6)	3.6		0.2	mA	One Input at V _{CC} - 0.6V Other Inputs at V _{CC} or GND	
<p>Note 4: An external driver must source at least the specified current to switch from LOW-to-HIGH.</p> <p>Note 5: An external driver must sink at least the specified current to switch from HIGH-to-LOW.</p> <p>Note 6: This is the increase in supply current for each input that is at the specified voltage level rather than V_{CC} or GND.</p>							
Dynamic Switching Characteristics (Note 7)							
Symbol	Parameter	V _{CC} (V)	T _A = 25°C			Units	Conditions C _L = 50 pF, R _L = 500Ω
			Min	Typ	Max		
V _{OLP}	Quiet Output Maximum Dynamic V _{OL}	3.3		0.8		V	(Note 8)
V _{OLV}	Quiet Output Minimum Dynamic V _{OL}	3.3		-0.8		V	(Note 8)
<p>Note 7: Characterized in SSOP package. Guaranteed parameter, but not tested.</p> <p>Note 8: Max number of outputs defined as (n). n-1 data inputs are driven 0V to 3V. Output under test held LOW.</p>							

AC Electrical Characteristics

Symbol	Parameter	$T_A = -40^\circ\text{C to } +85^\circ\text{C}$ $C_L = 50\text{ pF}, R_L = 500\Omega$				Units
		$V_{CC} = 3.3 \pm 0.3\text{V}$		$V_{CC} = 2.7\text{V}$		
		Min	Max	Min	Max	
f_{MAX}		150		150		MHz
t_{PLH}	Propagation Delay	1.3	4.0	1.3	4.4	ns
t_{PHL}	CPBA or CPAB to A or B	1.3	4.2	1.3	4.4	
t_{PZH}	Output Enable Time	1.0	4.0	1.0	4.9	ns
t_{PZL}	\overline{OE} to A or B	1.0	4.4	1.0	5.2	
t_{PHZ}	Output Disable Time	2.1	5.7	2.1	6.2	ns
t_{PLZ}	\overline{OE} to A or B	2.1	5.1	2.1	5.3	
t_W	Pulse Width, CPAB or CPBA High or Low	3.3		3.3		ns
t_S	Setup Time	A or B before CPAB or CPBA	1.7		2.5	ns
		\overline{CEA} or \overline{CEB} before CPAB or CPBA	2.0		2.8	
t_H	Hold Time	A or B after CPAB or CPBA	0.8		0.0	ns
		\overline{CEA} or \overline{CEB} after CPAB or CPBA	0.4		0.0	
t_{OSLH}	Output to Output Skew (Note 9)		1.0		1.0	ns
t_{OSHL}			1.0		1.0	

Note 9: Skew is defined as the absolute value of the difference between the actual propagation delay for any two separate outputs of the same device. The specification applies to any outputs switching in the same direction, either HIGH-to-LOW (t_{OSHL}) or LOW-to-HIGH (t_{OSLH}).

Capacitance (Note 10)

Symbol	Parameter	Conditions	Typical	Units
C_{IN}	Input Capacitance	$V_{CC} = \text{OPEN}, V_I = 0\text{V or } V_{CC}$	4	pF
C_{IO}	Input/Output Capacitance	$V_{CC} = 3.0\text{V}, V_O = 0\text{V or } V_{CC}$	8	pF

Note 10: Capacitance is measured at frequency $f = 1\text{ MHz}$, per MIL-STD-883, Method 3012.

Physical Dimensions inches (millimeters) unless otherwise noted

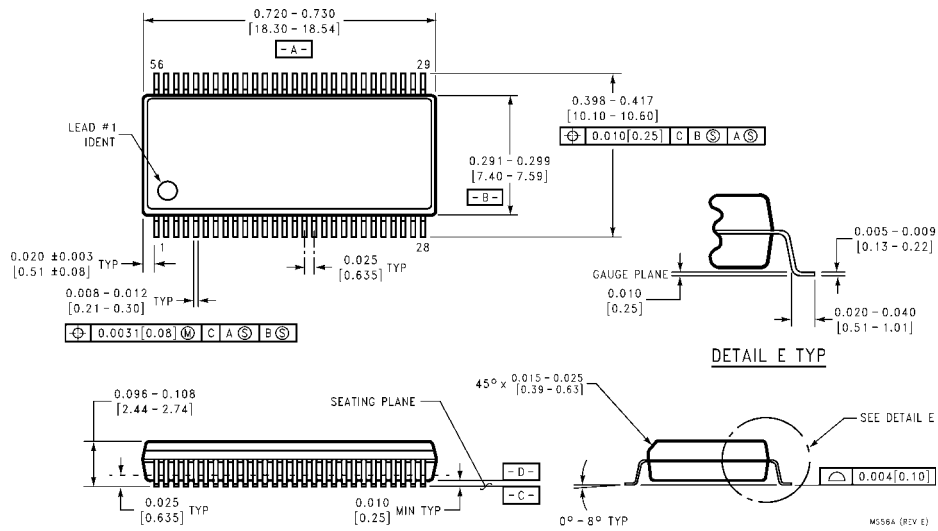

**56-Lead Shrink Small Outline Package (SSOP), JEDEC MO-118, 0.300 Wide
Package Number MS56A**

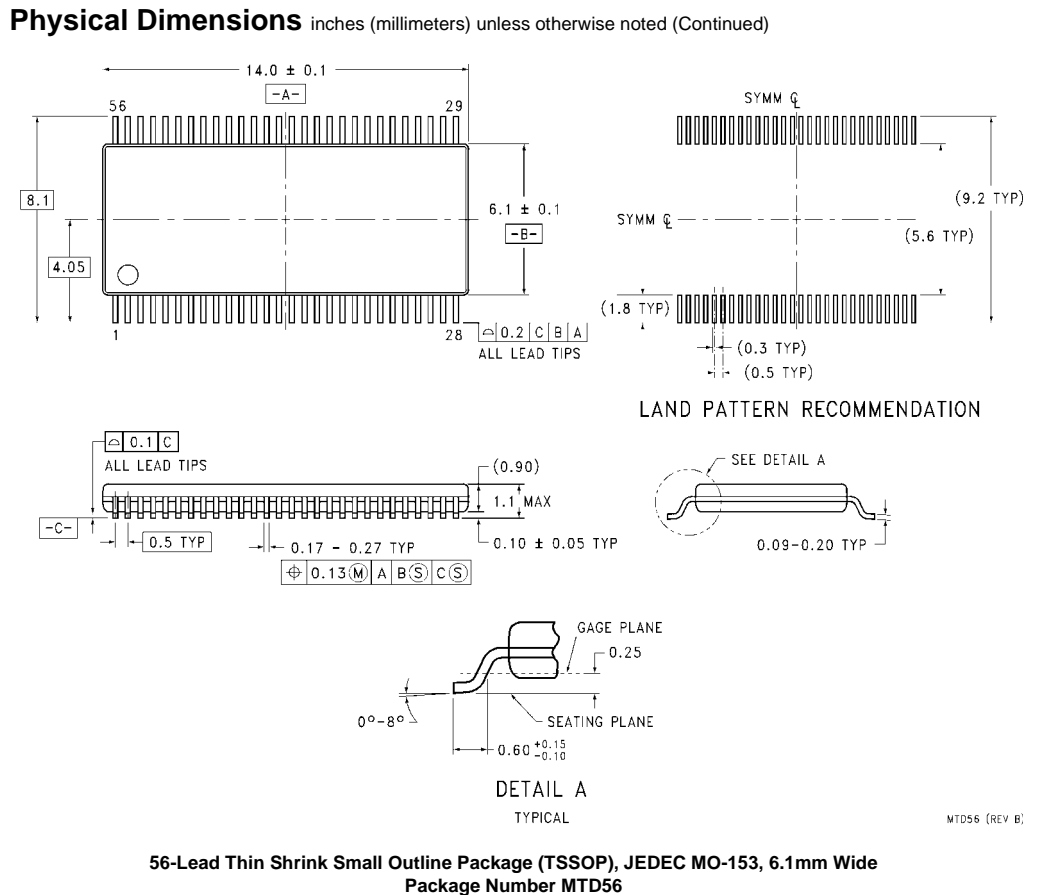

Fairchild does not assume any responsibility for use of any circuitry described, no circuit patent licenses are implied and Fairchild reserves the right at any time without notice to change said circuitry and specifications.

LIFE SUPPORT POLICY

FAIRCHILD'S PRODUCTS ARE NOT AUTHORIZED FOR USE AS CRITICAL COMPONENTS IN LIFE SUPPORT DEVICES OR SYSTEMS WITHOUT THE EXPRESS WRITTEN APPROVAL OF THE PRESIDENT OF FAIRCHILD SEMICONDUCTOR CORPORATION. As used herein:

1. Life support devices or systems are devices or systems which, (a) are intended for surgical implant into the body, or (b) support or sustain life, and (c) whose failure to perform when properly used in accordance with instructions for use provided in the labeling, can be reasonably expected to result in a significant injury to the user.
2. A critical component in any component of a life support device or system whose failure to perform can be reasonably expected to cause the failure of the life support device or system, or to affect its safety or effectiveness.

www.fairchildsemi.com