

74LVX174

Low Voltage Hex D-Type Flip-Flop with Master Reset

General Description

The LVX174 is a high-speed hex D flip-flop. The device is used primarily as a 6-bit edge-triggered storage register. The information on the D inputs is transferred to storage during the LOW-to-HIGH clock transition. The device has a Master Reset to simultaneously clear all flip-flops.

Features

- Input voltage level translation from 5V to 3V
- Ideal for low power/low noise 3.3V applications
- Guaranteed simultaneous switching noise level and dynamic threshold performance

Ordering Code:

| Order Number | Package Number | Package Description |
|--------------|----------------|--|
| 74LVX174M | M16A | 16-Lead Small Outline Integrated Circuit (SOIC), JEDEC MS-012, 0.150" Narrow |
| 74LVX174SJ | M16D | 16-Lead Small Outline Package (SOP), EIAJ TYPE II, 5.3mm Wide |
| 74LVX174MTC | MTC16 | 16-Lead Thin Shrink Small Outline Package (TSSOP), JEDEC MO-153, 4.4mm Wide |

Devices also available in Tape and Reel. Specify by appending the suffix letter "X" to the ordering code.

Logic Symbols

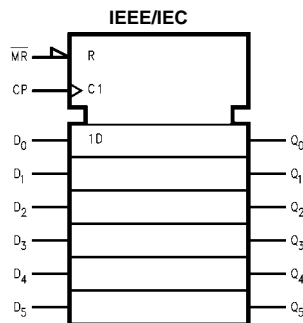
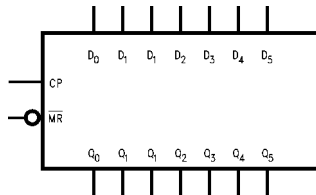

Connection Diagram

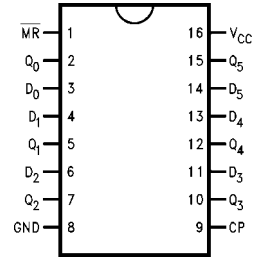

Pin Descriptions

| Pin Names | Description |
|--------------------------------|--------------------|
| D ₀ -D ₅ | Data Inputs |
| CP | Clock Pulse Input |
| $\overline{\text{MR}}$ | Master Reset Input |
| Q ₀ -Q ₅ | Outputs |

74LVX174 Low Voltage Hex D-Type Flip-Flop with Master Reset

Truth Table

| Operating Mode | Inputs | | | Outputs |
|----------------|-----------------|----|-------|---------|
| | \overline{MR} | CP | D_n | Q_n |
| Reset (Clear) | L | X | X | L |
| Load '1' | H | ↗ | H | H |
| Load '0' | H | ↗ | L | L |

H = HIGH Voltage Level
 L = LOW Voltage Level
 X = Immaterial
 ↗ = LOW-to-HIGH Transition

Logic Diagram

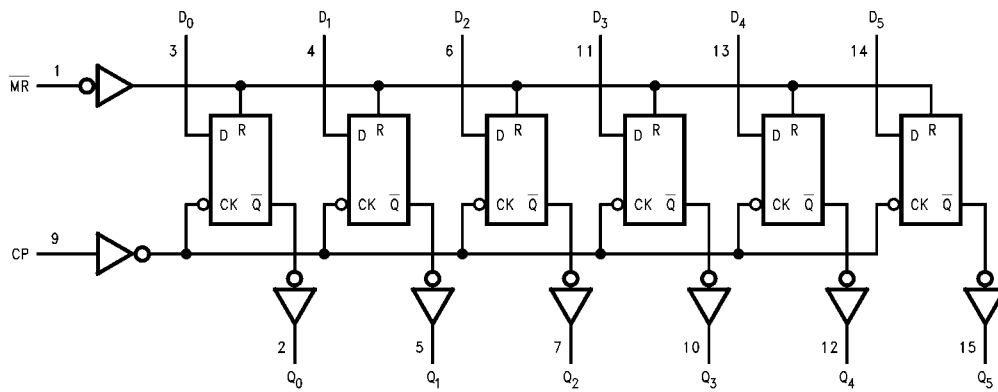

Absolute Maximum Ratings (Note 1)

| | |
|--------------------------------------|--------------------------|
| Supply Voltage (V_{CC}) | -0.5V to +7.0V |
| DC Input Diode Current (I_{IK}) | |
| $V_I = -0.5V$ | -20 mA |
| DC Input Voltage (V_I) | -0.5V to 7V |
| DC Output Diode Current (I_{OK}) | |
| $V_O = -0.5V$ | -20 mA |
| $V_O = V_{CC} + 0.5V$ | +20 mA |
| DC Output Voltage (V_O) | -0.5V to $V_{CC} + 0.5V$ |
| DC Output Source | |
| or Sink Current (I_O) | ± 25 mA |
| DC V_{CC} or Ground Current | |
| (I_{CC} or I_{GND}) | ± 50 mA |
| Storage Temperature (T_{STG}) | -65°C to +150°C |
| Power Dissipation (P_D) | 180 mW |

Recommended Operating Conditions (Note 2)

| | |
|--|--------------------|
| Supply Voltage (V_{CC}) | 2.0V to 3.6V |
| Input Voltage (V_I) | 0V to 5.5V |
| Output Voltage (V_O) | 0V to V_{CC} |
| Operating Temperature (T_A) | -40°C to +85°C |
| Input Rise and Fall Time ($\Delta t/\Delta V$) | 0 ns/V to 100 ns/V |

Note 1: The "Absolute Maximum Ratings" are those values beyond which the safety of the device cannot be guaranteed. The device should not be operated at these limits. The parametric values defined in the Electrical Characteristics tables are not guaranteed at the absolute maximum ratings. The "Recommended Operating Conditions" table will define the conditions for actual device operation.

Note 2: Unused inputs must be held HIGH or LOW. They may not float.

DC Electrical Characteristics

| Symbol | Parameter | V_{CC} | $T_A = +25^\circ\text{C}$ | | | $T_A = -40^\circ\text{C to } +85^\circ\text{C}$ | | Units | Conditions | |
|----------|------------------------------|----------|---------------------------|-----|-----------|---|-----------|---------------|-------------------------------|----------------------------|
| | | | Min | Typ | Max | Min | Max | | | |
| V_{IH} | HIGH Level Input Voltage | 2.0 | 1.5 | | | 1.5 | | V | | |
| | | 3.0 | 2.0 | | | 2.0 | | | | |
| | | 3.6 | 2.4 | | | 2.4 | | | | |
| V_{IL} | LOW Level Input Voltage | 2.0 | | | 0.5 | | 0.5 | V | | |
| | | 3.0 | | | 0.8 | | 0.8 | | | |
| | | 3.6 | | | 0.8 | | 0.8 | | | |
| V_{OH} | HIGH Level Output Voltage | 2.0 | 1.9 | 2.0 | | 1.9 | | V | $V_{IN} = V_{IL}$ or V_{IH} | $I_{OH} = -50 \mu\text{A}$ |
| | | 3.0 | 2.9 | 3.0 | | 2.9 | | | | $I_{OH} = -50 \mu\text{A}$ |
| | | 3.0 | 2.58 | | | 2.48 | | | | $I_{OH} = -4 \text{ mA}$ |
| V_{OL} | LOW Level Output Voltage | 2.0 | | 0.0 | 0.1 | | 0.1 | V | $V_{IN} = V_{IL}$ or V_{IH} | $I_{OL} = 50 \mu\text{A}$ |
| | | 3.0 | | 0.0 | 0.1 | | 0.1 | | | $I_{OL} = 50 \mu\text{A}$ |
| | | 3.0 | | | 0.36 | | 0.44 | | | $I_{OL} = 4 \text{ mA}$ |
| I_{IN} | Input Leakage Current | 3.6 | | | ± 0.1 | | ± 1.0 | μA | $V_{IN} = 5.5V$ or GND | |
| I_{CC} | Quiescent Supply Current | 3.6 | | | 4.0 | | 40.0 | μA | $V_{IN} = V_{CC}$ or GND | |

Noise Characteristics (Note 3)

| Symbol | Parameter | V_{CC} (V) | $T_A = 25^\circ\text{C}$ | | Units | C_L (pF) |
|-----------|--|-----------------|--------------------------|-------|-------|------------|
| | | | Typ | Limit | | |
| V_{OLP} | Quiet Output Maximum Dynamic V_{OL} | 3.3 | 0.3 | 0.5 | V | 50 |
| V_{OLV} | Quiet Output Minimum Dynamic V_{OL} | 3.3 | -0.3 | -0.5 | V | 50 |
| V_{IHD} | Minimum HIGH Level Dynamic Input Voltage | 3.3 | | 2.0 | V | 50 |
| V_{ILD} | Maximum LOW Level Dynamic Input Voltage | 3.3 | | 0.8 | V | 50 |

Note 3: (Input $t_r = t_f = 3$ ns)

AC Electrical Characteristics

| Symbol | Parameter | V _{CC} (V) | T _A = +25°C | | | T _A = -40°C to +85°C | | Units | C _L (pF) |
|-------------------|--|------------------------|------------------------|------|------|---------------------------------|------|-------|---------------------|
| | | | Min | Typ | Max | Min | Max | | |
| t _{PLH} | Propagation Delay Time | 2.7 | | 7.6 | 14.5 | 1.0 | 17.5 | ns | 15 |
| t _{PHL} | CP to Q _n | | | 10.1 | 18.0 | 1.0 | 21.0 | | 50 |
| | | 3.3 ± 0.3 | | 5.9 | 9.3 | 1.0 | 11.0 | | 15 |
| | | | | 8.4 | 12.8 | 1.0 | 14.5 | | 50 |
| t _{PHL} | Propagation Delay MR to Q _n | 2.7 | | 7.9 | 15.0 | 1.0 | 18.5 | ns | 15 |
| | | | | 10.4 | 18.5 | 1.0 | 22.0 | | 50 |
| | | 3.3 ± 0.3 | | 6.2 | 9.7 | 1.0 | 11.5 | | 15 |
| | | | | 8.7 | 13.2 | 1.0 | 15.0 | | 50 |
| t _S | Setup Time D _n to CP | 2.7 | 7.5 | | | 8.5 | | ns | |
| | | 3.3 ± 0.3 | 5.0 | | | 6.0 | | | |
| t _H | Hold Time D _n to CP | 2.7 | 0 | | | 0 | | ns | |
| | | 3.3 ± 0.3 | 0 | | | 0 | | | |
| t _{REC} | Removal Time MR to CP | 2.7 | 4.5 | | | 4.5 | | ns | |
| | | 3.3 ± 0.3 | 3.0 | | | 3.0 | | | |
| t _W | Clock Pulse Width | 2.7 | 6.5 | | | 7.5 | | ns | |
| | | 3.3 ± 0.3 | 5.0 | | | 5.0 | | | |
| t _W | MR Pulse Width | 2.7 | 6.5 | | | 7.5 | | ns | |
| | | 3.3 ± 0.3 | 5.0 | | | 5.0 | | | |
| f _{MAX} | Maximum Clock Frequency | 2.7 | 65 | 130 | | 55 | | MHz | 15 |
| | | | 45 | 60 | | 40 | | | 50 |
| | | 3.3 ± 0.3 | 115 | 180 | | 95 | | | 15 |
| | | | 65 | 95 | | 55 | | | 50 |
| t _{OSLH} | Output to Output | 2.7 | | | 1.5 | | 1.5 | ns | 50 |
| t _{OSHL} | Skew (Note 4) | 3.3 | | | 1.5 | | 1.5 | | |

Note 4: Parameter guaranteed by design. t_{OSLH} = |t_{PLHm} - t_{PLHn}|, t_{OSHL} = |t_{PHLm} - t_{PHLn}|

Capacitance

| Symbol | Parameter | T _A = +25°C | | | T _A = -40°C to +85°C | | Units |
|-----------------|--|------------------------|-----|-----|---------------------------------|-----|-------|
| | | Min | Typ | Max | Min | Max | |
| C _{IN} | Input Capacitance | | 4 | 10 | | 10 | pF |
| C _{PD} | Power Dissipation Capacitance (Note 5) | | 29 | | | | pF |

Note 5: C_{PD} is defined as the value of the internal equivalent capacitance which is calculated from the operating current consumption without load.

$$\text{Average operating current can be obtained by the equation: } I_{CC(\text{opr})} = \frac{C_{PD} \times V_{CC} \times f_{IN} + I_{CC}}{4 \text{ (per F/F)}}$$

Physical Dimensions inches (millimeters) unless otherwise noted

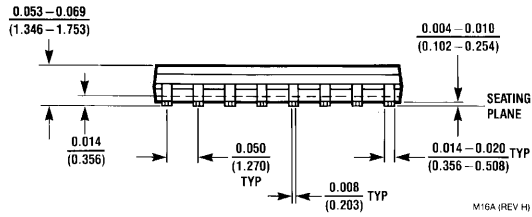
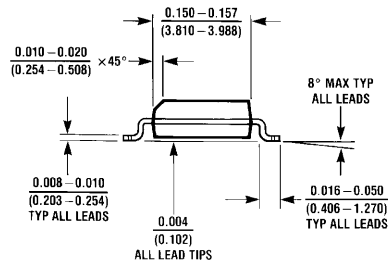
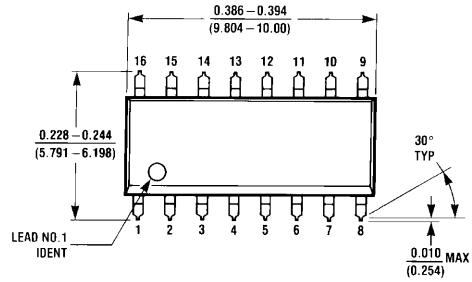

**16-Lead Small Outline Integrated Circuit (SOIC), JEDEC MS-012, 0.150" Narrow
Package Number M16A**

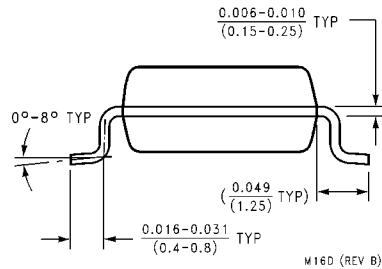
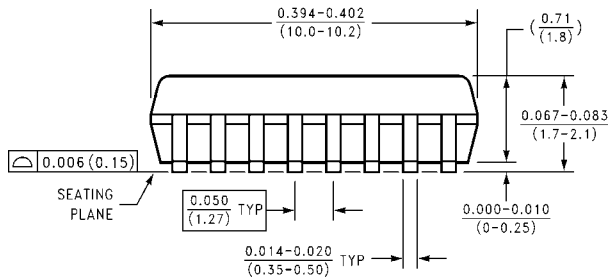
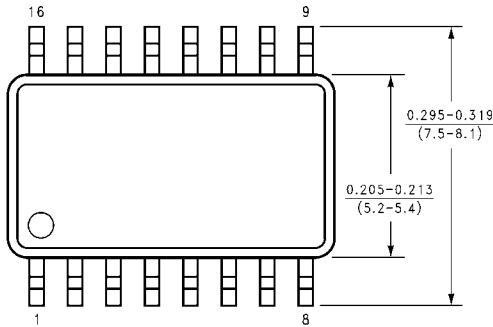

**16-Lead Small Outline Package (SOP), EIAJ TYPE II, 5.3mm Wide
Package Number M16D**

Physical Dimensions inches (millimeters) unless otherwise noted (Continued)

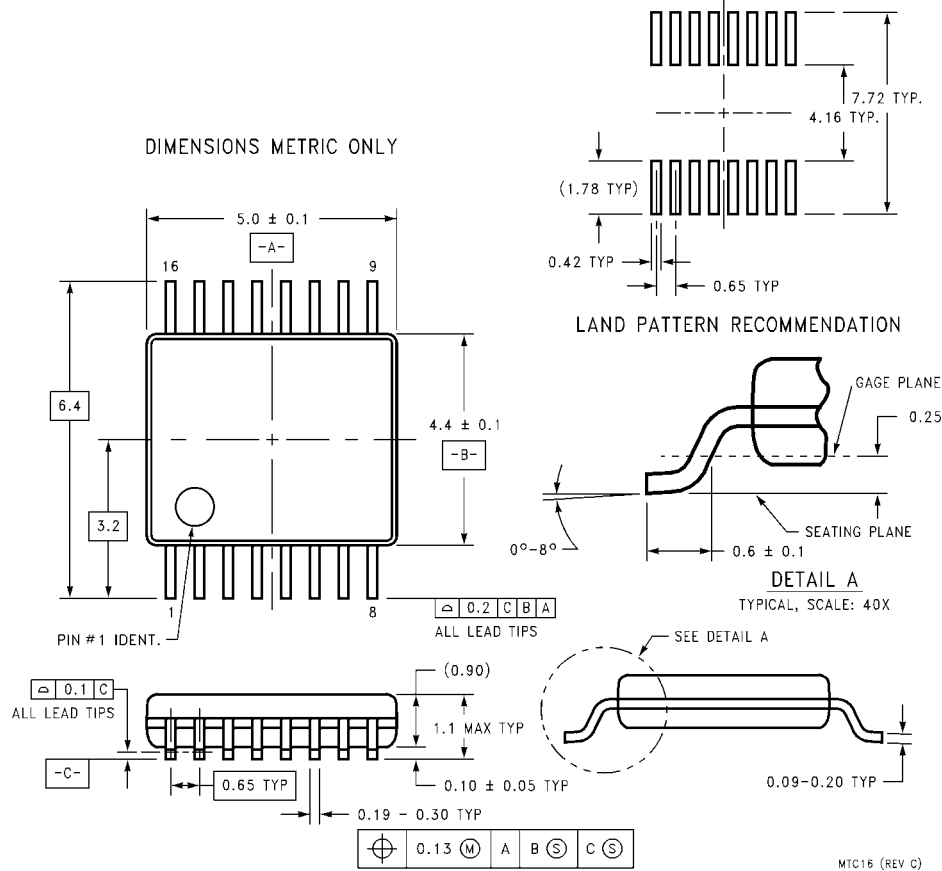

**16-Lead Thin Shrink Small Outline Package (TSSOP), JEDEC MO-153, 4.4mm Wide
Package Number MTC16**

LIFE SUPPORT POLICY

FAIRCHILD'S PRODUCTS ARE NOT AUTHORIZED FOR USE AS CRITICAL COMPONENTS IN LIFE SUPPORT DEVICES OR SYSTEMS WITHOUT THE EXPRESS WRITTEN APPROVAL OF THE PRESIDENT OF FAIRCHILD SEMICONDUCTOR CORPORATION. As used herein:

1. Life support devices or systems are devices or systems which, (a) are intended for surgical implant into the body, or (b) support or sustain life, and (c) whose failure to perform when properly used in accordance with instructions for use provided in the labeling, can be reasonably expected to result in a significant injury to the user.
2. A critical component in any component of a life support device or system whose failure to perform can be reasonably expected to cause the failure of the life support device or system, or to affect its safety or effectiveness.

www.fairchildsemi.com