

74VCX00

Low Voltage Quad 2-Input NAND Gate with 3.6V Tolerant Inputs and Outputs

General Description

The VCX00 contains four 2-input NAND gates. This product is designed for low voltage (1.65V to 3.6V) V_{CC} applications with I/O compatibility up to 3.6V.

The VCX00 is fabricated with an advanced CMOS technology to achieve high-speed operation while maintaining low CMOS power dissipation.

Features

- 1.65V to 3.6V V_{CC} supply operation
- 3.6V tolerant inputs and outputs
- t_{PD}
 - 2.8 ns max for 3.0V to 3.6V V_{CC}
 - 3.7 ns max for 2.3V to 2.7V V_{CC}
 - 7.4 ns max for 1.65V to 1.95V V_{CC}
- Power-off high impedance inputs and outputs
- Static Drive (I_{OH}/I_{OL})
 - ± 24 mA @ 3.0V V_{CC}
 - ± 18 mA @ 2.3V V_{CC}
 - ± 6 mA @ 1.65V V_{CC}
- Uses patented Quiet Series™ noise/EMI reduction circuitry
- Latchup performance exceeds 300 mA
- ESD performance:
 - Human body model > 2000V
 - Machine model > 250V

Ordering Code:

Order Number	Package Number	Package Description
74VCX00M	M14A	14-Lead Small Outline Integrated Circuit (SOIC), JEDEC MS-120, 0.150" Narrow
74VCX00MTC	MTC14	14-Lead Thin Shrink Small Outline Package (TSSOP), JEDEC MO-153, 4.4mm Wide

Devices also available in Tape and Reel. Specify by appending the suffix letter "X" to the ordering code.

Logic Symbol

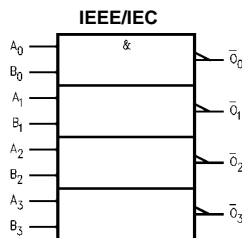

Connection Diagram

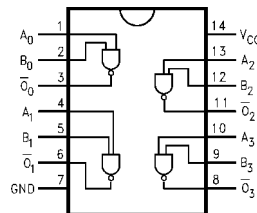

Pin Descriptions

Pin Names	Description
A_n, B_n	Inputs
\bar{O}_n	Outputs

Quiet Series™ is a trademark of Fairchild Semiconductor Corporation.

Absolute Maximum Ratings (Note 1)		Recommended Operating Conditions (Note 3)	
Supply Voltage (V_{CC})	-0.5V to +4.6V	Power Supply	
DC Input Voltage (V_I)	-0.5V to +4.6V	Operating	1.65V to 3.6V
Output Voltage (V_O)		Data Retention Only	1.2V to 3.6V
HIGH or LOW State (Note 2)	-0.5V to $V_{CC} + 0.5V$	Input Voltage	-0.3V to 3.6V
$V_{CC} = 0V$	-0.5V to +4.6V	Output Voltage (V_O)	
DC Input Diode Current (I_{IK})		HIGH or LOW State	0V to V_{CC}
$V_I < 0V$	-50 mA	Output Current in I_{OH}/I_{OL}	
DC Output Diode Current (I_{OK})		$V_{CC} = 3.0V$ to 3.6V	± 24 mA
$V_O < 0V$	-50 mA	$V_{CC} = 2.3V$ to 2.7V	± 18 mA
$V_O > V_{CC}$	+50 mA	$V_{CC} = 1.65V$ to 2.3V	± 6 mA
DC Output Source/Sink Current (I_{OL}/I_{OL})	± 50 mA	Free Air Operating Temperature (T_A)	-40°C to +85°C
DC V_{CC} or Ground Current per Supply Pin (I_{CC} or Ground)	± 100 mA	Minimum Input Edge Rate ($\Delta t/\Delta V$)	
Storage Temperature Range (T_{stg})	-65°C to +150°C	$V_{IN} = 0.8V$ to 2.0V, $V_{CC} = 3.0V$	10 ns/V

Note 1: The Absolute Maximum Ratings are those values beyond which the safety of the device cannot be guaranteed. The device should not be operated at these limits. The parametric values defined in the Electrical Characteristics tables are not guaranteed at the Absolute Maximum Ratings. The "Recommended Operating Conditions" table will define the conditions for actual device operation.

Note 2: I_O Absolute Maximum Rating must be observed.

Note 3: Floating or unused inputs must be held HIGH or LOW

DC Electrical Characteristics (2.7V < $V_{CC} \leq 3.6V$)

Symbol	Parameter	Conditions	V_{CC} (V)	Min	Max	Units
V_{IH}	HIGH Level Input Voltage		2.7-3.6	2.0		V
V_{IL}	LOW Level Input Voltage		2.7-3.6		0.8	V
V_{OH}	HIGH Level Output Voltage	$I_{OH} = -100 \mu A$ $I_{OH} = -12 mA$ $I_{OH} = -18 mA$ $I_{OH} = -24 mA$	2.7-3.6 2.7 3.0 3.0	$V_{CC} - 0.2$ 2.2 2.4 2.2		V
V_{OL}	LOW Level Output Voltage	$I_{OL} = 100 \mu A$ $I_{OL} = 12 mA$ $I_{OL} = 18 mA$ $I_{OL} = 24 mA$	2.7-3.6 2.7 3.0 3.0		0.2 0.4 0.4 0.55	V
I_I	Input Leakage Current	$0 \leq V_I \leq 3.6V$	2.7-3.6		± 5.0	μA
I_{OFF}	Power-Off Leakage Current	$0 \leq (V_I, V_O) \leq 3.6V$	0		10	μA
I_{CC}	Quiescent Supply Current	$V_I = V_{CC}$ or GND $V_{CC} \leq V_I \leq 3.6V$	2.7-3.6 2.7-3.6		20 ± 20	μA
ΔI_{CC}	Increase in I_{CC} per Input	$V_{IH} = V_{CC} - 0.6V$	2.7-3.6		750	μA

DC Electrical Characteristics ($2.3V \leq V_{CC} \leq 2.7V$)								
Symbol	Parameter	Conditions	V_{CC} (V)	Min	Max	Units		
V_{IH}	HIGH Level Input Voltage		2.3–2.7	1.6		V		
V_{IL}	LOW Level Input Voltage		2.3–2.7		0.7	V		
V_{OH}	HIGH Level Output Voltage	$I_{OH} = -100 \mu A$ $I_{OH} = -6 \text{ mA}$ $I_{OH} = -12 \text{ mA}$ $I_{OH} = -18 \text{ mA}$	2.3–2.7 2.3 2.3 2.3	$V_{CC} - 0.2$ 2.0 1.8 1.7		V		
V_{OL}	LOW Level Output Voltage	$I_{OL} = 100 \mu A$ $I_{OL} = 12 \text{ mA}$ $I_{OL} = 18 \text{ mA}$	2.3–2.7 2.3 2.3		0.2 0.4 0.6	V		
I_I	Input Leakage Current	$0 \leq V_I \leq 3.6V$	2.3–2.7		± 5.0	μA		
I_{OFF}	Power-Off Leakage Current	$0 \leq (V_I, V_O) \leq 3.6V$	0		10	μA		
I_{CC}	Quiescent Supply Current	$V_I = V_{CC}$ or GND $V_{CC} \leq V_I \leq 3.6V$	2.3–2.7 2.3–2.7		20 ± 20	μA		
DC Electrical Characteristics ($1.65V \leq V_{CC} < 2.3V$)								
Symbol	Parameter	Conditions	V_{CC} (V)	Min	Max	Units		
V_{IH}	HIGH Level Input Voltage		1.65–2.3	$0.65 \times V_{CC}$		V		
V_{IL}	LOW Level Input Voltage		1.65–2.3		$0.35 \times V_{CC}$	V		
V_{OH}	HIGH Level Output Voltage	$I_{OH} = -100 \mu A$ $I_{OH} = -6 \text{ mA}$	1.65–2.3 1.65	$V_{CC} - 0.2$ 1.25		V		
V_{OL}	LOW Level Output Voltage	$I_{OL} = 100 \mu A$ $I_{OL} = 6 \text{ mA}$	1.65–2.3 1.65		0.2 0.3	V		
I_I	Input Leakage Current	$0 \leq V_I \leq 3.6V$	1.65–2.3		± 5.0	μA		
I_{OFF}	Power-Off Leakage Current	$0 \leq (V_I, V_O) \leq 3.6V$	0		10	μA		
I_{CC}	Quiescent Supply Current	$V_I = V_{CC}$ or GND $V_{CC} \leq V_I \leq 3.6V$	1.65–2.3 1.65–2.3		20 ± 20	μA		
AC Electrical Characteristics (Note 4)								
Symbol	Parameter	$T_A = -40^\circ C$ to $+85^\circ C$, $C_L = 30pF$, $R_L = 500\Omega$						Units
		$V_{CC} = 3.3V \pm 0.3V$		$V_{CC} = 2.5V \pm 0.2V$		$V_{CC} = 1.8V \pm 0.15V$		
		Min	Max	Min	Max	Min	Max	
t_{PHL}	Propagation Delay	0.6	2.8	0.8	3.7	1.0	7.4	ns
t_{PLH}								
t_{OSHL}	Output to Output Skew (Note 5)		0.5		0.5		0.75	ns
t_{OSLH}								
Note 4: For $C_L = 50 \text{ pF}$, add approximately 300 ps to the AC maximum specification								
Note 5: Skew is defined as the absolute value of the difference between the actual propagation delay for any two separate outputs of the same device. The specification applies to any outputs switching in the same direction, either HIGH-to-LOW (t_{OSHL}) or LOW-to-HIGH (t_{OSLH}).								

Dynamic Switching Characteristics

Symbol	Parameter	Conditions	V _{CC} (V)	T _A = 25°C	Unit
				Typical	
V _{OLP}	Quiet Output Dynamic Peak V _{OL}	C _L = 30 pF, V _{IH} = V _{CC} , V _{IL} = 0V	1.8	0.25	V
			2.5	0.6	
			3.3	0.8	
V _{OLV}	Quiet Output Dynamic Valley V _{OL}	C _L = 30 pF, V _{IH} = V _{CC} , V _{IL} = 0V	1.8	-0.25	V
			2.5	-0.6	
			3.3	-0.8	
V _{OHV}	Quiet Output Dynamic Valley V _{OH}	C _L = 30 pF, V _{IH} = V _{CC} , V _{IL} = 0V	1.8	1.5	V
			2.5	1.9	
			3.3	2.2	

Capacitance

Symbol	Parameter	Conditions	T _A = +25°C	Units
			Typical	
C _{IN}	Input Capacitance	V _I = 0V or V _{CC} , V _{CC} = 1.8V, 2.5V or 3.3V	6	pF
C _{OUT}	Output Capacitance	V _I = 0V or V _{CC} , V _{CC} = 1.8V, 2.5V or 3.3V	7	pF
C _{PD}	Power Dissipation Capacitance	V _I = 0V or V _{CC} , f = 10 MHz, V _{CC} = 1.8V, 2.5V or 3.3V	20	pF

AC Loading and Waveforms

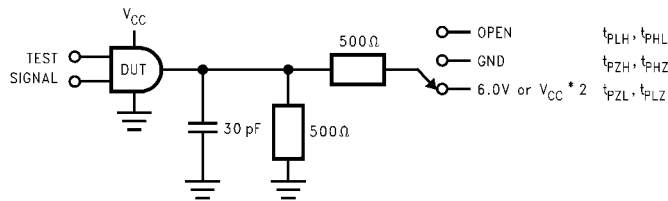

FIGURE 1. AC Test Circuit

TEST	SWITCH
t _{PLH} , t _{PHL}	Open

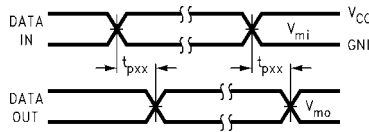
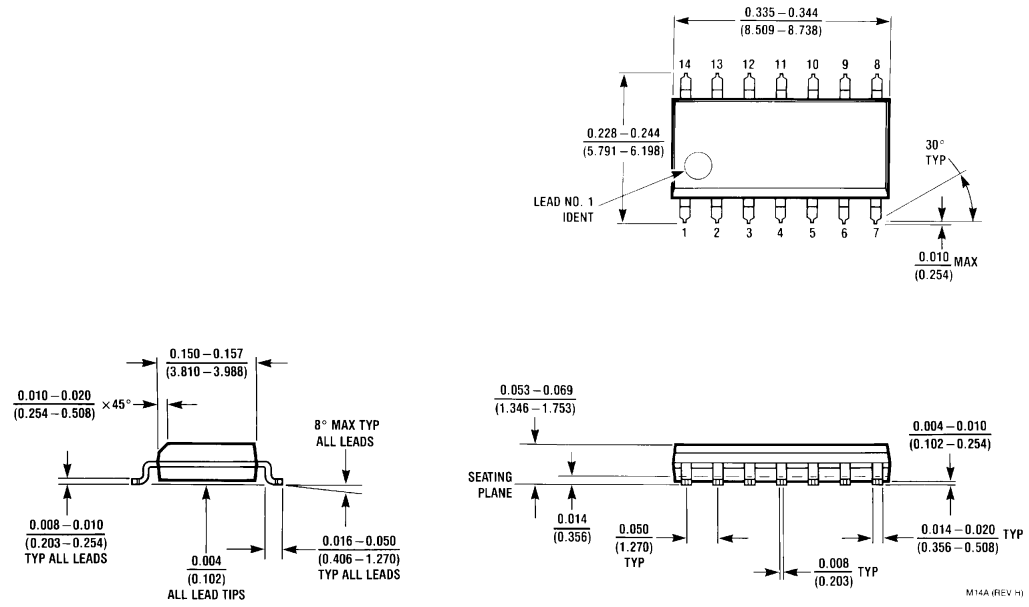

FIGURE 2. Waveform for Inverting and Non-inverting Functions

Symbol	V _{CC}		
	3.3V ± 0.3V	2.5V ± 0.2V	1.8V ± 0.15V
V _{mi}	1.5V	V _{CC} /2	V _{CC} /2
V _{mo}	1.5V	V _{CC} /2	V _{CC} /2

Physical Dimensions inches (millimeters) unless otherwise noted



**14-Lead Small Outline Integrated Circuit (SOIC), JEDEC MS-120, 0.150" Narrow
Package Number M14A**

M14A (REV H)

Physical Dimensions inches (millimeters) unless otherwise noted (Continued)

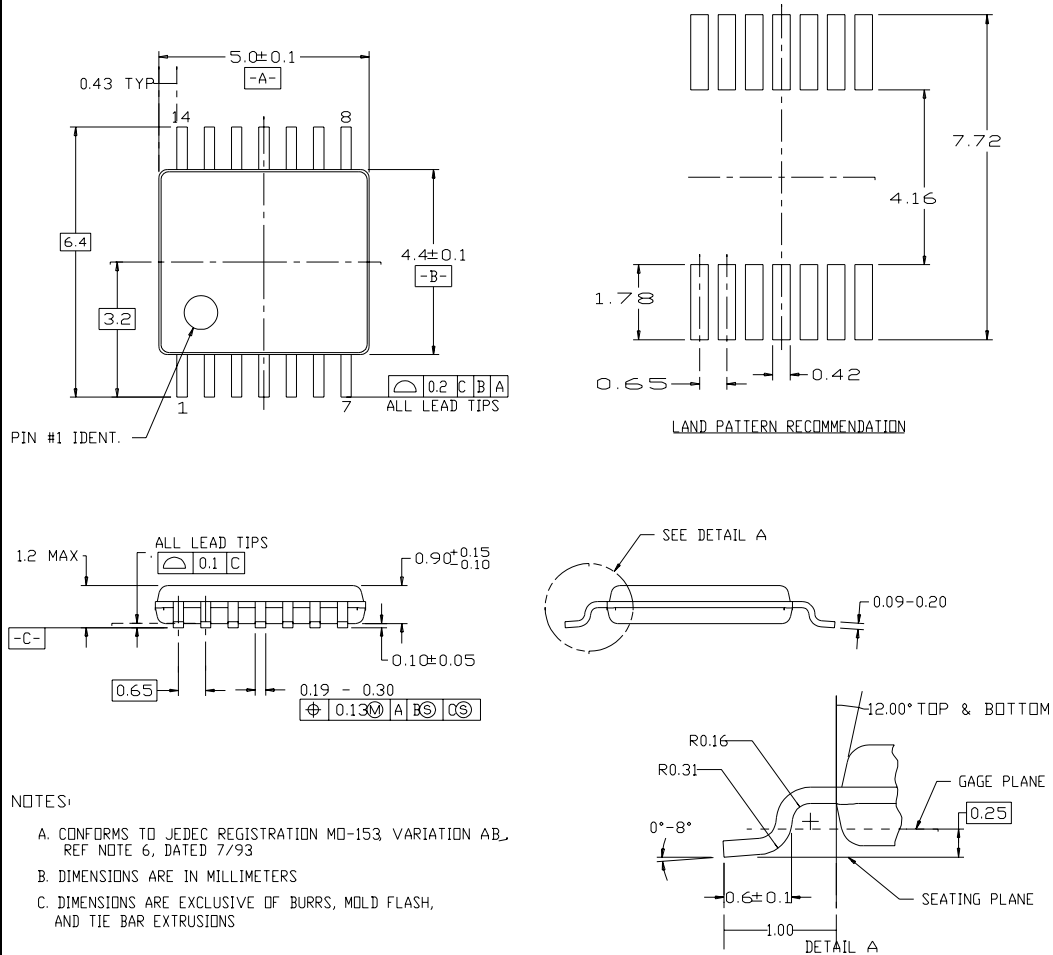

NOTES:

- A. CONFORMS TO JEDEC REGISTRATION MO-153 VARIATION AB, REF NOTE 6, DATED 7/93
- B. DIMENSIONS ARE IN MILLIMETERS
- C. DIMENSIONS ARE EXCLUSIVE OF BURRS, MOLD FLASH, AND TIE BAR EXTRUSIONS

14-Lead Thin Shrink Small Outline Package (TSSOP), JEDEC MO-153, 4.4mm Wide Package Number MTC14

Fairchild does not assume any responsibility for use of any circuitry described, no circuit patent licenses are implied and Fairchild reserves the right at any time without notice to change said circuitry and specifications.

LIFE SUPPORT POLICY

FAIRCHILD'S PRODUCTS ARE NOT AUTHORIZED FOR USE AS CRITICAL COMPONENTS IN LIFE SUPPORT DEVICES OR SYSTEMS WITHOUT THE EXPRESS WRITTEN APPROVAL OF THE PRESIDENT OF FAIRCHILD SEMICONDUCTOR CORPORATION. As used herein:

1. Life support devices or systems are devices or systems which, (a) are intended for surgical implant into the body, or (b) support or sustain life, and (c) whose failure to perform when properly used in accordance with instructions for use provided in the labeling, can be reasonably expected to result in a significant injury to the user.
2. A critical component in any component of a life support device or system whose failure to perform can be reasonably expected to cause the failure of the life support device or system, or to affect its safety or effectiveness.

www.fairchildsemi.com