

## 74VHC161284 IEEE 1284 Transceiver

### General Description

The VHC161284 contains eight bidirectional data buffers and eleven control/status buffers to implement a full IEEE 1284 compliant interface. The device supports the IEEE 1284 standard and is intended to be used in Extended Capabilities Port mode (ECP). The pinout allows for easy connection from the Peripheral (A-side) to the Host (cable side).

Outputs on the cable side can be configured to be either open drain or high drive ( $\pm 14$  mA). The pull-up and pull-down series termination resistance of these outputs on the cable side is optimized to drive an external cable. In addition, all inputs (except HLH) and outputs on the cable side contain internal pull-up resistors connected to the  $V_{CC}$  supply to provide proper termination and pull-ups for open drain mode.

Outputs on the Peripheral side are standard LOW-drive CMOS outputs. The DIR input controls data flow on the  $A_1$ – $A_8$ / $B_1$ – $B_8$  transceiver pins.

### Features

- Supports IEEE 1284 Level 1 and Level 2 signaling standards for bidirectional parallel communications between personal computers and printing peripherals
- Replaces the function of two (2) 74ACT1284 devices
- All inputs have hysteresis to provide noise margin
- B and Y output resistance optimized to drive external cable
- B and Y outputs in high impedance mode during power down
- Inputs and outputs on cable side have internal pull-up resistors
- Flow-through pin configuration allows easy interface between the Peripheral and Host

### Ordering Code:

Ordering Number	Package Number	Package Description
74VHC161284MEA	MS48A	48-Lead Small Shrink Outline Package (SSOP), JEDEC MO-118, 0.300 Wide
74VHC161284MTD	MTD48	48-Lead Thin Shrink Small Outline Package (TSSOP), JEDEC MO-153, 6.1mm Wide

Surface mount packages are also available on Tape and Reel. Specify by appending the suffix letter "X" to the ordering code.

### Logic Symbol

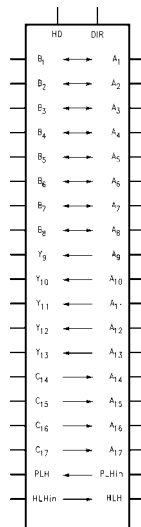

### Connection Diagram

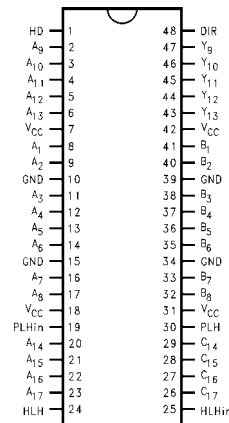

**Pin Descriptions**

Pin Names	Description
HD	HIGH Drive Enable Input (Active HIGH)
DIR	Direction Control Input
A <sub>1</sub> -A <sub>8</sub>	Inputs or Outputs
B <sub>1</sub> -B <sub>8</sub>	Inputs or Outputs
A <sub>9</sub> -A <sub>13</sub>	Inputs
Y <sub>9</sub> -Y <sub>13</sub>	Outputs
A <sub>14</sub> -A <sub>17</sub>	Outputs
C <sub>14</sub> -C <sub>17</sub>	Inputs
PLH <sub>IN</sub>	Peripheral Logic HIGH Input
PLH	Peripheral Logic HIGH Output
HLH <sub>IN</sub>	Host Logic HIGH Input
HLH	Host Logic HIGH Output

**Truth Table**

Inputs		Outputs
DIR	HD	
L	L	B <sub>1</sub> -B <sub>8</sub> Data to A <sub>1</sub> -A <sub>8</sub> , and A <sub>9</sub> -A <sub>13</sub> Data to Y <sub>9</sub> -Y <sub>13</sub> (Note 1) C <sub>14</sub> -C <sub>17</sub> Data to A <sub>14</sub> -A <sub>17</sub> PLH Open Drain Mode
L	H	B <sub>1</sub> -B <sub>8</sub> Data to A <sub>1</sub> -A <sub>8</sub> , and A <sub>9</sub> -A <sub>13</sub> Data to Y <sub>9</sub> -Y <sub>13</sub> C <sub>14</sub> -C <sub>17</sub> Data to A <sub>14</sub> -A <sub>17</sub>
H	L	A <sub>1</sub> -A <sub>8</sub> Data to B <sub>1</sub> -B <sub>8</sub> (Note 2) A <sub>9</sub> -A <sub>13</sub> Data to Y <sub>9</sub> -Y <sub>13</sub> (Note 1) C <sub>14</sub> -C <sub>17</sub> Data to A <sub>14</sub> -A <sub>17</sub> PLH Open Drain Mode
H	H	A <sub>1</sub> -A <sub>8</sub> Data to B <sub>1</sub> -B <sub>8</sub> A <sub>9</sub> -A <sub>13</sub> Data to Y <sub>9</sub> -Y <sub>13</sub> C <sub>14</sub> -C <sub>17</sub> Data to A <sub>14</sub> -A <sub>17</sub>

**Note 1:** Y<sub>9</sub>-Y<sub>13</sub> Open Drain Outputs

**Note 2:** B<sub>1</sub>-B<sub>8</sub> Open Drain Outputs

**Logic Diagram**

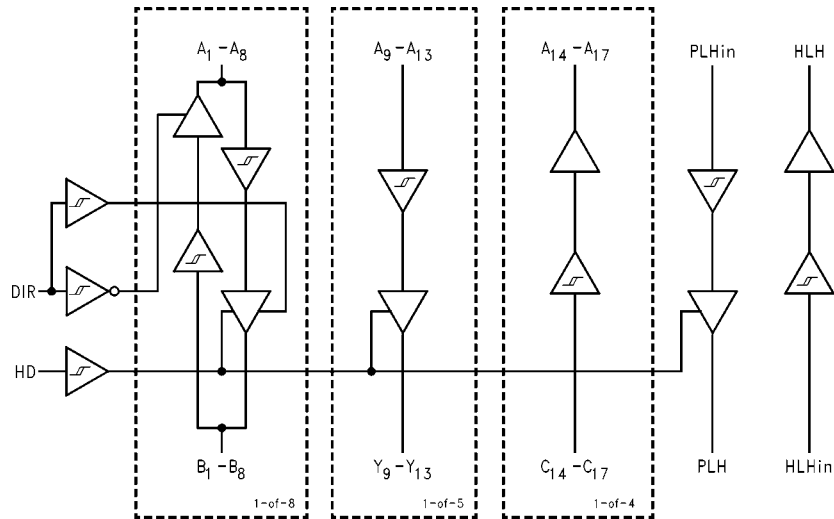

Absolute Maximum Ratings (Note 3)		Output Diode Current ( $I_{OK}$ )	
Supply Voltage		$A_1-A_8, A_{14}-A_{17}, HLH$	$\pm 50$ mA
$V_{CC}$	-0.5V to + 7.0V	$B_1-B_8, Y_9-Y_{13}, PLH$	-50 mA
Input Voltage ( $V_I$ ) (Note 4)		DC Continuous $V_{CC}$ or	
$A_1-A_{13}, PLH_{IN}, DIR, HD$	-0.5V to $V_{CC} + 0.5V$	Ground Current	$\pm 200$ mA
$B_1-B_8, C_{14}-C_{17}, HLH_{IN}$	-0.5V to + 5.5V (DC)	Storage Temperature	-65°C to + 150°C
$B_1-B_8, C_{14}-C_{17}, HLH_{IN}$	-2.0V to + 7.0V *	ESD (HBM) Last Passing	
	*40 ns Transient	Voltage	2000V
Output Voltage ( $V_O$ )		<b>Recommended Operating Conditions</b>	
$A_1-A_8, A_{14}-A_{17}, HLH$	-0.5V to $V_{CC} + 0.5V$	Supply Voltage	4.5V to 5.5V
$B_1-B_8, Y_9-Y_{13}, PLH$	-0.5V to + 5.5V (DC)	$V_{CC}$	
$B_1-B_8, Y_9-Y_{13}, PLH$	-2.0V to + 7.0V*	DC Input Voltage ( $V_I$ )	0V to $V_{CC}$
	*40 ns Transient	Open Drain Voltage ( $V_O$ )	0V to 5.5V
DC Output Current ( $I_O$ )		Operating Temperature ( $T_A$ )	-40°C to + 85°C
$A_1-A_8, HLH$	$\pm 25$ mA	<b>Note 3:</b> Absolute Maximum continuous ratings are those values beyond which damage to the device may occur. Exposure to these indicated may adversely affect device reliability. Functional operation under absolute maximum rated conditions is not implied.	
$B_1-B_8, Y_9-Y_{13}$	$\pm 50$ mA	<b>Note 4:</b> Either voltage limit or current limit is sufficient to protect inputs.	
PLH (Output LOW)	84 mA		
PLH (Output HIGH)	-50 mA		
Input Diode Current ( $I_{IK}$ ) (Note 4)			
DIR, HD, $A_9-A_{13}$ ,			
PLH, HLH, $C_{14}-C_{17}$	-20 mA		

## DC Electrical Characteristics

Symbol	Parameter	$V_{CC}$ (V)	$T_A = -40^\circ\text{C to } +85^\circ\text{C}$		Units	Conditions	
			Guaranteed Limits				
$V_{IK}$	Input Clamp Diode Voltage	3.0	-1.2		V	$I_I = -18$ mA	
$V_{IH}$	Minimum HIGH Level Input Voltage	$A_n, PLH_{IN}, DIR, HD$	4.5 - 5.5	0.7 $V_{CC}$		V	
		$B_n$	4.5 - 5.5	2.0			
		$C_n$	4.5 - 5.5	2.3			
		$HLH_{IN}$	4.5 - 5.5	2.6			
$V_{IL}$	Maximum LOW Level Input Voltage	$A_n, PLH_{IN}, DIR, HD$	4.5 - 5.5	0.3 $V_{CC}$		V	
		$B_n$	4.5 - 5.5	0.8			
		$C_n$	4.5 - 5.5	0.8			
		$HLH_{IN}$	4.5 - 5.5	1.6			
$\Delta VT$	Minimum Input Hysteresis	$A_n, PLH_{IN}, DIR, HD$	4.5 - 5.5	0.4		V	$V_T^+ - V_T^-$
		$B_n$	4.5 - 5.5	0.4			$V_T^+ - V_T^-$
		$C_n$	5.0	0.8			$V_T^+ - V_T^-$
		$HLH_{IN}$	5.0	0.3			$V_T^+ - V_T^-$
$V_{OH}$	Minimum HIGH Level Output Voltage	$A_n, HLH$	4.5	4.4		V	$I_{OH} = -50$ $\mu$ A
			4.5	3.8			$I_{OH} = -8$ mA
		$B_n, Y_n$	4.5	3.73			$I_{OH} = -14$ mA
		PLH	4.5	4.45			$I_{OH} = -500$ $\mu$ A
$V_{OL}$	Maximum LOW Level Output Voltage	$A_n, HLH$	4.5	0.1		V	$I_{OL} = 50$ $\mu$ A
			4.5	0.44			$I_{OL} = 8$ mA
		$B_n, Y_n$	4.5	0.77			$I_{OL} = 14$ mA
		PLH	4.5	0.7			$I_{OL} = 84$ mA
RD	Maximum Output Impedance	$B_1-B_8, Y_9-Y_{13}$	5.0	55		$\Omega$	(Note 5)(Note 6)
	Minimum Output Impedance	$B_1-B_8, Y_9-Y_{13}$	5.0	35		$\Omega$	(Note 5)(Note 6)
RP	Maximum Pull-Up Resistance	$B_1-B_8, Y_9-Y_{13}, C_{14}-C_{17}$	5.0	1650		$\Omega$	
	Minimum Pull-Up Resistance	$B_1-B_8, Y_9-Y_{13}, C_{14}-C_{17}$	5.0	1150		$\Omega$	
$I_{IH}$	Maximum Input Current in HIGH State	$A_9-A_{13}, PLH_{IN}, HD, DIR, HLH_{IN}$	5.5	1.0		$\mu$ A	$V_I = 5.5V$
		$C_{14}-C_{17}$	5.5	100			$V_I = 5.5V$

## DC Electrical Characteristics (Continued)

Symbol	Parameter	V <sub>CC</sub> (V)	T <sub>A</sub> = -40°C to +85°C		Units	Conditions
			Guaranteed Limits			
I <sub>IL</sub>	Maximum Input Current in LOW State	A <sub>9</sub> -A <sub>13</sub> , PLH <sub>IN</sub> , HD, DIR, HLH <sub>IN</sub>	5.5	-1.0	μA	V <sub>I</sub> = 0.0V
		C <sub>14</sub> -C <sub>17</sub>	5.5	-5.0	mA	V <sub>I</sub> = 0.0V
I <sub>OZH</sub>	Maximum Output Disable Current (HIGH)	A <sub>1</sub> -A <sub>8</sub>	5.5	20	μA	V <sub>O</sub> = 5.5V
		B <sub>1</sub> -B <sub>8</sub>	5.5	100		V <sub>O</sub> = 5.5V
I <sub>OZL</sub>	Maximum Output Disable Current (LOW)	A <sub>1</sub> -A <sub>8</sub>	5.5	-20	μA	V <sub>O</sub> = 0.0V
		B <sub>1</sub> -B <sub>8</sub>	5.5	-5.0		
I <sub>OFF</sub>	Power Down Output Leakage	B <sub>1</sub> -B <sub>8</sub> , Y <sub>9</sub> -Y <sub>13</sub> , PLH	0.0	100	μA	V <sub>O</sub> = 5.5V
I <sub>OFF</sub>	Power Down Input Leakage	C <sub>14</sub> -C <sub>17</sub> , HLH <sub>IN</sub>	0.0	100	μA	V <sub>I</sub> = 5.5V
I <sub>OFF</sub> - I <sub>CC</sub>	Power Down Leakage to V <sub>CC</sub>		0.0	250	μA	(Note 7)
I <sub>CC</sub>	Maximum Supply Current		5.5	70	mA	V <sub>I</sub> = V <sub>CC</sub> or GND

**Note 5:** Output impedance is measured with the output active LOW and active HIGH (HD = HIGH).

**Note 6:** This parameter is guaranteed but not tested, characterized only.

**Note 7:** Power-down leakage to V<sub>CC</sub> is tested by simultaneously forcing all pins on the cable-side (B<sub>1</sub>-B<sub>8</sub>, Y<sub>9</sub>-Y<sub>13</sub>, PLH, C<sub>14</sub>-C<sub>17</sub> and HLH<sub>IN</sub>) to 5.5V and measuring the resulting I<sub>CC</sub>.

AC Electrical Characteristics					
Symbol	Parameter	T <sub>A</sub> = -40°C to +85°C V <sub>CC</sub> = 4.5V – 5.5V		Units	Fig. No.
		Min	Max		
t <sub>PHL</sub>	A <sub>1</sub> –A <sub>8</sub> to B <sub>1</sub> –B <sub>8</sub>	2.0	30.0	ns	Figure 1
t <sub>PLH</sub>	A <sub>1</sub> –A <sub>8</sub> to B <sub>1</sub> –B <sub>8</sub>	2.0	30.0	ns	Figure
t <sub>PHL</sub>	B <sub>1</sub> –B <sub>8</sub> to A <sub>1</sub> –A <sub>8</sub>	2.0	30.0	ns	Figure 3
t <sub>PLH</sub>	B <sub>1</sub> –B <sub>8</sub> to A <sub>1</sub> –A <sub>8</sub>	2.0	30.0	ns	Figure 3
t <sub>PHL</sub>	A <sub>9</sub> –A <sub>13</sub> to Y <sub>9</sub> –Y <sub>13</sub>	2.0	30.0	ns	Figure 1
t <sub>PLH</sub>	A <sub>9</sub> –A <sub>13</sub> to Y <sub>9</sub> –Y <sub>13</sub>	2.0	30.0	ns	Figure
t <sub>PHL</sub>	C <sub>14</sub> –C <sub>17</sub> to A <sub>14</sub> –A <sub>17</sub>	2.0	30.0	ns	Figure 3
t <sub>PLH</sub>	C <sub>14</sub> –C <sub>17</sub> to A <sub>14</sub> –A <sub>17</sub>	2.0	30.0	ns	Figure 3
t <sub>SKEW</sub>	LH-LH or HL-HL		6.0	ns	(Note 9)
t <sub>PHL</sub>	PLH <sub>IN</sub> to PLH	2.0	30.0	ns	Figure 1
t <sub>PLH</sub>	PLH <sub>IN</sub> to PLH	2.0	30.0	ns	Figure
t <sub>PHL</sub>	HLH <sub>IN</sub> to HLH	2.0	30.0	ns	Figure 3
t <sub>PLH</sub>	HLH <sub>IN</sub> to HLH	2.0	30.0	ns	Figure 3
t <sub>PHZ</sub>	Output Disable Time	2.0	18.0	ns	Figure 7
t <sub>PLZ</sub>	DIR to A <sub>1</sub> –A <sub>8</sub>	2.0	18.0	ns	
t <sub>PZH</sub>	Output Enable Time	2.0	25.0	ns	Figure 8
t <sub>PZL</sub>	DIR to A <sub>1</sub> –A <sub>8</sub>	2.0	25.0	ns	
t <sub>PHZ</sub>	Output Disable Time	2.0	25.0	ns	Figure 9
t <sub>PLZ</sub>	DIR to B <sub>1</sub> –B <sub>8</sub>	2.0	25.0	ns	
t <sub>pEN</sub>	Output Enable Time HD to B <sub>1</sub> –B <sub>8</sub> , Y <sub>9</sub> –Y <sub>13</sub>	2.0	28.0	ns	Figure
t <sub>pDis</sub>	Output Disable Time HD to B <sub>1</sub> –B <sub>8</sub> , Y <sub>9</sub> –Y <sub>13</sub>	2.0	28.0	ns	Figure
t <sub>pEn</sub> –t <sub>pDis</sub>	Output Enable-Output Disable		20.0	ns	
t <sub>SLEW</sub>	Output Slew Rate				
t <sub>PLH</sub>	B <sub>1</sub> –B <sub>8</sub> , Y <sub>9</sub> –Y <sub>13</sub>	0.05	0.40	V/ns	Figure 5
t <sub>PHL</sub>		0.05	0.40		Figure 4
t <sub>r</sub> , t <sub>f</sub>	t <sub>RISE</sub> and t <sub>FALL</sub> B <sub>1</sub> –B <sub>8</sub> , Y <sub>9</sub> –Y <sub>13</sub> (Note 8)		120	ns	Figure 6 (Note 10)
<p><b>Note 8:</b> Open Drain</p> <p><b>Note 9:</b> t<sub>SKEW</sub> is measured for common edge output transitions and compares the measured propagation delay for a given path type.</p> <p>(i) A<sub>1</sub>–A<sub>8</sub> to B<sub>1</sub>–B<sub>8</sub>, A<sub>9</sub>–Y<sub>13</sub> to Y<sub>9</sub>–Y<sub>13</sub></p> <p>(ii) B<sub>1</sub>–B<sub>8</sub> to A<sub>1</sub>–A<sub>8</sub></p> <p>(iii) C<sub>14</sub>–C<sub>17</sub> to A<sub>14</sub>–A<sub>17</sub></p> <p><b>Note 10:</b> This parameter is guaranteed but not tested, characterized only.</p> <p><b>Note 11:</b> Pulse Generator for all pulses: Rate ≤ 1.0 MHz; Z<sub>O</sub> ≤ 50Ω; t<sub>r</sub> ≤ 2.5 ns, t<sub>f</sub> ≤ 2.5 ns.</p>					
<b>Capacitance</b> (Note 12)					
Symbol	Parameter	Typ	Units	Conditions	
C <sub>IN</sub>	Input Capacitance	5	pF	V <sub>CC</sub> = 0.0V (HD, DIR, A <sub>9</sub> –A <sub>13</sub> , C <sub>14</sub> –C <sub>17</sub> , PLH <sub>IN</sub> and HLH <sub>IN</sub> )	
C <sub>I/O</sub>	I/O Pin Capacitance	12	pF	V <sub>CC</sub> = 3.3V	
<b>Note 12:</b> Capacitance is measured at frequency = 1 MHz.					

AC Loading and Waveforms

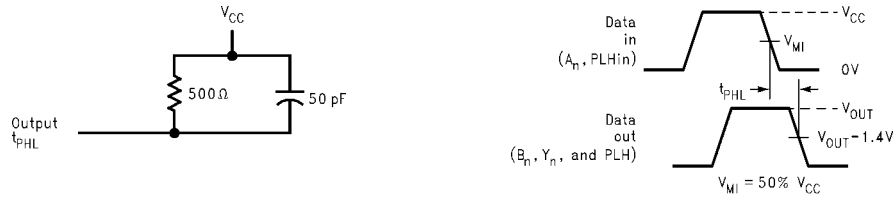

**FIGURE 1.  $t_{PHL}$  Test Load and Waveforms**  
**A<sub>1</sub>–A<sub>8</sub> to B<sub>1</sub>–B<sub>8</sub>**  
**A<sub>9</sub>–A<sub>13</sub> to Y<sub>9</sub>–Y<sub>13</sub>**  
**PLH<sub>IN</sub> to PLH**

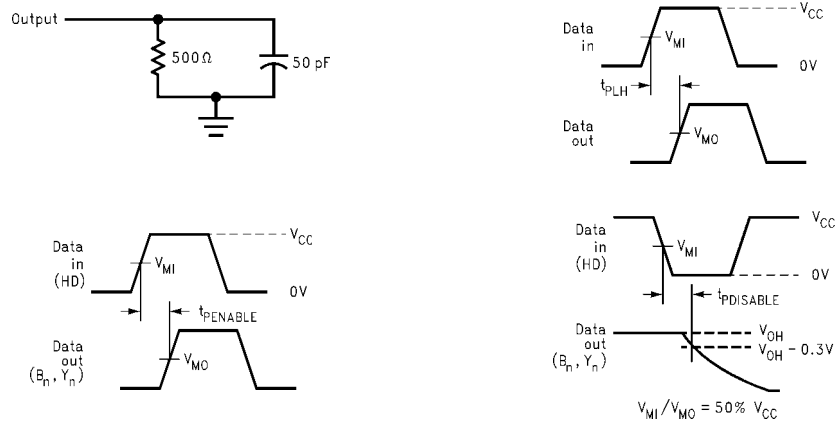
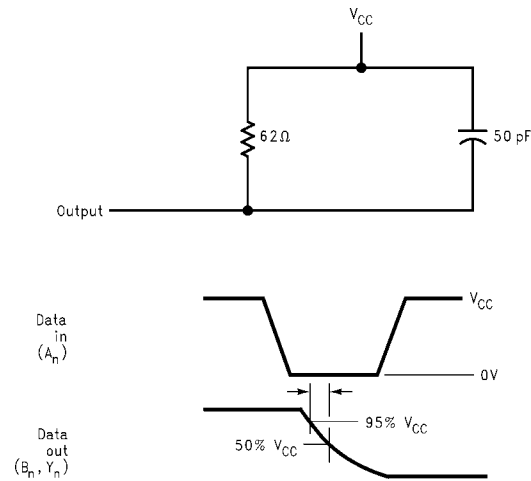

**FIGURE 2.  $t_{PLH}$ ,  $t_{pEn}$ ,  $t_{pDis}$  Test Load and Waveforms**  
**A<sub>1</sub>–A<sub>8</sub> to B<sub>1</sub>–B<sub>8</sub>, A<sub>9</sub>–A<sub>13</sub> to Y<sub>9</sub>–Y<sub>13</sub>**  
**PLH<sub>IN</sub> to PLH, HD to B<sub>1</sub>–B<sub>8</sub>, Y<sub>9</sub>–Y<sub>13</sub>, PLH**

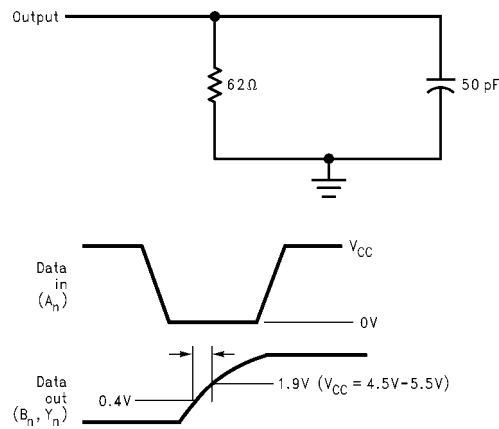

**FIGURE 3.  $t_{PHL}$ ,  $t_{PLH}$  Test Load and Waveforms**  
**B<sub>1</sub>–B<sub>8</sub> to A<sub>1</sub>–A<sub>8</sub>, C<sub>14</sub>–C<sub>17</sub> to A<sub>14</sub>–A<sub>17</sub>, HLH<sub>IN</sub> to HLH**

AC Loading and Waveforms (Continued)



**FIGURE 4.  $t_{SLEW}$  HL Test Load and Waveforms**  
**A<sub>1</sub>-A<sub>8</sub> to B<sub>1</sub>-B<sub>8</sub>**  
**A<sub>9</sub>-A<sub>13</sub> to Y<sub>9</sub>-Y<sub>13</sub>**



**FIGURE 5.  $t_{SLEW}$  LH Test Load and Waveforms**  
**A<sub>1</sub>-A<sub>8</sub> to B<sub>1</sub>-B<sub>8</sub>**  
**A<sub>9</sub>-A<sub>13</sub> to Y<sub>9</sub>-Y<sub>13</sub>**

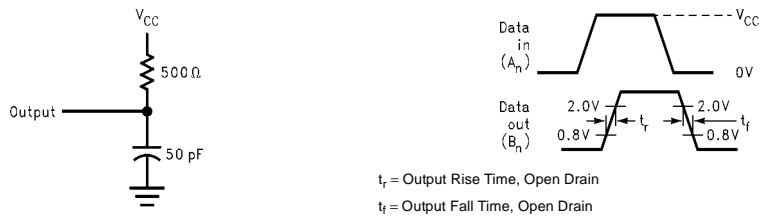

$t_r$  = Output Rise Time, Open Drain  
 $t_f$  = Output Fall Time, Open Drain

**FIGURE 6.  $t_{RISE}$  and  $t_{FALL}$  Test Load and Waveforms for Open Drain Outputs**  
**A<sub>1</sub>-A<sub>8</sub> to B<sub>1</sub>-B<sub>8</sub>, A<sub>9</sub>-A<sub>13</sub> to Y<sub>9</sub>-Y<sub>13</sub>**

AC Loading and Waveforms (Continued)

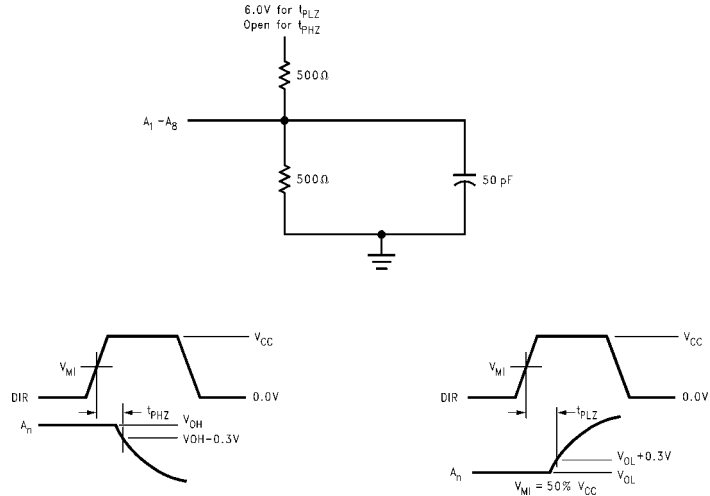

FIGURE 7.  $t_{PHZ}$  and  $t_{PLZ}$  Test Load and Waveforms, DIR to  $A_1 - A_8$

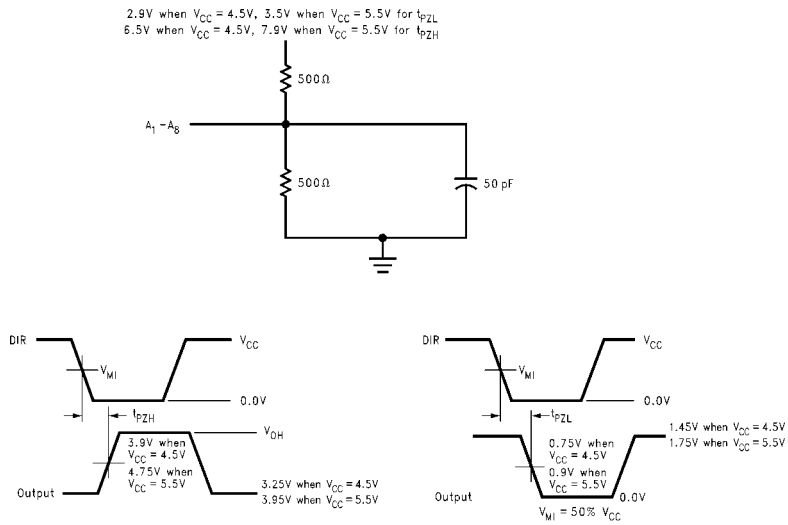

FIGURE 8.  $t_{PZH}$  and  $t_{PZL}$  Test Load and Waveforms, DIR to  $A_1 - A_8$

AC Loading and Waveforms (Continued)

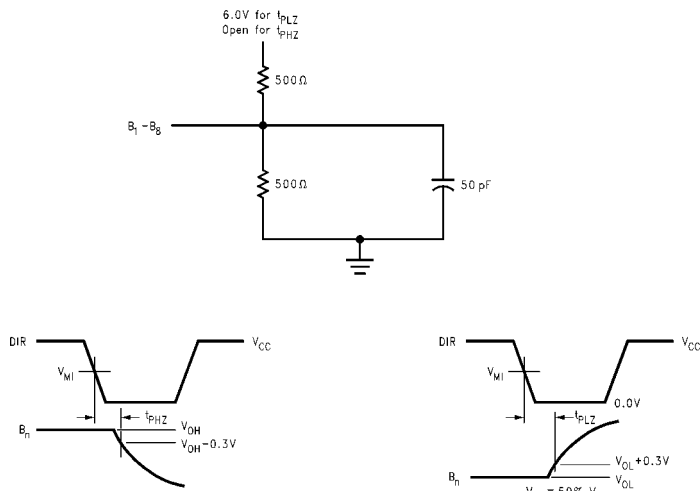
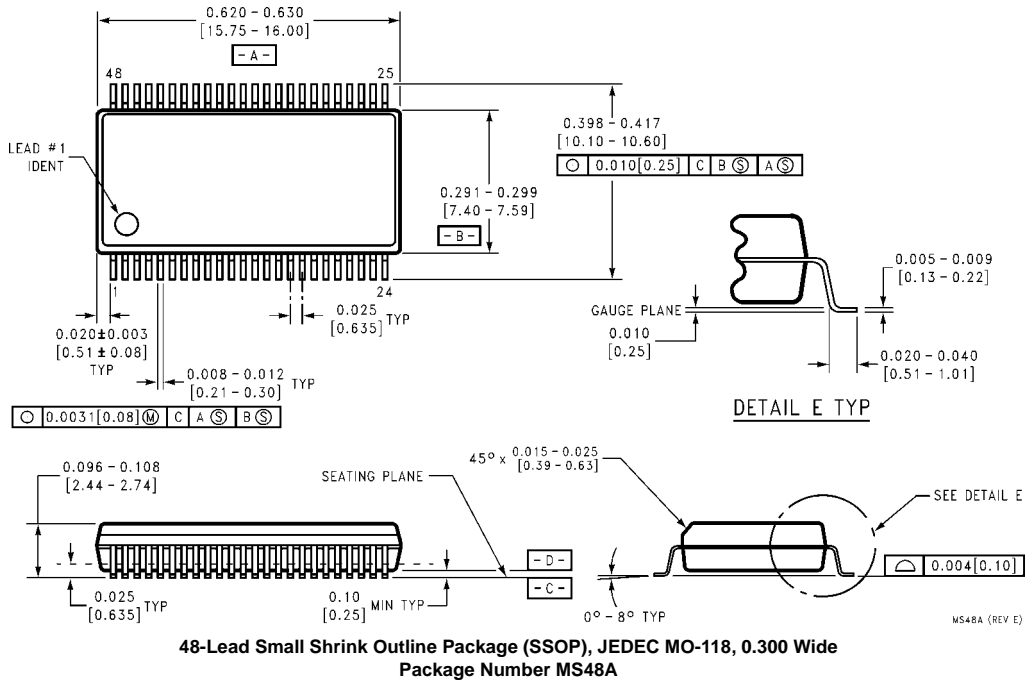

FIGURE 9.  $t_{PHZ}$  and  $t_{PLZ}$  Test Load and Waveforms, DIR to  $B_1 - B_8$

74VHC161284

**Physical Dimensions** inches (millimeters) unless otherwise noted



**Physical Dimensions** inches (millimeters) unless otherwise noted (Continued)

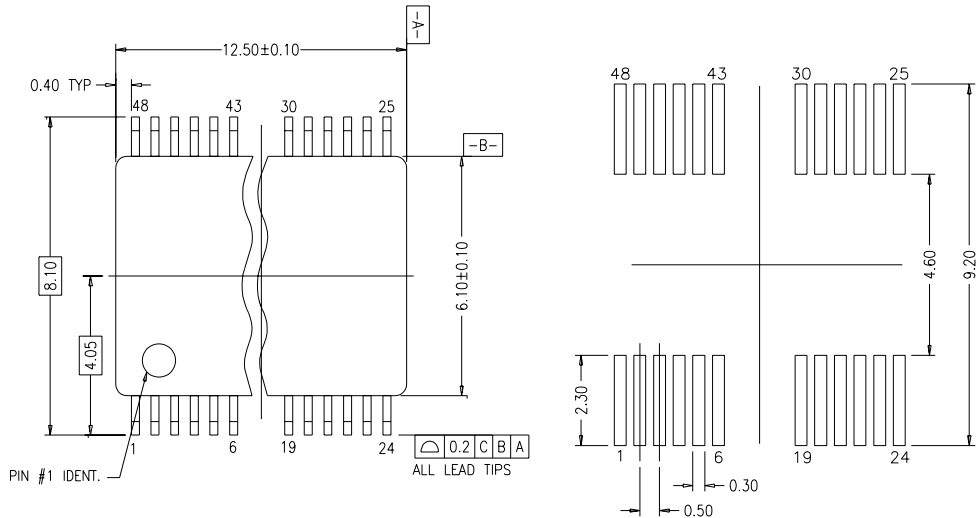

LAND PATTERN RECOMMENDATION

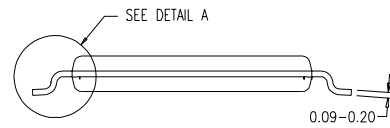
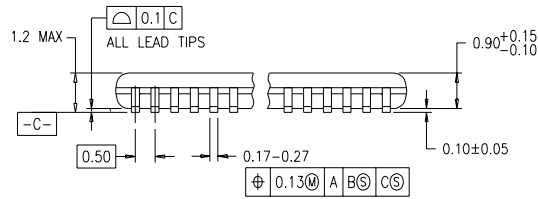

DIMENSIONS ARE IN MILLIMETERS

NOTES:

- A. CONFORMS TO JEDEC REGISTRATION MO-153, VARIATION AB, REF NOTE 6, DATE 7/93.
- B. DIMENSIONS ARE IN MILLIMETERS.
- C. DIMENSIONS ARE EXCLUSIVE OF BURRS, MOLD FLASH, AND TIE BAR EXTRUSIONS.
- D. DIMENSIONS AND TOLERANCES PER ANSI Y14.5M, 1982.

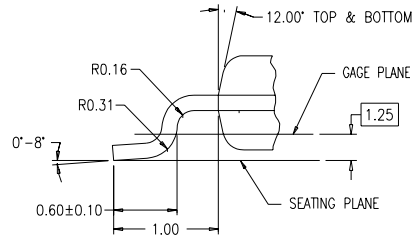

DETAIL A

MTD48REVB1

**48-Lead Thin Shrink Small Outline Package (TSSOP), JEDEC MO-153, 6.1mm Wide  
Package Number MTD48**

Fairchild does not assume any responsibility for use of any circuitry described, no circuit patent licenses are implied and Fairchild reserves the right at any time without notice to change said circuitry and specifications.

**LIFE SUPPORT POLICY**

FAIRCHILD'S PRODUCTS ARE NOT AUTHORIZED FOR USE AS CRITICAL COMPONENTS IN LIFE SUPPORT DEVICES OR SYSTEMS WITHOUT THE EXPRESS WRITTEN APPROVAL OF THE PRESIDENT OF FAIRCHILD SEMICONDUCTOR CORPORATION. As used herein:

1. Life support devices or systems are devices or systems which, (a) are intended for surgical implant into the body, or (b) support or sustain life, and (c) whose failure to perform when properly used in accordance with instructions for use provided in the labeling, can be reasonably expected to result in a significant injury to the user.
2. A critical component in any component of a life support device or system whose failure to perform can be reasonably expected to cause the failure of the life support device or system, or to affect its safety or effectiveness.

[www.fairchildsemi.com](http://www.fairchildsemi.com)