

AN6855T

High-Speed 4-bit A/D Converter

Overview

The AN6855T is a high-speed and low power dissipation 4-bit monolithic IC (A/D converter parallel type) and is suitable for high-speed data conversion and computer input data conversion such as digitizer of video band signal.

Features

- 4-bit resolution (with overflow pin attached)
- High speed maximum conversion speed 20MSPS
- Sample and hold circuits are not necessary
- Input dynamic range is 2V
- Low power dissipation : 170mW typ
- Digital outputs are TTL compatible

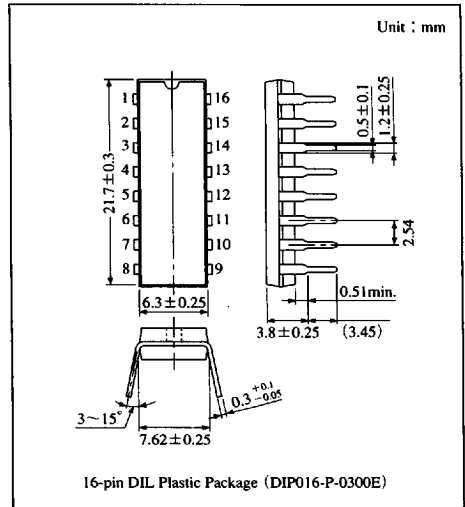

Main Characteristics ($V_{EE} = -6.0V, V_{CC} = 5.0V, T_a = -20 \text{ to } +70^\circ\text{C}$)

Parameter	Symbol	Condition	Value	Unit
Resolution	RES		4	bit
Input dynamic range	$V_{i(max)}$		2	V
Linearity error	LE	$V_{in} = 2V_{P-P}$	$\pm \frac{1}{4}$	LSB
Max conversion speed	$f_{MSPS(max)}$		20	MSPS

A/D and D/A Converters

Pin Descriptions

Pin No.	Pin name	Pin No.	Pin name
1	Digital output LSB	9	Negative supply voltage
2	Digital output 3-bit	10	Reference high level
3	Digital output 2-bit	11	Analog ground
4	Supply voltage	12	Negative supply voltage
5	Digital ground	13	Analog input
6	Digital output MSB	14	Reference low level
7	Overflow output	15	Analog ground
8	Clock input	16	Output signal reversal control

■ 6932852 0012959 5TT ■

Panasonic

■ Block Diagram

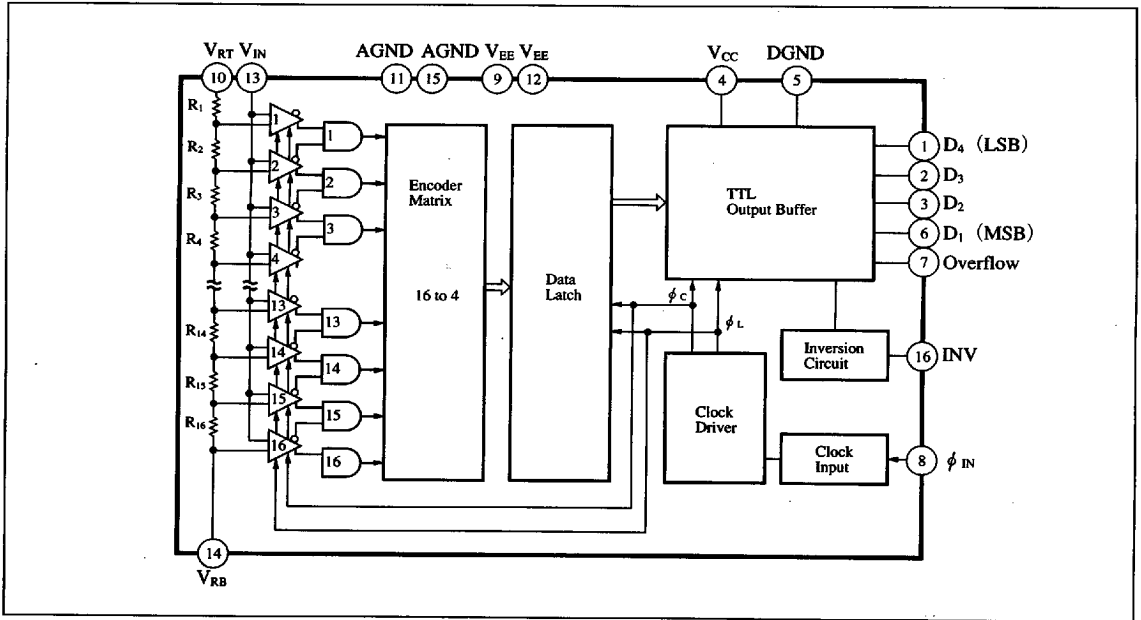

■ Absolute Maximum Ratings (Ta=25°C)

Parameter	Symbol	Rating	Unit
Supply voltage	V _{CC}	-0.3 to +5.5	V
Supply voltage	V _{EE}	-6.6 to +0.3	V
Analog input voltage	V _i	V _{EE} to +0.3	V
Digital input voltage	V _φ	-0.3 to V _{CC}	V
Reference voltage	V _{REF}	V _{EE} to +0.3	V
Power dissipation	P _D	540	mW
Operating ambient temperature	T _{OPR}	-20 to +70	°C
Storage temperature	T _{sig}	-40 to +150	°C

■ Recommended Operating Conditions

Parameter	Symbol	min	typ	max	Unit
Supply voltage	V _{CC}	4.5	5	5.5	V
	V _{EE}	-6.6	-6	-5.4	V
Reference voltage	V _{RT}	-0.1	0	+0.1	V
	V _{RB}	-2.1	-2	-1.9	V
Analog input voltage	V _i	-2.1	—	+0.1	V
Digital input voltage	V _{φH}	2.5	—	5	V
	V _{φL}	0	—	0.4	V
Digital output current	I _{OH}	-2	—	—	mA
Clock input pulse width (Clock input)	τ _H	25	—	—	ns
	τ _L	25	—	—	ns

■ 6932852 0012960 211 ■

Panasonic

■ Electrical Characteristics (Ta=25°C)

Parameter	Symbol	Condition	min	typ	max	Unit
Supply current	I_{CC}	$V_{CC}=5V, V_{EE}=-6V$	10	20	30	mA
	I_{EE}		11	17	23	mA
Reference resistance current	$I_{Bias(RT)}$	$V_{RT}=0V, V_{RB}=-2V$	0.8	1.5	2.1	mA
	$I_{Bias(RB)}$		-2.1	-1.5	-0.8	mA
Input bias current	I_{Bias}	$V_{CC}=5V, V_{EE}=-6V$	1.5	6	15	μA
Clock input current	$I_{\phi H}$	$V_{CC}=5V, V_{EE}=-6V$	0.3	0.7	2.4	mA
	$I_{\phi L}$		-1.4	-0.9	-0.6	mA
Digital output voltage	V_{OH}	$V_{CC}=5V, V_{EE}=-6V, I_{OH}=-2mA$	2.5	3.5	5.0	V
	V_{OL}	$V_{CC}=5V, V_{EE}=-6V, I_{OL}=-2mA$	—	—	0.4	V
Linearity error	LE	—	—	$\pm 1/4$	LSB	

Test Circuit

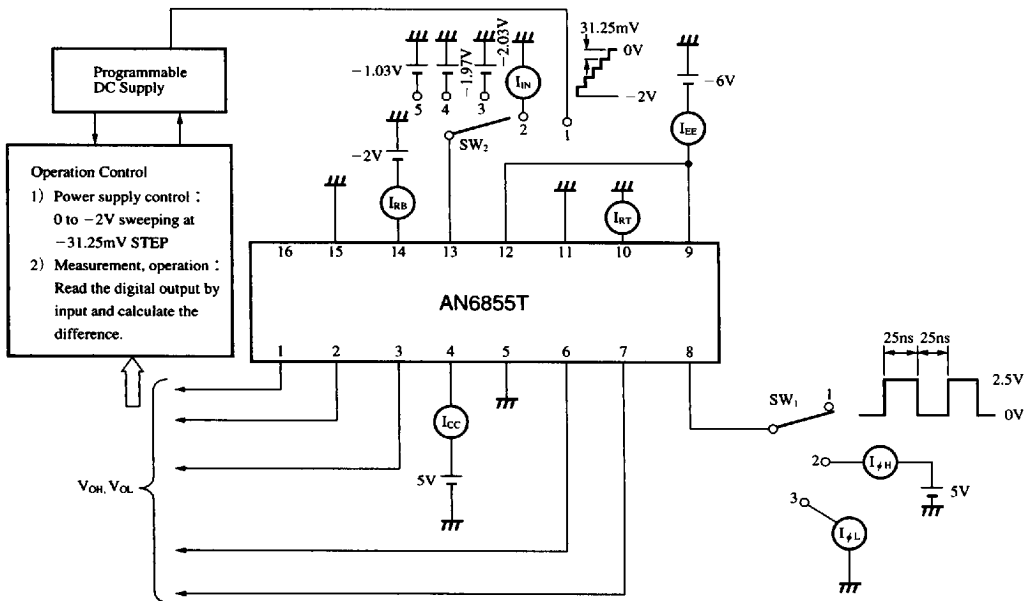

Test Conditions Table

Parameter	Specified item	SW ₁	SW ₂
Supply current	I_{CC}	1	5
	I_{EE}	1	5
Reference resistance current	$I_{Bias(RT)}$	1	5
	$I_{Bias(RB)}$	1	5
Input bias current	I_{Bias}	1	2
Clock input current	$I_{\phi H}$	2	3
	$I_{\phi L}$	3	3
Digital output voltage	V_{OH}	1	4
	$V_{OH(2)}$	1	3
	V_{OL}	1	2
Linearity error	LE	1	1

■ 6932852 0012961 158 ■

Panasonic

■ Sampling Timing Chart

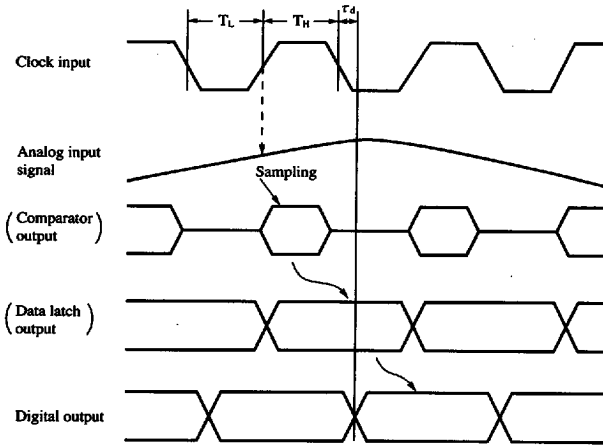

Note) Because the comparator output and data latch output are internal signals, the external pin is not provided.

■ Output Code Table

Comparator No.	Comparator threshold voltage		Digital output										
	Input 2.000VFS 0.125Vstep		INV = "High" or Open (Pin⑤)				INV = "Low" (Pin⑥)						
			Over Flow	M 1	L 2	L 3	L 4	Over Flow	M 1	L 2	L 3	L 4	
01	-0.125		0	0	0	0	0	0	1	1	1	1	1
02	-0.250		0	0	0	0	0	1	1	1	1	1	0
03	-0.375		0	0	0	1	0	0	1	1	1	0	1
04	-0.500		0	0	0	1	1	0	1	1	0	0	0
05	-0.625		0	0	1	0	0	0	1	1	0	1	1
06	-0.750		0	0	1	0	1	0	1	1	0	1	0
07	-0.875		0	0	1	1	0	0	1	1	0	0	1
08	-1.000		0	0	1	1	1	0	1	1	0	0	0
09	-1.125		0	1	0	0	0	0	1	0	1	1	1
10	-1.250		0	1	0	0	1	0	1	0	1	1	0
11	-1.375		0	1	0	1	0	0	1	0	1	0	1
12	-1.500		0	1	0	1	1	0	1	0	1	0	0
13	-1.625		0	1	1	0	0	0	1	0	0	1	1
14	-1.750		0	1	1	0	1	0	1	0	0	1	0
15	-1.875		0	1	1	1	0	0	1	0	0	0	1
16	-2.000		0	1	1	1	1	0	1	0	0	0	0
			1	0	0	0	0	0	0	1	1	1	1

■ 6932852 0012962 094 ■

Panasonic