

AN78MxxNSP Series

3-pin positive output voltage regulator (500 mA type)

■ Overview

The AN78MxxNSP series is a 3-pin fixed positive output type monolithic voltage regulator housed in surface mounting package. Stabilized fixed output voltage is obtained from unstable DC input voltage with using minimum external components. 9 types of fixed output voltage are available; 5 V, 6 V, 7 V, 8 V, 9 V, 10 V, 12 V, 15 V and 18 V. They can be used widely in power circuits with current capacity up to 500 mA.

■ Features

- Output voltage: 5V, 6V, 7V, 8V, 9V, 10V, 12V, 15V, 18V
- Built-in overcurrent limit circuit
- Built-in thermal overload protection circuit
- Built-in ASO (area of safe operation) protection circuit

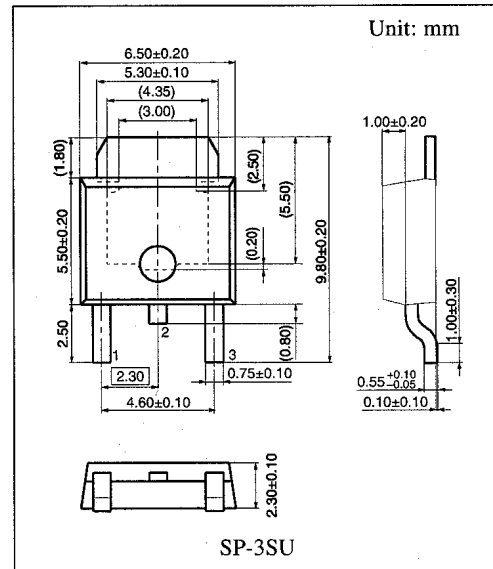

■ Block Diagram

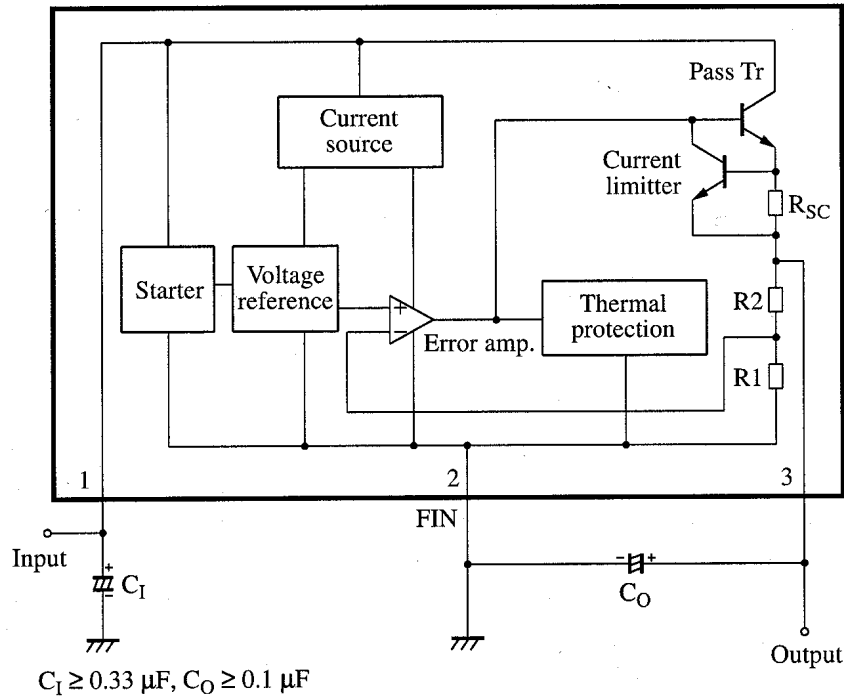

■ Pin Descriptions

Pin No.	Description
1	Input Input voltage pin
2	GND Ground pin (FIN)
3	Output Output voltage pin

■ Absolute Maximum Ratings

Parameter	Symbol	Range	Unit
Supply voltage *2	V_{CC}	35	V
Supply current *3	I_{CC}	—	mA
Power dissipation *4	P_D	—	mW
Operating ambient temperature *1	T_{opr}	-30 to +85	°C
Storage temperature *1	T_{stg}	-55 to +150	°C

Note) 1. *1: Except for the operating ambient temperature and storage temperature, all ratings are for $T_a = 25^\circ\text{C}$.

*2: When V_{CC} of 35 V is applied, the overvoltage protection of ASO protection circuit may shut off the output.

*3: Since this IC has incorporated a current limiter, the current value does not exceed the rating.

*4: When T_j exceeds 150°C (designed value), the internal circuit cuts off the output. Note that the relationship between IC power dissipation and the ambient temperature must follow the derating curve.

2. This IC is not suitable for car electronics equipment.

■ Electrical Characteristics at $T_a = 25^\circ\text{C}$

• AN78M05NSP (5 V type)

The specified condition $T_j = 25^\circ\text{C}$ means that the test should be carried out within so short a test time (within 10 ms) that the characteristic value drift due to the chip junction temperature rise can be ignored.

Unless otherwise specified, $V_1 = 10\text{ V}$, $I_O = 350\text{ mA}$, $C_1 = 0.33\text{ }\mu\text{F}$ and $C_O = 0.1\text{ }\mu\text{F}$

Parameter	Symbol	Conditions	Min	Typ	Max	Unit
Output voltage	V_{O1}	$T_j = 25^\circ\text{C}$	4.8	5	5.2	V
Output voltage tolerance	V_{O2}	$V_1 = 7.5\text{ V to }20\text{ V}$, $I_O = 5\text{ mA to }350\text{ mA}$ $T_j = 25^\circ\text{C}$	4.75	—	5.25	V
Line regulation 1	REG_{IN1}	$V_1 = 7.5\text{ V to }25\text{ V}$, $T_j = 25^\circ\text{C}$	—	3	100	mV
Line regulation 2	REG_{IN2}	$V_1 = 8\text{ V to }25\text{ V}$, $T_j = 25^\circ\text{C}$	—	1	50	mV
Load regulation 1	REG_{L1}	$I_O = 5\text{ mA to }500\text{ mA}$, $T_j = 25^\circ\text{C}$	—	20	100	mV
Load regulation 2	REG_{L2}	$I_O = 5\text{ mA to }200\text{ mA}$, $T_j = 25^\circ\text{C}$	—	10	50	mV
Bias current	I_{Bias}	$T_j = 25^\circ\text{C}$	—	4	6	mA
Bias current fluctuation to input	$\Delta I_{Bias(IN)}$	$V_1 = 8\text{ V to }25\text{ V}$, $T_j = 25^\circ\text{C}$	—	—	0.8	mA
Bias current fluctuation to load	$\Delta I_{Bias(L)}$	$I_O = 5\text{ mA to }350\text{ mA}$, $T_j = 25^\circ\text{C}$	—	—	0.5	mA
Ripple rejection ratio	RR	$V_1 = 8\text{ V to }18\text{ V}$, $I_O = 100\text{ mA}$, $f = 120\text{ Hz}$	62	—	—	dB

• Design reference data

Note) The characteristics listed below are theoretical values based on the IC design and are not guaranteed.

Parameter	Symbol	Conditions	Min	Typ	Max	Unit
Output noise voltage	V_{NO}	$f = 10\text{ Hz to }100\text{ kHz}$	—	40	—	μV
Minimum input/output voltage difference	$V_{DIF(min)}$	$I_O = 500\text{ mA}$, $T_j = 25^\circ\text{C}$	—	2	—	V
Output short-circuit current	$I_{O(Short)}$	$V_1 = 35\text{ V}$, $T_j = 25^\circ\text{C}$	—	300	—	mA
Peak output current	$I_{O(Peak)}$	$T_j = 25^\circ\text{C}$	—	1000	—	mA
Output voltage temperature coefficient	$\Delta V_O / T_a$	$I_O = 5\text{ mA}$, $T_j = 0^\circ\text{C to }125^\circ\text{C}$	—	-0.5	—	$\text{mV}/^\circ\text{C}$
Thermal protection operating temperature	$T_{j(TH)}$	$I_O = 5\text{ mA}$	—	150	—	°C

■ Application Notes

1. $P_D - T_a$ curves of SP-3SU $P_D \approx \frac{3}{4} T_a$

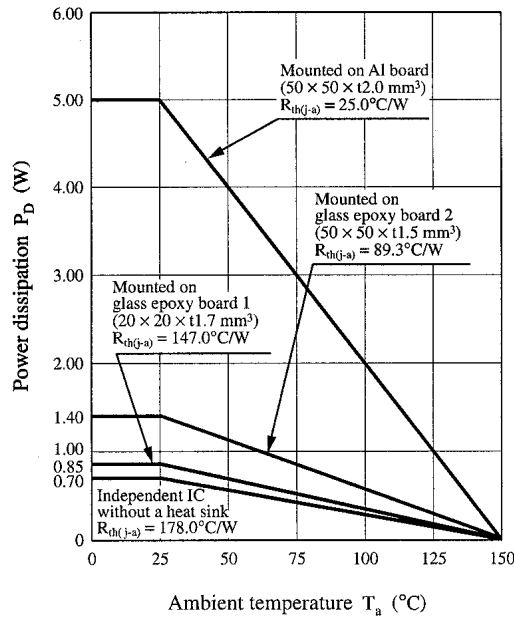

2. Main Characteristics

Output voltage temperature characteristic

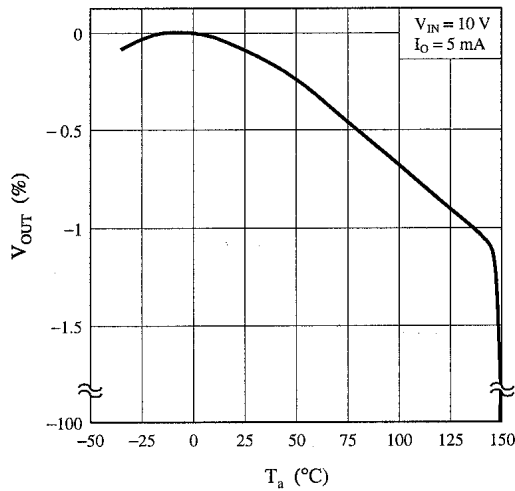

Minimum input/output voltage difference vs. load current characteristic

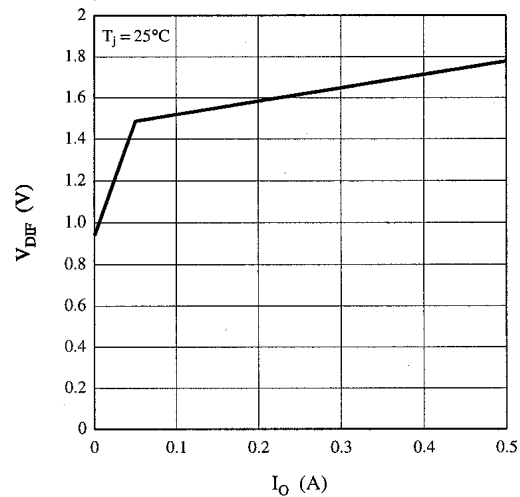

Current limit characteristics

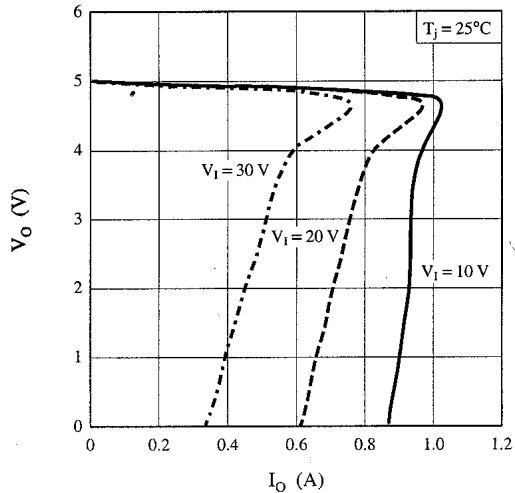

Ripple rejection ratio vs. frequency characteristic

