

# BCR30GM

MEDIUM POWER USE  
INSULATED TYPE, GLASS PASSIVATION TYPE

## BCR30GM

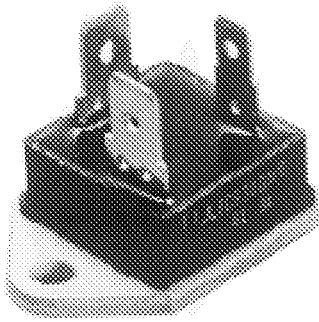

- **It (RMS)** ..... **30A**
- **VDRM** ..... **400V/600V**
- **IFGT I, IRGT I, IRGT II** ..... **50mA**
- **Viso** ..... **2200V**
- **UL Recognized: File No. E80276**

## OUTLINE DRAWING

Dimensions  
in mm

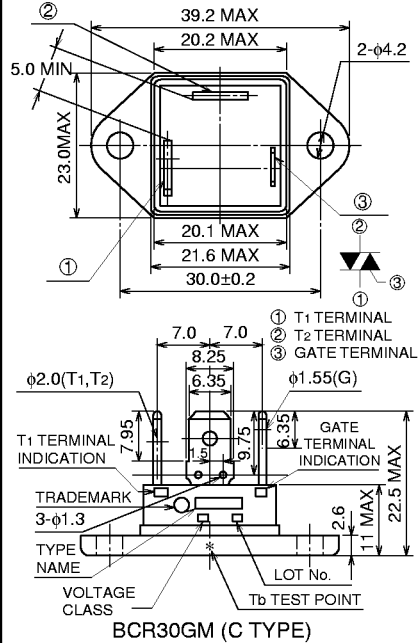

## APPLICATION

Contactless AC switches, light dimmer,  
on/off and speed control of small induction motors, on/off control of copier lamps,  
microwave ovens

## MAXIMUM RATINGS

Symbol	Parameter	Voltage class		Unit
		8	12	
VDRM	Repetitive peak off-state voltage *1	400	600	V
VDSM	Non-repetitive peak off-state voltage *1	500	720	V

Symbol	Parameter	Conditions	Rated	Unit
It (RMS)	RMS on-state current	Commercial frequency, sine full wave 360° conduction, Tb=60°C	30	A
ITSM	Surge on-state current	60Hz sinewave 1 full cycle, peak value, non-repetitive	300	A
Pt	Pt  for fusing	Value corresponding to 1 cycle of half wave 60Hz, surge on-state current	375	A²s
PGM	Peak gate power dissipation		5	W
PG (AV)	Average gate power dissipation		0.5	W
VGM	Peak gate voltage		10	V
IGM	Peak gate current		2	A
Tj	Junction temperature		-40 ~ +125	°C
Tstg	Storage temperature		-40 ~ +125	°C
—	Mounting torque	Screw M4	15	kg·cm
			1.47	N·cm
—	Weight	Typical value	26	g
Viso	Isolation voltage	Ta=25°C, AC 1 minute, T2 · T1 · G terminal to base	2200	V

\*1. Gate open.

# BCR30GM

MEDIUM POWER USE  
INSULATED TYPE, GLASS PASSIVATION TYPE

## ELECTRICAL CHARACTERISTICS

Symbol	Parameter	Test conditions	Limits			Unit
			Min.	Typ.	Max.	
IDRM	Repetitive peak off-state current	T <sub>J</sub> =125°C, V <sub>DRM</sub> applied	—	—	3.0	mA
V <sub>TM</sub>	On-state voltage	T <sub>b</sub> =25°C, I <sub>TM</sub> =45A, Instantaneous measurement	—	—	1.6	V
V <sub>FGT I</sub>	Gate trigger voltage *2	T <sub>J</sub> =25°C, V <sub>D</sub> =6V, R <sub>L</sub> =6Ω, R <sub>G</sub> =330Ω	I	—	2.5	V
V <sub>RGT I</sub>			II	—	2.5	V
V <sub>RGT III</sub>			III	—	2.5	V
I <sub>FGT I</sub>	Gate trigger current *2	T <sub>J</sub> =25°C, V <sub>D</sub> =6V, R <sub>L</sub> =6Ω, R <sub>G</sub> =330Ω	I	—	50	mA
I <sub>RGT I</sub>			II	—	50	mA
I <sub>RGT III</sub>			III	—	50	mA
V <sub>GD</sub>	Gate non-trigger voltage	T <sub>J</sub> =125°C, V <sub>D</sub> =1/2V <sub>DRM</sub>	0.2	—	—	V
R <sub>th (j-b)</sub>	Thermal resistance	Junction to base *4	—	—	1.6	°C/W
(dv/dt) <sub>c</sub>	Critical-rate of rise of off-state commutating voltage		*3	—	—	V/μs

\*2. Measurement using the gate trigger characteristics measurement circuit.

\*3. The critical-rate of rise of the off-state commutating voltage is shown in the table below.

\*4. The contact thermal resistance R<sub>th (b-t)</sub> in case of greasing is 0.5°C/W.

Voltage class	V <sub>DRM</sub> (V)	(dv/dt) <sub>c</sub>			Test conditions	Commutating voltage and current waveforms (inductive load)
		Symbol	Min.	Unit		
8	400	R	—	V/μs	1. Junction temperature T <sub>J</sub> =125°C 2. Rate of decay of on-state commutating current (di/dt) <sub>c</sub> =16A/ms 3. Peak off-state voltage V <sub>D</sub> =400V	
		L	20			
12	600	R	—			
		L	20			

## PERFORMANCE CURVES

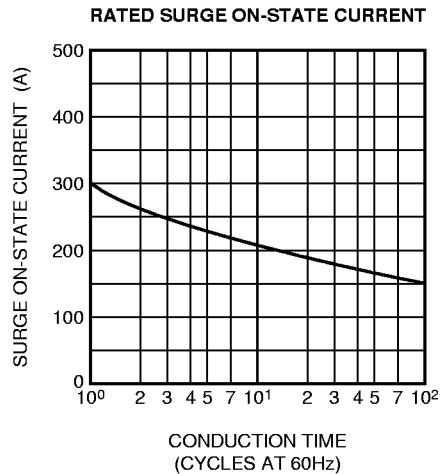
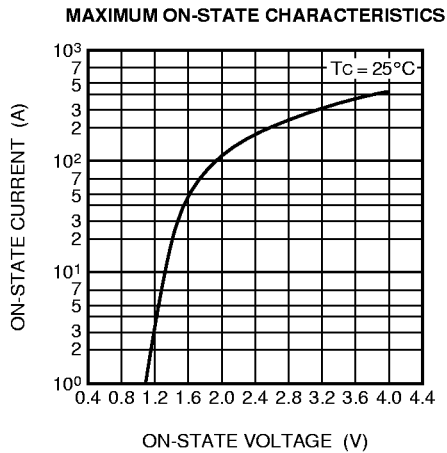

# BCR30GM

MEDIUM POWER USE  
INSULATED TYPE, GLASS PASSIVATION TYPE

**GATE CHARACTERISTICS**

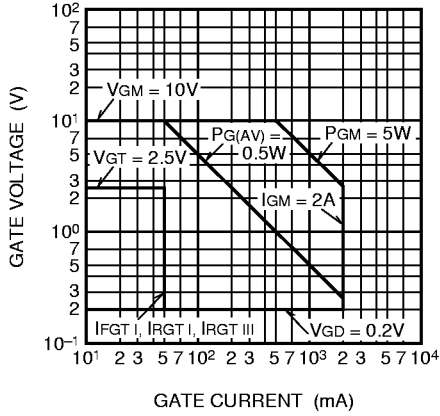

**GATE TRIGGER CURRENT VS. JUNCTION TEMPERATURE**

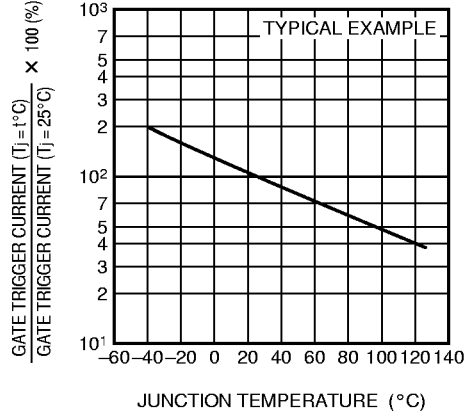

**GATE TRIGGER VOLTAGE VS. JUNCTION TEMPERATURE**

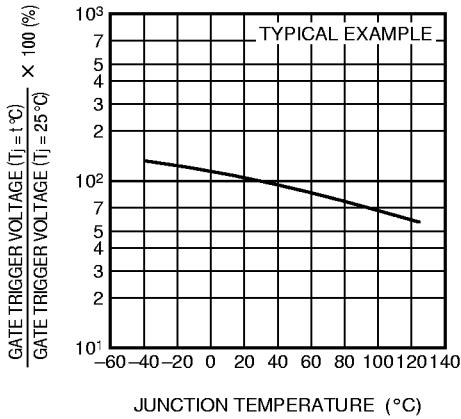

**MAXIMUM TRANSIENT THERMAL IMPEDANCE CHARACTERISTICS (JUNCTION TO CASE)**

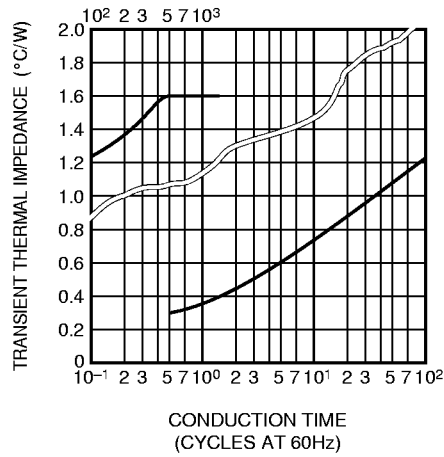

**MAXIMUM ON-STATE POWER DISSIPATION**

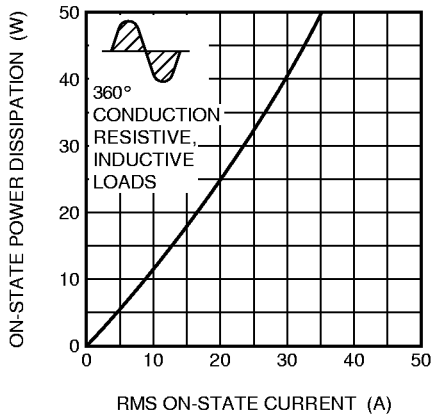

**ALLOWABLE CASE TEMPERATURE VS. RMS ON-STATE CURRENT**

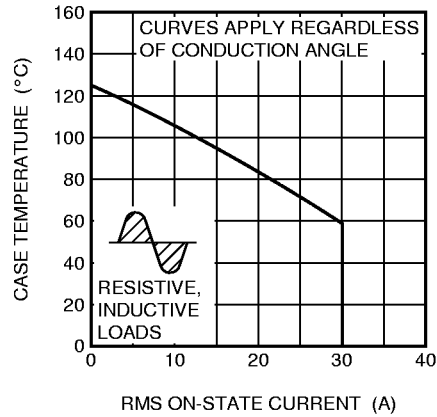

# BCR30GM

MEDIUM POWER USE  
INSULATED TYPE, GLASS PASSIVATION TYPE

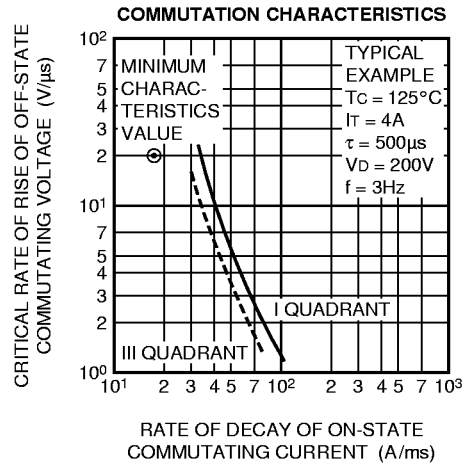
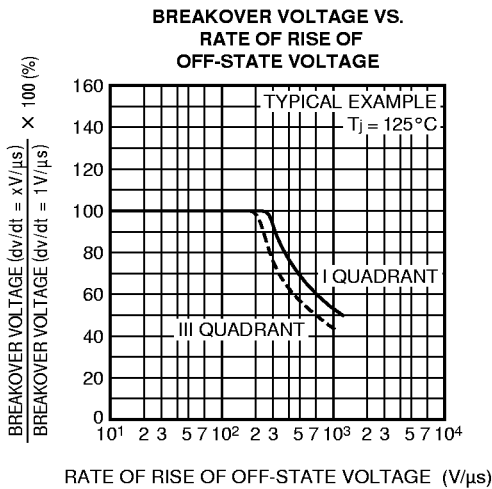
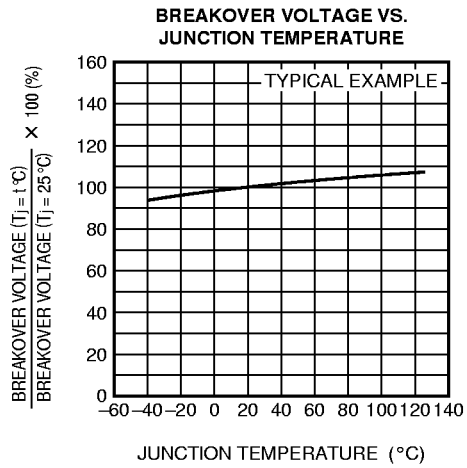
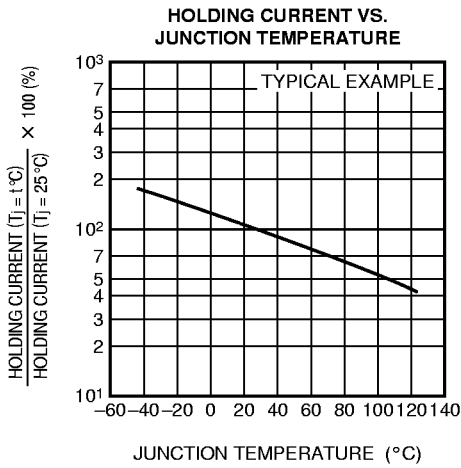
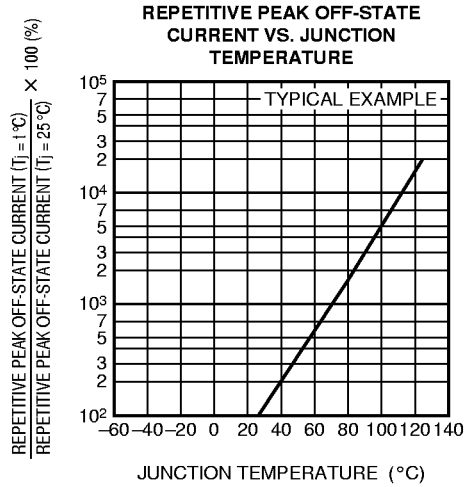
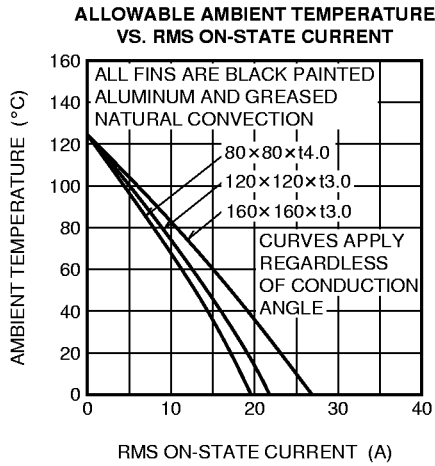

# BCR30GM

MEDIUM POWER USE  
INSULATED TYPE, GLASS PASSIVATION TYPE

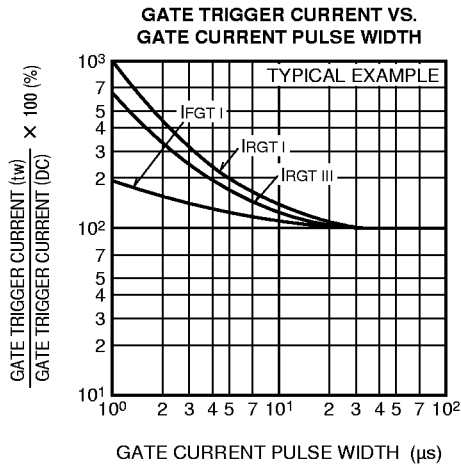

**GATE TRIGGER CHARACTERISTICS TEST CIRCUITS**

