

**Silicon Diffused Power Transistor**

**BU4522AX**

**GENERAL DESCRIPTION**

New generation, high-voltage, high-speed switching npn transistor in a plastic full-pack envelope intended for use in horizontal deflection circuits of colour TV receivers and PC monitors.

**QUICK REFERENCE DATA**

SYMBOL	PARAMETER	CONDITIONS	TYP.	MAX.	UNIT
$V_{CESM}$	Collector-emitter voltage peak value	$V_{BE} = 0\text{ V}$	-	1500	V
$V_{CEO}$	Collector-emitter voltage (open base)		-	800	V
$I_C$	Collector current (DC)		-	10	A
$I_{CM}$	Collector current peak value		-	25	A
$P_{tot}$	Total power dissipation	$T_{hs} \leq 25\text{ }^\circ\text{C}$	-	45	W
$V_{CESat}$	Collector-emitter saturation voltage	$I_C = 7\text{ A}; I_B = 1.75\text{ A}$	-	3.0	V
$I_{Csat}$	Collector saturation current (Fig 17)	$f = 16\text{ kHz}$	7	-	A
		$f = 64\text{ kHz}$	6	-	A
$t_f$	Fall time	$I_{Csat} = 7\text{ A}; f = 16\text{ kHz}$	285	400	ns
		$I_{Csat} = 6\text{ A}; f = 64\text{ kHz}$	170	230	ns

**PINNING - SOT399**

PIN	DESCRIPTION
1	base
2	collector
3	emitter
case	isolated

**PIN CONFIGURATION**

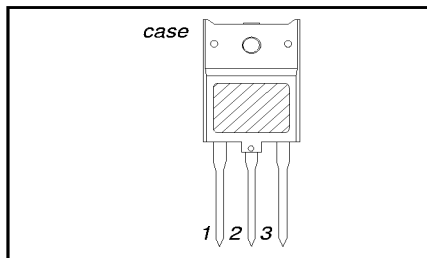

**SYMBOL**

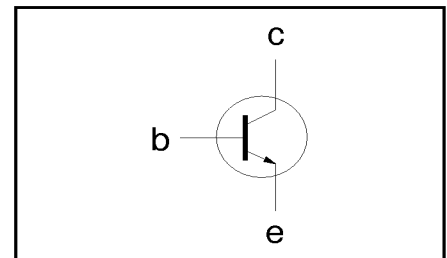

**LIMITING VALUES**

Limiting values in accordance with the Absolute Maximum Rating System (IEC 134)

SYMBOL	PARAMETER	CONDITIONS	MIN.	MAX.	UNIT
$V_{CESM}$	Collector-emitter voltage peak value	$V_{BE} = 0\text{ V}$	-	1500	V
$V_{CEO}$	Collector-emitter voltage (open base)		-	800	V
$I_C$	Collector current (DC)		-	10	A
$I_{CM}$	Collector current peak value		-	25	A
$I_B$	Base current (DC)		-	6	A
$I_{BM}$	Base current peak value		-	9	A
$-I_{BM}$	Reverse base current peak value <sup>1</sup>		-	6	A
$P_{tot}$	Total power dissipation	$T_{hs} \leq 25\text{ }^\circ\text{C}$	-	45	W
$T_{stg}$	Storage temperature		-55	150	$^\circ\text{C}$
$T_j$	Junction temperature		-	150	$^\circ\text{C}$

**THERMAL RESISTANCES**

SYMBOL	PARAMETER	CONDITIONS	TYP.	MAX.	UNIT
$R_{th\ j-hs}$	Junction to heatsink	with heatsink compound	-	2.8	K/W
$R_{th\ j-a}$	Junction to ambient	in free air	35	-	K/W

<sup>1</sup> Turn-off current.

## Silicon Diffused Power Transistor

BU4522AX

**ISOLATION LIMITING VALUE & CHARACTERISTIC** $T_{hs} = 25\text{ }^{\circ}\text{C}$  unless otherwise specified

SYMBOL	PARAMETER	CONDITIONS	MIN.	TYP.	MAX.	UNIT
$V_{isol}$	Repetitive peak voltage from all three terminals to external heatsink	R.H. $\leq 65\%$ ; clean and dustfree	-	-	2500	V
$C_{isol}$	Capacitance from T2 to external heatsink	$f = 1\text{ MHz}$	-	22	-	pF

**STATIC CHARACTERISTICS** $T_{hs} = 25\text{ }^{\circ}\text{C}$  unless otherwise specified

SYMBOL	PARAMETER	CONDITIONS	MIN.	TYP.	MAX.	UNIT
$I_{CES}$	Collector cut-off current <sup>2</sup>	$V_{BE} = 0\text{ V}; V_{CE} = V_{CESMmax}$	-	-	1.0	mA
$I_{CES}$		$V_{BE} = 0\text{ V}; V_{CE} = V_{CESMmax}$ $T_j = 125\text{ }^{\circ}\text{C}$	-	-	2.0	mA
$I_{EBO}$	Emitter cut-off current	$V_{EB} = 7.5\text{ V}; I_C = 0\text{ A}$	-	-	1.0	mA
$V_{BEBO}$	Emitter-base breakdown voltage	$I_B = 1\text{ mA}$	7.5	13.5	-	V
$V_{CEOsust}$	Collector-emitter sustaining voltage	$I_B = 0\text{ A}; I_C = 100\text{ mA};$ $L = 25\text{ mH}$	800	-	-	V
$V_{CEsat}$	Collector-emitter saturation voltage	$I_C = 7\text{ A}; I_B = 1.75\text{ A}$	-	-	3.0	V
$V_{BEsat}$	Base-emitter saturation voltage	$I_C = 7\text{ A}; I_B = 1.75\text{ A}$	0.85	0.94	1.03	V
$h_{FE}$	DC current gain	$I_C = 1\text{ A}; V_{CE} = 5\text{ V}$	-	10	-	
$h_{FE}$		$I_C = 7\text{ A}; V_{CE} = 5\text{ V}$	4.2	5.8	7.3	

**DYNAMIC CHARACTERISTICS** $T_{hs} = 25\text{ }^{\circ}\text{C}$  unless otherwise specified

SYMBOL	PARAMETER	CONDITIONS	TYP.	MAX.	UNIT
$t_s$	Switching times (16 kHz line deflection circuit)	$f = 16\text{ kHz}; I_{Csat} = 7\text{ A}; I_{B1} = 1.4\text{ A};$ $(I_{B2} = -3.5\text{ A})$			
$t_f$	Turn-off storage time		3.5	4.3	$\mu\text{s}$
$t_f$	Turn-off fall time		285	400	ns
$t_s$	Switching times (64 kHz line deflection circuit)	$f = 64\text{ kHz}; I_{Csat} = 6\text{ A}; I_{B1} = 1.2\text{ A};$ $(I_{B2} = -3.6\text{ A})$			
$t_f$	Turn-off storage time		2.3	2.7	$\mu\text{s}$
$t_f$	Turn-off fall time		170	230	ns

<sup>2</sup> Measured with half sine-wave voltage (curve tracer).

Silicon Diffused Power Transistor

BU4522AX

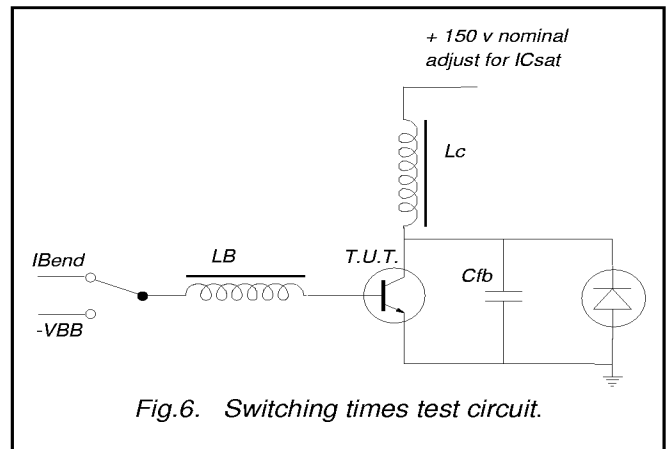
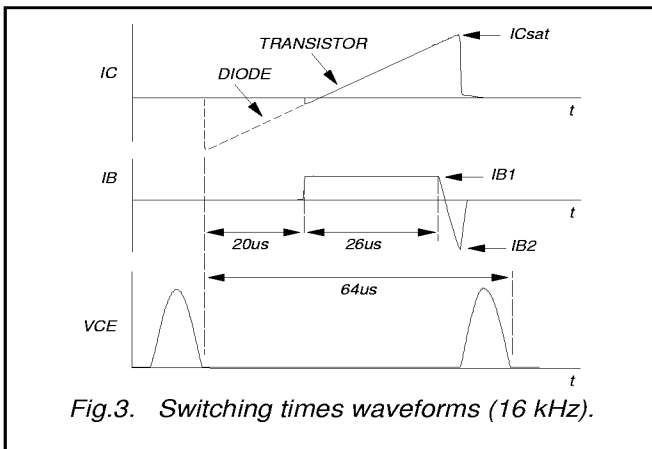
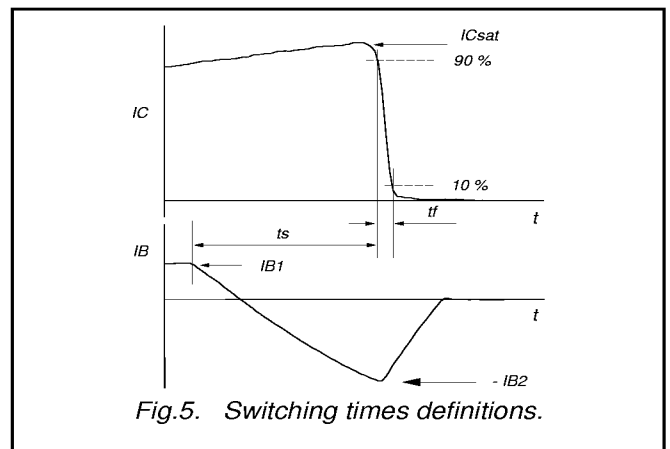
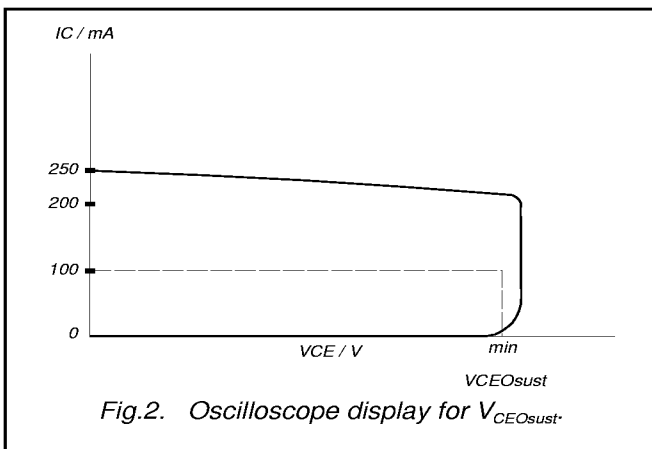
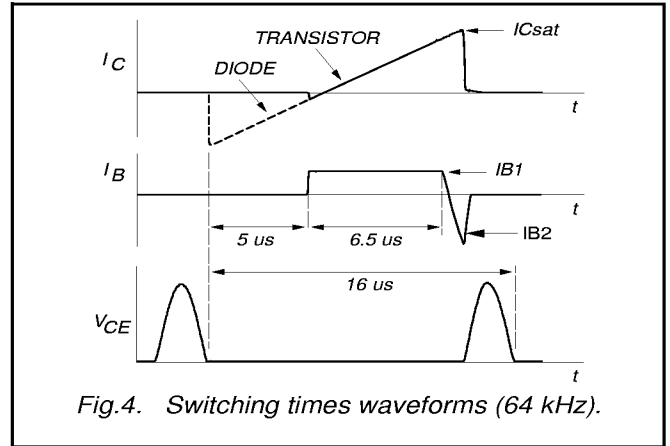
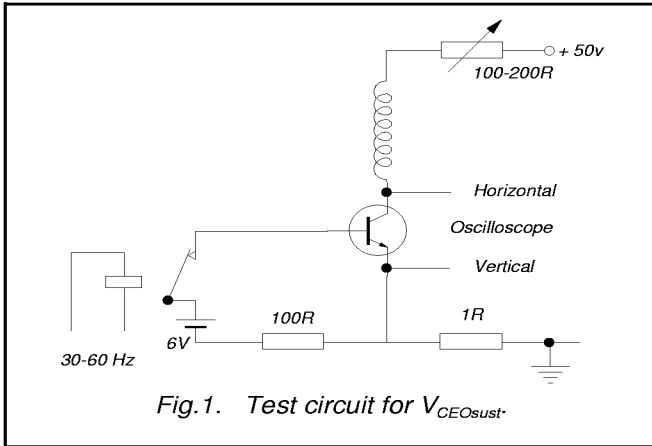

Silicon Diffused Power Transistor

BU4522AX

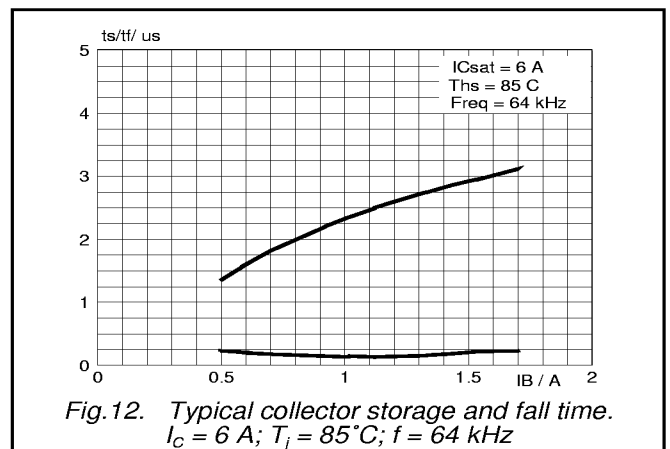
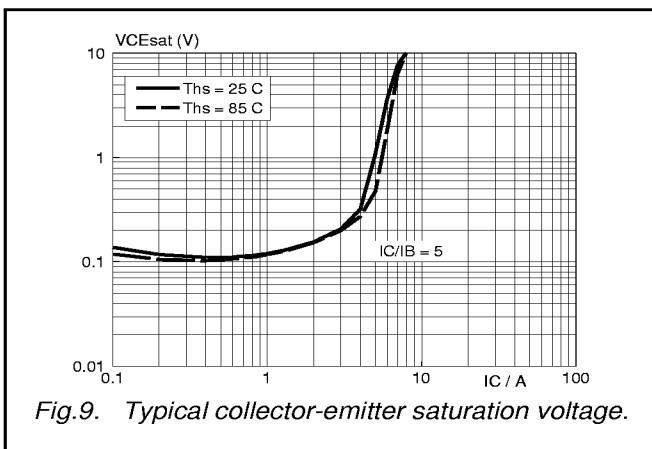
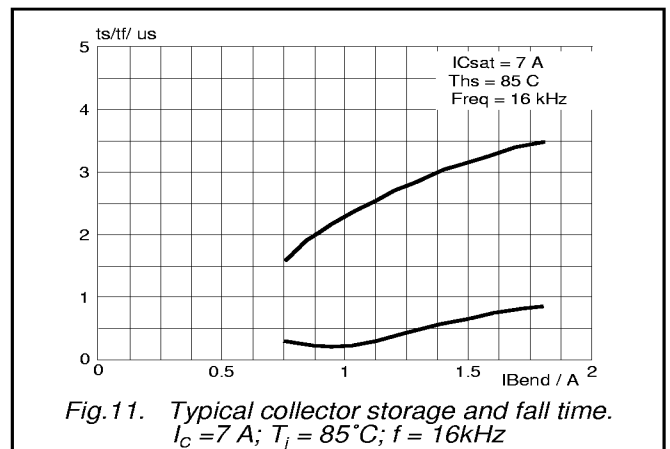
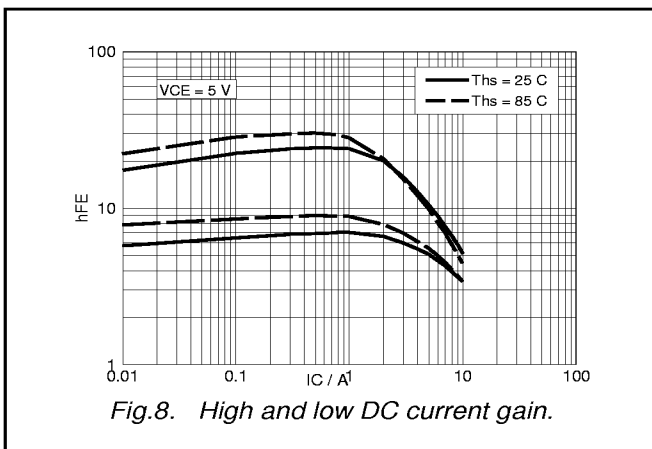
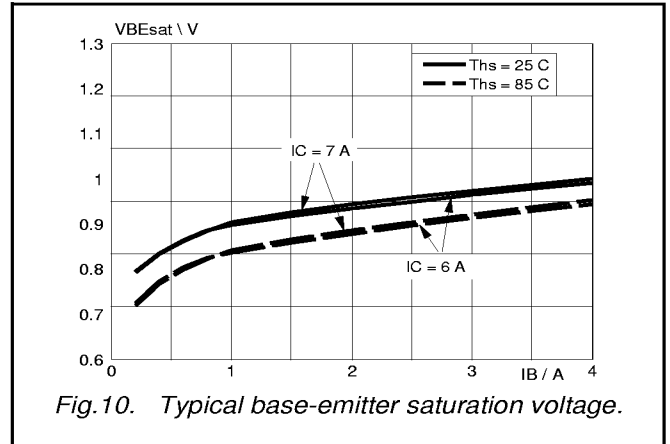
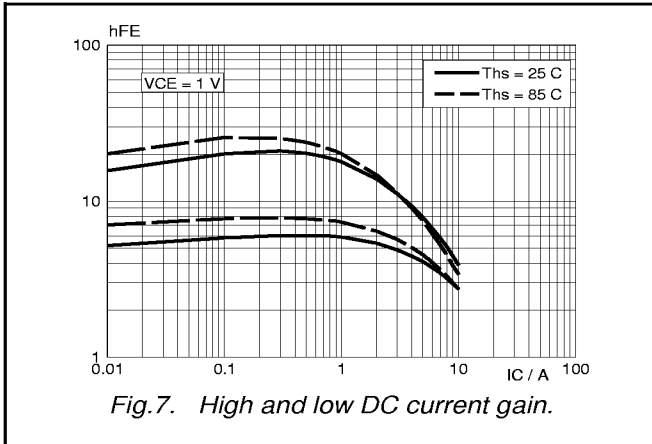

Silicon Diffused Power Transistor

BU4522AX

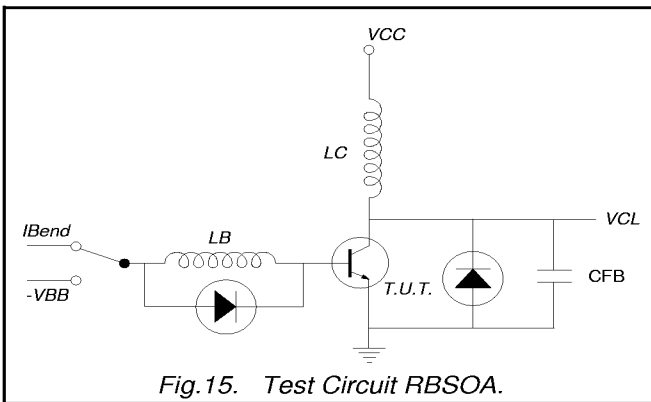
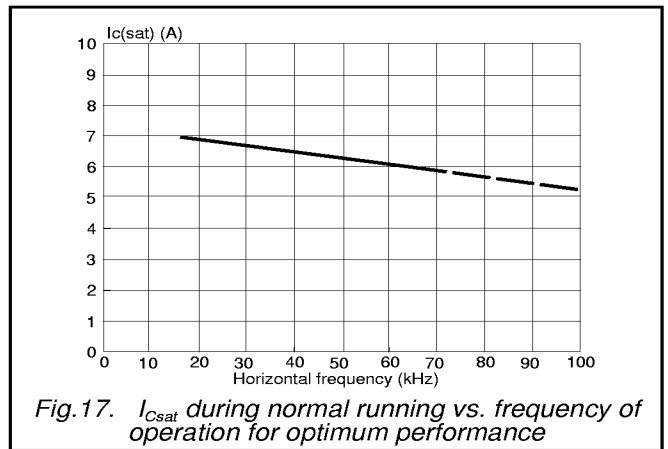
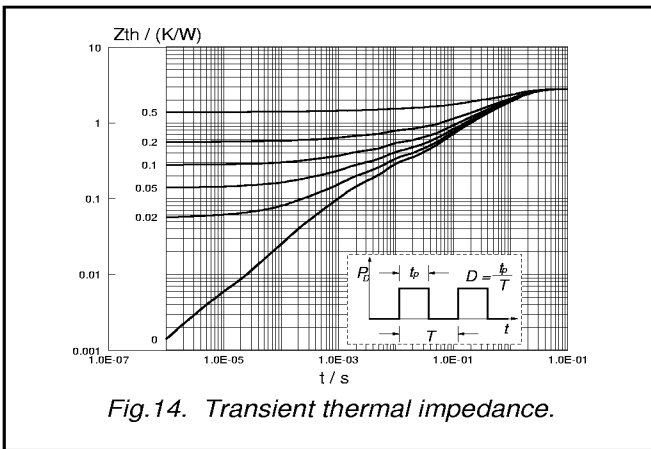
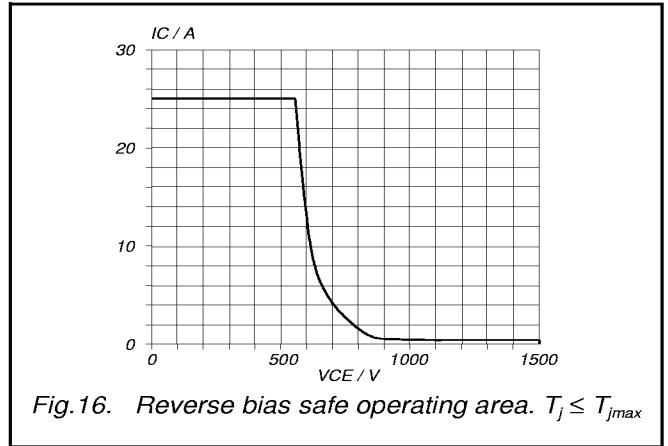
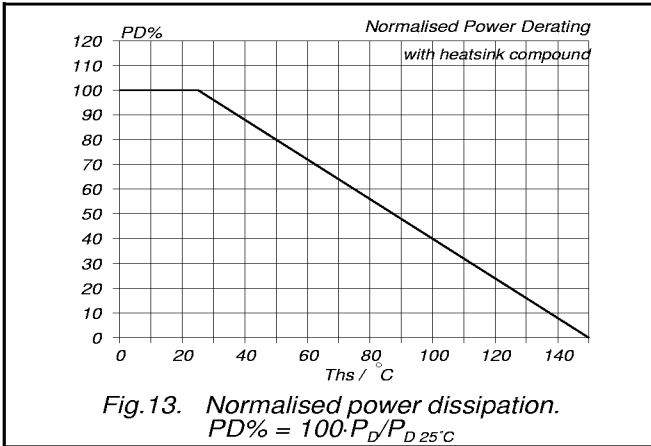

Silicon Diffused Power Transistor

BU4522AX

**MECHANICAL DATA**

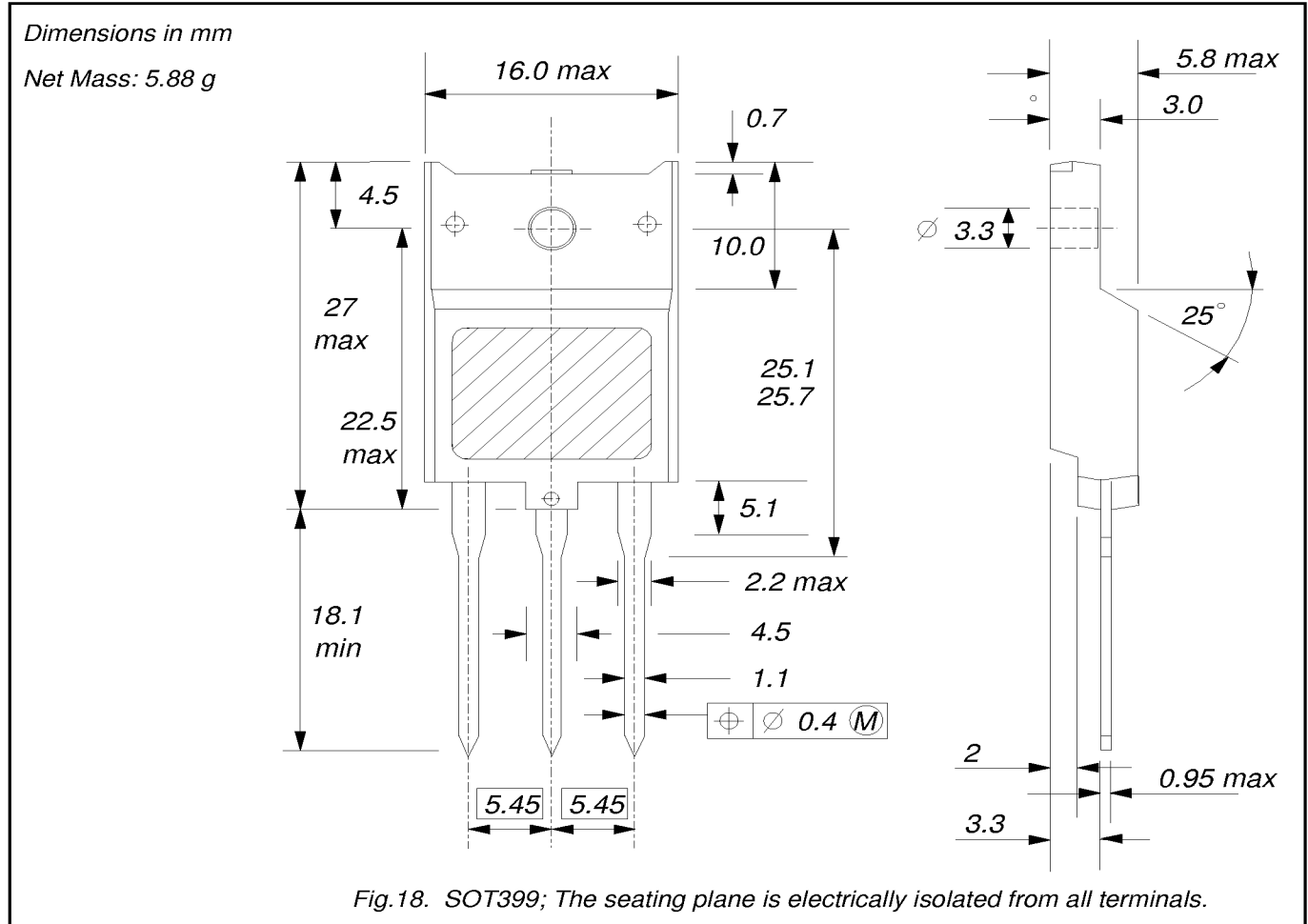

**Notes**

1. Refer to mounting instructions for F-pack envelopes.
2. Epoxy meets UL94 V0 at 1/8".