

HIGH VOLTAGE FAST-SWITCHING NPN POWER TRANSISTOR

- SGS-THOMSON PREFERRED SALESTYPES
- HIGH VOLTAGE CAPABILITY
- LOW SPREAD OF DYNAMIC PARAMETERS
- MINIMUM LOT-TO-LOT SPREAD FOR RELIABLE OPERATION
- VERY HIGH SWITCHING SPEED
- FULLY CHARACTERISED AT 125°C
- LARGE RBSOA
- U.L. RECOGNISED ISOWATT220 PACKAGE (U.L. FILE # E81734 (N)): ISOLATION VOLTAGE 1500V_{RMS}

APPLICATIONS

- ELECTRONIC BALLASTS FOR FLUORESCENT LIGHTING
- SWITCH MODE POWER SUPPLIES

DESCRIPTION

The BUL57 and BUL57PI are manufactured using high voltage Multi Epitaxial Planar technology for high switching speeds and high voltage capability. They use a Cellular Emitter structure to enhance switching speeds. The BUL series is designed for use in lighting applications and low cost switch-mode power supplies.

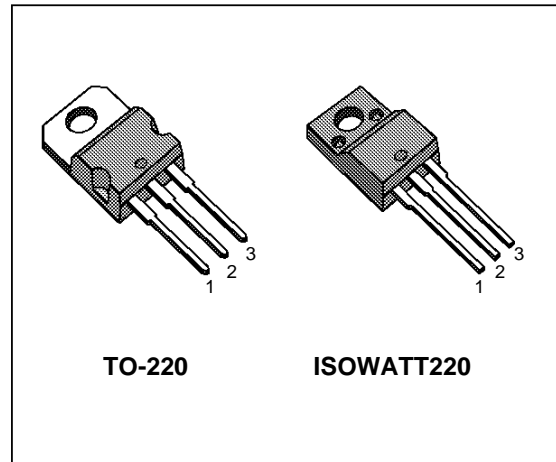

INTERNAL SCHEMATIC DIAGRAM

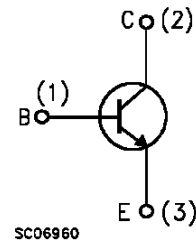

ABSOLUTE MAXIMUM RATINGS

Symbol	Parameter	Value		Unit
		BUL57	BUL57PI	
V _{CES}	Collector-Emitter Voltage (V _{BE} = 0)	700		V
V _{CEO}	Collector-Emitter Voltage (I _B = 0)	400		V
V _{EBO}	Emitter-Base Voltage (I _C = 0)	9		V
I _C	Collector Current	7		A
I _{CM}	Collector Peak Current (t _p < 5 ms)	11		A
I _B	Base Current	4		A
I _{BM}	Base Peak Current (t _p < 5 ms)	7		A
P _{tot}	Total Dissipation at T _c = 25 °C	75	35	W
T _{stg}	Storage Temperature Range	-65 to 150		°C
T _j	Max. Operating Junction Temperature	150		°C

THERMAL DATA

			TO-220	ISOWATT220	
R _{thj-case}	Thermal Resistance Junction-Case	Max	1.65	3.58	°C/W
R _{thj-amb}	Thermal Resistance Junction-Ambient	Max	62.5	62.5	°C/W

ELECTRICAL CHARACTERISTICS (T_{case} = 25 °C unless otherwise specified)

Symbol	Parameter	Test Conditions	Min.	Typ.	Max.	Unit
I _{CES}	Collector Cut-off Current (V _{BE} = 0)	V _{CE} = 700 V V _{CE} = 700 V T _j = 125 °C			100 500	μA μA
I _{CEO}	Collector Cut-off Current (I _B = 0)	V _{EC} = 400 V			250	μA
V _{CEO(sus)}	Collector-Emitter Sustaining Voltage	I _C = 100 mA L = 25 mH	400			V
V _{EBO}	Emitter-Base Voltage (I _C = 0)	I _E = 10 mA	9			V
V _{CE(sat)*}	Collector-Emitter Saturation Voltage	I _C = 2 A I _B = 0.4 A I _C = 3 A I _B = 0.6 A I _C = 4 A I _B = 0.8 A I _C = 5 A I _B = 1 A			0.65 0.75 1.2 2	V V V V
V _{BE(sat)*}	Base-Emitter Saturation Voltage	I _C = 2 A I _B = 0.4 A I _C = 5 A I _B = 1 A			1.2 1.6	V V
h _{FE*}	DC Current Gain	I _C = 2 A V _{CE} = 5 V I _C = 4 A V _{CE} = 5 V I _C = 10 mA V _{CE} = 5 V	15 6 8		40	
t _s t _f	INDUCTIVE LOAD Storage Time Fall Time	I _C = 3 A V _{CL} = 250 V I _{B1} = 0.6 A I _{B2} = -1.2 A L = 200 μH		1.8 60	2.6 110	μs ns
t _s t _f	INDUCTIVE LOAD Storage Time Fall Time	I _C = 3 A V _{CL} = 250 V I _{B1} = 0.6 A I _{B2} = -1.2 A L = 200 μH T _j = 125 °C		2.6 110		μs ns
t _s t _f	INDUCTIVE LOAD Storage Time Fall Time	I _C = 3 A I _{B1} = 0.6 A V _{BE(off)} = -5 V R _{BB} = 0 Ω V _{CL} = 250 V L = 200 μH		1 54	1.6 100	μs ns
t _s t _f	INDUCTIVE LOAD Storage Time Fall Time	I _C = 3 A I _{B1} = 0.6 A V _{BE(off)} = -5V R _{BB} = 0 Ω V _{CL} = 250 V L = 200 μH T _j = 125 °C		1.5 90		μs ns

* Pulsed: Pulse duration = 300 μs, duty cycle 1.5 %

Safe Operating Areas

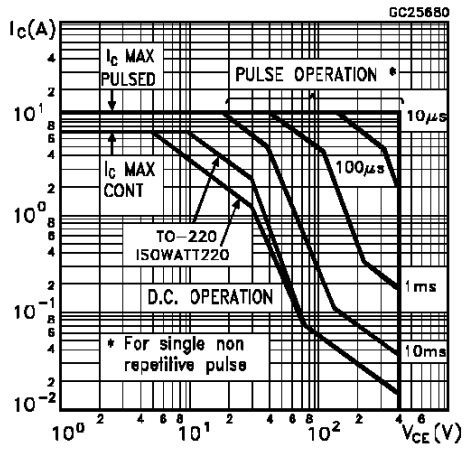

Derating Curves

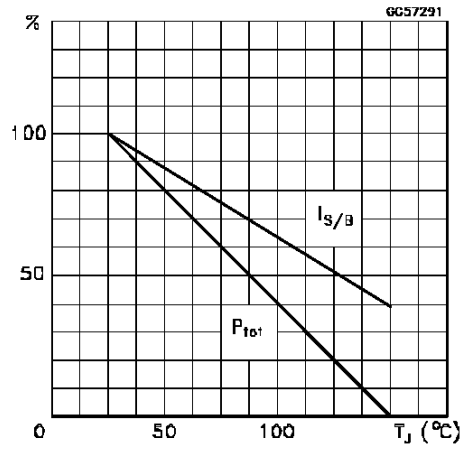

DC Current Gain

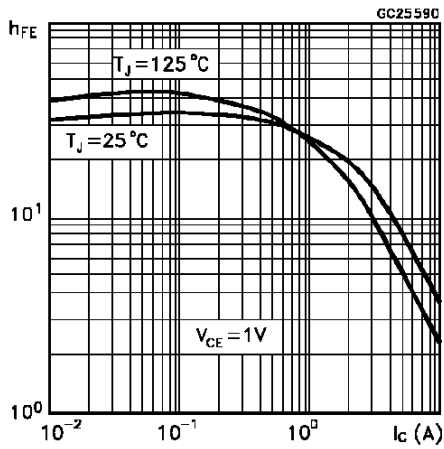

DC Current Gain

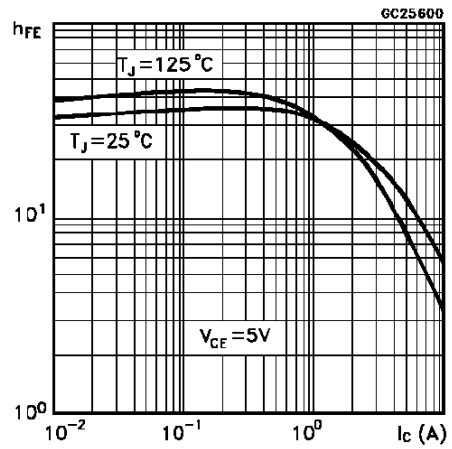

Collector Emitter Saturation Voltage

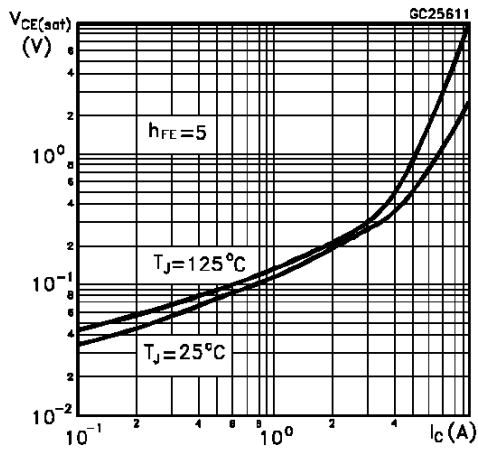

Base Emitter Saturation Voltage

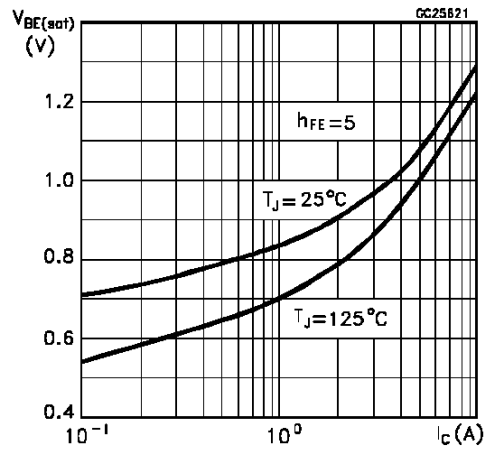

Inductive Fall Time

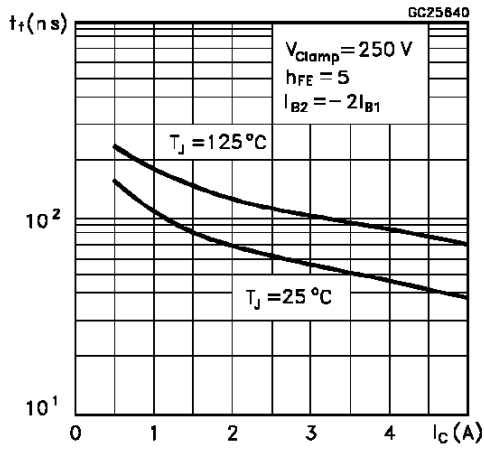

Inductive Storage Time

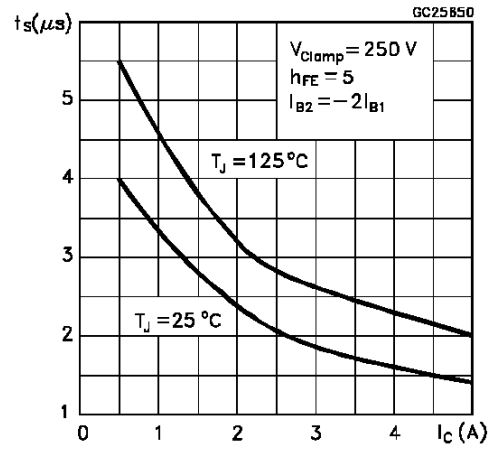

Inductive Fall Time

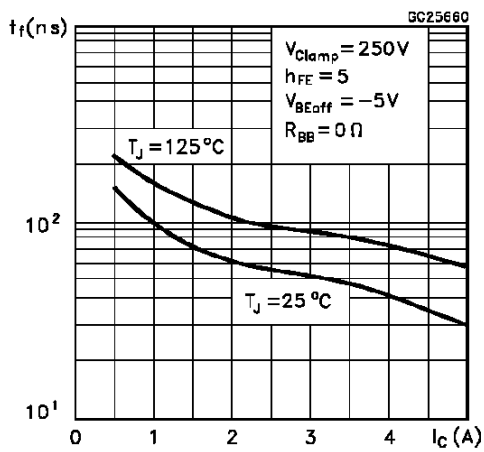

Inductive Storage Time

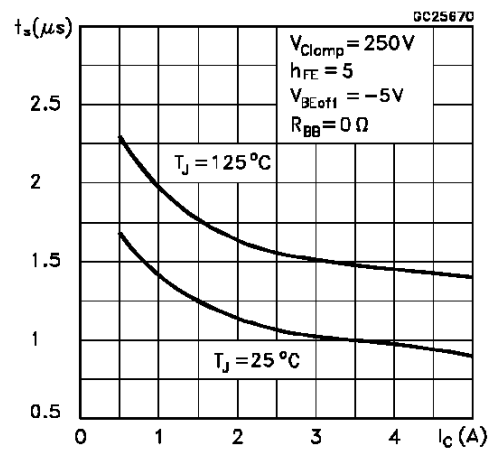

Reverse Biased SOA

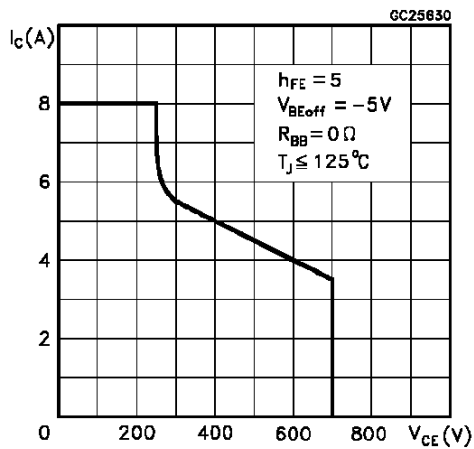

RBSOA and Inductive Load Switching Test Circuit

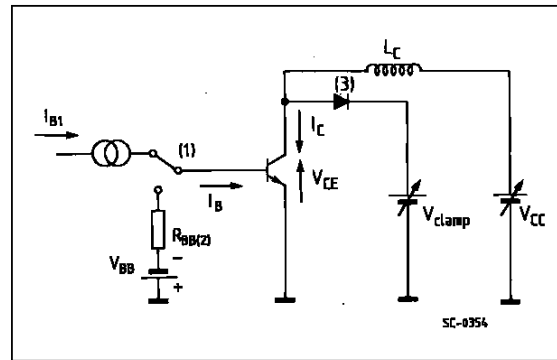

- (1) Fast electronic switch
- (2) Non-inductive Resistor
- (3) Fast recovery rectifier

TO-220 MECHANICAL DATA

DIM.	mm			inch		
	MIN.	TYP.	MAX.	MIN.	TYP.	MAX.
A	4.40		4.60	0.173		0.181
C	1.23		1.32	0.048		0.051
D	2.40		2.72	0.094		0.107
D1		1.27			0.050	
E	0.49		0.70	0.019		0.027
F	0.61		0.88	0.024		0.034
F1	1.14		1.70	0.044		0.067
F2	1.14		1.70	0.044		0.067
G	4.95		5.15	0.194		0.203
G1	2.4		2.7	0.094		0.106
H2	10.0		10.40	0.393		0.409
L2		16.4			0.645	
L4	13.0		14.0	0.511		0.551
L5	2.65		2.95	0.104		0.116
L6	15.25		15.75	0.600		0.620
L7	6.2		6.6	0.244		0.260
L9	3.5		3.93	0.137		0.154
DIA.	3.75		3.85	0.147		0.151

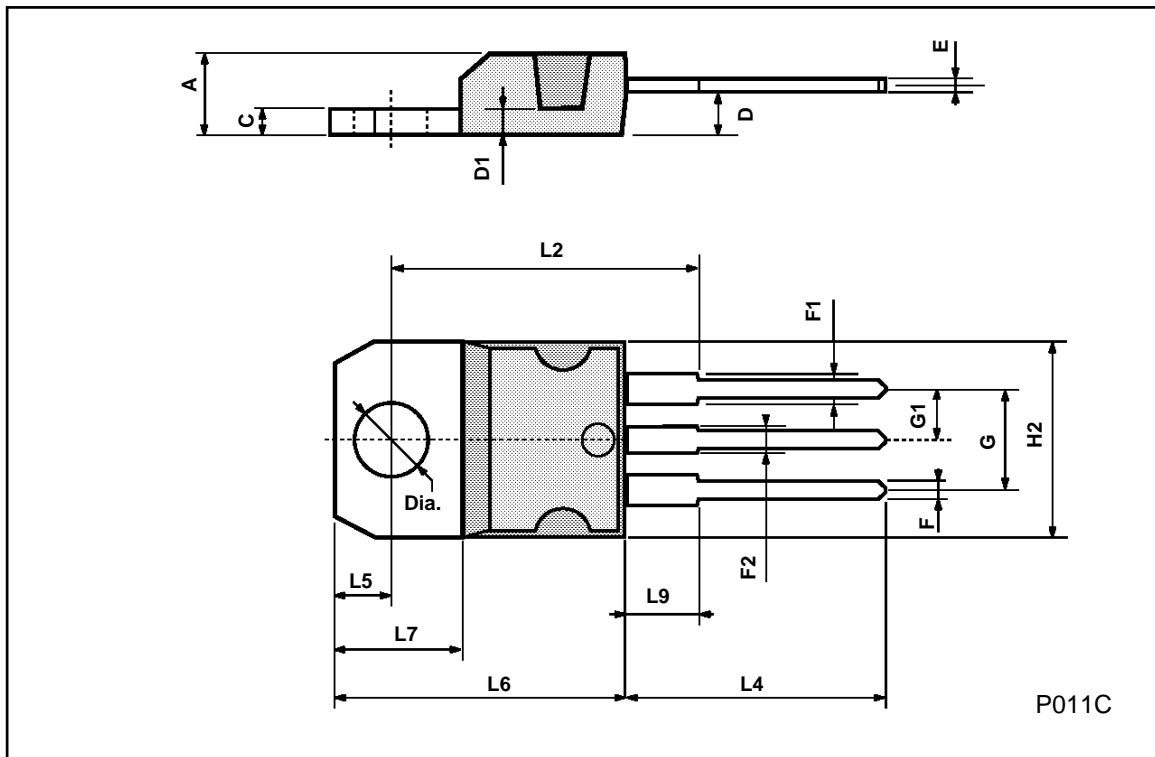

P011C

ISOWATT220 MECHANICAL DATA

DIM.	mm			inch		
	MIN.	TYP.	MAX.	MIN.	TYP.	MAX.
A	4.4		4.6	0.173		0.181
B	2.5		2.7	0.098		0.106
D	2.5		2.75	0.098		0.108
E	0.4		0.7	0.015		0.027
F	0.75		1	0.030		0.039
F1	1.15		1.7	0.045		0.067
F2	1.15		1.7	0.045		0.067
G	4.95		5.2	0.195		0.204
G1	2.4		2.7	0.094		0.106
H	10		10.4	0.393		0.409
L2		16			0.630	
L3	28.6		30.6	1.126		1.204
L4	9.8		10.6	0.385		0.417
L6	15.9		16.4	0.626		0.645
L7	9		9.3	0.354		0.366
Ø	3		3.2	0.118		0.126

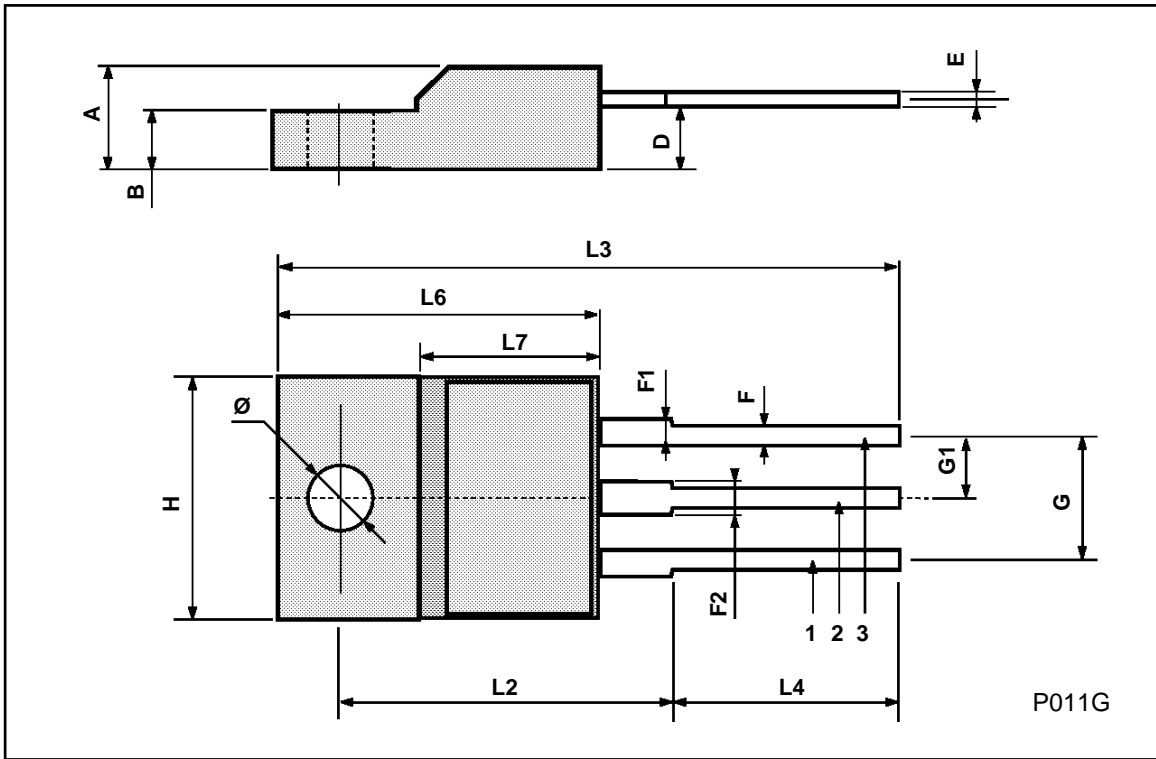

Information furnished is believed to be accurate and reliable. However, SGS-THOMSON Microelectronics assumes no responsibility for the consequences of use of such information nor for any infringement of patents or other rights of third parties which may result from its use. No license is granted by implication or otherwise under any patent or patent rights of SGS-THOMSON Microelectronics. Specifications mentioned in this publication are subject to change without notice. This publication supersedes and replaces all information previously supplied. SGS-THOMSON Microelectronics products are not authorized for use as critical components in life support devices or systems without express written approval of SGS-THOMSON Microelectronics.

© 1994 SGS-THOMSON Microelectronics - All Rights Reserved

SGS-THOMSON Microelectronics GROUP OF COMPANIES
Australia - Brazil - France - Germany - Hong Kong - Italy - Japan - Korea - Malaysia - Malta - Morocco - The Netherlands -
Singapore - Spain - Sweden - Switzerland - Taiwan - Thailand - United Kingdom - U.S.A