

SURFACE MOUNT

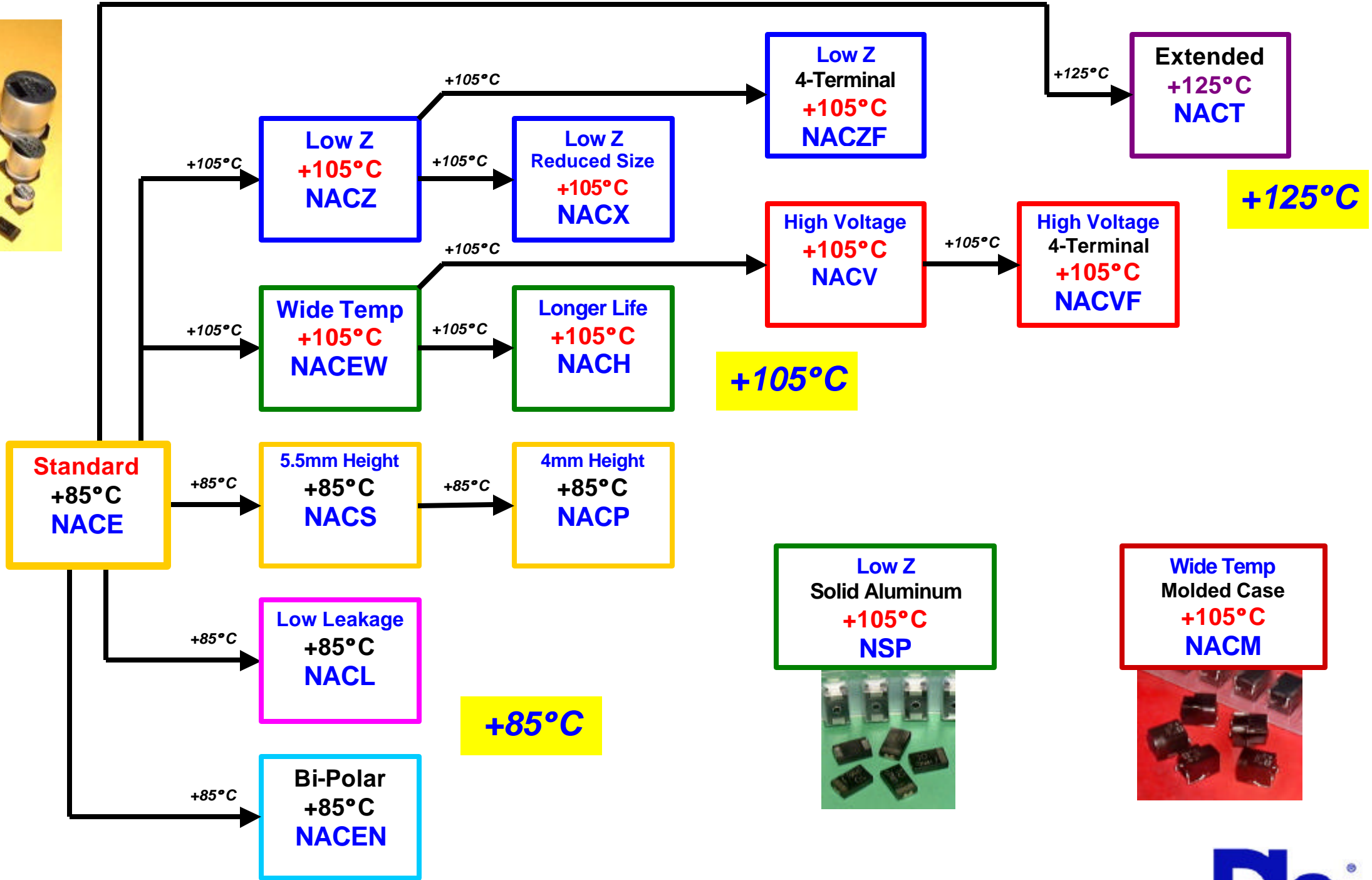

Surface Mount Aluminum Electrolytic Capacitors

CASE DIMENSIONS (mm)*

Case Size	D \varnothing \pm 0.5	L max.	A \pm 0.2	B \pm 0.3	I \pm 0.30	W	P \pm 0.3	R	T
3x5.5	3.0	5.5	3.3	3.3	1.5	0.45 - 0.75	0.6	-	-
4x5.5	4.0	5.5	4.3	4.3	1.8	0.5 - 0.8	1.0	-	-
5x5.5	5.0	5.5	5.3	5.3	2.1	0.5 - 0.8	1.4	-	-
6.3x5.5	6.3	5.5	6.6	6.6	2.5	0.5 - 0.8	2.2	-	-
6.3x6.3	6.3	6.3	6.6	6.6	2.5	0.5 - 0.8	2.2	-	-
6.3x8	6.3	8.0	6.6	6.6	2.5	0.5 - 0.8	2.2	-	-
8x10.5	8.0	10.5	8.3	8.3	2.9	0.7 - 1.0	3.2	-	-
10x10.5	10.0	10.5	10.3	10.3	3.2	0.7 - 1.0	4.6	-	-
10x14	10.0	14.5	10.3	10.3	3.5	0.7 - 1.1	4.6	-	-
10x18	10.0	18.5	10.3	10.3	3.5	0.7 - 1.1	4.6	-	-
10x22	10.0	22.5	10.3	10.3	3.5	0.7 - 1.1	4.6	-	-
12.5x14	12.5	14.0	12.8	12.8	4.5	0.7 - 1.0	4.6	-	-
12.5x17	12.5	17.5	13.5	13.5	4.7	0.6 - 1.2	4.4	-	-
12.5x22	12.5	22.5	13.5	13.5	4.7	0.6 - 1.2	4.4	-	-
16x17	16.0	17.5	17.0	17.0	5.5	0.9 - 1.5	6.7	5.0	2.5
16x22	16.0	22.5	17.0	17.0	5.5	0.9 - 1.5	6.7	5.0	2.5
18x17	18.0	17.5	19.0	19.0	6.5	0.9 - 1.5	6.7	5.0	3.5
18x22	18.0	22.5	19.0	19.0	6.5	0.9 - 1.5	6.7	5.0	3.5

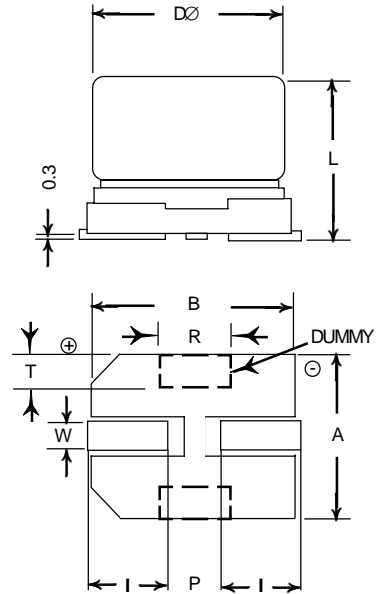

TAPING SPECIFICATIONS (mm)

*See page 152 for dimensions on parts with 4.0 and 4.6mm height.

1. Leader and ending tape: Minimum 10 empty pockets and 20 cm of cover tape.
2. Connection: within 3 connection per reel.

CARRIER TAPE

Case Size	A \pm 0.5	B \pm 0.5	C \pm 0.3	D \pm 0.1	P \pm 0.1	T \pm 0.2
3x5.5	3.7	3.7	12.0	5.5	8.0	5.8
4x4	4.7	4.7	12.0	5.5	8.0	4.5
4x4.6	4.7	4.7	12.0	5.5	8.0	5.1
4x5.5	4.7	4.7	12.0	5.5	8.0	5.8
4x6.3	4.7	4.7	12.0	5.5	8.0	6.6
5x4	5.7	5.7	12.0	5.5	12.0	4.5
5x4.6	5.7	5.7	12.0	5.5	12.0	5.1
5x5.5	5.7	5.7	12.0	5.5	12.0	5.8
5x6.3	5.7	5.7	12.0	5.5	12.0	6.6
6.3x4	7.0	7.0	16.0	7.5	12.0	4.5
6.3x4.6	7.0	7.0	16.0	7.5	12.0	5.1
6.3x5.5	7.0	7.0	16.0	7.5	12.0	5.8
6.3x6.3	7.0	7.0	16.0	7.5	12.0	6.6
6.3x8	7.0	7.0	16.0	7.5	12.0	8.3
8x10.5	8.7	8.7	24.0	11.5	16.0	11.1
10x10.5	10.7	10.7	24.0	11.5	16.0	11.2
10x14	10.7	10.7	32.0	14.2	20.0	14.5
10x18	10.7	10.7	32.0	14.2	20.0	18.5
10x22	10.7	10.7	32.0	14.2	20.0	22.5
12.5x14	13.2	13.2	32.0	14.2	24.0	14.2
12.5x17	14.0	14.0	32.0	14.2	24.0	17.5
12.5x22	14.0	14.0	32.0	14.2	24.0	22.5
16x17	17.5	17.5	44.0	20.2	28.0	17.5
16x22	17.5	17.5	44.0	20.2	28.0	22.5
18x17	19.5	19.5	44.0	20.2	32.0	17.5
18x22	19.5	19.5	44.0	20.2	32.0	22.5

330mm (13") REEL STANDARD 380mm (15") REEL OPTIONAL

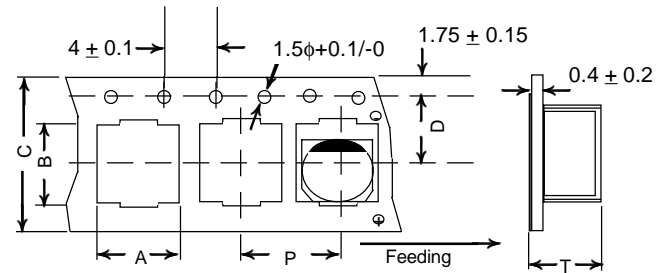

Case Size	W \pm 1	Quantity Per Reel	
		13" Reel (Std.)	15" Reel (Opt.)
3x5.5	14.0	1,500 pcs	2,000 pcs
4x4	14.0	1,500 pcs	2,000 pcs
4x4.6	14.0	1,500 pcs	2,000 pcs
4x5.5	14.0	1,500 pcs	2,000 pcs
4x6.3	14.0	1,200 pcs	2,000 pcs
5x4	14.0	1,000 pcs	1,000 pcs
5x4.6	14.0	1,000 pcs	1,000 pcs
5x5.5	14.0	1,000 pcs	1,000 pcs
5x6.3	14.0	800 pcs	1,000 pcs
6.3x4	18.0	1,000 pcs	1,000 pcs
6.3x4.6	18.0	1,000 pcs	1,000 pcs
6.3x5.5	18.0	1,000 pcs	1,000 pcs
6.3x6.3	18.0	800 pcs	1,000 pcs
6.3x8	18.0	500 pcs	900 pcs
8x10.5	26.0	300 pcs	500 pcs
10x10.5	26.0	300 pcs	500 pcs
10x14	34.0	250 pcs	300 pcs
10x18	34.0	250 pcs	300 pcs
10x22	34.0	250 pcs	300 pcs
12.5x14	34.0	200 pcs	250 pcs
12.5x17	34.0	150 pcs	200 pcs
12.5x22	34.0	125 pcs	150 pcs
16x17	46.0	125 pcs	150 pcs
16x22	46.0	75 pcs	100 pcs
18x17	46.0	125 pcs	150 pcs
18x22	46.0	75 pcs	100 pcs

REEL

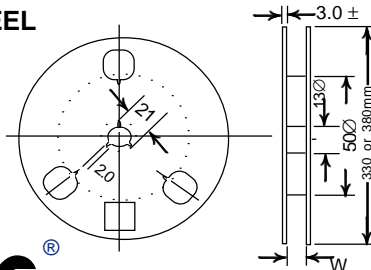

Surface Mount Aluminum Electrolytic Capacitors

RECOMMENDED LAND PATTERN (mm)

Case Dia.	a	b	c	d	e	f
3	0.8	2.2	1.6	-	-	-
4	1.0	2.6	1.6	-	-	-
5	1.4	3.0	1.6	-	-	-
6.3	2.1	3.0	1.6	-	-	-
8	2.8	4.15	1.9	-	-	-
10 x 10.5	4.3	4.4	1.9	-	-	-
10 x 14	4.0	4.5	2.0	-	-	-
10 x 18	4.0	4.5	2.0	-	-	-
10 x 22	4.0	4.5	2.0	-	-	-
12.5 x 14	4.3	5.65	2.1	-	-	-
12 x 17	4.0	5.7	2.0	-	-	-
12 x 22	4.0	5.7	2.0	-	-	-
16 (4 terminal)	6.0	6.5	2.5	8.5	11.0	18.0
18 (4 terminal)	6.0	7.5	2.5	8.5	13.0	20.0

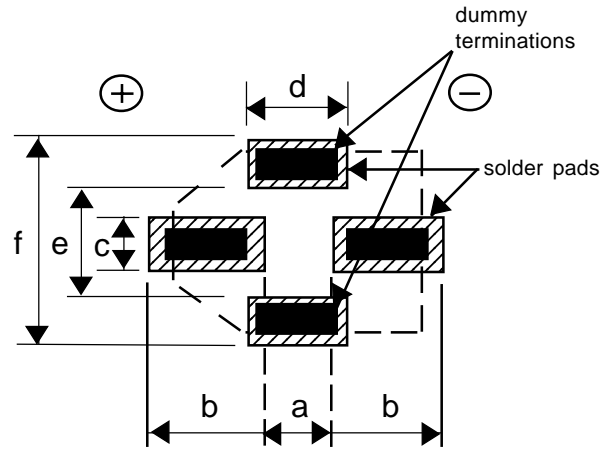

SURFACE MOUNT

PERMISSIBLE REFLOW TEMPERATURE PROFILE

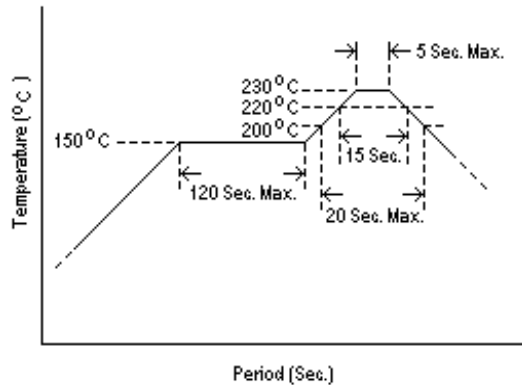

APPLICATION/PROCESSING GUIDELINES

1. Polarity: NACE, NACEW, NACZ, NACZF, NACX, NACS, NACP, NACT, NACH, NACV, NACVF and NACL series capacitors have polarity. Cathode is identified by black band on top of can. NACEN series is non-polar and can be used where circuit polarity is reversible or unknown.
2. Cleaning: A.) Freon TE, TES, TP-35; 2 minutes maximum at 40°C.
B.) CFC substitute solvents; 2 minutes maximum 60°C.
Post cleaning water wash (3-5 minutes) is recommended.
3. Soldering: only REFLOW soldering is applicable. The maximum recommended reflow soldering profile is shown at left.
The maximum temperature-time limits are as follows:

TEMPERATURE	MAXIMUM EXPOSURE TIME
+200°C	20 seconds
+220°C	15 seconds
+230°C	5 seconds

Please review soldering conditions outside these limits with NIC.



Surface Mount Specialty Polymer Solid Aluminum Electrolytic Capacitors

NSP Series

FEATURES

- VERY LOW IMPEDANCE AND HIGH RIPPLE AT 100KHZ
- FLAT TOP RESIN PACKAGE
- REPLACES MULTIPLE TANTALUM CHIPS IN HIGH CURRENT POWER SUPPLIES AND VOLTAGE REGULATOR APPLICATIONS
- FITS EIA (7343) "D" AND "E" TANTALUM CHIP LAND PATTERN
- COMPATIBLE WITH REFLOW SOLDERING



CHARACTERISTICS

Rated Voltage Range	2.0 ~ 16VDC		
Rated Capacitance Range	2.2 ~ 270 μ F		
Operating Temperature Range	-40 ~ 105°C		
Capacitance Tolerance	+/-20%(M)		
Max. Leakage Current (μ A) After 2 Minutes (+20°C)	D1 - D2	0.04CV or 3 μ A, whichever is greater	
	D3 - D4	0.06CV	
Max. Tan δ , 120Hz, +20°C	D1 - D2	0.06	
	D3 - D4	0.10	
High Temperature Load Life 1000 Hours At +105°C At Rated WVDC	Capacitance Change	Within +/-10% of initial measured value	
	Tan δ	Less than specified max. value	
	Leakage Current	Less than specified max. value	
Damp Heat Test 500 Hours At +60°C at 90-95%RH At Rated WVDC	Capacitance Change	6.3V-16V	Within -20%/+50% of initial measured value
		4V	Within -20%/+60% of initial measured value
		2V	Within -20%/+70% of initial measured value
	Tan δ	Less than 200% of specified max. value	
Leakage Current	Less than specified max. value		

STANDARD PRODUCTS AND SPECIFICATIONS

NIC Part Number	WV	Cap.	Max. LC	Tan δ	Max. Ripple Current +105°C & 100Khz (mA)	Max. Impedance +20°C & 400Khz (Ω)	Max. ESR +20°C & 100Khz (Ω)	Height H \pm 0.1
	(Vdc)	(μ F)	(μ A)					
NSP101M2D2TR	2.0	100	8.0	0.08	1600	0.04	-	1.8
NSP181M2D3TR	2.0	180	21.6	0.10	2000	-	0.03	3.1
NSP271M2D3TR	2.0	270	32.4	0.10	2000	-	0.025	3.1
NSP820M2.5D2TR	2.5	82	8.2	0.08	1600	0.04	-	1.8
NSP560M4D2TR	4.0	56	9.0	0.08	1600	0.04	-	1.8
NSP121M4D3TR	4.0	120	28.8	0.10	2000	-	0.03	3.1
NSP181M4D4TR	4.0	180	43.2	0.10	2000	-	0.025	4.2
NSP100M6.3D2TR	6.3	10	3.0	0.06	1000	0.13	-	1.8
NSP220M6.3D2TR	6.3	22	5.5	0.06	1300	0.09	-	1.8
NSP330M6.3D1TR	6.3	33	8.3	0.06	1600	0.06	-	1.5
NSP470M6.3D2TR	6.3	47	11.8	0.06	1600	0.05	-	1.8
NSP101M6.3D3TR	6.3	100	37.8	0.10	2000	-	0.03	3.1
NSP151M6.3D4TR	6.3	150	56.7	0.10	2000	-	0.025	4.2
NSP8R2M8D2TR	8	8.2	3.0	0.06	1000	0.14	-	1.8
NSP150M8D2TR	8	15	4.8	0.06	1300	0.11	-	1.8
NSP220M8D2TR	8	22	7.0	0.06	1600	0.09	-	1.8
NSP330M8D2TR	8	33	10.6	0.06	1600	0.06	-	1.8
NSP4R7M12.5D2TR	12.5	4.7	3.0	0.06	1000	0.18	-	1.8
NSP100M12.5D2TR	12.5	10	4.0	0.06	1000	0.13	-	1.8
NSP150M12.5D1TR	12.5	15	6.0	0.06	1300	0.11	-	1.5
NSP220M12.5D2TR	12.5	22	8.8	0.06	1600	0.09	-	1.8
NSP2R2M16D2TR	16	2.2	3.0	0.06	1000	0.26	-	1.8
NSP4R7M16D2TR	16	4.7	3.0	0.06	1000	0.18	-	1.8
NSP6R8M16D1TR	16	6.8	4.4	0.06	1000	0.15	-	1.5
NSP8R2M16D2TR	16	8.2	5.2	0.06	1000	0.14	-	1.8

RIPPLE CURRENT CORRECTION FACTOR OVER FREQUENCY

Frequency (Hz)	10Khz	20Khz	50Khz	100Khz	250Khz	500Khz	1Mhz
Correction Factor +25°C ~ +105°C	0.6	0.7	0.8	1.0	1.1	1.2	1.3

PART NUMBERING SYSTEM

NSP 100 M 12.5 D1 TR

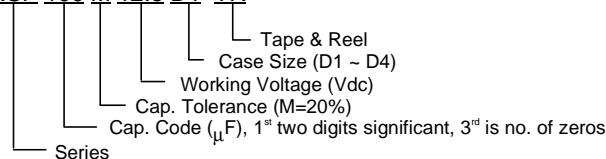

Surface Mount Specialty Polymer Solid Aluminum Electrolytic Capacitors

NSP Series

DIMENSIONS (mm)

Case Code	L +0.4	W +0.3	H	W1 +0.2	S +0.3
D1- D4	7.3	4.3	see specifications table	2.4	1.3

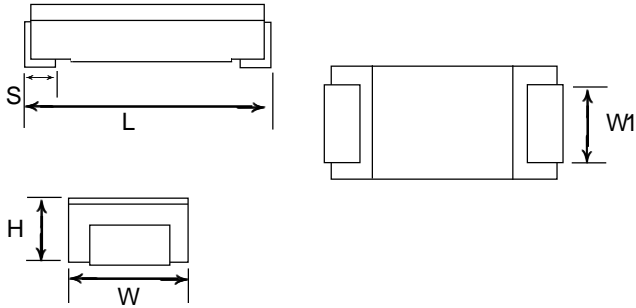

VOLTAGE CODES

Voltage	Code
2.0VDC	D
2.5VDC	E
6.3VDC	J
8VDC	K
12.5VDC	A
16VDC	C

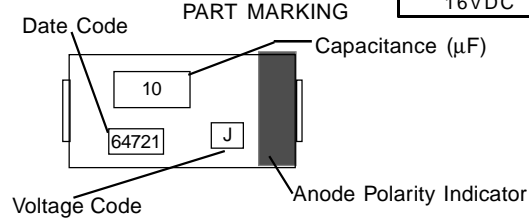

RECOMMENDED LAND PATTERNS (mm)

Case Code	A	B	C
D1-D4	2.8	4.0	8.8

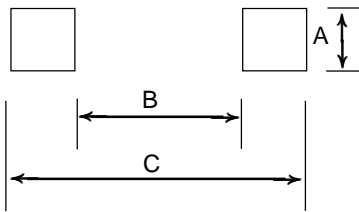

Please note the NSP series will fit on standard "D" and "E" size (7343) tantalum chip capacitor land patterns

RECOMMENDED REFLOW SOLDERING PROFILE

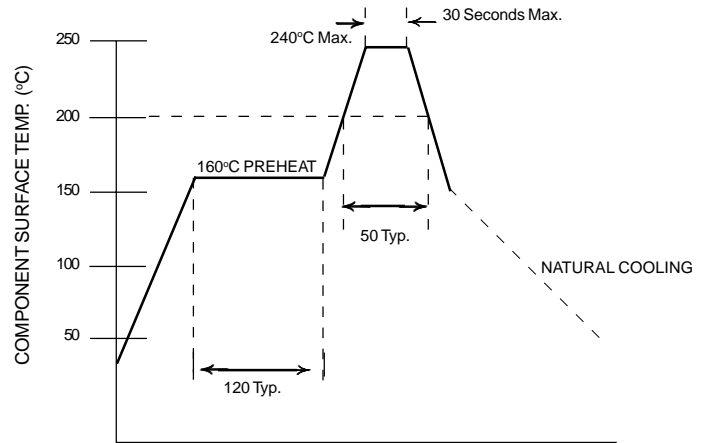

TYPICAL IMPEDANCE OVER FREQUENCY CHARACTERISTICS NSP SERIES

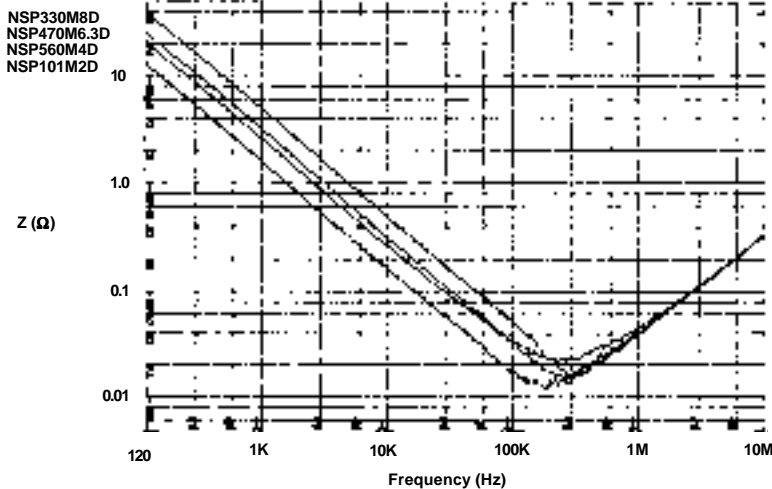

TIME (SECONDS)

TAPE DIMENSIONS (mm)

Case Code	A ± 0.2	B ± 0.2	D _φ	E ± 0.1	F ± 0.1	P ₁ ± 0.1	P ₂ ± 0.1	t ± 0.2	W ± 0.3
D1-D2								2.1	
D3	7.7	4.6	1.5 ^{+0.1}	1.75	5.5	4.0	8.0	3.4	12.0
D4								4.5	

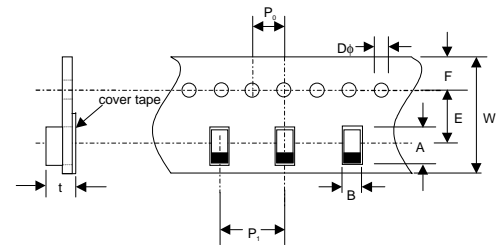

REEL TAPE DIMENSIONS (mm)

A ± 2.0	B min.	C ± 0.5	D ± 0.8	E ± 0.5	T ± 1.0	t	W ± 1.0
330	50	13.0	21.0	2.0	20.0	3.0	14

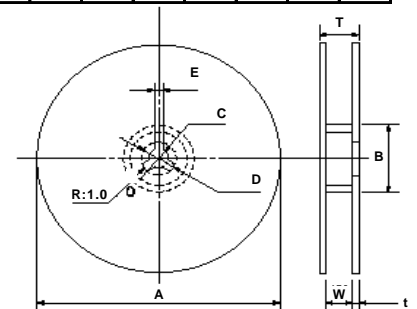

Case Code	Reel Quantity
D1-D2	3,500
D3-D4	2,000

SURFACE MOUNT

FEATURES

- NEW GENERATION HORIZONTAL MOUNT CHIP
- FLAT TOP RESIN PACKAGE FOR EASY PICK AND PLACEMENT
- EPOXY SEALED FOR EXTENDED LIFE (2000 HOURS AT +105°C)
- LOW IMPEDANCE AND HIGH RIPPLE AT 100KHZ
- FIXED TERMINALS FOR HIGH MECHANICAL STABILITY
- COMPATIBLE WITH REFLOW SOLDERING



CHARACTERISTICS

Rated Voltage Range	6.3 ~ 50VDC					
Rated Capacitance Range	0.47 ~ 100μF					
Operating Temperature Range	-55 ~ 105°C					
Capacitance Tolerance	+/-20%(M)					
Max. Leakage Current After 2 Minutes	0.01CV or 3μA, whichever is greater					
Working Voltage	WV (VDC)	6.3	10	16	25	50
Surge Voltage	SV (VDC)	7	13	20	32	63
Max. Tan δ	120Hz, +20°C	0.24	0.20	0.16	0.14	0.12
Low Temperature Stability (Impedance Ratio @ 120Hz)	WV (VDC)	6.3	10	16	25	50
	Z-25°C/+20°C	4	3	2	2	2
	Z-55°C/+20°C	10	8	6	4	4
High Temperature Load Life 2000 Hours at +105°C	Capacitance Change	Within + 30% of initial measured value				
	Tan δ	Less than 200% of specified max. value				
	Leakage Current	Less than specified max. value				
Rated WVDC						

STANDARD PRODUCTS AND CASE SIZE WxL (mm)

Capacitance (μF)	Code	Working Voltage (Vdc)				
		6.3	10	16	25	50
0.47	R47					3.8 x 6.5
1.0	1R0					3.8 x 6.5
1.5	1R5					3.8 x 6.5
2.2	2R2					3.8 x 6.5
3.3	3R3				3.8 x 6.5	4.8 x 7.3
4.7	4R7				3.8 x 6.5	4.8 x 7.3
6.8	6R8				3.8 x 6.5	4.8 x 7.3
10	100				3.8 x 6.5	4.8 x 7.3
15	150			3.8 x 6.5	4.8 x 7.3	
22	220		3.8 x 6.5		4.8 x 7.3	
33	330	3.8 x 6.5			4.8 x 7.3	
47	470			4.8 x 7.3		
68	680		4.8 x 7.3			
100	101	4.8 x 7.3				

MAXIMUM ESR (Ω) @ 20°C AND 120Hz

Capacitance (μF)	Working Voltage (Vdc)				
	6.3	10	16	25	50
0.47					423
1.0					199
1.5					133
2.2					90.4
3.3				70.4	60.3
4.7				49.3	42.3
6.8				34.1	29.3
10				23.2	19.9
15			17.7	15.5	
22			15.1	10.6	
33	12.1			7.03	
47			5.64		
68			4.88		
100	3.98				

STANDARD PRODUCTS

NIC Part Number	WV (VDC)	Cap. (μF)	Case Size WxHxL (mm)	Max. L.C. (μA)	Tan δ	Max. Ripple Current At +105°C & 100KHZ (mA)	Max. Impedance At +20°C & 100KHZ (Ω)
NACM330M6.3V3.8X6.5TR	6.3	33	3.8x3.8x6.5	3.0	0.24	30	6.5
NACM101M6.3V4.8X7.3TR	6.3	100	4.8x4.8x7.3	6.3	0.24	75	2.5
NACM220M10V3.8X6.5TR	10	22	3.8x3.8x6.5	3.0	0.20	30	6.5
NACM680M10V4.8X7.3TR	10	68	4.8x4.8x7.3	6.8	0.20	75	2.5
NACM150M16V3.8X6.5TR	16	15	3.8x3.8x6.5	3.0	0.16	30	6.5
NACM470M16V4.8X7.3TR	16	47	4.8x4.8x7.3	7.5	0.16	75	2.5
NACM3R3M25V3.8X6.5TR	25	3.3	3.8x3.8x6.5	3.0	0.14	15	6.5
NACM4R7M25V3.8X6.5TR	25	4.7	3.8x3.8x6.5	3.0	0.14	18	6.5
NACM6R8M25V3.8X6.5TR	25	6.8	3.8x3.8x6.5	3.0	0.14	22	6.5
NACM100M25V3.8X6.5TR	25	10	3.8x3.8x6.5	3.0	0.14	30	6.5
NACM150M25V4.8X7.3TR	25	15	4.8x4.8x7.3	3.7	0.14	65	2.5
NACM220M25V4.8X7.3TR	25	22	4.8x4.8x7.3	5.5	0.14	70	2.5
NACM330M25V4.8X7.3TR	25	33	4.8x4.8x7.3	8.2	0.14	75	2.5
NACMR47M50V3.8X6.5TR	50	0.47	3.8x3.8x6.5	3.0	0.12	5	7.0
NACM1R0M50V3.8X6.5TR	50	1.0	3.8x3.8x6.5	3.0	0.12	6	7.0
NACM1R5M50V3.8X6.5TR	50	1.5	3.8x3.8x6.5	3.0	0.12	8	7.0
NACM2R2M50V3.8X6.5TR	50	2.2	3.8x3.8x6.5	3.0	0.12	11	7.0
NACM3R3M50V3.8X6.5TR	50	3.3	3.8x3.8x6.5	3.0	0.12	25	7.0
NACM4R7M50V4.8X7.3TR	50	4.7	4.8x4.8x7.3	3.0	0.12	60	3.0
NACM6R8M50V4.8X7.3TR	50	6.8	4.8x4.8x7.3	3.4	0.12	65	3.0
NACM100M50V4.8X7.3TR	50	10	4.8x4.8x7.3	5.0	0.12	70	3.0

SURFACE MOUNT

DIMENSIONS (mm)

Case Size	W Max.	H Max.	L Max.	P +/-0.3
3.8 x 6.5	3.8	3.8	6.5	3.0
4.8 x 7.3	4.8	4.8	7.3	4.0

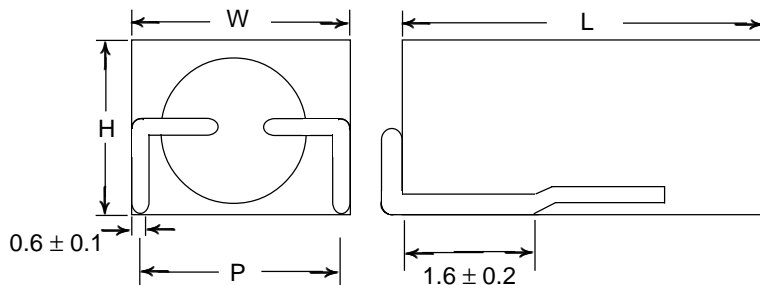

COMPONENT MARKING:

NOTCH IN BODY IDENTIFIES CATHODE

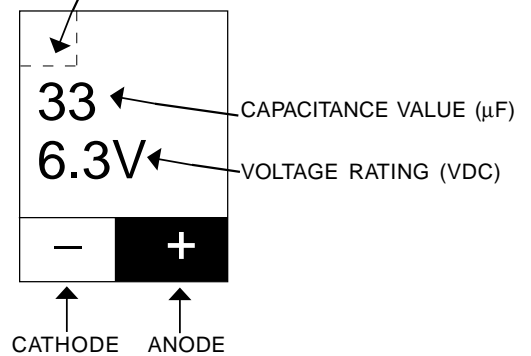

PART NUMBERING SYSTEM

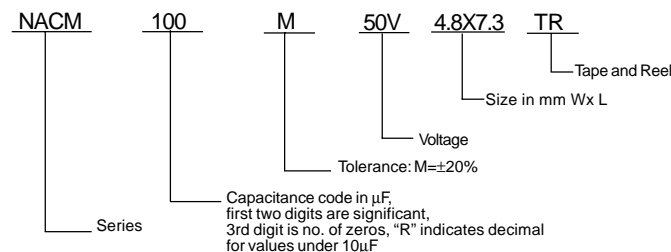

RECOMMENDED REFLOW SOLDERING PROFILE

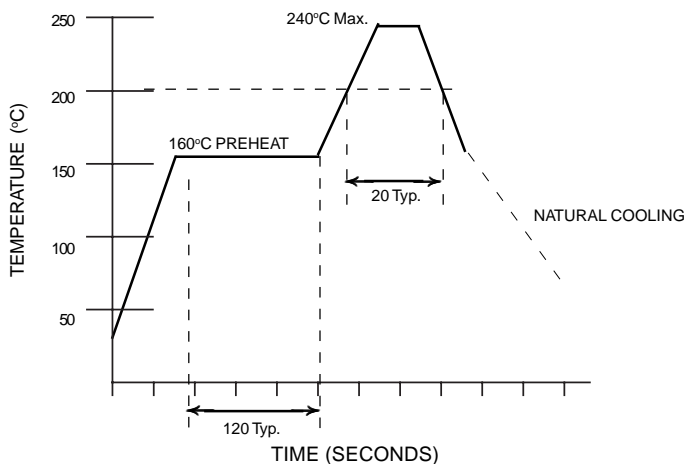

RECOMMENDED LAND PATTERNS (mm)

Case Size	A	B	C
3.8 x 6.5	1.1	2.4	2.0
4.8 x 7.3	1.1	2.4	3.0

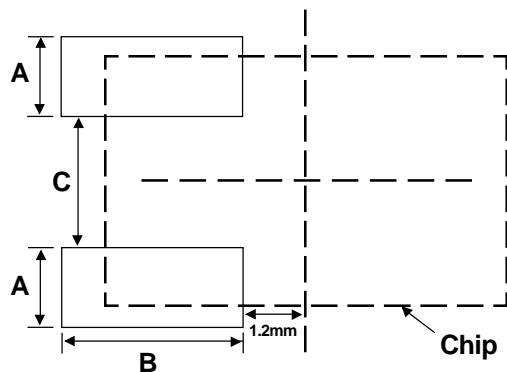

TAPING SPECIFICATIONS (mm)

Case Size	W \pm 0.2	A \pm 0.1	B \pm 0.2	C \pm 0.1	P \pm 0.1	F \pm 0.05	W1 \pm 0.5	Reel Qty.
3.8x3.8x6.5	12.0	6.8	4.2	4.0	8.0	5.5	13.5	3000
4.8x4.8x7.3	16.0	7.4	5.2	5.1	8.0	7.5	17.5	2000

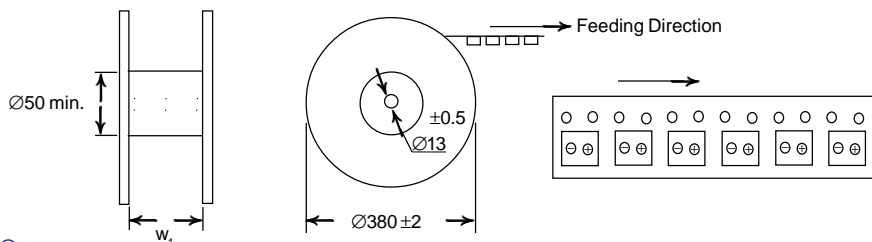
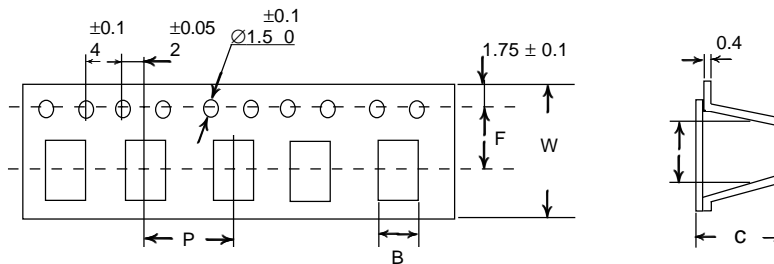

Surface Mount Aluminum Electrolytic Capacitors

NACE Series

FEATURES

- LOW COST, GENERAL PURPOSE, 2000 HOURS AT 85°C
- NEW EXPANDED CV RANGE (up to 6800μF)
- ANTI-SOLVENT (2 MINUTES)
- DESIGNED FOR AUTOMATIC MOUNTING AND REFLOW SOLDERING

CHARACTERISTICS

Rated Voltage Range	4.0 ~ 100 Vdc
Rated Capacitance Range	0.1 ~ 6800μF
Operating Temp. Range	-40 ~ +85°C
Capacitance Tolerance	±20%(M), ±10%(K)**
Max. Leakage Current After 2 Minutes @ 20°C	0.01CV or 3μA, whichever is greater



Tanδ @ 120Hz/20°C	W.V. (Vdc)	4.0	6.3	10	16	25	35	50	63	100	
	3mm Dia.	0.40	0.30	0.24	0.19	0.16	0.14	0.14	-	-	
	4 ~ 6.3 mm Dia.	0.35	0.26	0.20	0.16	0.14	0.12	0.10	0.10	0.10	
	8mm Dia ~ up	C < 1000μF	0.40	0.30	0.24	0.20	0.16	0.14	0.12	0.12	0.10
		C = 1500μF	-	0.31	0.25	0.21	-	0.15	-	-	-
		C = 2200μF	-	0.32	0.32	-	0.18	-	-	-	-
		C = 3300μF	-	0.34	-	0.24	-	-	-	-	-
C = 4700μF		-	-	0.36	-	-	-	-	-	-	
Low Temperature Stability Impedance Ratio @ 120Hz	W.V. (Vdc)	4.0	6.3	10	16	25	35	50	63	100	
	Z-25°C/Z +20°C	7	3	3	2	2	2	2	2	2	
	Z-40°C/Z +20°C	15	8	6	4	4	3	3	3	3	
Load Life Test 85°C 2,000 Hours	Capacitance Change	Within ±25% of initial measured value									
	Tanδ	Less than 200% of specified max. value									
	Leakage Current	Less than specified max. value									

MAXIMUM E.S.R. (Ω) AT 20°C AND 120Hz

(μF)	Working Voltage (Vdc)								
	4.0	6.3	10	16	25	35	50	63	100
0.1	-	-	-	-	-	-	1660	1660	-
0.22	-	-	-	-	-	-	754	754	-
0.33	-	-	-	-	-	-	503	503	-
0.47	-	-	-	-	-	-	353	353	-
1.0	-	-	-	-	-	-	166	166	166
2.2	-	-	-	-	-	90.4	75.4	75.4	75.4
3.3	-	-	-	-	-	60.3	50.3	50.3	50.3
4.7	-	-	-	-	4.94	42.3	35.3	35.3	35.3
10	-	-	-	26.5	23.2	19.9	16.6	16.6	16.6
22	30.1	18.1	15.1	12.1	10.6	9.05	7.54	7.54	7.54
33	17.6	12.6	10.1	8.04	7.04	6.04	5.03	6.04	5.03
47	12.4	8.47	7.06	5.65	4.95	4.24	3.53	4.24	-
68	8.54	5.86	4.88	3.91	3.42	2.93	2.44	-	-
100	5.80	3.98	3.32	2.66	2.32	1.99	1.99	1.99	-
150	3.87	2.66	2.21	1.77	1.55	1.33	-	-	1.11
220	2.64	1.96	1.51	1.21	1.21	1.06	0.91	0.91	-
330	1.76	1.31	1.21	1.01	0.81	0.71	-	-	-
470	1.42	1.06	0.85	0.71	0.57	-	-	0.43	-
680	-	0.59	-	0.49	-	0.34	-	-	-
1000	0.67	0.50	0.40	-	0.27	-	0.20	-	-
1500	-	0.35	-	0.24	-	0.17	-	-	-
2200	-	-	0.24	-	0.14	-	-	-	-
3300	-	0.17	-	0.12	-	-	-	-	-
4700	-	-	0.13	-	-	-	-	-	-
6800	-	0.10	-	-	-	-	-	-	-

MAXIMUM RIPPLE CURRENT (mA rms AT 120Hz AND 85°C)

Cap (μF)	Working Voltage (Vdc)								
	4.0	6.3	10	16	25	35	50	63	100
0.1	-	-	-	-	-	-	1.0	1.0	-
0.22	-	-	-	-	-	-	2.3	2.3	-
0.33	-	-	-	-	-	-	3.5	3.5	-
0.47	-	-	-	-	-	-	4.0*	5.0	-
1.0	-	-	-	-	-	-	8*	10	10
2.2	-	-	-	-	-	8*	15	15	20
3.3	-	-	-	-	-	10*	18	20	28
4.7	-	-	-	-	12*	19	20	23	35
10	-	-	-	20*	25	28	30	34	50
22	19*	31	35	39	52	54	58	70	120
33	26	39	43	57	63	60	85	160	190
47	34	47	59	68	68	70	90	170	330
68	52	63	66	75	80	110	120	-	-
100	61	71	76	86	130	130	200	280	-
150	74	78	88	135	200	220	-	-	560
220	82	95	150	150	250	270	320	410	-
330	80	150	280	280	310	340	-	-	-
470	150	300	300	330	430	-	-	700	-
680	-	300	-	450	-	610	-	-	-
1000	330	330	450	-	660	-	940	-	-
1500	-	450	-	710	-	1060	-	-	-
2200	-	-	730	-	1150	-	-	-	-
3300	-	750	-	1200	-	-	-	-	-
4700	-	-	1260	-	-	-	-	-	-
6800	-	1330	-	-	-	-	-	-	-



NIC COMPONENTS CORPORATION

*3x5.5 Size
**Optional

70 Maxess Rd., Melville, NY 11747 • (516)396-7500 FAX (516)396-7575

SURFACE MOUNT

STANDARD PRODUCT AND CASE SIZE TABLE DØxL (mm)

Cap. (µF)	Code	Working Voltage (Vdc)									
		4.0	6.3	10	16	25	35	50	63	100	
0.1	R10							3x5.5 4x5.5	4x5.5		
0.22	R22							3x5.5 4x5.5	4x5.5		
0.33	R33							3x5.5 4x5.5	4x5.5		
0.47	R47							3x5.5 4x5.5	4x5.5		
1.0	1R0							3x5.5 4x5.5	4x5.5	4x6.3	
2.2	2R2							3x5.5	4x5.5	4x5.5	6.3x6.3
3.3	3R3							3x5.5	4x5.5	5x5.5	6.3x6.3
4.7	4R7					3x5.5 4x5.5	4x5.5	5x5.5	5x5.5	6.3x6.3	
10	100				3x5.5 4x5.5	5x5.5	5x5.5	6.3x5.5	6.3x5.5	6.3x8	
22	220	3x5.5	4x5.5	5x5.5	5x5.5	6.3x5.5	6.3x5.5	6.3x6.3	6.3x8	8x10.5	
33	330	4x5.5	5x5.5	5x5.5	6.3x5.5	6.3x5.5	6.3x6.3	6.3x8	8x10.5	10x10.5	
47	470	4x5.5	5x5.5	6.3x5.5	6.3x5.5	6.3x6.3	6.3x6.3	6.3x8	8x10.5	12.5x14	
68	680	5x5.5	6.3x5.5	6.3x5.5	6.3x5.5	6.3x6.3	6.3x8	8x10.5			
100	101	5x5.5	6.3x5.5	6.3x5.5	6.3x5.5	6.3x8	6.3x8	8x10.5	10x10.5		
150	151	6.3x5.5	6.3x5.5	6.3x6.3	6.3x8	8x10.5	8x10.5	10x8*		16x17	
220	221	6.3x5.5	6.3x6.3	6.3x8	6.3x8	8x10.5	8x10.5	10x10.5	12.5x14		
330	331	6.3x6.3	6.3x8	8x10.5	8x10.5	10x8*	8x10.5	10x10.5			
470	471	6.3x8	8x10.5	8x10.5	8x10.5	10x8*	8x10.5	10x10.5		16x17	
680	681		10x8*		10x10.5			12.5x14			
1000	102	10x8*	8x10.5	10x10.5			12.5x14		16x17		
1500	152		10x10.5		12.5x14			16x17			
2200	222			12.5x14		16x17					
3300	332		12.5x14		16x17						
4700	472			16x17							
6800	682		16x17								

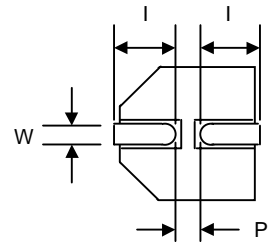
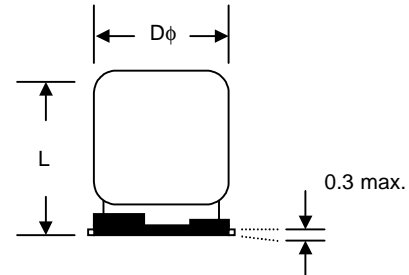

*Optional sizes

See page 166 for complete case size details

RIPPLE CURRENT CORRECTION FACTOR

Frequency Hz	100<F≤1K	1K<F≤10K	10K<F≤100K	F≥100K
C≤4.7µF	1.0	1.3	1.5	2.0
4.7µF<C≤33µF	1.0	1.2	1.3	1.45
C>33µF	1.0	1.1	1.2	1.3

PART NUMBERING SYSTEM

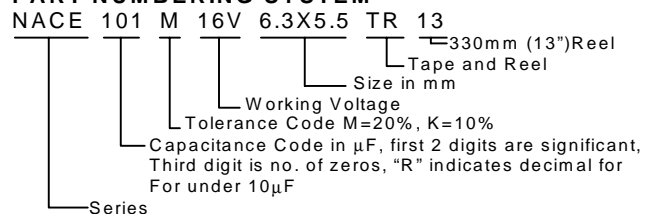

Surface Mount Aluminum Electrolytic Capacitors

NACP Series

FEATURES

- CYLINDRICAL LEADLESS TYPE FOR SURFACE MOUNTING
- LOW PROFILE, 4.6mm MAXIMUM HEIGHT
- DESIGNED FOR AUTOMATIC MOUNTING AND REFLOW SOLDERING

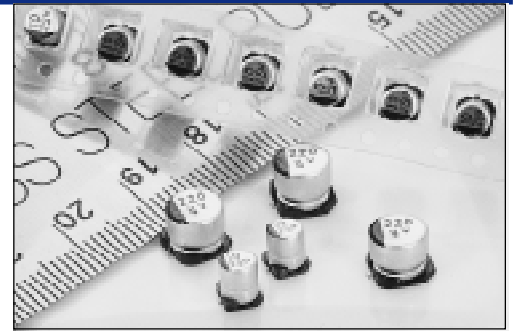

CHARACTERISTICS

Rated Voltage Range	4 ~ 50 Vdc							
Rated Capacitance Range	0.1 ~ 220 μ F							
Operating Temp. Range	-40° ~ +85°C							
Capacitance Tolerance	\pm 20%(M)							
Max. Leakage Current After 2 Minutes at 20°C	0.01CV or 3 μ A, whichever is greater							
Surge Voltage & Max. Tan δ	W.V. (Vdc)	4	6.3	10	16	25	35	50
	S.V. (Vdc)	5	8.0	13	20	32	44	63
	Tan δ @ 120Hz/20°C	0.40	0.30	0.24	0.20	0.16	0.14	0.12
Low Temperature Stability (Impedance Ratio @ 120Hz)	W.V. (Vdc)	4	6.3	10	16	25	35	50
	Z-25°C/Z+20°C	7	4	3	2	2	2	2
	Z-40°C/Z+20°C	15	10	8	6	4	4	4
Load Life Test at Rated W.V. 85°C 1,000 Hours	Capacitance Change	Within \pm 25% of initial value						
	Tan δ	Less than 200% of specified value						
	Leakage Current	Less than the specified value						

MAXIMUM PERMISSIBLE RIPPLE

CURRENT (mA rms AT 120Hz AND 85°C)

Cap (μ F)	Working Voltage (Vdc)						
	4	6.3	10	16	25	35	50
0.1							1.0
0.22							2.0
0.33							2.8
0.47							4.0
1.0							8.4
2.2							14
3.3							17
4.7					17	18	21
10				23	27	29	33
22		28	33	37	47	49	
33	28	37	41	51	57		
47	33	45	53	61			
100	56	70	74				
220	96						

MAXIMUM E.S.R. (Ω AT 20°C AND 120Hz)

Cap (μ F)	Working Voltage (Vdc)						
	4	6.3	10	16	25	35	50
0.1							1990
0.22							905
0.33							603
0.47							423
1.0							199
2.2						106	90.5
3.3					80.5	70.5	60.3
4.7				70.7	56.5	49.4	42.3
10			39.9	33.2	26.5	23.2	19.9
22	30.2	22.6	18.1	15.1	12.1		
33	20.1	15.1	12.6	10.1	8.1		
47	14.1	10.6	8.5	7.1			
100	6.6	5.0					
220	3.0						

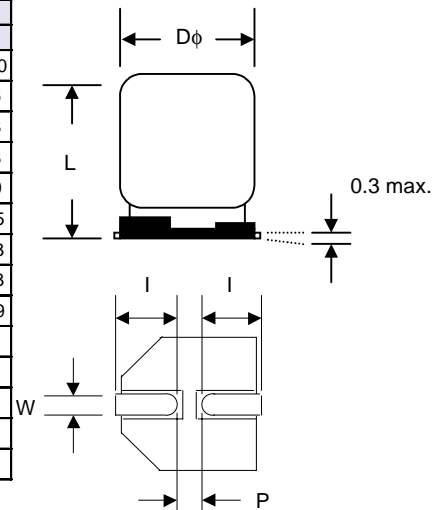

STANDARD PRODUCTION SIZE D ϕ xL (mm)

Cap (μ F)	Working Voltage (Vdc)						
	4	6.3	10	16	25	35	50
0.1							4x4.5
0.22							4x4.5
0.33							4x4.5
0.47							4x4.5
1.0							4x4.5
2.2							4x4.5
3.3							4x4.5
4.7					4x4.5	4x4.5	5x4.5
10				4x4.5	5x4.5	5x4.5	6.3x4.5
22		4x4.5	5x4.65	5x4.5	6.3x4.5	6.3x4.5	
33	4x4.5	5x4.5	5x4.5	6.3x4.5	6.3x4.5		
47	4x4.5	5x4.5	6.3x4.5	6.3x4.5			
100	5x4.5	6.3x4.5	6.3x4.5				
220	6.3x4.5						

DIMENSIONS (mm)

Case Size	D ϕ \pm 0.5	L \pm 0.1	A \pm 0.2	B \pm 0.2	I \pm 0.2	W	P \pm 0.2
4x4.5	4	4.5	4.3	4.3	1.8	0.5 ~ 0.8	1.0
5x4.5	5	4.5	5.3	5.3	2.1	0.5 ~ 0.8	1.4
6.3x4.5	6.3	4.5	6.6	6.6	2.5	0.5 ~ 0.8	2.2

RIPPLE CURRENT CORRECTION FACTOR

Cap (μ F)	Frequency			
	100~<1KHz	1K~<10KHz	10K~<100KHz	\geq 100K
0.47 ~ 4.7	1.0	1.3	1.5	2.0
10 ~ 33	1.0	1.2	1.3	1.45
47 ~ 220	1.0	1.1	1.2	1.3

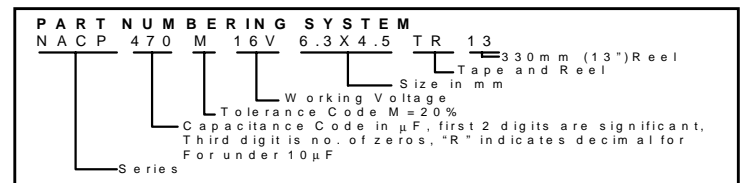

SURFACE MOUNT

FEATURES

- CYLINDRICAL LEADLESS TYPE FOR SURFACE MOUNTING
- LOW PROFILE, 5.5mm MAXIMUM HEIGHT
- REDUCED SIZES
- SPACE AND COST SAVINGS
- ANTI-SOLVENT (2 MINUTES)
- DESIGNED FOR AUTOMATIC MOUNTING AND REFLOW SOLDERING

CHARACTERISTICS

Rated Voltage Range	6.3 ~ 50 Vdc**						
Rated Capacitance Range	4.7 ~ 150 μ F						
Operating Temp. Range	-40° ~ +85°C						
Capacitance Tolerance	\pm 20%(M), \pm 10%(K)*						
Max. Leakage Current After 2 Minutes at 20°C	0.01CV or 3 μ A, whichever is greater						
Surge Voltage & Max. Tan δ	W.V. (Vdc)	6.3	10	16	25	35	50
	S.V. (Vdc)	8.0	13	20	32	44	63
	Tan δ @ 120Hz/20°C	0.28	0.24	0.20	0.16	0.14	0.12
Low Temperature Stability (Impedance Ratio @ 120Hz)	W.V. (Vdc)	6.3	10	16	25	35	50
	Z-40°C/Z +20°C	4	3	2	2	2	2
	Z-55°C/Z +20°C	10	8	6	4	4	4
Load Life Test at Rated W.V. 85°C 2,000 Hours	Capacitance Change	Within \pm 25% of initial measured value					
	Tan δ	Less than 200% of specified value					
	Leakage Current	Less than specified value					

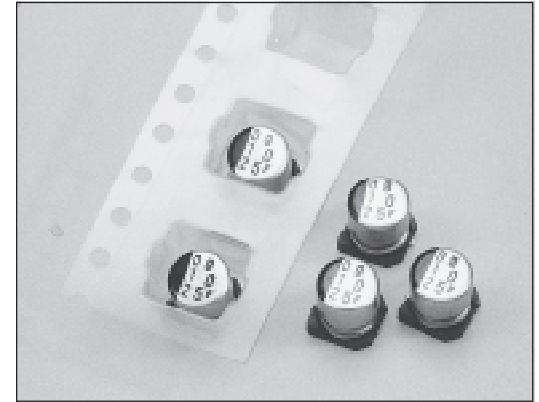

SURFACE MOUNT

* Optional \pm 10% (K) Tolerance available on most values. Contact factory for availability.

** For higher voltages, 200V and 400V, see NACV series.

MAXIMUM PERMISSIBLE RIPPLE

CURRENT (mA rms AT 120Hz AND 85°C) MAXIMUM E.S.R. (Ω AT 20°C AND 120Hz)

W.V. (Vdc) Cap (μ F)	6.3	10	16	25	35	50
4.7						18
10				20	20	27
22		28	28	35	36	40
33	31	32	40	42	65	
47	36	43	44	65		
56	46	46	48	68		
100	47	50				
150		76				

W.V. (Vdc) Cap (μ F)	6.3	10	16	25	35	50
4.7						42.3
10				26.5	23.2	19.9
22		18.1	15.1	12.1	10.6	9.05
33	14.1	12.6	10.1	8.04	7.04	
47	9.88	8.47	7.06	5.65		
56	8.29	7.11	5.92	4.74		
100	4.64	3.98				
150		2.66				

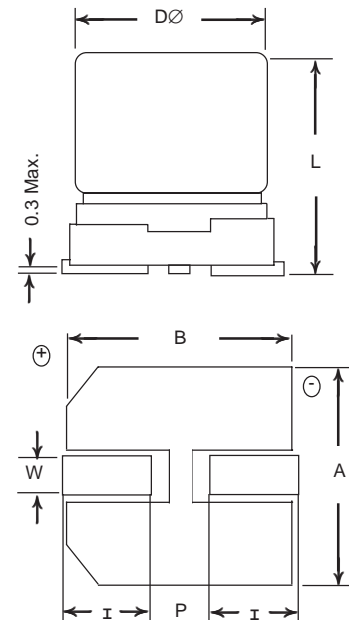

RIPPLE CURRENT CORRECTION FACTOR

Frequency Hz	50 \leq f < 100	100 \leq f < 1K	1K \leq f < 10K	f \geq 10K
Correction Factor	0.8	1.0	1.3	1.5

STANDARD PRODUCTION SIZE DØ xL (mm)

W.V. (Vdc) Cap (μ F)	Code	DØ xL (mm)					
		6.3	10	16	25	35	50
4.7	4R7						4x5.5
10	100						5x5.5
22	220		4x5.5	4x5.5	5x5.5	5x5.5	6.3x5.5
33	330	4x5.5	4x5.5	5x5.5	5x5.5	6.3x5.5	
47	470	4x5.5	5x5.5	5x5.5	6.3x5.5		
56	560	5x5.5	5x5.5	5x5.5	6.3x5.5		
100	101	5x5.5	5x5.5				
150	151		6.3x5.5				

DIMENSIONS (mm)

Case Size	DØ \pm 0.5	L MAX	A \pm 0.2	B \pm 0.2	I \pm 0.2	W	P \pm 0.2
4x5.5	4.0	5.5	4.3	4.3	1.8	0.5 - 0.8	1.0
5x5.5	5.0	5.5	5.3	5.3	2.1	0.5 - 0.8	1.4
6.3x5.5	6.3	5.5	6.6	6.6	2.5	0.5 - 0.8	2.2

PART NUMBERING SYSTEM

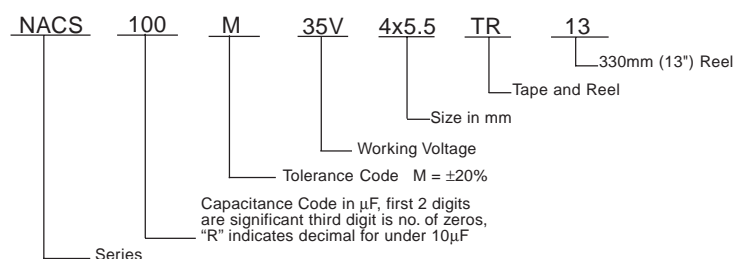

FEATURES

- CYLINDRICAL LEADLESS TYPE FOR SURFACE MOUNTING
- LOW LEAKAGE CURRENT (0.5μA TO 2.0μA max.)
- LOW COST REPLACEMENT FOR MANY TANTALUM APPLICATIONS
- DESIGNED FOR AUTOMATIC MOUNTING AND REFLOW SOLDERING

CHARACTERISTICS

Rated Voltage Range	6.3 ~ 50 Vdc						
Rated Capacitance Range	0.1 ~ 100μF						
Operating Temperature Range	-40° ~ +85°C						
Capacitance Tolerance	±20%(M)						
Max. Leakage Current After 2 Minutes at 20°C	0.002CV or 0.5μA, whichever is greater						
Surge Voltage & Max. Tanδ	W.V. (Vdc)	6.3	10	16	25	35	50
	S.V. (Vdc)	8.0	13	20	32	44	63
	Tanδ @ 120Hz/20°C	0.24	0.20	0.16	0.14	0.12	0.10
Low Temperature Stability (Impedance Ratio @ 120Hz)	W.V. (Vdc)	6.3	10	16	25	35	50
	Z-25°C/Z +20°C	4	3	2	2	2	2
	Z-40°C/Z +20°C	8	6	4	4	3	3
Load Life Test at Rated W.V. 85°C 2,000 Hours	Capacitance Change	Within ±25% of initial measured value					
	Tanδ at 120	Less than 200% of specified value					
	Leakage Current	Less than specified value					



SURFACE MOUNT

MAXIMUM PERMISSIBLE RIPPLE CURRENT (mA rms AT 120Hz AND 85°C) MAXIMUM E.S.R. (Ω AT 20°C AND 120Hz)

W.V. (Vdc) Cap (μF)	6.3	10	16	25	35	50
0.1						1.0
0.22						2.3
0.33						3.5
0.47						5
1.0						10
2.2						15
3.3						18
4.7				19	20	23
10			25	28	30	34
22	31	35	39	52	54	
33	39	43	57	63		
47	47	59	68			
100	71	76				

W.V. (Vdc) Cap (μF)	6.3	10	16	25	35	50
0.1						1660
0.22						754
0.33						503
0.47						353
1.0						166
2.2						75.4
3.3						50.3
4.7				49.5	42.3	35.3
10			26.5	23.2	19.9	16.6
22	18.1	15.1	12.1	10.6	9.05	
33	12.6	10.1	8.04	7.04		
47	8.47	7.06	5.65			
100	3.98	3.32				

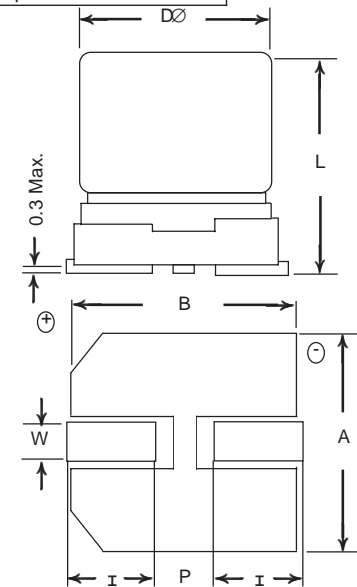

STANDARD PRODUCTION SIZE Dø xL (mm)

W.V. (Vdc) Cap (μF) Code	6.3	10	16	25	35	50
	0.1 R10					
0.22 R22						4x5.5
0.33 R33						4x5.5
0.47 R47						4x5.5
1.0 1R0						4x5.5
2.2 2R2						4x5.5
3.3 3R3						4x5.5
4.7 4R7				4x5.5	4x5.5	5x5.5
10 100			4x5.5	5x5.5	5x5.56	6.3x5.5
22 220	4x5.5	5x5.5	5x5.5	6.3x5.5	6.3x5.5	
33 330	5x5.5	5x5.5	6.3x5.5	6.3x5.5		
47 470	5x5.5	6.3x5.5	6.3x5.5			
100 101	5x5.5	6.3x5.5				

ripple current correction factor

Frequency Hz	50 ≤ f < 100	100 ≤ f < 1K	1K ≤ f < 10K	f ≥ 10K
Correction Factor	0.8	1.0	1.3	1.5

DIMENSIONS (mm)

Case Size	Dø ± 0.5	L MAX	A ± 0.2	B ± 0.2	I ± 0.2	W	P ± 0.2
4x5.5	4.0	5.5	4.3	4.3	1.8	0.5 ~ 0.8	1.0
5x5.5	5.0	5.5	5.3	5.3	2.1	0.5 ~ 0.8	1.4
6.3x5.5	6.3	5.5	6.6	6.6	2.5	0.5 ~ 0.8	2.2

PART NUMBERING SYSTEM

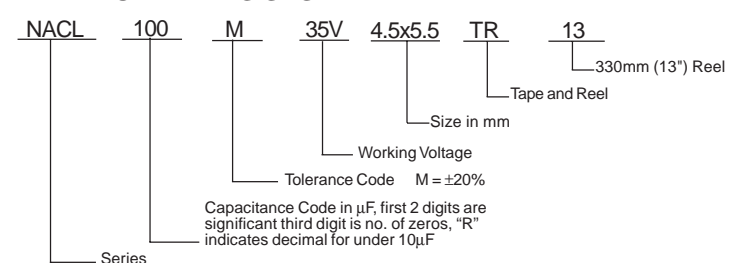

Surface Mount Aluminum Electrolytic Capacitors NACEW Series

FEATURES

- CYLINDRICAL LEADLESS TYPE FOR SURFACE MOUNTING
- WIDE TEMPERATURE -55 ~ +105°C WITH ECONOMICAL PRICING
- WIDE CV RANGE
- ANTI-SOLVENT (2 MINUTES)
- DESIGNED FOR AUTOMATIC MOUNTING AND REFLOW SOLDERING

CHARACTERISTICS

Rated Voltage Range	6.3 ~ 100 Vdc**								
Rated Capacitance Range	0.1 ~ 6800µF								
Operating Temperature Range	-55° ~ +105°C (100V -40° ~ +105°C)								
Capacitance Tolerance	±20%(M), ±10%(K)*								
Max. Leakage Current After 2 Minutes @ 20°C	0.01CV or 3µA, whichever is greater								
Surge Voltage	W.V. (Vdc)	6.3	10	16	25	35	50	63	100
	S.V. (Vdc)	8.0	13	20	32	44	63	79	125
Max. Tanδ @ 120 Hz/20°C	∅4-∅6.3	0.24	0.20	0.16	0.14	0.12	0.10	0.12	0.10
	∅8 & larger	0.28	0.24	0.20	0.16	0.14	0.12	0.12	0.10
Low Temperature Stability	W.V. (Vdc)	6.3	10	16	25	35	50	63	100
	Z-40°C/Z +20°C	3	3	2	2	2	2	2	3
Impedance Ratio @ 120Hz	Z-55°C/Z +20°C	8	5	4	3	3	3	3	-
Load Life Test 105°C 1,000 Hours	Capacitance Change	Within ± 25% of initial measured value							
	Tanδ	Less than 200% of specified value							
	Leakage Current	Less than specified value							



* Optional ± 10% (K) Tolerance - see case size chart.
** For higher voltages, 200V and 400V, see NACV series.

MAXIMUM E.S.R. (Ω AT 20°C AND 120Hz)

Cap (µF)	Working Voltage (Vdc)								
	6.3	10	16	25	35	50	63	100	
0.1	-	-	-	-	-	1660	1990	-	
0.22	-	-	-	-	-	754	905	-	
0.33	-	-	-	-	-	503	604	-	
0.47	-	-	-	-	-	353	424	-	
1.0	-	-	-	-	-	166	199	166	
2.2	-	-	-	-	-	75.4	90.5	75.4	
3.3	-	-	-	-	-	50.3	60.3	50.3	
4.7	-	-	-	49.4	42.3	35.3	42.4	35.3	
10	-	-	26.5	23.2	19.9	16.6	19.9	16.6	
22	18.1	15.1	12.1	10.6	9.05	7.64	9.04	7.64	
33	12.6	10.1	8.04	7.04	6.04	5.03	6.03	5.03	
47	8.47	7.06	5.65	4.95	4.24	3.53	4.24	3.53	
100	3.98	3.32	2.66	2.32	2.32	1.99	1.99	-	
150	2.66	2.21	1.77	1.77	1.55	-	-	1.10	
220	1.81	1.51	1.21	1.21	1.06	0.91	0.91	-	
330	1.21	1.21	1.00	0.80	0.70	-	-	-	
470	0.99	0.85	0.71	0.57	0.49	-	0.42	-	
1000	0.46	0.40	-	0.27	-	0.20	-	-	
1500	0.31	-	0.23	-	0.16	-	-	-	
2200	-	0.18	-	0.12	-	-	-	-	
3300	0.14	-	0.10	-	-	-	-	-	
4700	-	0.085	-	-	-	-	-	-	
6800	0.068	-	-	-	-	-	-	-	

MAXIMUM PERMISSIBLE RIPPLE CURRENT (mA rms AT 120Hz AND 105°C)

Cap (µF)	Working Voltage (Vdc)								
	6.3	10	16	25	35	50	63	100	
0.1	-	-	-	-	-	0.7	0.7	-	
0.22	-	-	-	-	-	1.6	1.6	-	
0.33	-	-	-	-	-	2.5	2.5	-	
0.47	-	-	-	-	-	3.5	3.5	-	
1.0	-	-	-	-	-	7.0	7.0	7.0	
2.2	-	-	-	-	-	11	11	14	
3.3	-	-	-	-	-	13	13	20	
4.7	-	-	-	13	14	16	16	25	
10	-	-	18	20	21	24	24	35	
22	22	25	27	36	38	38	49	84	
33	27	30	40	44	42	59	112	133	
47	33	41	48	47	49	63	119	240	
100	50	53	60	91	84	140	196	-	
150	55	62	95	140	155	-	-	500	
220	66	105	105	175	190	220	287	-	
330	105	195	195	220	300	-	-	-	
470	210	210	230	300	410	-	630	-	
1000	280	310	-	460	-	655	-	-	
1500	310	-	500	-	740	-	-	-	
2200	-	510	-	805	-	-	-	-	
3300	520	-	840	-	-	-	-	-	
4700	-	880	-	-	-	-	-	-	
6800	930	-	-	-	-	-	-	-	

RIPPLE CURRENT CORRECTION FACTOR

Frequency Hz	50 f<100	100 f<1K	1K f<10K	10K f≥100K
Correction Factor	0.8	1.0	1.3	1.5

PART NUMBERING SYSTEM

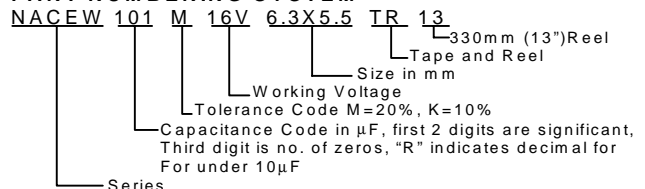

Surface Mount Aluminum Electrolytic Capacitors NACEW Series

STANDARD PRODUCT AND CASE SIZE TABLE DØxL (mm)

Cap. (µF)	Code	Working Voltage (Vdc)							
		6.3	10	16	25	35	50	63	100
0.1	R10	-	-	-	-	-	4x5.5*	4x5.5*	-
0.22	R22	-	-	-	-	-	4x5.5*	4x5.5*	-
0.33	R33	-	-	-	-	-	4x5.5*	4x5.5*	-
0.47	R47	-	-	-	-	-	4x5.5*	4x5.5*	-
1.0	1R0	-	-	-	-	-	4x5.5*	4x5.5*	4x6.3*
2.2	2R2	-	-	-	-	-	4x5.5*	4x5.5*	6.3x6.3*
3.3	3R3	-	-	-	-	-	4x5.5*	5x5.5*	6.3x6.3*
4.7	4R7	-	-	-	4x5.5*	4x5.5*	5x5.5*	5x5.5*	6.3x6.3*
10	100	-	-	4x5.5*	5x5.5*	5x5.5*	6.3x5.5*	6.3x5.5*	6.3x8*
22	220	4x5.5*	5x5.5*	5x5.5*	6.3x5.5*	6.3x5.5*	6.3x6.3*	6.3x8*	8x10.5*
33	330	5x5.5*	5x5.5*	6.3x5.5*	6.3x5.5*	6.3x6.3*	6.3x8*	8x10.5*	10x10.5*
47	470	5x5.5*	6.3x5.5*	6.3x5.5*	6.3x6.3*	6.3x6.3*	6.3x8*	8x10.5*	12.5x14
100	101	6.3x5.5*	6.3x5.5*	6.3x5.5*	6.3x8*	6.3x8	8x10.5*	10x10.5*	-
150	151	6.3x5.5*	6.3x6.3*	6.3x8*	8x10.5*	8x10.5* 10x8*	-	-	16x17
220	221	6.3x6.3*	6.3x8*	6.3x8*	8x10.5* 10x8*	8x10.5	10x10.5	12.5x14	-
330	331	6.3x8*	8x10.5*	8x10.5* 10x8	8x10.5*	10x10.5	-	-	-
470	471	8x10.5	8x10.5 10x8	8x10.5	10x10.5*	12.5x14	-	16x17	-
1000	102	8x10.5*	10x10.5*	-	12.5x14	-	16x17	-	-
1500	152	10x10.5*	-	12.5x14	-	16x17	-	-	-
2200	222	-	12.5x14	-	16x17	-	-	-	-
3300	332	12.5x14	-	16x17	-	-	-	-	-
4700	472	-	16x17	-	-	-	-	-	-
6800	682	16x17	-	-	-	-	-	-	-

*Denotes values that are available in optional 10% tolerance

DIMENSIONS (mm) and STANDARD REEL QUANTITIES

Case Size	DØ ± 0.5	L max.	A ± 0.2	B ± 0.2	l ± 0.2	W	P ± 0.2	Q'ty per Reel
3x5.5	3.0	5.5	3.3	3.3	1.5	0.45~0.75	0.6	1,500 pcs
4x5.5	4.0	5.5	4.3	4.3	1.8	0.5-0.8	1.0	1,500 pcs
5x5.5	5.0	5.5	5.3	5.3	2.1	0.5-0.8	1.4	1,000 pcs
6.3x5.5	6.3	5.5	6.6	6.6	2.5	0.5-0.8	2.2	1,000 pcs
6.3x6.3	6.3	6.3	6.6	6.6	2.5	0.5~0.8	2.2	800 pcs
6.3x8	6.3	8.0	6.6	6.6	2.5	0.5~0.8	2.2	500 pcs
8x10.5	8.0	10.5	8.3	8.3	2.9	0.7~1.0	3.2	300 pcs
10x10.5	10	10.5	10.3	10.3	3.2	0.7~1.0	4.6	300 pcs
12.5x14	12.5	14	12.8	12.8	4.45	0.7~1.0	4.6	250 pcs
16x17	16	17	16.3	16.3	5.0	1.8~2.1	7.0	150 pcs

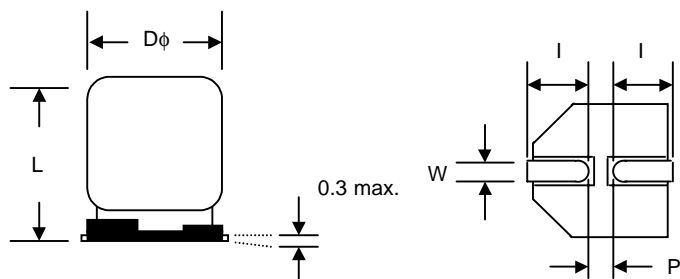

SURFACE MOUNT

FEATURES

- CYLINDRICAL LEADLESS TYPE FOR SURFACE MOUNTING
- WIDE TEMPERATURE -40° ~+105°C
- LONG LIFE (+105°C, 2000 HOURS)
- 6.3 mm MAXIMUM HEIGHT
- DESIGNED FOR AUTOMATIC MOUNTING AND REFLOW SOLDERING

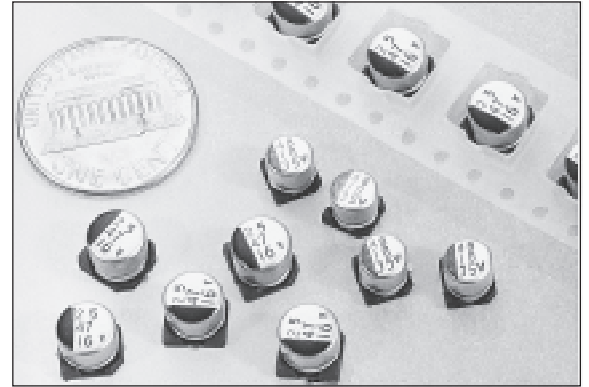

CHARACTERISTICS

Rated Voltage Range	4 ~ 50 Vdc	
Rated Capacitance Range	0.1 ~ 220µF	
Operating Temperature Range	-40° ~ +105°C	
Capacitance Tolerance	±20%(M), ±10%(K)*	
Max. Leakage Current After 2 Minutes @ 20°C	0.01CV or 3µA, whichever is greater	
Surge Voltage	W.V. (Vdc)	4 6.3 10 16 25 35 50
	S.V. (Vdc)	5 8.0 13 20 32 44 63
Max. Tanδ @ 120 Hz/20°C	∅4-∅6.3	.50 .30 .22 .16 .14 .12 .12
Low Temperature Stability	W.V. (Vdc)	4 6.3 10 16 25 35 50
	Z-40°C/Z +20°C	7 4 3 2 2 2 2
Impedance Ratio @ 120Hz	Z-55°C/Z +20°C	12 8 6 4 4 3 3
	Capacitance Change	Within ±25% of initial measured value
Load Life Test 105°C, 2,000 Hours	Tanδ	Less than 200% of specified value
	Leakage Current	Less than specified value

* Optional ± 10% (K) Tolerance available on most values. Contact factory for availability.

MAXIMUM E.S.R. (Ω AT 20°C AND 120Hz)

W.V. (Vdc) Cap (µF)	4.0	6.3	10	16	25	35	50
0.1							1993
0.22							906
0.33							604
0.47							424
1.0							199
2.2							90.6
3.3							60.4
4.7					49.5		42.4
10				26.6		19.9	19.9
22		22.6		12.1		9.05	
33		15.1	11.1		7.05		
47	17.7	10.6		5.66			
100	8.31	4.98					
220	3.77						

MAXIMUM PERMISSIBLE RIPPLE CURRENT (mA rms AT 120Hz AND 105°C)

W.V. (Vdc) Cap (µF)	4.0	6.3	10	16	25	35	50
0.1							1.0
0.22							2.0
0.33							3.0
0.47							5.0
1.0							10
2.2							16
3.3							16
4.7					22		23
10				28		28	35
22		26		39		55	
33		29	43		65		
47	34	46		70			
100	61	71					
220	82						

RIPPLE CURRENT CORRECTION FACTOR

Frequency Hz	50 ≤ f < 100	100 ≤ f < 1K	1K ≤ f < 10K	10K ≤ f < 100K
Correction Factor	0.8	1.0	1.3	1.5

STANDARD PRODUCT AND CASE SIZE TABLE DØxL (mm)

Cap (µF)	Code	W.V. (Vdc)						
		4.0	6.3	10	16	25	35	50
0.1	R10							4x6.3
0.22	R22							4x6.3
0.33	R33							4x6.3
0.47	R47							4x6.3
1.0	1R0							4x6.3
2.2	2R2							4x6.3
3.3	3R3							4x6.3
4.7	4R7					4x6.3		5x6.3
10	100				4x6.3		5x6.3	6.3x6.3
22	220		4x6.3		5x6.3		6.3x6.3	
33	330		4x6.3	5x6.3		6.3x6.3		
47	470	4x6.3	5x6.3		6.3x6.3			
100	101	5x6.3	6.3x6.3					
220	221	6.3x6.3						

DIMENSIONS (mm) and STANDARD REEL QUANTITIES

Case Size	DØ ± 0.5	L max.	A ± 0.2	B ± 0.2	I ± 0.2	W	P ± 0.2	Q'ty per Reel
4x6.3	4.0	6.3	4.3	4.3	1.8	0.5-0.8	1.0	1,500 pcs
5x6.3	5.0	6.3	5.3	5.3	2.1	0.5-0.8	1.4	1,000 pcs
6.3x6.3	6.3	6.3	6.6	6.6	2.4	0.5-0.8	2.2	800 pcs

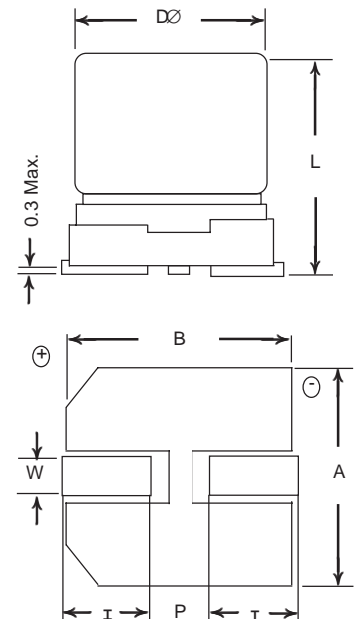
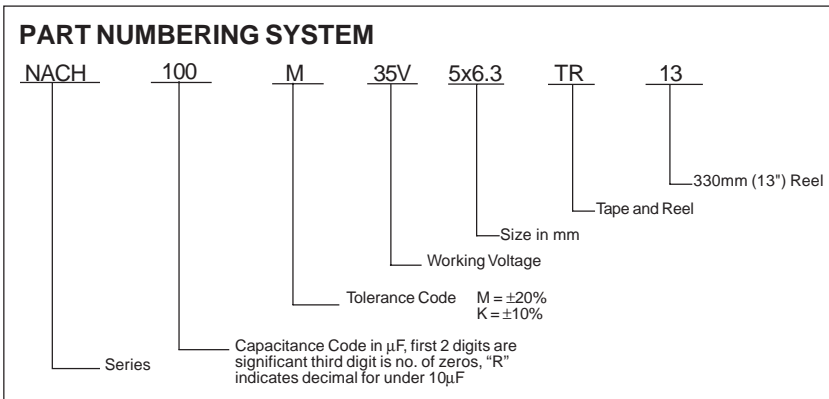

FEATURES

- CYLINDRICAL LEADLESS TYPE FOR SURFACE MOUNT
- HIGH VOLTAGE (200VDC AND 400VDC)
- 10 x10.8mm ~ 16 x17mm CASE SIZE
- LONG LIFE (2000 HOURS AT +105°C)
- COMPATIBLE WITH REFLOW SOLDERING



CHARACTERISTICS

Rated Voltage Range		200 Vdc	400 Vdc
Rated Capacitance Range		4.7 ~ 68μF	3.3 ~ 22μF
Operating Temperature Range		- 40°C ~ + 105°C	
Capacitance Tolerance		± 20% (M)	
Max. Leakage Current After 2 Minutes		0.03CV + 15μF	
Max. Tanδ		0.20	0.25
Low Temperature Stability (Impedance Ratio @ 120Hz)	Z-25°C/+20°C	3	6
	Z-55°C/+20°C	6	10
High Temperature Load Life 2000 Hours at +105°C Rated WVDC	Capacitance Change	Within ± 25% of initial value	
	Tan δ	Less than 200% of specified value	
	Leakage Current	Less than the specified value	

SPECIFICATIONS

NIC Part Number	WV (VDC)	Cap. (μF)	Max. L.C. (μA)	Max. Tan δ	Max. Ripple Current At +105°C & 120HZ (mA)	Max. ESR At +20°C & 120HZ (OHM)
NACV4R7M200V10X10.8TR	200	4.7	43	0.20	64	70.5
NACV100M200V10X10.8TR	200	10	65	0.20	64	33.1
NACV220M200V12.5X14TR	200	22	113	0.20	112	15.1
NACV330M200V12.5X14TR	200	33	157	0.20	112	10.0
NACV470M200V16X17TR	200	47	297	0.20	215	7.1
NACV680M200V16X17TR	200	68	423	0.20	215	4.9
NACV3R3M400V10X10.8TR	400	3.3	51	0.25	36	126.0
NACV4R7M400V10X10.8TR	400	4.7	63	0.25	36	88.1
NACV6R8M400V12.5X14TR	400	6.8	80	0.25	47	61.0
NACV100M400V12.5X14TR	400	10	105	0.25	47	41.5
NACV220M400V16X17TR	400	22	279	0.25	115	18.9

DIMENSIONS (mm) and STANDARD REEL QUANTITIES

Case Size	DØ ± 0.5	L max.	A ± 0.2	B ± 0.2	I ± 0.2	W	P ± 0.2	Q'ty per Reel
10x10.8	10.0	10.8	10.3	10.3	3.2	0.7-1.0	4.6	300 pcs
12.5x14	12.5	14.0	12.8	12.8	4.4	0.7-1.0	4.6	200 pcs
16x17	16.0	17	16.3	16.3	5.0	1.8~2.1	7.0	125 pcs

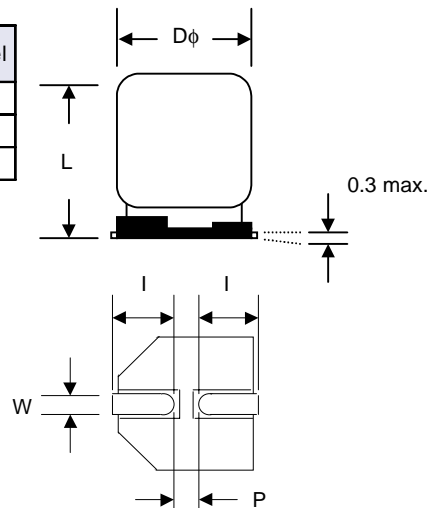

PART NUMBERING SYSTEM

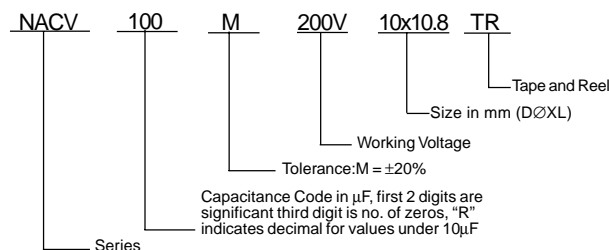

Surface Mount Aluminum Electrolytic Capacitors NACVF Series

FEATURES

- CYLINDRICAL LEADLESS TYPE FOR SURFACE MOUNT
- HIGH VOLTAGE (160VDC AND 450VDC)
- 10mm x 14mm ~ 18mm x 22mm Size
- 4 TERMINALS (16 & 18mm Dia.) FOR HIGH VIBRATION STABILITY
- LONG LIFE (5000 HOURS AT +105°C)
- COMPATIBLE WITH REFLOW SOLDERING



CHARACTERISTICS

Rated Voltage Range		160 ~ 450 Vdc					
Rated Capacitance Range		2.2 ~ 100μF					
Operating Temperature Range		- 40°C ~ + 105°C					
Capacitance Tolerance		± 20% (M)					
Max. Leakage Current After 2 Minutes		0.06CV + 10μF					
Max. Tanδ at 120Hz & 20°C		160Vdc	200Vdc	250Vdc	350Vdc	400Vdc	450Vdc
		0.15		0.20	0.24		
Low Temperature Stability (Impedance Ratio @ 120Hz)	Z-25°C/+20°C	2	2	3	5	6	6
	High Temperature Load Life 5000 Hours at +105°C	Within ± 20% of initial measured value					
Rated WVDC	Capacitance Change	Within ± 20% of initial measured value					
	Tan δ	Less than 200% of specified value					
	Leakage Current	Less than the specified maximum value					
Resistance to Soldering Heat Within the Recommended Reflow Conditions	Capacitance Change	Within ± 10% of initial measured value					
	Tan δ	Less than the specified maximum value					
	Leakage Current	Less than the specified maximum value					

SURFACE MOUNT

STANDARD PRODUCT AND CASE SIZE TABLE DØxL (mm)

Cap (μF)	Code	Working Voltage (Vdc)					
		160	200	250	350	400	450
2.2	2R2						10 x 14
3.3	3R3				10 x 14	10 x 14	10 x 18
4.7	4R7				10 x 18	10 x 18	10 x 22
							16 x 17
10	100	10 x 14	10 x 18	10 x 18	10 x 22	10 x 22	12.5 x 22
					12.5 x 17	16 x 17	18 x 17
22	220	10 x 22	10 x 22	12.5 x 22	12.5 x 22	16 x 22	18 x 22
			12.5 x 17	16 x 17	18 x 17		
33	330	10 x 22	12.5 x 22	12.5 x 22	16 x 22	18 x 22	
		12.5 x 17	16 x 17	18 x 17			
47	470	12.5 x 22	12.5 x 22	16 x 22	18 x 22		
		16 x 17	18 x 17				
68	680	16 x 22	16 x 22	18 x 22			
		18 x 17					
100	101	18 x 22	18 x 22				

See page 166 for complete case size details

MAXIMUM RIPPLE CURRENT (mA rms AT 120Hz AND 105°C)

Cap (μF)	Working Voltage (Vdc)					
	160	200	250	350	400	450
2.2						29
3.3				38	40	41
4.7				50	50	49
10	70	80	88	270	250	310
22	470	470	560	350	410	560
33	470	600	560	480	600	
47	600	600	710	670		
68	750	750	990			
100	1060	1060				

MAXIMUM E.S.R. (Ω AT 120Hz AND 20°C)

Cap (μF)	Working Voltage (Vdc)					
	160	200	250	350	400	450
2.2						181
3.3				101	121	121
4.7				70.7	84.8	84.8
10	24.9	24.9	24.9	33.2	39.9	39.9
22	11.3	11.3	11.3	15.1	18.1	18.1
33	7.55	7.55	7.55	10.1	12.1	
47	5.30	5.30	5.30	7.07		
68	3.66	3.66	3.66			
100	2.49	2.49				



FEATURES

- EXTENDED TEMPERATURE **+125°C**
- CYLINDRICAL LEADLESS TYPE FOR SURFACE MOUNTING
- WIDE TEMPERATURE RANGE AND HIGH RIPPLE CURRENT
- DESIGNED FOR AUTOMATIC MOUNTING AND REFLOW SOLDERING

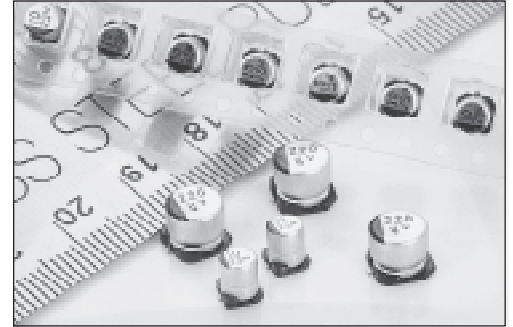

CHARACTERISTICS

Rated Voltage Range	6.3 ~ 50 Vdc						
Rated Capacitance Range	33 ~ 1500 μ F						
Operating Temperature Range	-40° ~ +125°C						
Capacitance Tolerance	\pm 20%(M), \pm 10%(K)*						
Max. Leakage Current After 2 Minutes at 20°C	0.01CV or 3 μ A, whichever is greater						
Surge Voltage & Max. Tan δ	W.V. (Vdc)	6.3	10	16	25	35	50
	S.V. (Vdc)	8.0	13	20	32	44	63
	Tand @ 120Hz/20°C	0.30	0.24	0.20	0.16	0.14	0.14
Low Temperature Stability (Impedance Ratio @ 120Hz)	W.V. (Vdc)	6.3	10	16	25	35	50
	Z-25°C/Z +20°C	4	3	2	2	2	2
	Z-40°C/Z +20°C	10	8	6	4	4	4
Load Life Test at Rated W.V. 125°C 1,000 Hours	Capacitance Change	Within +25% of initial measured value					
	Tan δ	Less than 200% of specified value					
	Leakage Current	Less than specified value					

*Optional \pm 10% (K) Tolerance available on most values. Contact factory for availability.

MAXIMUM PERMISSIBLE RIPPLE CURRENT (mA rms AT 120Hz AND 125°C)

Cap (μ F)	Working Voltage					
	6.3	10	16	25	35	50
33						100
47					110	105
100				110	190	160
150					250	220
220			120	200	260	
330		120	200	270		
470	140	210	290			
680	210	300	300			
1000	330	320				
1500	350					

MAXIMUM E.S.R. (Ω AT 20°C AND 120Hz)

Cap (μ F)	Working Voltage (Vdc)					
	6.3	10	16	25	35	50
33						7.05
47					4.95	4.95
100				2.65	2.32	2.32
150					1.55	1.55
220			1.51	1.21	1.06	
330		1.21	1.01	0.81		
470	1.06	0.85	0.71			
680	0.73	0.59	0.49			
1000	0.50	0.40				
1500	0.33					

STANDARD PRODUCTION SIZE D ϕ xL (mm)

Cap (μ F)	Code	Working Voltage (Vdc)					
		6.3	10	16	25	35	50
33	330						8x10.5
47	470					8x10.5	10x10.5
100	101				8x10.5	10x10.5	12.5x14
150	151					12.5x14	12.5x14
220	221			8x10.5	10x10.5	12.5x14	
330	331		8x10.5	10x10.5	12.5x14		
470	471	8x10.5	10x10.5	12.5x14			
680	681	10x10.	12.5x14	12.5x14			
1000	102	12.5x14	12.5x14				
1500	152	12.5x14					

See page 164 for complete case size details

RIPPLE CURRENT CORRECTION FACTOR

Frequency (Hz)	100 \leq f <1K	1K \leq f <10K	10K \leq f <100K	100K \leq f
C \leq 33 μ F	1.0	1.2	1.3	1.45
33 μ F < C	1.0	1.1	1.2	1.3

PART NUMBERING SYSTEM

NACT 101 M 25V 8X10.5 TR 13

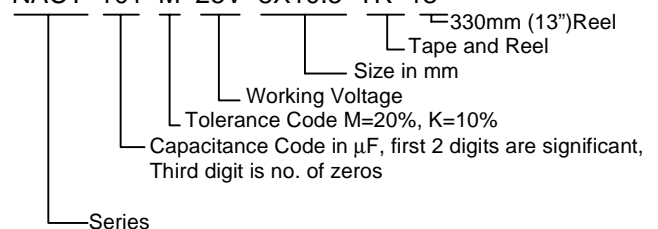

FEATURES

- CYLINDRICAL LEADLESS TYPE FOR SURFACE MOUNTING
- VERY LOW IMPEDANCE AT 100KHz
- WIDE TEMPERATURE RANGE (-55 +105°C)
- MAXIMUM 5.5mm HEIGHT
- ANTI-SOLVENT (2 MINUTES)
- DESIGNED FOR AUTOMATIC MOUNTING AND REFLOW SOLDERING



SURFACE MOUNT

CHARACTERISTICS

Rated Voltage Range	6.3 ~ 50 Vdc						
Rated Capacitance Range	0.47 ~ 150μF						
Operating Temperature Range	-55° ~ +105°C						
Capacitance Tolerance	±20%(M), ±10%(K)*						
Max. Leakage Current After 2 Minutes at 20°C	0.01CV or 3μA, whichever is greater						
Surge Voltage & Max. Tanδ	W.V. (Vdc)	6.3	10	16	25	35	50
	S.V. (Vdc)	8.0	13	20	32	44	63
	Tand @ 120Hz/20°C	0.24	0.20	0.16	0.14	0.12	0.10
Low Temperature Stability (Impedance Ratio at 120Hz)	W.V. (Vdc)	6.3	10	16	25	35	50
	Z-40°C/Z+20°C	3	2	2	2	2	2
	Z-55°C/Z+20°C	5	4	4	3	3	3
Load Life Test 105°C 1,000 Hours	Capacitance Change	Within + 25% of initial measured value					
	Tanδ	Less than 200% of specified value					
	Leakage Current	Less than specified value					

* Optional ± 10% (K) Tolerance available on most values. Contact factory for availability.

MAXIMUM PERMISSIBLE RIPPLE CURRENT (mA rms AT 100KHz AND 105°C)

Cap (μF)	Working Voltage (Vdc)						
	6.3	10	16	25	35	50	
0.47					45	30	
1.0					60	37	
2.2					60	45	
3.3					60	52	
4.7				60	60	75	
10			60	95	95	120	
22	60	95	95	140	140		
33	95	95	140	140			
47	95	140	140				
100	140	140	140				
150	140						

MAXIMUM IMPEDANCE (Ω AT 20°C AND 100KHz)

Cap (μF)	Working Voltage (Vdc)						
	6.3	10	16	25	35	50	
0.47					6.5	8.0	
1.0					3.6	7.4	
2.2					3.6	6.6	
3.3					3.6	5.4	
4.7					3.6	3.6	2.9
10				3.6	1.5	1.5	1.3
22	3.6	1.5	1.5	1.5	0.8	0.8	
33	1.5	1.5	0.8	0.8			
47	1.5	0.8	0.8				
100	0.8	0.8	0.8				
150	0.7						

STANDARD PRODUCTION SIZE DØ xL (mm)

Cap (μF)	Code	Working Voltage (Vdc)						
		6.3	10	16	25	35	50	
0.47	R47					4x5.5	4x5.5	
1.0	1R0					4x5.5	4x5.5	
2.2	2R2					4x5.5	4x5.5	
3.3	3R3					4x5.5	4x5.5	
4.7	4R7				4x5.5	4x5.5	5x5.5	
10	100			4x5.5	5x5.5	5x5.5	6.3x5.5	
22	220	4x5.5	5x5.5	5x5.5	6.3x5.5	6.3x5.5		
33	330	5x5.5	5x5.5	6.3x5.5	6.3x5.5			
47	470	5x5.5	6.3x5.5	6.3x5.5				
100	101	6.3x5.5	6.3x5.5	6.3x5.5				
150	151	6.3x5.5						

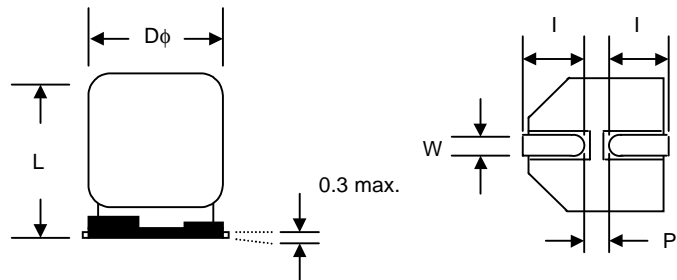

PART NUMBERING SYSTEM

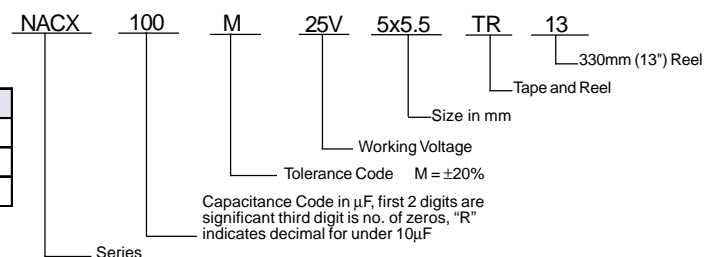

FEATURES

- CYLINDRICAL LEADLESS TYPE FOR SURFACE MOUNTING
- VERY LOW IMPEDANCE & HIGH RIPPLE CURRENT AT 100K Hz
- SUITABLE FOR DC-DC CONVERTER, DC-AC INVERTER, ETC.
- NEW EXPANDED CV RANGE, UP TO 3300 μ F
- ANTI-SOLVENT (2 MINUTES)
- DESIGNED FOR AUTOMATIC MOUNTING AND REFLOW SOLDERING



CHARACTERISTICS

Rated Voltage Range	6.3 ~ 50 Vdc							
Rated Capacitance Range	4.7 ~ 3300 μ F							
Operating Temp. Range	-55 ~ +105°C							
Capacitance Tolerance	\pm 20%(M), \pm 10%(K)*							
Max. Leakage Current After 2 Minutes @ 20°C	0.01CV or 0.3 μ A, whichever is greater							
Tan δ @ 120Hz/20°C	W.V. (Vdc)	6.3	10	16	25	35	50	
	4 ~ 6mm Dia.	0.24	0.20	0.16	0.14	0.12	0.10	
	8mm Dia ~ up	C \leq 1000 μ F	0.28	0.24	0.20	0.16	0.14	0.12
		C = 1500 μ F	0.29	0.25	0.21	-	-	-
		C = 2200 μ F	0.30	0.26	-	-	-	-
Low Temperature Stability Impedance Ratio @ 120Hz	W.V. (Vdc)	6.3	10	16	25	35	50	
	Z-40°C/Z +20°C	3	2	2	2	2	2	
	Z-55°C/Z +20°C	5	4	4	3	3	3	
Load Life Test 105°C 1,000 Hours	Capacitance Change	Within \pm 25% of initial measured value						
	Tan δ	Less than 200% of specified max. value						
	Leakage Current	Less than specified max. value						

**LOW IMPEDANCE
AT HIGH FREQUENCY.**
INDUSTRY STANDARD
STYLE FOR SWITCHERS
AND CONVERTERS

* Optional \pm 10% (K) Tolerance available on most values. Contact factory for availability.

MAXIMUM PERMISSIBLE RIPPLE CURRENT (mA rms AT 100KHz AND 105°C)

Cap (μ F)	Working Voltage (Vdc)					
	6.3	10	16	25	35	50
4.7	-	-	-	-	80	-
10	-	-	-	80	150	165
15	-	-	80	150	150	-
22	-	80	150	150	150	165
27	80	-	-	-	-	-
33	-	150	-	230	230	185
47	150	-	230	230	230	185
56	150	-	-	230	-	-
68	-	230	230	230	280	300
100	230	-	230	280	-	300
120	-	230	-	-	-	-
150	230	-	280	450	450	670
220	230	280	280	450	450	670
330	280	450	450	450	670	-
470	450	450	450	670	-	-
680	450	-	670	-	900	-
1000	450	670	-	900	-	-
1500	670	-	900	-	-	-
2200	-	900	-	-	-	-
3300	900	-	-	-	-	-

MAXIMUM IMPEDANCE (Ω AT 20°C AND 100KHz)

Cap (μ F)	Working Voltage (Vdc)					
	6.3	10	16	25	35	50
4.7	-	-	-	-	1.80	-
10	-	-	-	1.80	0.76	0.88
15	-	-	1.80	0.76	0.76	-
22	-	1.80	0.76	0.76	0.76	0.88
27	1.80	-	-	-	-	-
33	-	0.76	-	0.44	0.44	0.75
47	0.76	-	0.44	0.44	0.44	0.75
56	0.76	-	-	0.44	-	-
68	-	0.44	0.44	0.44	0.34	0.40
100	0.44	-	0.44	0.34	-	0.40
120	-	0.44	-	-	-	-
150	0.44	-	0.34	0.17	0.17	0.22
220	0.44	0.34	0.34	0.17	0.17	0.22
330	0.34	0.17	0.17	0.17	0.09	-
470	0.17	0.17	0.17	0.09	-	-
680	0.17	-	0.09	-	0.066	-
1000	0.17	0.09	-	0.066	-	-
1500	0.09	-	0.066	-	-	-
2200	-	0.066	-	-	-	-
3300	0.066	-	-	-	-	-



STANDARD PRODUCT AND CASE SIZE TABLE DØ x L (mm)

Cap (µF)	Code	Working Voltage (Vdc)					
		6.3	10	16	25	35	50
4.7	4R7	-	-	-	-	4x6.3	-
10	100	-	-	-	4x6.3	5x6.3	6.3x6.3
15	150	-	-	4x6.3	5x6.3	5x6.3	-
22	220	-	4x6.3	5x6.3	5x6.3	5x6.3	6.3x6.3
27	270	4x6.3	-	-	-	-	-
33	330	-	5x6.3	-	6.3x6.3	6.3x6.3	6.3x8
47	470	5x6.3	-	6.3x6.3	6.3x6.3	6.3x6.3	6.3x8
56	560	5x6.3	-	-	6.3x6.3	-	-
68	680	-	6.3x6.3	6.3x6.3	6.3x6.3	6.3x8	8x10.5
100	101	6.3x6.3	-	6.3x6.3	6.3x8	-	8x10.5
120	121	-	6.3x6.3	-	-	-	-
150	151	6.3x6.3	-	6.3x8	8x10.5	8x10.5 10x8*	10x10.5
220	221	6.3x6.3	6.3x8	6.3x8	8x10.5 10x8*	8x10.5	10x10.5
330	331	6.3x8	8x10.5	8x10.5 10x8*	8x10.5	10x10.5	-
470	471	8x10.5	8x10.5 10x8*	8x10.5	10x10.5	-	-
680	681	10x8*	-	10x10.5	-	12.5x14	-
1000	102	8x10.5	10x10.5	-	12.5x14	-	-
1500	152	10x10.5	-	12.5x14	-	-	-
2200	222	-	12.5x14	-	-	-	-
3300	332	12.5x14	-	-	-	-	-



SURFACE MOUNT

*Optional Sizes

DIMENSIONS (mm) and STANDARD REEL QUANTITIES

Case Size	DØ ± 0.5	L max.	A ± 0.2	B ± 0.2	I ± 0.2	W	P ± 0.2	Q'ty per Reel
4x6.3	4.0	6.3	4.3	4.3	1.8	0.5-0.8	1.0	1,200 pcs
5x6.3	5.0	6.3	5.3	5.3	2.1	0.5-0.8	1.4	800 pcs
6.3x6.3	6.3	6.3	6.6	6.6	2.5	0.5-0.8	2.2	800 pcs
6.3x8	6.3	8.0	6.6	6.6	2.5	0.5-0.8	2.2	500 pcs
8x10.5	8.0	10.5	8.3	8.3	2.9	0.7-1.0	3.2	300 pcs
10x8	10.0	8.0	10.3	10.3	3.2	0.7-1.0	4.6	300 pcs
10x10.5	10.0	10.5	10.3	10.3	3.2	0.7-1.0	4.6	300 pcs
12.5x14	12.5	14.0	12.8	12.8	4.5	0.7-1.0	4.6	200 pcs

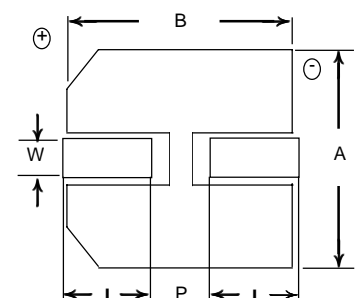
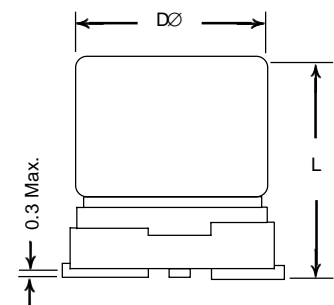

PART NUMBERING SYSTEM

NACZ 101 M 16V 6.3X6.3 TR 13

- Series
- Capacitance Code in µF, first 2 digits are significant, Third digit is no. of zeros, "R" indicates decimal for For under 10µF
- Tolerance Code M=20%, K=10%
- Working Voltage
- Size in mm
- Tape and Reel
- ≡ 330mm (13") Reel



Surface Mount Aluminum Electrolytic Capacitors

NACZF Series

FEATURES

- CYLINDRICAL LEADLESS TYPE FOR SURFACE MOUNTING
- HIGH CAPACITANCE VALUES (UP TO 6800 μ F)
- LOW IMPEDANCE & HIGH RIPPLE CURRENT AT 100KZ
- 12.5mm x 17mm ~ 18mm x 22mm Size
- 4 TERMINALS (16 & 18mm Dia.) FOR HIGH VIBRATION STABILITY
- LONG LIFE (5000 HOURS AT +105°C)
- COMPATIBLE WITH REFLOW SOLDERING



CHARACTERISTICS

Rated Voltage Range		6.3 ~ 100 Vdc							
Rated Capacitance Range		47 ~ 6800 μ F							
Operating Temperature Range		- 40°C ~ + 105°C							
Capacitance Tolerance		± 20% (M)							
Max. Leakage Current After 2 Minutes		0.06CV + 10 μ F							
Max. Tan δ at 120Hz & 20°C		6.3Vdc	10Vdc	16Vdc	25Vdc	35Vdc	50Vdc	63Vdc	100Vdc
		0.22	0.19	0.15	0.14	0.12	0.20	0.08	0.24
Low Temperature Stability (Impedance Ratio @ 120Hz)	Z -25°C/Z +20°C	2	2	2	2	2	2	2	2
	Z -40°C/Z +20°C	3	3	3	3	3	3	3	3
	Z -55°C/Z +20°C	4	4	4	4	4	4	4	4
High Temperature Load Life 5000 Hours at +105°C Rated WVDC	Capacitance Change	Within ± 20% of initial measured value							
	Tan δ	Less than 200% of specified value							
	Leakage Current	Less than the specified maximum value							
Resistance to Soldering Heat Within the Recommended Reflow Conditions	Capacitance Change	Within ± 10% of initial measured value							
	Tan δ	Less than the specified maximum value							
	Leakage Current	Less than the specified maximum value							

STANDARD PRODUCT AND CASE SIZE TABLE D \times L (mm)

Cap (μ F)	Code	Working Voltage (Vdc)							
		6.3	10	16	25	35	50	63	100
47	470								12.5x17
68	680							12.5x17	12.5x17
100	101							12.5x17	16x17
220	221						12.5x17	16x17	18x17
330	331					12.5x17	16x17	18x17	18x22
470	471				12.5x17	16x17	18x17	18x22	
1000	102		12.5x17	16x17	18x17	18x17	18x22		
2200	222	16x17	16x17	18x17	18x22	18x22			
3300	332	18x17	18x17	18x22					
4700	472	16x22	18x22						
6800	682	18x22	18x22						

See page 166 for complete size details.

MAXIMUM RIPPLE CURRENT (mA rms AT 100Khz AND 105°C)

Cap (μ F)	Working Voltage (Vdc)							
	6.3	10	16	25	35	50	63	100
47								511
100							1020	511
220						1150	1410	917
330					1205	1610	1690	1230
470				1205	1690	1900	2290	
1000		1205	1690	2000	2000	2420		
2200	1690	1690	2000	2490	2490			
3300	2000	2000	2490					
4700	2205	2490						
6800	2490	2490						

MAXIMUM IMPEDANCE (Ω AT 100Khz AND 20°C)

Cap (μ F)	Working Voltage (Vdc)							
	6.3	10	16	25	35	50	63	100
47								0.150
68							0.150	0.150
100							0.150	0.090
220						0.110	0.090	0.086
330					0.065	0.080	0.086	0.055
470				0.065	0.043	0.068		
1000		0.065	0.043	0.038	0.038	0.042		
2200	0.043	0.043	0.038	0.028	0.028			
3300	0.038	0.038	0.028					
4700	0.029	0.028						
6800	0.028	0.028						



Surface Mount Aluminum Electrolytic Capacitors NACEN Series

FEATURES

- CYLINDRICAL LEADLESS TYPE FOR SURFACE MOUNTING
- NON-POLARIZED, 1000 HOURS AT 85°C
- 5.5mm HEIGHT
- ANTI-SOLVENT (2 MINUTES)
- DESIGNED FOR AUTOMATIC MOUNTING AND REFLOW SOLDERING



SURFACE MOUNT

CHARACTERISTICS

Rated Voltage Range	6.3 ~ 50 Vdc						
Rated Capacitance Range	0.1 ~ 47μF						
Operating Temperature Range	-40° ~ +85°C*						
Capacitance Tolerance	±20%(M)						
Max. Leakage Current After 2 Minutes @ 20°C	0.05CV or 10μA, whichever is greater						
Max. Tanδ @ 120 Hz/20°C	W.V. (Vdc)	6.3	10	16	25	35	50
	Tan δ @ 120Hz/20°C	0.24	0.20	0.17	0.17	0.15	0.15
Low Temperature Stability	W.V. (Vdc)	6.3	10	16	25	35	50
	Z-25°C/Z +20°C	4	3	2	2	2	2
Impedance Ratio @ 120Hz	Z-40°C/Z +20°C	8	6	4	4	3	3
	Capacitance Change	Within ±25% of initial measured value					
Load Life Test 85°C, 1,000 Hours (Reverse polarity every 250 hours)	Tanδ	Less than 200% of specified value					
	Leakage Current	Less than specified value					

* -EXTENDED TEMPERATURE VERSIONS, TO +105°C, ARE AVAILABLE BY SPECIAL ORDER. PLEASE CONTACT NIC FOR DETAILS.

MAXIMUM PERMISSIBLE RIPPLE CURRENT (mA rms AT 120Hz AND 85°C)

W.V. (Vdc)	6.3	10	16	25	35	50
0.1						1.0
0.22						2.0
0.33						2.8
0.47						4.0
1.0						8.4
2.2					8.4	13
3.3				12	16	17
4.7			12	16	18	20
10		17	23	27	29	23
22	28	33	37			
33	37	41	49			
47	45					

STANDARD PRODUCT AND CASE SIZE TABLE DXL (mm)

Cap (μF)	Code	W.V. (Vdc)					
		6.3	10	16	25	35	50
0.1	R10						4x5.5
0.22	R22						4x5.5
0.33	R33						4x5.5
0.47	R47						4x5.5
1.0	1R0						4x5.5
2.2	2R2					4x5.5	5x5.5
3.3	3R3				4x5.5	5x5.5	5x5.5
4.7	4R7			4x5.5	5x5.5	5x5.5	6.3x5.5
10	100		4x5.5	5x5.5	6.3x5.5	6.3x5.5	6.3x5.5
22	220	5x5.5	6.3x5.5	6.3x5.5			
33	330	6.3x5.5	6.3x5.5	6.3x5.5			
47	470	6.3x5.5					

DIMENSIONS (mm) AND STANDARD REEL QUANTITIES

Case Size	DØ ± 0.5	L max.	A ± 0.2	B ± 0.2	I ± 0.2	W	P ± 0.2
4x5.5	4.0	5.5	4.3	4.3	1.8	0.5-0.8	1.0
5x5.5	5.0	5.5	5.3	5.3	2.1	0.5-0.8	1.4
6.3x5.5	6.3	5.5	6.6	6.6	2.5	0.5-0.8	2.2

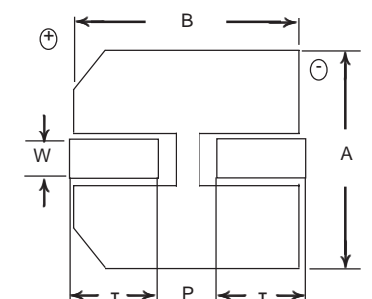
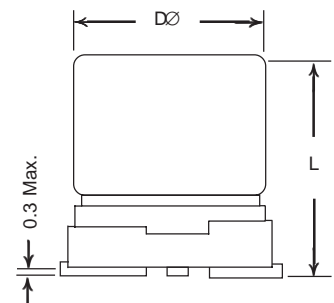

PART NUMBERING SYSTEM

