

PRODUCT GUIDE

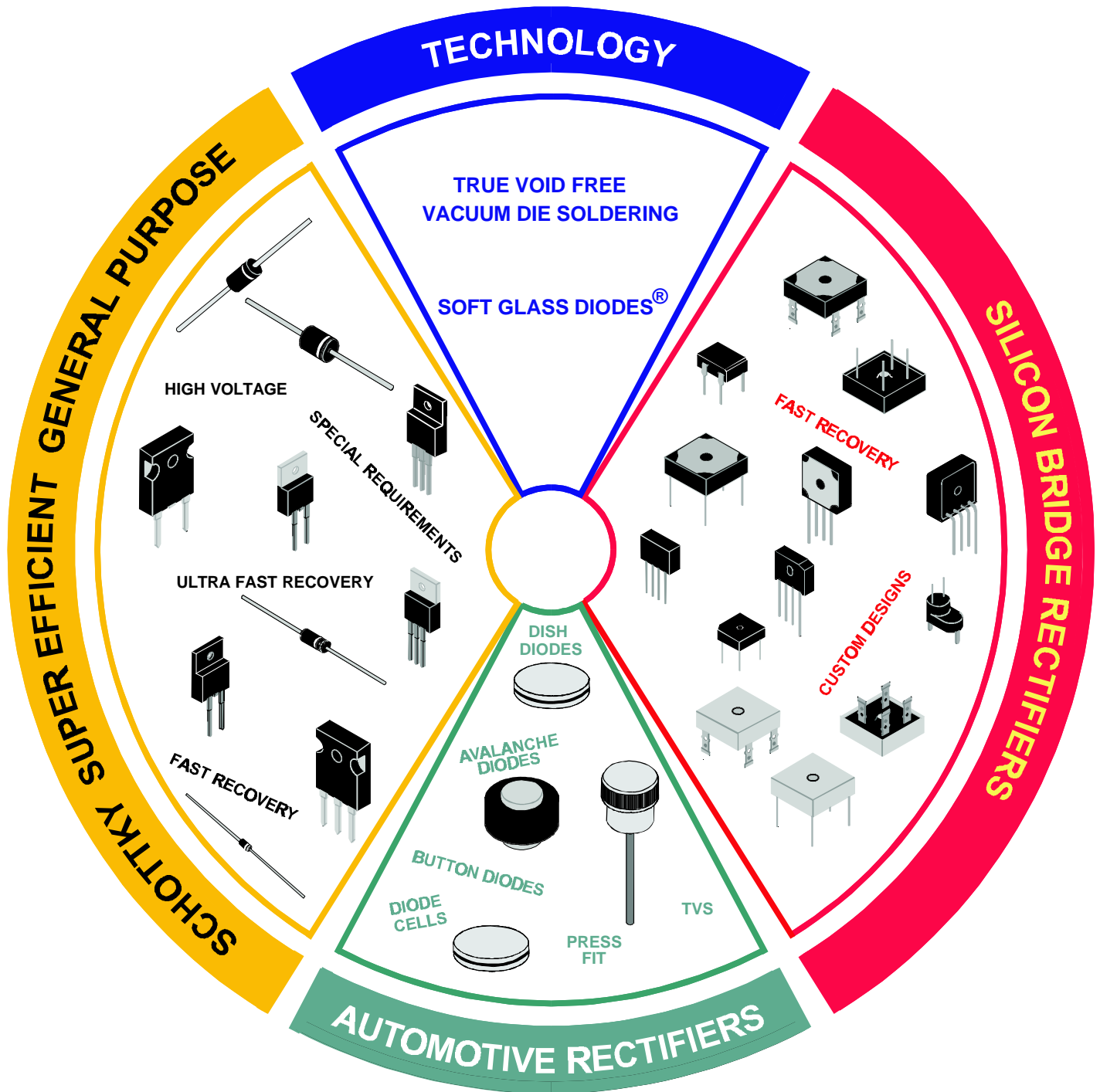

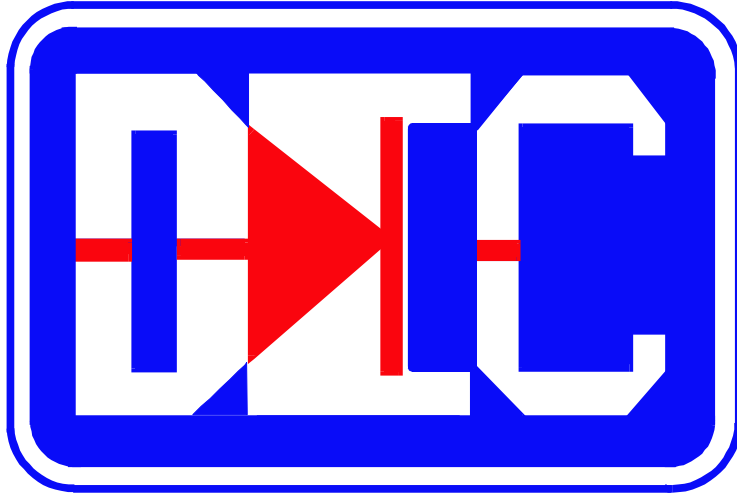

DIOTEC ELECTRONICS CORP.

THE RECTIFIER SPECIALISTS

**THE ONLY QUALITY
DIODES AND RECTIFIERS
AT COMPETITIVE PRICES**

18020 HOBART BLVD, UNIT B • GARDENA, CALIFORNIA 90248 USA

TEL: 310 - 767 - 1052 • FAX: 310 - 767 - 7958

EMAIL: support@diotec-usa.com • WEB SITE: www.diotec-usa.com



DIOTEC ELECTRONICS CORPORATION

18020 HOBART BLVD.

GARDENA, CA 90248 USA

PH: 310-767-1052 FX: 310-767-7958 E-MAIL: support@diotec-usa.com WEB SITE: www.diotec-usa.com

EVER WONDER WHY SOME DIODES DIE PREMATURELY WITHOUT OBVIOUS CAUSE

Most Likely It's The Invisible Killer **DIE ATTACH SOLDER VOIDS**

This invisible problem is much, much, more serious, and a lot more common than you might think. In the photographs below, diodes produced by a prestigious multinational semiconductor manufacturer were examined for die solder quality. These diodes were provided by one of our potential customers who have experienced serious quality problems and premature failures.

This set of photos illustrates a very common situation when a diode is pried open

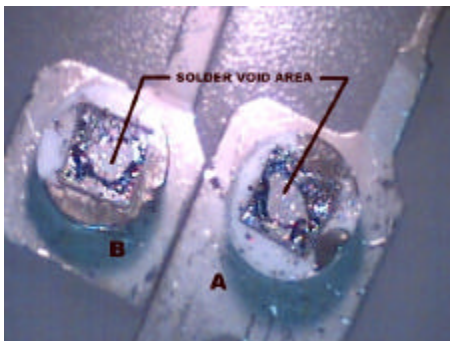

LARGE VOID AREA REVEALED IN THE SOLDER LAYER

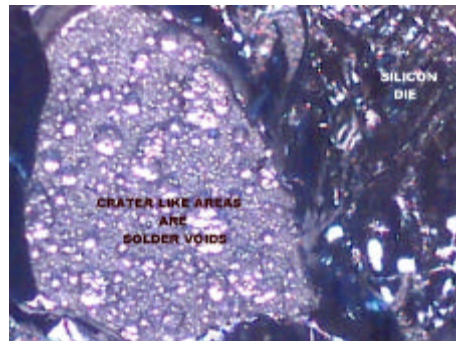

SECTION B

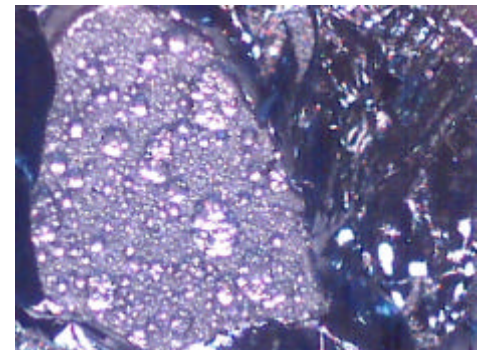

SECTION A

NUMEROUS SOLDER VOIDS CAN CLEARLY BE SEEN IN THESE CLOSE UPS. These Voids 1) Greatly Weaken The Diode's Mechanical Integrity, 2) Increase The Forward Voltage Drop, and 3) **Severely Restrict The Dissipation of Heat From The Die.** Restricted Heat Dissipation causes the Diode to Operate at Elevated Temperatures Which Could Lower Its Current Handling and/or Cause Premature Failure.

This set of photographs illustrates another common, but much more serious, situation. Here the diode is pried open and separates completely at the die solder layer

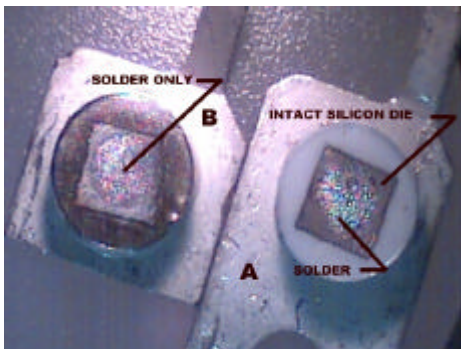

**ONLY SOLDER IN SECTION B
CHIP IS INTACT IN SECTION A
SOLDER COVERS ~ 50% OF DIE**

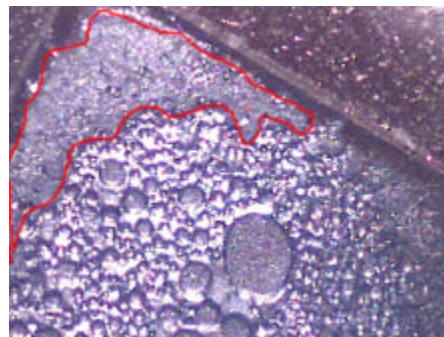

SECTION B - ONLY SOLDER

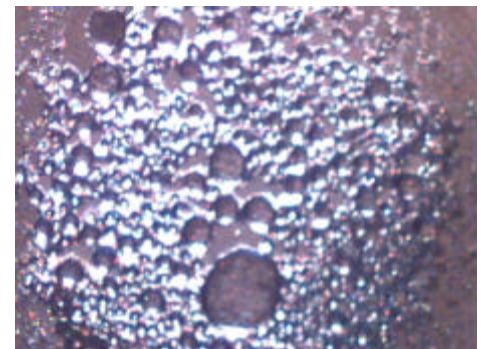

SECTION A - DIE SIDE

The Solder Either Failed to Wet And, Hence, Bond to The Die's Surface (Surface Outlined in Red on Section B) or is riddled with voids. As a Result, This Diode Has Absolutely No Mechanical Strength And May Fail On Impact if dropped or Struck. Additionally, The Thermal Resistance of This Diode is so High that Thermal Runaway is a Certainty.

See The **DIOTEC Difference - VOID FREE DIE SOLDERING.**

DIOTEC ELECTRONICS CORPORATION

This is the DIOTEC difference.



**BREAKS AT SILICON DIE
NO VISIBLE VOIDS.**

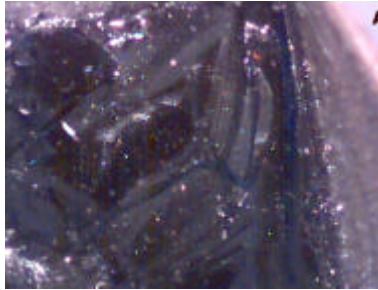

SECTION A

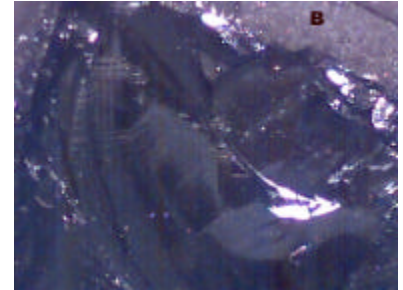

SECTION B

Superior Soldering Results in SUPERIOR MECHANICAL STRENGTH, SUPERB HEAT DISSIPATION, and LOWER FORWARD VOLTAGE DROP

DIOTEC utilizes an advanced, computer controlled, vacuum die soldering process, which enables silicon chips to be soldered to metal with **exceptional consistency** and **void free quality**. Thus, DIOTEC diodes and bridge rectifiers have unmatched heat dissipation, cooler junction temperatures, lower leakage currents, and reduced thermal stress. Additionally, the high quality die attachment allows the diodes survive mechanical shock without bond failure, another common problem with most offshore "cheap" diodes.

SHOULD YOU WANT:

- **Want to discuss this topic further?**
- **A free analysis similar to that shown here to determine the quality of the diodes you are now using? We'll tell it like we see it and return your items with the pictures so you can see for yourself.**
- **Wish to put us to the test in your environment? Request product samples**

Please don't hesitate to contact:

JOE LIN or DEAN LIGOCKI

PH: 310-767-1052

FX: 310-767-7958

joel@diotec-usa.com

deanl@diotec-usa.com

**DIOTEC ELECTRONICS CORPORATION
THE ONLY HIGH QUALITY DIODES & RECTIFIERS AT COMPETITIVE PRICES**

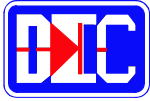

DIOTEC ELECTRONICS CORP.
18020 Hobart Blvd., Unit B
Gardena, CA 90248 U.S.A
Tel.: (310) 767-1052 Fax: (310) 767-7958

INTRODUCTION

DIOTEC Electronics Corp. is a major manufacturer of power diodes and rectifiers, with facilities and representatives worldwide. Principle engineering, sales, technical, and administrative personnel are located at DIOTEC's headquarters in Gardena, California, 20 miles south of the Los Angeles International airport. Major laboratory, test, and manufacturing facilities are located in Penang, Malaysia, and Carson, California USA.

DIOTEC was established to fill a severe industry need for a reliable and dependable manufacturer who:

- ▶ Could offer comprehensive, high quality diode/rectifier product lines at very competitive prices
- ▶ Is capable, flexible, and willing to provide prompt technical and professional assistance to its customers
- ▶ Has an adequate inventory near its customers to support their production requirements at all times.

In its 15 year history, DIOTEC and its affiliate company have grown from a star-up company to one with over \$12 million in worldwide sales. Initially, DIOTEC's product line was limited to general purpose axial lead silicon diodes. Today, DIOTEC offers Schottky Barrier diodes, Super Efficient and Ultra-Fast Recovery diodes, a significantly expanded line of General Purpose and Fast Recovery diodes, and the most comprehensive line of Full Wave Bridge Rectifiers.

DIOTEC provides its customers with diodes and rectifiers of superior quality at competitive prices. This superior quality results from using advanced, computer controlled, vacuum die soldering process which enables silicon chips to be soldered to metal with exceptional consistency and void free quality. Thus, DIOTEC diodes and bridge rectifiers have unmatched heat dissipation, cooler junction temperature, lower leakage currents, and reduced thermal stress.

Additionally, the high quality die attachment allows the diodes to survive mechanical shock without bond failure, another common problem with most offshore "cheap" diodes.

DIOTEC has also introduced the industry's only "Soft Glass Diode". These diodes exhibit unmatched mechanical and thermal resistance properties. Additional information on "Soft Glass" may be found in Appendix IX.

DIOTEC has 7 main product lines:

- Automotive Diodes (TVS & Standard - 12 to 75 amp)*
- Full Wave Bridge Rectifiers (1 to 50 amp, 50 - 1000 Volt)*
- Super Efficient and Ultra-Fast Recovery Diodes Fast Recovery Diodes*
- Schottky Barrier Rectifiers*
- Fast Recovery Full Wave Bridge Rectifiers*
- General Purpose Diodes*
- High Voltage Diodes*

VISIT US ON THE WEB for the latest product and specification updates

DIOTEC's web site is located at: www.diotec-usa.com

Our general e-mail address is: support@diotec-usa.com

Take some time every once in a while to visit our web site. Our product lines/specifications are continually being reviewed and updated based on customer requirements, product design improvements, and quality testing. When considering one of our products for a specific application, always check the web site to ensure you have the latest specifications.

When USING THIS CATALOG, please keep in mind that every effort has been made to ensure that the information contained here is current, accurate, and of the necessary detail to support the component or design engineer. It is recognized that a standard product can not satisfy every application requirement. If your requirements fall in this category, do not hesitate to call, fax or e-mail our technical staff. We are here to help you!

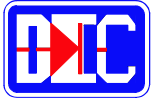

DIOTEC ELECTRONICS CORP.
18020 Hobart Blvd., Unit B
Gardena, CA 90248 U.S.A
Tel.: (310) 767-1052 Fax: (310) 767-7958

INTRODUCTION (Cont'd)

DIOTEC is dedicated to furnishing the highest quality products at the most competitive cost. Thus, product changes to improve reliability, function, and design may be made without notice. The information in this data book has been carefully reviewed and is believed to be accurate. However, no responsibility is assumed for inaccuracies. Before committing to a design, it is recommended that the designer request product samples (See Appendix IX) to validate the operational characteristics and performance in the actual application.

DIOTEC does not imply any warranty, or assume any liability from the application or use of any product or circuit described in this catalog. DIOTEC does not recommend the use of its products in applications where a failure/malfunction of the product may directly threaten life or injury. The user of DIOTEC's products in life support application assumes all risks of such use and indemnifies DIOTEC against all damages.

Following this introduction and table of contents, selector guides are provided for DIOTEC's Schottky Rectifiers, Super Efficient/Ultra Fast Diode, Bridge Rectifier, General Purpose Diode, and Fast Recovery Diode product lines. Industry cross-references are provided in the appendices to assist in the selection of the proper DIOTEC product for your application.

DATA BOOK CONTENTS

GENERAL

EVER WONDER WHY	3-4
INTRODUCTION	5-6
CONTENTS	7
SCHOTTKY RECTIFIER QUICK SELECTION GUIDE.....	8
SUPER EFFICIENT and ULTRA FAST RECOVERY DIODE QUICK SELECTION GUIDE	9
FULL WAVE BRIDGE RECTIFIER QUICK SELECTION GUIDE	10-11
FAST RECOVERY BRIDGE RECTIFIER SELECTION GUIDE	12
GENERAL PURPOSE DIODE QUICK SELECTION GUIDE	13
FAST RECOVERY DIODE QUICK SELECTION GUIDE	14

SCHOTTKY RECTIFIERS

Single Chip (1 to 30 Amp)	15-33 (Section A)
Center-Tap Dual Chip (12 to 60 Amp)	34-46 (Section B)

SUPER EFFICIENT and ULTRA FAST RECOVERY DIODES

Single Chip (1 to 15 Amp)	47-73 (Section C)
Center-Tap Dual Chip (6 to 30 Amp)	74-84 (Section D)

FULL WAVE BRIDGE RECTIFIERS

85-138 (Section E & F)

FAST RECOVERY FULL WAVE BRIDGE RECTIFIERS

139-148 (Section G)

GENERAL PURPOSE and FAST RECOVERY DIODES.....

149-184 (Section H)

HIGH VOLTAGE DIODES

185-189 (Section I)

AUTOMOTIVE DIODES

Transient Voltage Suppressors	190-202 (Section J)
Standard Diodes	203-217 (Section K)

APPENDICES

Appendix I Packaging Information	219
Appendix II Schottky Barrier Rectifier Cross Reference	220
Appendix III Super Efficient And Ultra Fast Recovery Diode Cross Reference	221-222
Appendix IV Standard And Fast Recovery Bridge Rectifier Cross Reference	223-225
Appendix V General Purpose And Fast Recovery Diode Cross Reference	226-227
Appendix VI Acronyms And Abbreviations	228
Appendix VII Alpha-Numeric Product List	229
Appendix VIII Sample Request Form	230-231
Appendix IX Soft Glass	232

SCHOTTKY RECTIFIER QUICK SELECTION GUIDE - SEE SECTIONS A and B

DIOTEC Schottky Barrier Rectifiers feature a metal semiconductor junction with guard ring, epitaxial construction, low forward voltage drop, high current capability, and molded plastic material with an U/L 94V-O flammability rating. These products are ideal for use in low voltage, high frequency power supplies, as very fast clamping diodes, free wheeling, and polarity protection applications. These devices feature switching times of less than 10nS and are offered in current ranges up to 60 Amperes and reverse voltages to 100 volts.

VRRM	I _o , AVERAGE RECTIFIED FORWARD CURRENT (AMPERES)															
	1		3		5	6	12		16		24	30		40	60	
	DO-41		DO-27		DO-27	TO-220AC (Fullyinsulated)	TO-220AC (Fullyinsulated)	TO-220AB (Fullyinsulated)	TO-247AC TO-3P	TO-220AB (Fullyinsulated)	TO-247AB TO-3P	TO-247AC TO-3P	TO-247AB TO-3P	TO-247AB TO-3P	TO-247AB TO-3P	TO-247AB TO-3P
20	1N5817	SK102	1N5820	SK302	SK502											
30	1N5818		1N5821										30SK30			SK6030C
40	1N5819	SK104	1N5822	SK304	SK504	6SK40	12SK40	SK1240C	16SK40	SK1640C	SK2440C	30SK40	SK3040C	SK4040C	SK6040C	
50						6SK50	12SK50	SK1250C	16SK50	SK1650C	SK2450C	30SK50	SK3050C	SK4050C	SK6050C	
60		SK106		SK306	SK506	6SK60	12SK60	SK1260C	16SK60	SK1660C	SK2460C	30SK60	SK3060C	SK4060C	SK6060C	
70		SK107		SK307	SK507	6SK70	12SK70	SK1270C	16SK70	SK1670C	SK2470C	30SK70	SK3070C	SK4070C	SK6070C	
80		SK108														
100		SK110		SK310	SK510	6SK100	12SK100	SK12100C	16SK100	SK16100C	SK24100C		SK30100C	SK40100C		
I _{FSM} (Amps)**	25	40	80	120	150	120	180	120	240	160	200	600	300	350	600	
T _c @ Rated I _o (°C)						100	100	100	100	110	100	100	90	85	90	
T _L @ Rated I _o (°C)	90	90	90	90	90											
T _J (Max) (°C)	125	150	125	150	150	150	150	150	150	150	150	150	150	150	150	
V _{FM} @ I _{FM} = I _o (T _x = 25 °C)***	0.6	0.8	0.525	0.8	0.85	0.85	0.85	0.85	0.85	0.85	0.85	0.7	0.85	0.92	0.65	

* I_o IS TOTAL DEVICE OUTPUT
 ** REPRESENTS THEM_{AX} FOR ALL PRODUCTS LISTED. SOME INDIVIDUAL DEVICES MAY EXHIBIT A LOWER I_{FSM}. DETAILED DATA SHEETS ARE AVAILABLE UPON REQUEST.
 *** T_x = T_L FOR DO-41/27 PACKAGED PRODUCTS; T_x = T_c FOR TO-220/247 PACKAGED PRODUCTS.

PART NUMBERING SYSTEM

(1) AXIAL LEAD PRODUCTS (SEE SECTION A)

Example: SK102 (1 Amp, 20 Volt, Axial Lead Schottky)

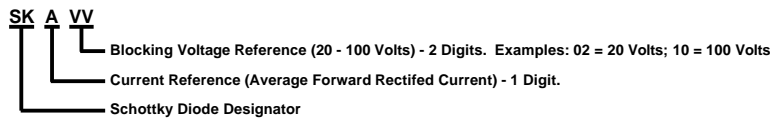

(2) TWO (2) PIN TO-220AC AND TO-247AC PACKAGED PRODUCTS (SEE SECTION A)

Examples: 6SK60 (6 Amp, 60 Volt, 2-Pin TO Packaged Schottky Diode)
 12SK100 (12 Amp, 100 Volt, 2-Pin TO Packaged Schottky Diode)

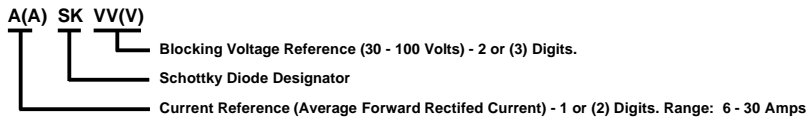

(3) THREE (3) PIN TO-220AB AND TO-247AB PACKAGED PRODUCTS (SEE SECTION B)

Example: SK1250C (12 Amp, 50 Volt, 3-Pin TO Packaged Schottky Diode)

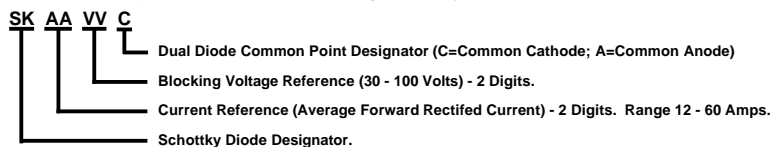

SUPER EFFICIENT/ULTRAFAST RECOVERY RECTIFIER

QUICK SELECTION GUIDE - SEE SECTIONS C and D

These products complement DIOTEC's Schottky product line by providing switching times in the 30 to 90 nS range. All TO-220/247 devices are supplied with the cathodes connected to the "backside" metal heatsink. Reverse polarity devices (i.e., common anode) may be available upon special request. Switching power supplies operating from 20 kHz to 250 kHz, inverters, and freewheeling diodes are excellent applications for these devices.

VRRM	Io, AVERAGE RECTIFIED FORWARD CURRENT (AMPERES)																											
	1		2	3		4	5		6		8		10	12	15	16		30										
	DO-41		DO-27																G-6A	TO-220AC	TO-220AB DualDiode*	TO-220AC	TO-220AC	TO-220AB DualDiode*	TO-220AC	TO-220AC	TO-220AB DualDiode*	TO-220AB DualDiode*
50	UFR100			SPR30	UFR300	UFR400			UFR600									SPR150										
100	UFR101	SPR11	SPR21	SPR31	UFR301	UFR401	SPR51	UFR601	6SPR01	SPR601C	8SPR01	SPR81	SPR1001C	12SPR01	SPR151	SPR1601C	SPR161C	UFR3001C										
200	UFR102	SPR12	SPR22	SPR32	UFR302	UFR402	SPR52	UFR602	6SPR02	SPR602C	8SPR02	SPR82	SPR1002C	12SPR02	SPR152	SPR1602C	SPR162C	UFR3002C										
300	UFR103	SPR13	SPR23	SPR33	UFR303	UFR403	SPR53	UFR603	6SPR03	SPR603C	8SPR03	SPR83	SPR1003C	12SPR03	SPR153	SPR1603C	SPR163C	UFR3003C										
400	UFR104	SPR14	SPR24	SPR34	UFR304	UFR404	SPR54	UFR604	6SPR04	SPR604C	8SPR04	SPR84	SPR1004C	12SPR04	SPR154	SPR1604C	SPR164C	UFR3004C										
500	UFR105				UFR305	UFR405		UFR605	6SPR05	SPR605C	8SPR05	SPR85	SPR1005C	12SPR05	SPR155	SPR1605C	SPR165C	UFR3005C										
600	UFR106		SPR26		UFR306	UFR406		UFR606							SPR156		SPR166C											
800	UFR108		SPR28		UFR308	UFR408		UFR608																				
1000	UFR110				UFR310	UFR410																						
IFSM (Amps)**	35	40	50,70	75	150	150	150	300	80	60	120	125	100	120	250	150	200	250										
Tc @ Rated Io (°C)									100	120	110	110	120	110	110	100	100	100										
TA @ Rated Io (°C)**	55	55	55	55	55	80,40,35	55	55																				
TJ (Max) (°C)	150	150	150	150	150	150	150	150	150	150	150	150	150	150	150	150	150	150										
TRR (nS)**	50,75	35	35,50,75	35	50,75	50,75	50	60,75,90	50,75	30	35,45	35,45	35,45	35,45	35,50	35,45	35,50	50,60										

* Io IS TOTAL DEVICE OUTPUT
 ** TWO OR MORE ENTRIES INDICATES A DIFFERENCE IN PARAMETER VALUES AMONG THE SPECIFIC PRODUCTS IN THE SERIES LISTED.

PART NUMBERING SYSTEM

AXIAL LEAD PRODUCTS (SEE SECTION C)

(a) Example: SPR21 (2 Amp, 100 Volt Axial Lead Super Efficient Rectifier)

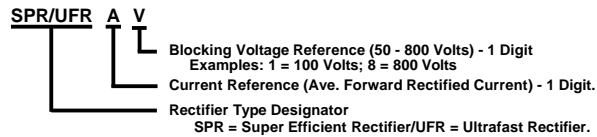

(b) Example: UFR302 (3 Amp, 200 Volt, Axial Lead, Ultrafast Rectifier)

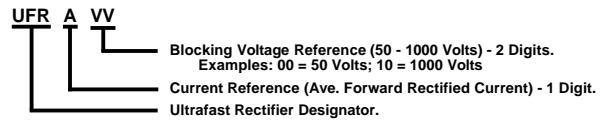

TWO (2) PIN TO-220AC PACKAGED PRODUCTS (SEE SECTION C)

(a) Example: 12SPR01 (12 Amp, 100 Volt, 2-Pin, FULLY INSULATED, Super Efficient Rectifier)

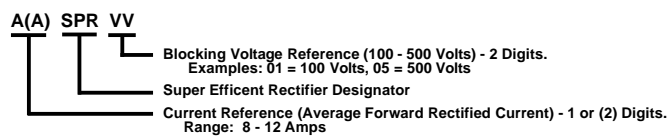

(b) Example: SPR85 (8 Amp, 500 Volt, 2-Pin, NON-INSULATED, Super Efficient Rectifier)

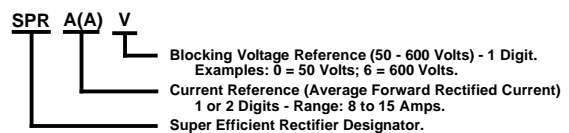

THREE (3) PIN TO-220AB AND TO-247AB PACKAGED PRODUCTS (SEE SECTION D)

(a) Example: SPR605C (6 Amp, 500 Volt, 3-Pin FULLY INSULATED Super Efficient Rectifier)

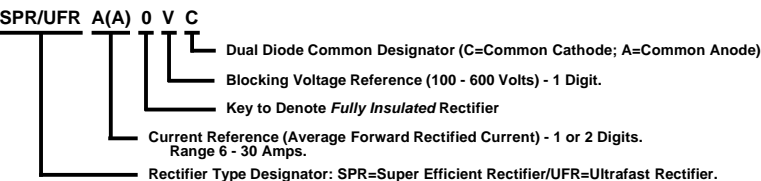

(b) Example: SPR163C (16 Amp, 300 Volt, 3-Pin NON-INSULATED Super Efficient Rectifier)

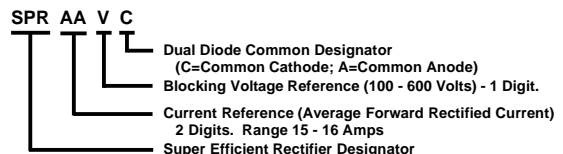

SILICON BRIDGE RECTIFIER QUICK SELECTION GUIDE - SEE SECTION E

DIOTEC offers a complete line of single phase full wave bridge rectifiers. A wide variety of package designs allows these bridges to be used in virtually any application. Forward current outputs range from 1 to 50 Amps with reverse voltages from 50 to 1000 Volts.

VRRM	Io, AVERAGE RECTIFIED FORWARD CURRENT (AMPERES) - Note 1																
	1	1.5	2	3	4	5	6	8	10								
50	DI100	S1NB05	WB100	WB150	WB200	SB200	DB300	SB400L	KBL00	SBU4A	SB500	SBU6A	DB600	HBU600	SBU8A	DB800	DB1000
100	DI101	S1NB10	WB101	WB151	WB201	SB201	DB301	SB401L	KBL01	SBU4B	SB501	SBU6B	DB601	HBU601	SBU8B	DB801	DB1001
200	DI102	S1NB20	WB102	WB152	WB202	SB202	DB302	SB402L	KBL02	SBU4D	SB502	SBU6D	DB602	HBU602	SBU8D	DB802	DB1002
400	DI104	S1NB40	WB104	WB154	WB204	SB204	DB304	SB404L	KBL04	SBU4G	SB504	SBU6G	DB604	HBU604	SBU8G	DB804	DB1004
600	DI106	S1NB60	WB106	WB156	WB206	SB206	DB306	SB406L	KBL06	SBU4J	SB506	SBU6J	DB606	HBU606	SBU8J	DB806	DB1006
800	DI108	S1NB80	WB108	WB158	WB208	SB208	DB308	SB408L	KBL08	SBU4K	SB508	SBU6K	DB608	HBU608	SBU8K	DB808	DB1008
1000	DI110	S1NB100	WB110	WB1510	WB210	SB210	DB310	SB410L	KBL10	SBU4M	SB510	SBU6M	DB610	HBU610	SBU8M	DB810	DB1010
Typ. R _{θJA}	40	40	40	35	35	30	12	19.0	19.0	19.0	17.0	16.0	16.0	16.0	16	12	12
Typ. R _{θJL}	15	15	15	15	15	11	8	3.4	3.4	3.4	3.3	3.1	5.7	5.7	3	5	5
Typ. R _{θJC}																	
Tc @ Rated Io (°C)	40	40	50	25	25	55	60	50	100	100	55	100	50	50	100	100	100
TA @ Rated Io (°C) (Note 2)	40	40	50	25	25	55	25	50	65	65	55	40	40	40	65	50	50
Max. VF	1.10	1.05	1.00	1.00	1.00	1.05	0.95	0.95	0.95	0.95	1.00	0.95	0.95	0.95	0.95	0.95	0.95
Typ. VF							0.90	0.90	0.90	0.90	0.95	0.90	0.90	0.90	0.90	0.90	0.90
Tj (Max) (°C)	150	150	150	150	150	150	150	150	150	150	150	150	150	150	150	150	150
Avalanche Voltages							Note 3	Note 3							Note 3	Note 3	Note 3
V(BR)Min							Note 4	Note 4							Note 4	Note 4	Note 4
V(BR)Max																	

NOTES: (1) Io is Total Bridge Output
 (2) Tc - With Bridge Mounted on an Aluminum Plate; Ta - With Bridge Mounted on PC Board (See Data Sheets For Details)
 (3) V(BR)Min = 450 Volts For All 400 Volt Controlled Avalanche Bridges (i.e., Those Bridges With a Part Number Beginning With The Letter "A")
 650 Volts For All 600 Volt Controlled Avalanche Bridges
 850 Volts For All 800 Volt Controlled Avalanche Bridges
 (4) V(BR)Max = 900 Volts For All 400 Volt Controlled Avalanche Bridges
 1100 Volts For All 600 Volt Controlled Avalanche Bridges
 1300 Volts For All 800 Volt Controlled Avalanche Bridges

PART NUMBERING SYSTEM 1 TO 10 AMP BRIDGES

BODY ID	DEFINITION
DB	Rectangular Package, Small Vertical Elevation
DI	Duall-Line 4 Pin Package
HBU	Special Package, Ideal For Motor Applications
SB	Vertical or Side-Looking Package
S1NB	Duall-Line 4 Pin Package
SBU	Side-Looking Package w/Center Mounting Hole
SDB	Side Looking DB Package
SDI	Duall-Line 4 Pin Package
WB	Cylindrical Package

(a) Example: DB600 or HBU606 (6 Amp, 50 Volt, or 6 Amp, 600 Volt in Rectangular or Special Package)

(A) BB(B) C(C) VV

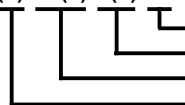

Blocking Voltage Reference (50 - 1000 Volts) - 2 Digits, e.g., 00 = 50 Volts; 02 = 200 Volts, 10 = 1000 Volts.

Current Reference (Average Forward Rectified Current For Total Bridge) - 1 or 2 Digits.

Body Type Designator. Two or 3 Letters - See Table at Right.

The Letter "A" Before the Body Designators SB, DB, or HBU Indicates Bridge is Part of the "Avalanche" Series

Note: The SB400/ASB400 Series Part Numbers Incorporate a Suffix Letter (L) to Indicate the "+" Output of the Rectifier is on The Longest Lead.
 The New Bridge Series, S1NBVV(V), Incorporates the 1 Amp Current Reference in the Body Designator and Uses the Final 2 or 3 Digits as a Voltage Reference, i.e., 05 = 50 Volts, 10 = 100 Volts, 100 = 1000 Volts

(b) Example: SBU6A (6 Amp, 50 Bridge Rectifier, Side Looking Package)

SBU C L



Blocking Voltage Reference (50 - 1000 Volts) - 1 Letter. A, B, D, G, J, K, M = 50, 100, 200, 400, 600, 800, 1000 Volts, Respectively.

Current Reference (Average Forward Rectified Current) - 1 Digit, Range 4-8 Amps.

Side Looking Package With Mounting Hole

15 - 50 AMP BRIDGES

Example: DB3504 or ADB3504P (35 Amp, 400 Volt Bridges. The Second Bridge is One of The "Avalanche" Series and Provided in a Plastic Package, i.e., With Integrally Molded Heat Sink)

(A) (S)DB AA VV (P) (W) or (T)



Suffix Indicating Wire (W) or Fast-on Terminals (T)

When Present, Indicates Plastic Package With The Heat Sink Integrated into The Bridge Encapsulation (See Figure 2 on Facing Page)

Blocking Voltage Reference (50 - 1000 Volts) - 2 Digits, e.g., 00 = 50 Volts, 05 = 500 Volts, 10 = 1000 Volts

Current Reference (Average Forward Rectified Current) - 2 Digits, Range: 15 - 50 Amps

Body Type Designator. Rectangular (DB) Body Used in These Products. When "S" is Present, Indicates Side-Looking (In-Line) Package

The Letter "A" Before the Body Designator, DB, Indicates Bridge is Part of the "Avalanche" Series

SILICON BRIDGE RECTIFIER QUICK SELECTION GUIDE (Continued)

SEE SECTION E

DIOTEC's 15, 25, and 35 Amp Bridges are offered with an electrically isolated metal case or epoxy case with integral heatsink, Figures 1 and 2, respectively. The metal or epoxy case, in turn, can be obtained with Fast-On Terminals or Wire Leads. DIOTEC offers 40 and 50 Amp in-line bridges also. These in-line bridges are only available in the epoxy case with wire leads. The 50 Amp bridge is also available in the epoxy case with Fast-On Terminals or Wire Leads.

VRRM	Io, AVERAGE RECTIFIED FORWARD CURRENT (AMPERES)															
	15		25				35				40		50			
	SEE FIG 1 BELOW ⌚	SEE FIG 2 BELOW ⌚	SEE FIG 1 BELOW ⌚	SEE FIG 2 BELOW ⌚	SEE FIG 1 BELOW ⌚	SEE FIG 2 BELOW ⌚	SEE FIG 1 BELOW ⌚	SEE FIG 2 BELOW ⌚	SEE FIG 3 BELOW ⌚	SEE FIG 3 BELOW ⌚	SEE FIG 2 BELOW ⌚					
50	DB1500	DB1500P	DB2500	DB2500P	DB3500	DB3500P	SDB4000	SDB5000	DB5000P							
100	DB1501	DB1501P	DB2501	DB2501P	DB3501	DB3501P	SDB4001	SDB5001	DB5001P							
200	DB1502	DB1502P	DB2502	DB2502P	DB3502	DB3502P	SDB4002	SDB5002	DB5002P							
400	ADB1504	DB1504	ADB1504P	DB1504P	ADB2504	DB2504	ADB2504P	DB2504P	ADB3504	DB3504	ADB3504P	DB3504P	SDB4004	SDB5004	ADB5004P	DB5004P
600	ADB1506	DB1506	ADB1506P	DB1506P	ADB2506	DB2506	ADB2506P	DB2506P	ADB3506	DB3506	ADB3506P	DB3506P	SDB4006	SDB5006	ADB5006P	DB5006P
800	ADB1508	DB1508	ADB1508P	DB1508P	ADB2508	DB2508	ADB2508P	DB2508P	ADB3508	DB3508	ADB3508P	DB3508P	SDB4008	SDB5008	ADB5008P	DB5008P
1000	DB1510	DB1510P	DB2510	DB2510P	DB3510	DB3510P	SDB4010	SDB5010	DB5010P							
RθJC	1.8	1.4	1.6	1.2	1.6	1.2	1.1	1.1	1.1							
Tc @ Rated Io (°C)	50	50	50	50	50	50	55	55	55							
Max. Vf Typ. Vf	1.03	1.03	1.03	1.03	1.03	1.03	SEENOTE (8)	SEENOTE (8)	SEE NOTE (8)							
Tj (Max) (°C)	150	150	150	150	150	150	175	175	175							
Avalanche Voltages V(BR)Min V(BR)Max	Note 6 Note 7	Note 3 Note 4	Note 6 Note 7	Note 6 Note 7	Note 6 Note 7	Note 6 Note 7	Note 6 Note 7	Note 6 Note 7	Note 6 Note 7							

Notes: (5) V_{BRMIN} = 450 Volts For All 400 Volt Controlled Avalanche Bridges (i.e. Those Bridges With a Part Number Starting With The Letter "A")
650 Volts For All 600 Volt Controlled Avalanche Bridges, and
850 Volts For All 800 Volt Controlled Avalanche Bridges.

(7) V_{BRMAX} = 900 Volts For All 400 Volt Controlled Avalanche Bridges,
1100 Volts For All 600 Volt Controlled Avalanche Bridges, and
1300 Volts For All 800 Volt Controlled Avalanche Bridges.

(8) Max. V_f = 0.96 (V_k = 100 to 600 Volts); 1.00 (V_k = 800 to 1000 Volts)
Typ. V_f = 0.93 (V_k = 100 to 600 Volts); 0.97 (V_k = 800 to 1000 Volts)

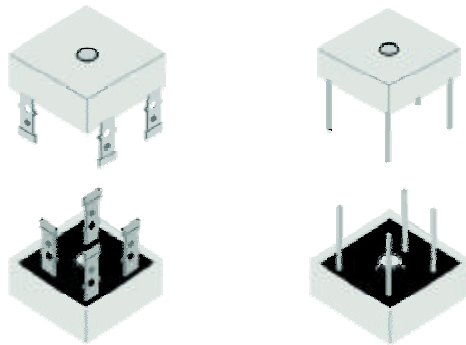

FAST-ON TERMINALS

WIRE LEADS

FIGURE 1. ELECTRICALLY ISOLATED METAL CASE

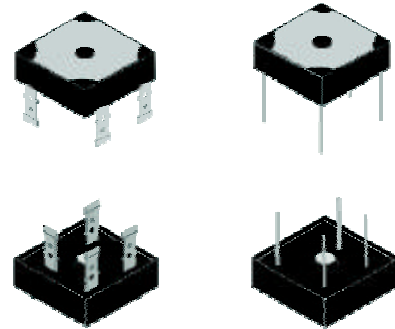

FAST-ON TERMINALS

WIRE LEADS

FIGURE 2. EPOXY CASE WITH INTEGRALLY MOLDED HEAT SINK



FIGURE 3. IN-LINE CONFIGURATION. EPOXY CASE WITH INTEGRALLY MOLDED HEAT SINK

FAST RECOVERY BRIDGE RECTIFIER QUICK SELECTION GUIDE

SEE SECTION G

DIOTEC's Fast Recovery Bridge Rectifiers provide switching times ranging from 200nS to 500nS, some of the fastest in the industry! These bridges are available with current ratings up to 35 Amps at 1000 Volts. Switching times at these ratings are a maximum of 500nS! Contact DIOTEC with your special requirements.

	I _o , AVERAGE RECTIFIED FORWARD CURRENT (AMPERES)								
	1	1.5	2	3	6	25	25	35	
						SEE FIGURE 1 RIGHT	SEE FIGURE 2 RIGHT	SEE FIGURE 1 RIGHT	SEE FIGURE 2 RIGHT
VRRM	50	50	50	50	50	50	50	50	50
	FDI100	FWB150	FSB200	FDB300	FDB600	FDB2500	FDB2500P	FDB3500	FDB3500P
	FDI101	FWB151	FSB201	FDB301	FDB601	FDB2501	FDB2501P	FDB3501	FDB3501P
	FDI102	FWB152	FSB202	FDB302	FDB602	FDB2502	FDB2502P	FDB3502	FDB3502P
	FDI104	FWB154	FSB204	FDB304	FDB604	FDB2504	FDB2504P	FDB3504	FDB3504P
	FDI106	FWB156	FSB206	FDB306	FDB606	FDB2506	FDB2506P	FDB3506	FDB3506P
	FDI108	FWB158	FSB208	FDB308	FDB608	FDB2508	FDB2508P	FDB3508	FDB3508P
	FDI110	FWB150	FSB210	FDB310	FDB610	FDB2510	FDB2510P	FDB3510	FDB3510P
Typ. R _{θJA} Typ. R _{θJC}	40	35	30	8	5.7	1.6	1.2	1.6	1.2
T _c @ Rated I _o (°C) T _A @ Rated I _o (°C)	40	55	55	50	50	55	55	55	55
Max. VF	1.3	1.3	1.3	1.3	1.3	1.3	1.3	1.3	1.3
T _J (Max) (°C)	150	150	150	150	150	150	150	150	150
TRR (nS)	TRR = 200nS: 0 < VRRM < 300; TRR = 300nS: 300 < VRRM < 700; TRR = 500nS: 700 < VRRM < 1100								

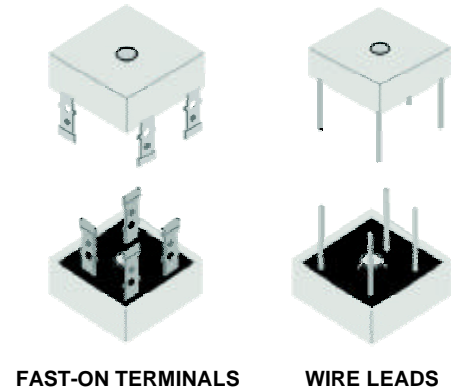

FAST-ON TERMINALS WIRE LEADS

FIGURE 1. ELECTRICALLY ISOLATED METAL CASE

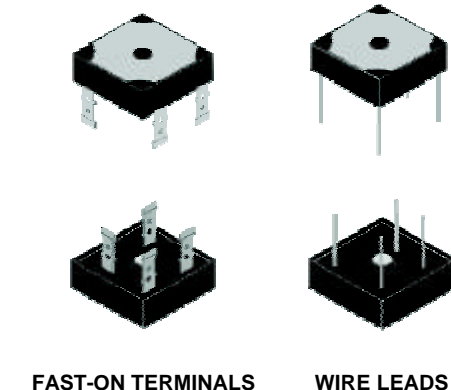

FAST-ON TERMINALS WIRE LEADS

FIGURE 2. EPOXY CASE WITH INTEGRALLY MOLDED HEAT SINK

PART NUMBERING SYSTEM

Example: FDI106 or FDB2506 (1 Amp, 600 Volt, or 25 Amp, 600 Volt Fast Recovery Bridge Rectifier. The First Product is Housed in a Dual In-Line Package; The Second in a Rectangular Package)

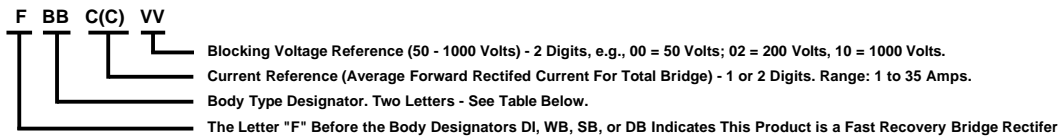





BODY ID	DEFINITION
DB	Rectangular Package, Small Vertical Elevation
DI	Dual In-Line 4 Pin Package
WB	Cylindrical Package

GENERAL PURPOSE SILICON DIODE QUICK SELECTION GUIDE

SEE SECTION H

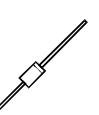
DIOTEC's offers a number of axial lead, low cost, general purpose diodes which will satisfy a wide range of applications. A number these diodes are available as DIOTEC's SOFT GLASS DIODES (SOFT GLASS DIODE is a DIOTEC Registered Trademark). These SOFT GLASS DIODES provide the highest degree of operational reliability, efficiency, and high temperature/mechanical stress reliability. More information on SOFT GLASS DIODES may be found in Appendix X.

	I _o , AVERAGE RECTIFIED FORWARD CURRENT (AMPERES)									
	1				1.5	2	3		4	6
	DO-41				DO-15	DO-41	DO-27		DO-27	
VRRM										
	SOFT GLASS DIODES					SOFT GLASS DIODES	SOFT GLASS DIODES			
50	1N4001	1N4001G	GP100	S1A	1N5391	GP200	IN5400	1N5400G	GP400	GP600
100	1N4002	1N4002G	GP101	S1B	1N5392	GP201	IN5400	1N5400G	GP401	GP601
200	1N4003	1N4003G	GP102	S1D	1N5393	GP202	IN5400	1N5400G	GP402	GP602
400	1N4004	1N4004G	GP104	S1G	1N5395	GP204	IN5400	1N5400G	GP404	GP604
600	1N4005	1N4005G	GP106	S1J	1N5397	GP206	IN5400	1N5400G	GP406	GP606
800	1N4006	1N4006G	GP108	S1K	1N5398	GP208	IN5400	1N5400G	GP408	GP608
1000	1N4007	1N4007G	GP110	S1M	1N5399	GP210	IN5400	1N5400G	GP410	GP610
I _{FSM} (Amps)	50	50	50	30	60	70	200	200	200	400
T _A @ Rated I _o (°C)	75	75	75	100 Note 1	75	50	75	75	75	75
T _J (Max) (°C)	175	175	175	150	175	175	175	175	175	175

NOTES: (1) Temperature Rating: T_L=100° C

PART NUMBERING SYSTEM

Example: GP102 (1 Amp, 200 Volt, Axial Lead General Purpose SOFT GLASS DIODE (SOFT GLASS DIODE is a DIOTEC Electronics Registered Trademark))

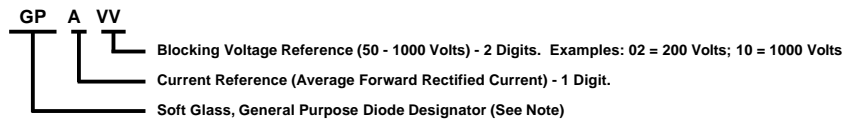

NOTE: The Single Exception to This System is The GP600 Series of Diodes. These diodes are ARE NOT SOFT GLASS DIODES.





1N4000, 1N5391, 1N5400 - JEDEC Type Designation

1N4000G, 1N5400G - DIOTEC SOFT GLASS Equivalent of the JEDEC Type Designated Diode

FAST RECOVERY SILICON DIODE QUICK SELECTION GUIDE

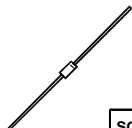
SEE SECTION H

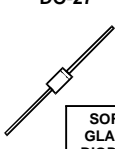
DIOTEC's Fast Recovery Diodes exhibit switching times in the range of 4 to 500nS. Additionally, many of these products are **SOFT GLASS DIODES** (**SOFT GLASS DIODE** is a DIOTEC Registered Trademark). These **SOFT GLASS DIODES** provide the highest degree of operational efficiency and high temperature/mechanical stress reliability. More information on **SOFT GLASS DIODES** may be found in Appendix X.

VRRM	Io, AVERAGE RECTIFIED FORWARD CURRENT (AMPERES)								
	0.15	1		2		3	6	8	
	DO-35 	DO-41 		DO-41 		DO-27 	G-6A 	TO-220AC 	
50		1N4933	RP100	RGP100	RGP200	RP300	RGP300	RP600	RGP800
100	1N4148 (Note 1)	1N4934	RP101	RGP101	RGP201	RP301	RGP301	RP601	RGP801
200		1N4935	RP102	RGP102	RGP202	RP302	RGP302	RP602	RGP802
400		1N4936	RP104	RGP104	RGP204	RP304	RGP304	RP604	RGP804
600		1N4937	RP106	RGP106	RGP206	RP306	RGP306	RP606	RGP806
800			RP108	RGP108	RGP208	RP308	RGP308	RP608	
1000			RP110	RGP110	RGP210	RP310	RGP310	RP610	
I _{FSM} (Amps)	Note 2	30	30	50	60	200	200	300	150
T _c @ Rated I _o (°C)									110
T _A @ Rated I _o (°C)	75	75	75	75	75	55	55	60	
T _J (Max) (°C)	175	175	175	175	175	175	175	175	150
T _{RR} (nS)	4	200	T _{RR} = 150nS: 0 < VRRM < 500; T _{RR} = 250nS: 500 < VRRM < 700; T _{RR} = 500nS: 700 < VRRM < 1100 (Note 3)						Note 4

NOTES: (1) VRRM = 75 VOLTS
 (2) ULTRA FAST SWITCHING DIODE; @ PULSE WIDTH OF 1 Sec, I_{FSM} = 1 Amp; @ PULSE WIDTH OF 1 μ Sec, I_{FSM} = 4 Amps
 (3) 300nS AVAILABLE, CONSULT FACTORY
 (4) FOR 0 < VRRM < 300, T_{RR} = 150 nS; 300 < VRRM < 500, T_{RR} = 200 nS; 500 < VRRM < 650 T_{RR} = 250 nS

PART NUMBERING SYSTEM

Example: RP102 or RGP102 (1 Amp, 200 Volt, Axial Lead Fast Recovery Diode; The Second Product (RGP102) is a **SOFT GLASS DIODE**®)

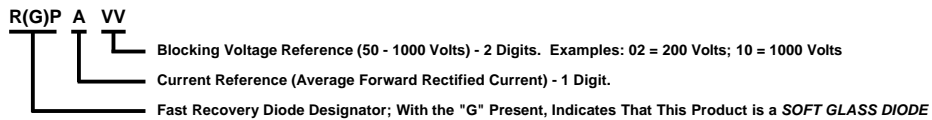

NOTE: The Single Exception to This System is The RGP800 Series of Fast Recovery Diodes. These diodes are provided in a TO-220AC Package. Additionally, These Products ARE NOT SOFT GLASS DIODES.

1N4148, 1N4933 - JEDEC Type Designation

SECTION A

SINGLE DIODE

SCHOTTKY

RECTIFIERS

AXIAL LEAD DO-41 AND DO-27 PACKAGES

1 TO 5 AMPERES

20 TO 100 VOLTS

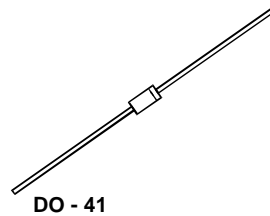

DO - 41

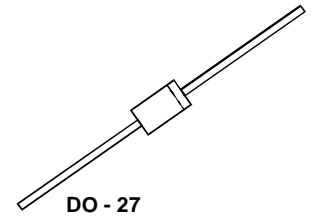

DO - 27

2 PIN TO-220AC AND TO-247AC PACKAGES

6 TO 30 AMPERES

30 TO 100 VOLTS

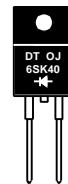

TO - 220AC

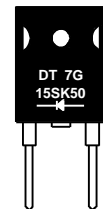

TO - 247AC

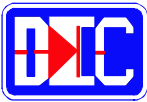

1 AMP SCHOTTKY BARRIER RECTIFIERS

FEATURES

- Metal semiconductor junction with guard ring
- Epitaxial Construction
- Low forward voltage drop
- High current capacity
- For use in low voltage, high frequency inverters, free wheeling, and polarity protection applications

MECHANICAL DATA

- Case: JEDEC DO-41, molded plastic (U/L Flammability Rating 94V-0)
- Terminals: Plated axial leads
- Soldering: Per MIL-STD 202 Method 208 guaranteed
- Polarity: Color band denotes cathode
- Mounting Position: Any
- Weight: 0.012 Ounces (0.34 Grams)

MECHANICAL SPECIFICATION

ACTUAL SIZE OF
DO-41 PACKAGE

SERIES 1N5817 - 1N5819

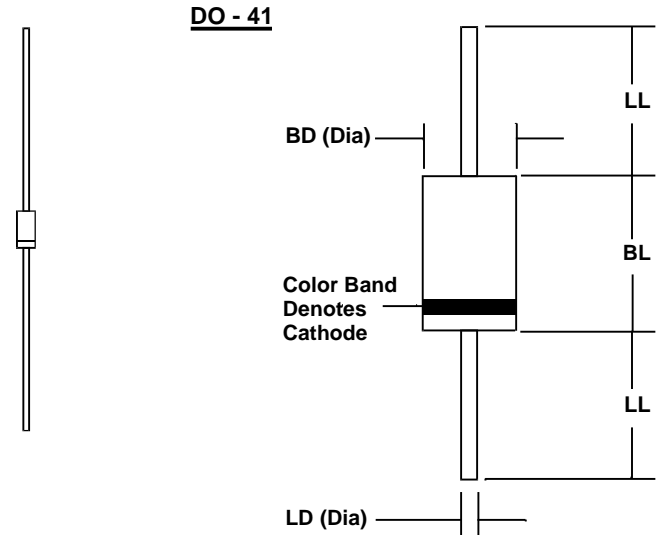

Sym	Minimum		Maximum	
	In	mm	In	mm
BL	0.160	4.1	0.205	5.2
BD	0.103	2.6	0.107	2.7
LL	1.00	25.4		
LD	0.028	0.71	0.034	0.86

MAXIMUM RATINGS & ELECTRICAL CHARACTERISTICS

Ratings at 25 °C ambient temperature unless otherwise specified.
 Single phase, half wave, 60Hz, resistive or inductive load.
 For capacitive loads, derate current by 20%.

PARAMETER (TEST CONDITIONS)	SYMBOL	RATINGS			UNITS
		1N5817	1N5818	1N5819	
Series Number		1N5817	1N5818	1N5819	
Maximum DC Blocking Voltage	V _{RM}	20	30	40	VOLTS
Maximum RMS Voltage	V _{RMS}	14	21	28	
Maximum Peak Recurrent Reverse Voltage	V _{RRM}	20	30	40	
Average Forward Rectified Current @ T _L = 90 °C (T _L measured on cathode lead, 1/32 in. from case)	I _o	1			AMPS
Peak Forward Surge Current (8.3 mSec single half sine wave superimposed on rated load)	I _{FSM}	25			
Maximum Forward Voltage at 1 Amp DC	V _{FM}	0.45	0.55	0.6	VOLTS
Maximum Forward Voltage at 3 Amps DC	V _{FM}	0.75	0.875	0.9	
Maximum Average DC Reverse Current @ T _L = 25 °C At Rated DC Blocking Voltage (Note 1) @ T _L = 100 °C	I _{RM}	1 10			mA
Typical Thermal Resistance, Junction to Ambient	R _{θJA}	80			°C/W
Typical Junction Capacitance (Note 2)	C _J	110			pF
Junction Operating Temperature Range	T _J	-65 to +125			°C
Storage Temperature Range	T _{STG}	-65 to +150			

NOTES: (1) Lead temperature reference is cathode lead 1/32 in from case.
 (2) Measured at 1MHz & applied reverse voltage of 4 volts

4.97102d101

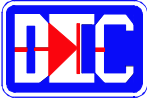

1 AMP SCHOTTKY BARRIER RECTIFIERS

RATING & CHARACTERISTIC CURVES FOR SERIES 1N5817 - 1N5819

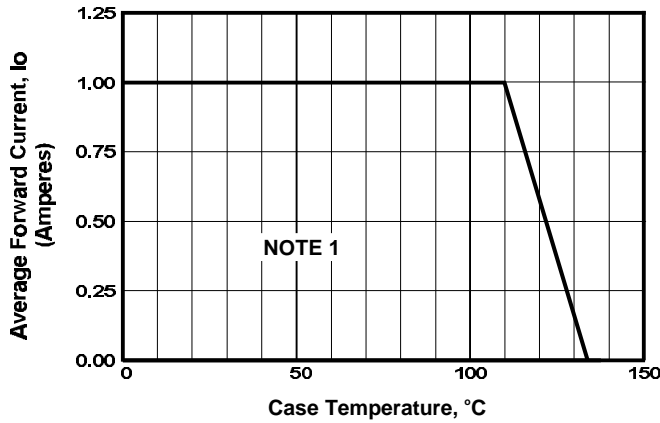

FIGURE 1. FORWARD CURRENT DERATING CURVE

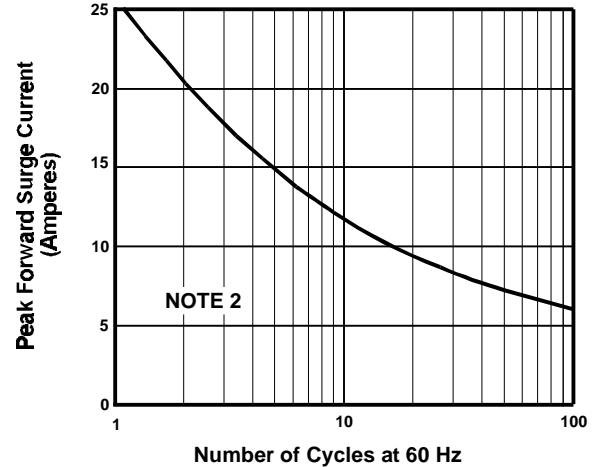

FIGURE 2. MAXIMUM NON-REPETITIVE SURGE CURRENT

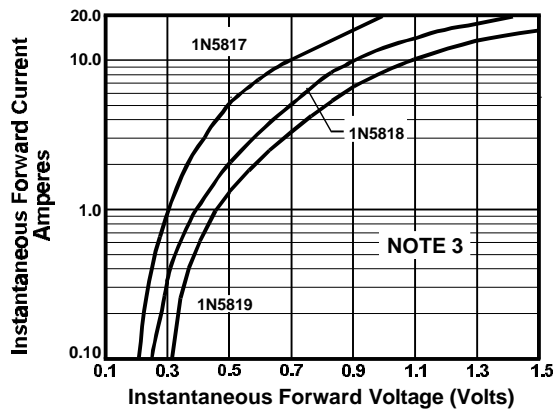

FIGURE 3. TYPICAL FORWARD CHARACTERISTICS

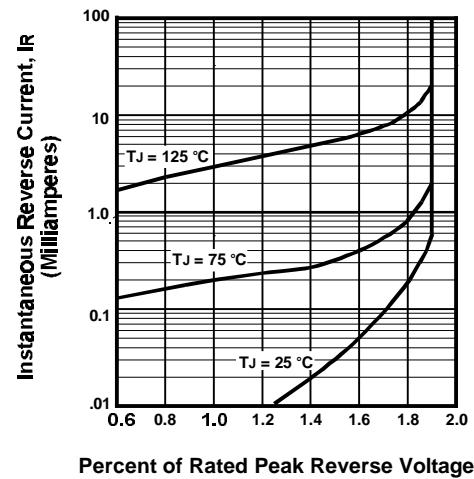

FIGURE 4. TYPICAL REVERSE CHARACTERISTICS

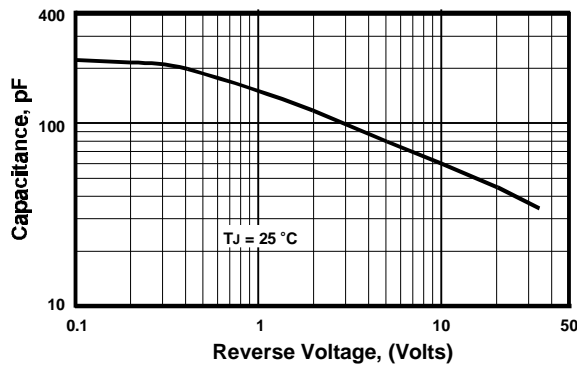
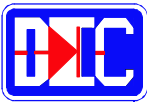

FIGURE 5. TYPICAL JUNCTION CAPACITANCE

NOTES

- (1) Single Phase, Half Wave, 60 Hz, Resistive or Inductive Load, 0.375" (9mm) Lead Length
- (2) JEDEC Method, 8.3 mSec. Single Half Sine Wave
- (3) $T_J = 25^\circ\text{C}$, Pulse Width = 300 μSec , 1.0% Duty Cycle



1 AMP SCHOTTKY BARRIER RECTIFIERS

FEATURES

- Metal semiconductor junction with guard ring
- Epitaxial Construction
- Low forward voltage drop
- High current capacity
- For use in low voltage, high frequency inverters, free wheeling, and polarity protection applications

MECHANICAL DATA

- Case: JEDEC DO-41, molded plastic (U/L Flammability Rating 94V-0)
- Terminals: Plated axial leads
- Soldering: Per MIL-STD 202 Method 208 guaranteed
- Polarity: Color band denotes cathode
- Mounting Position: Any
- Weight: 0.012 Ounces (0.34 Grams)

MECHANICAL SPECIFICATION

ACTUAL SIZE OF
DO-41 PACKAGE

SERIES SK102 - SK110

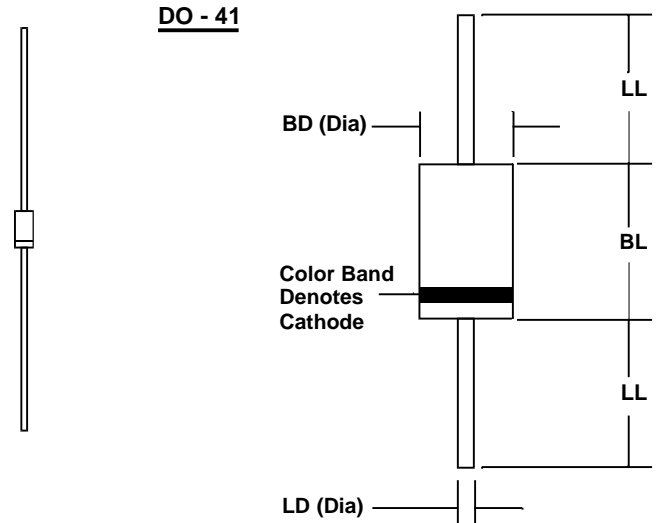

Sym	Minimum		Maximum	
	In	mm	In	mm
BL	0.160	4.1	0.205	5.2
BD	0.103	2.6	0.107	2.7
LL	1.00	25.4		
LD	0.028	0.71	0.034	0.86

MAXIMUM RATINGS & ELECTRICAL CHARACTERISTICS

Ratings at 25 °C ambient temperature unless otherwise specified.
 Single phase, half wave, 60Hz, resistive or inductive load.
 For capacitive loads, derate current by 20%.

PARAMETER (TEST CONDITIONS)	SYMBOL	RATINGS						UNITS
		SK102	SK104	SK106	SK107	SK108	SK110	
Series Number								
Maximum DC Blocking Voltage	V _{RM}	20	40	60	70	80	100	VOLTS
Maximum RMS Voltage	V _{RMS}	14	28	42	49	56	70	
Maximum Peak Recurrent Reverse Voltage	V _{RRM}	20	40	60	70	80	100	
Average Forward Rectified Current @ T _L = 90 °C (T _L measured on cathode lead, 1/32 in. from case)	I _O	1						AMPS
Peak Forward Surge Current (8.3mS single half sine wave superimposed on rated load)	I _{FSM}	40						
Maximum Forward Voltage at 1 Amp DC	V _{FM}	0.5		0.7		0.8		VOLTS
Maximum Average DC Reverse Current At Rated DC Blocking Voltage (Note 1)	I _{RM}	0.5			0.1			mA
		10			5			
Typical Thermal Resistance, Junction to Ambient	R _{θJA}	15						°C/W
Typical Junction Capacitance (Note 2)	C _J	110						pF
Junction Operating Temperature Range	T _J	-65 to +125				-65 to +150		°C
Storage Temperature Range	T _{STG}	-65 to +150						

NOTES: (1) Lead temperature reference is cathode lead 1/32 in from case.
 (2) Measured at 1MHz & applied reverse voltage of 4 volts

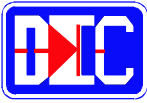

1 AMP SCHOTTKY BARRIER RECTIFIERS

RATING & CHARACTERISTIC CURVES FOR SERIES SK102 - SK107 and SERIES SK108 - SK110

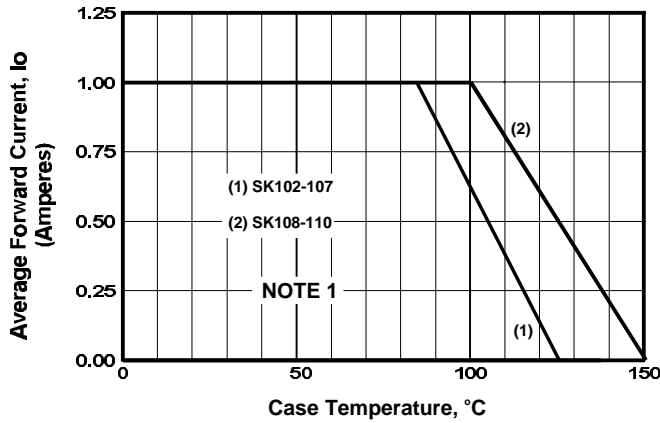

FIGURE 1. FORWARD CURRENT DERATING CURVE

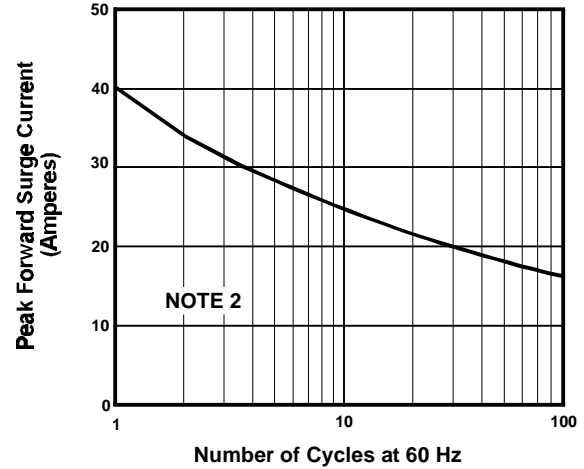

FIGURE 2. MAXIMUM NON-REPETITIVE SURGE CURRENT

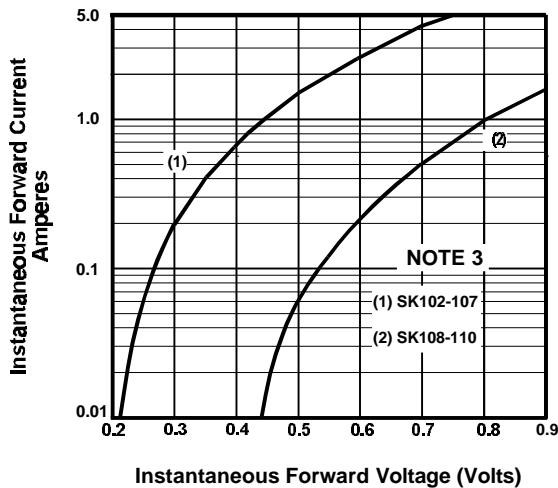

FIGURE 3. TYPICAL FORWARD CHARACTERISTICS

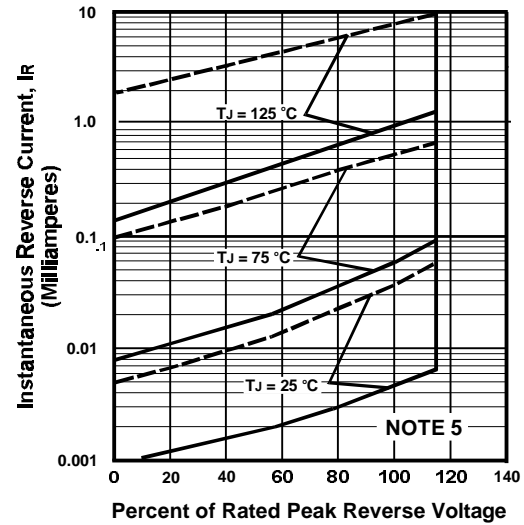

FIGURE 4. TYPICAL REVERSE CHARACTERISTICS

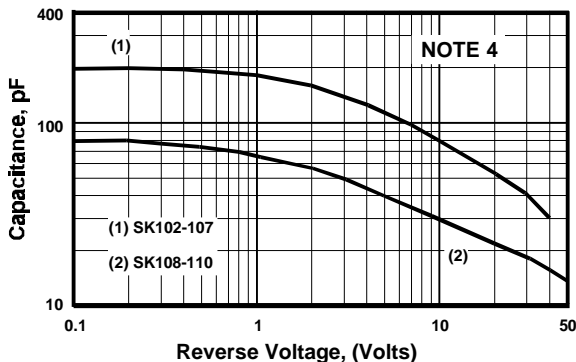
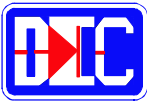

FIGURE 5. TYPICAL JUNCTION CAPACITANCE

NOTES

- (1) Single Phase, Half Wave, 60 Hz, Resistive or Inductive Load, 0.375" (9mm) Lead Length
- (2) JEDEC Method, 8.3 mSec. Single Half Sine Wave, $T_c = 95^\circ\text{C}$
- (3) $T_J = 25^\circ\text{C}$, Pulse Width = 300 μSec , 2.0% Duty Cycle
- (4) $T_J = 25^\circ\text{C}$, $f = 1\text{MHz}$, $V_{\text{SIG}} = 50\text{ mV P-P}$
- (5) Legend for Figure 4, Typical Reverse Characteristics:

----- SK102-107
 _____ SK108-110



3 AMP SCHOTTKY BARRIER RECTIFIERS

FEATURES

- Metal semiconductor junction with guard ring
- Epitaxial Construction
- Low forward voltage drop
- High current capacity
- For use in low voltage, high frequency inverters, free wheeling, and polarity protection applications

MECHANICAL DATA

- Case: JEDEC DO-27, molded plastic (U/L Flammability Rating 94V-0)
- Terminals: Plated axial leads
- Soldering: Per MIL-STD 202 Method 208 guaranteed
- Polarity: Color band denotes cathode
- Mounting Position: Any
- Weight: 0.04 Ounces (1.12 Grams)

MECHANICAL SPECIFICATION

ACTUAL SIZE OF
DO-27 PACKAGE

SERIES 1N5820 - 1N5822

DO-27

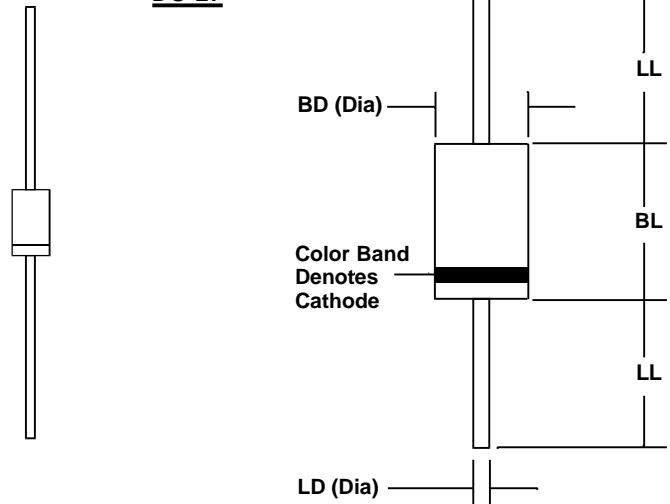

Sym	Minimum		Maximum	
	In	mm	In	mm
BL			0.365	9.28
BD			0.205	5.2
LL	1.00	25.4		
LD	0.048	1.2	0.052	1.3

MAXIMUM RATINGS & ELECTRICAL CHARACTERISTICS

Ratings at 25 °C ambient temperature unless otherwise specified.
 Single phase, half wave, 60Hz, resistive or inductive load.
 For capacitive loads, derate current by 20%.

PARAMETER (TEST CONDITIONS)	SYMBOL	RATINGS			UNITS
		1N5820	1N5821	1N5822	
Series Number		1N5820	1N5821	1N5822	
Maximum DC Blocking Voltage	VRM	20	30	40	VOLTS
Maximum RMS Voltage	VRMS	14	21	28	
Maximum Peak Recurrent Reverse Voltage	VRRM	20	30	40	
Average Forward Rectified Current @ TL = 90 °C (TL measured on cathode lead, 1/32 in, from case)	Io	3			AMPS
Peak Forward Surge Current (8.3 mSec single half sine wave superimposed on rated load)	IFSM	80			
Maximum Forward Voltage at 3 Amps DC	VFM	0.475	0.5	0.525	VOLTS
Maximum Forward Voltage at 9.4 Amps DC	VFM	0.85	0.9	0.95	
Maximum Average DC Reverse Current @ TA = 25°C At Rated DC Blocking Voltage (Note 1) @ TA = 100°C	IRM	2 20			mA
Typical Thermal Resistance, Junction to Ambient	RθJA	28			°C/W
Typical Junction Capacitance (Note 2)	CJ	110			pF
Junction Operating Temperature Range	TJ	-65 to +125			°C
Storage Temperature Range	TSTG	-65 to +150			

NOTES: (1) Measured at pulse width 300 μSec & 2.0% duty cycle.
 (2) Measured at 1MHz & applied reverse voltage of 4 volts.

4.971sb0301

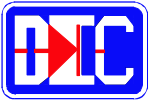

3 AMP SCHOTTKY BARRIER RECTIFIERS

RATING & CHARACTERISTIC CURVES FOR SERIES 1N5820 - 1N5822

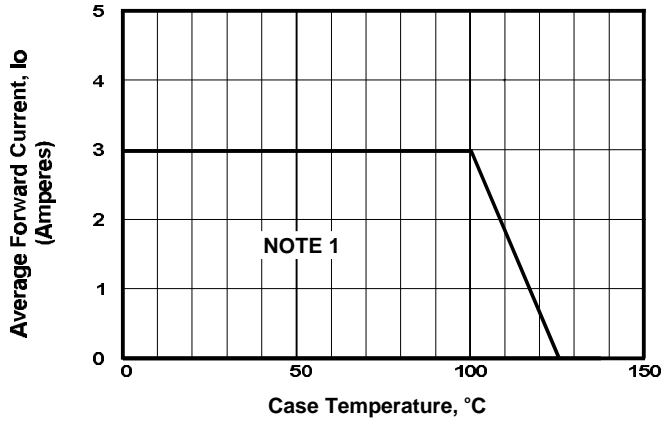

FIGURE 1. FORWARD CURRENT DERATING CURVE

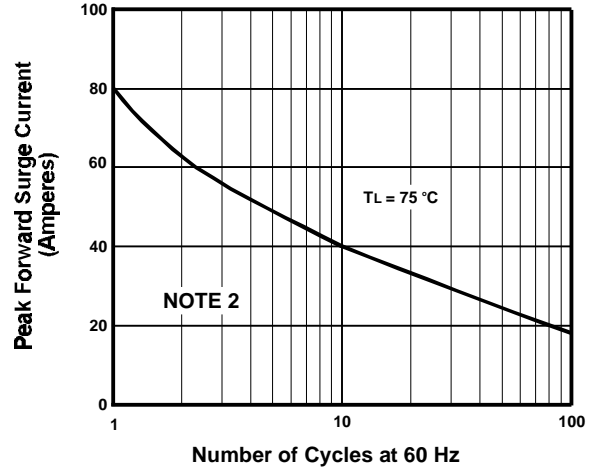

FIGURE 2. MAXIMUM NON-REPETITIVE SURGE CURRENT

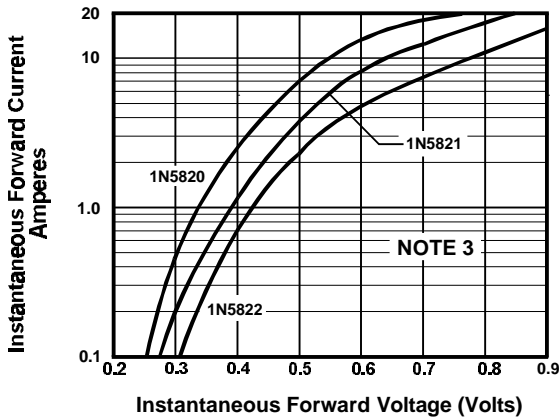

FIGURE 3. TYPICAL FORWARD CHARACTERISTICS

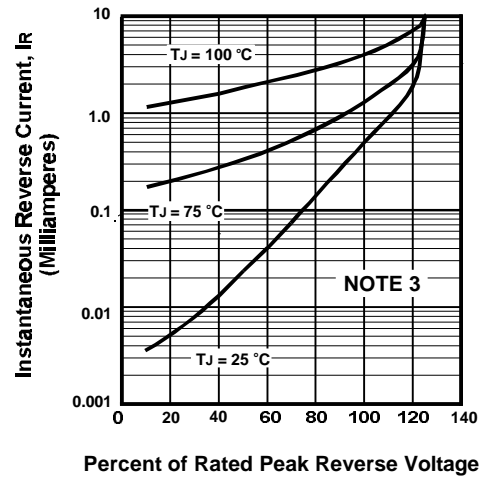

FIGURE 4. TYPICAL REVERSE CHARACTERISTICS

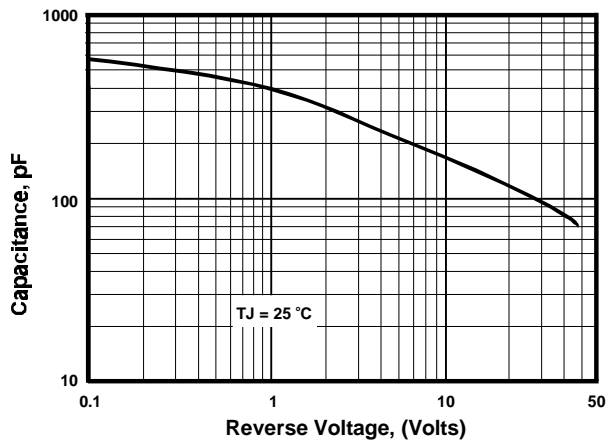
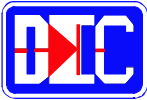

FIGURE 5. TYPICAL JUNCTION CAPACITANCE

NOTES

- (1) Single Phase, Half Wave, 60 Hz, Resistive or Inductive Load, 0.375" (9mm) Lead Length
- (2) JEDEC Method, 8.3 mSec. Single Half Sine Wave
- (3) $T_J = 25^\circ\text{C}$, Pulse Width = 300 μSec , 2.0% Duty Cycle



3 AMP SCHOTTKY BARRIER RECTIFIERS

FEATURES

- Metal semiconductor junction with guard ring
- Epitaxial Construction
- Low forward voltage drop
- High current capacity
- For use in low voltage, high frequency inverters, free wheeling, and polarity protection applications

MECHANICAL DATA

- Case: JEDEC DO-27 molded plastic (U/L Flammability Rating 94V-0)
- Terminals: Plated axial leads
- Solderability: Per MIL-STD 202 Method 208 guaranteed
- Polarity: Color band denotes cathode
- Mounting Position: Any
- Weight: 0.04 Ounces (1.12 Grams)

MECHANICAL SPECIFICATION

ACTUAL SIZE OF
DO-27 PACKAGE

SERIES SK302 - SK310

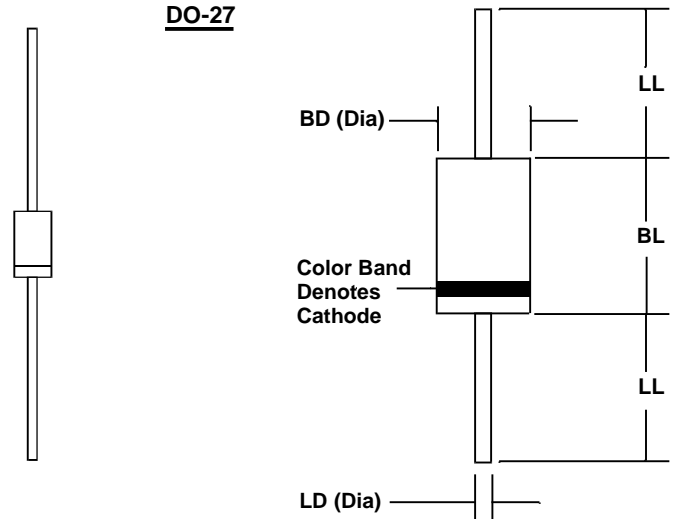

Sym	Minimum		Maximum	
	In	mm	In	mm
BL			0.365	9.28
BD			0.205	5.2
LL	1.00	25.4		
LD	0.048	1.2	0.052	1.3

MAXIMUM RATINGS & ELECTRICAL CHARACTERISTICS

Ratings at 25 °C ambient temperature unless otherwise specified.
 Single phase, half wave, 60Hz, resistive or inductive load.
 For capacitive loads, derate current by 20%.

PARAMETER (TEST CONDITIONS)	SYMBOL	RATINGS					UNITS
		SK302	SK304	SK306	SK307	SK310	
Series Number		SK302	SK304	SK306	SK307	SK310	
Maximum DC Blocking Voltage	V _{RM}	20	40	60	70	100	VOLTS
Maximum RMS Voltage	V _{RMS}	14	28	42	56	70	
Maximum Peak Recurrent Reverse Voltage	V _{R_{RM}}	20	40	60	70	100	
Average Forward Rectified Current @ T _L = 90 °C (T _L measured on cathode lead, 1/32 in. from case))	I _O	3					AMPS
Peak Forward Surge Current (8.3mS single half sine wave superimposed on rated load)	I _{FSM}	120				100	
Maximum Forward Voltage at 3 Amps DC	V _{FM}	0.5		0.7		0.8	VOLTS
Maximum Average DC Reverse Current At Rated DC Blocking Voltage (Note 1)	I _{RM}	0.5 20					mA
Typical Thermal Resistance, Junction to Ambient	R _{θJA}	20					°C/W
Typical Junction Capacitance (Note 2)	C _J	250					pF
Junction Operating Temperature Range	T _J	-65 to +125				-65 to +150	°C
Storage Temperature Range	T _{STG}	-65 to +150					

NOTES: (1) Lead temperature reference is cathode lead 1/32 in from case.
 (2) Measured at 1MHz & applied reverse voltage of 4 volts

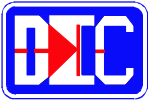

3 AMP SCHOTTKY BARRIER RECTIFIERS

RATING & CHARACTERISTIC CURVES FOR SERIES SK302 - SK310

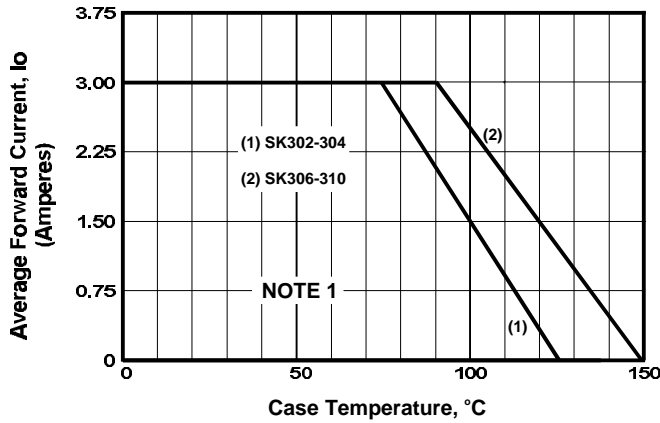

FIGURE 1. FORWARD CURRENT DERATING CURVE

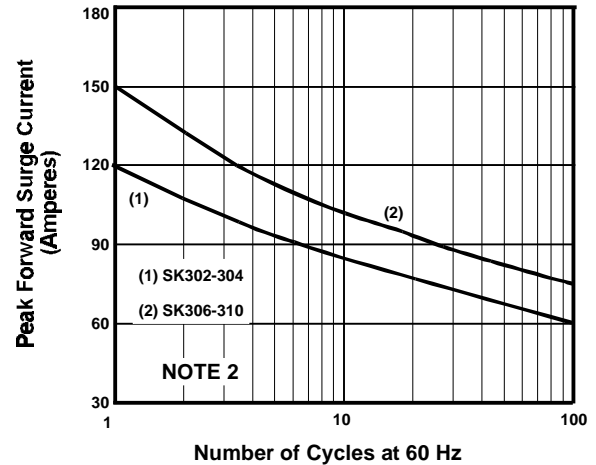

FIGURE 2. MAXIMUM NON-REPETITIVE SURGE CURRENT

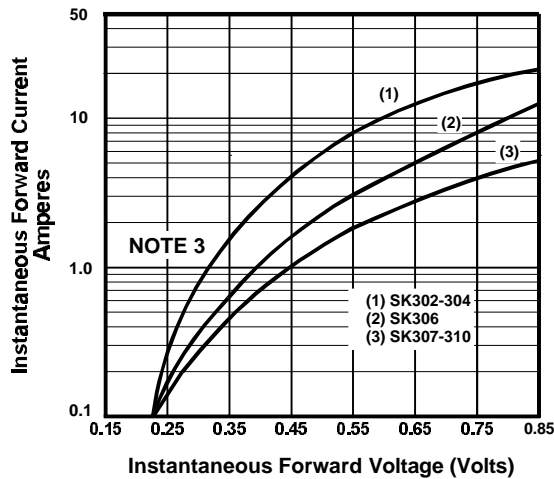

FIGURE 3. TYPICAL FORWARD CHARACTERISTICS

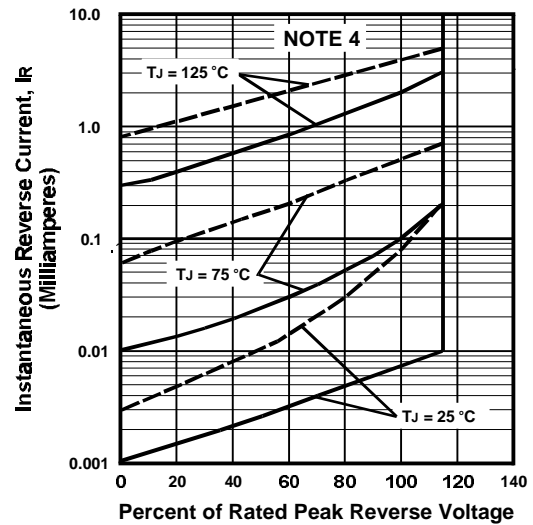
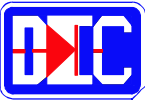

FIGURE 4. TYPICAL REVERSE CHARACTERISTICS

NOTES

- (1) Single Phase, Half Wave, 60 Hz, Resistive or Inductive Load, 0.375" (9mm) Lead Length
- (2) JEDEC Method, 8.3 mSec. Single Half Sine Wave, $T_c = 95^\circ\text{C}$
- (3) $T_J = 25^\circ\text{C}$, Pulse Width = 300 μSec , 2.0% Duty Cycle
- (4) Legend for Figure 4, Typical Reverse Characteristics:

- - - - - SK302-306
 _____ SK307-310



5 AMP SCHOTTKY BARRIER RECTIFIERS

FEATURES

- Metal semiconductor junction with guard ring
- Epitaxial Construction
- Low forward voltage drop
- High current capacity
- For use in low voltage, high frequency inverters, free wheeling, and polarity protection applications

MECHANICAL DATA

- Case: JEDEC DO-27, molded plastic (U/L Flammability Rating 94V-0)
- Terminals: Plated axial leads
- Solderability: Per MIL-STD 202 Method 208 guaranteed
- Polarity: Color band denotes cathode
- Mounting Position: Any
- Weight: 0.04 Ounces (1.12 Grams)

MECHANICAL SPECIFICATION

ACTUAL SIZE OF
DO-27 PACKAGE

SERIES SK502 - SK510

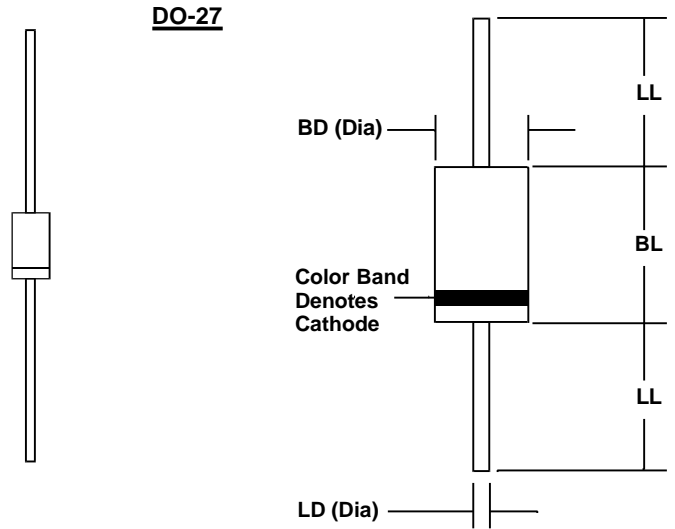

Sym	Minimum		Maximum	
	In	mm	In	mm
BL			0.365	9.28
BD			0.205	5.2
LL	1.00	25.4		
LD	0.048	1.2	0.052	1.3

MAXIMUM RATINGS & ELECTRICAL CHARACTERISTICS

Ratings at 25 °C ambient temperature unless otherwise specified.
 Single phase, half wave, 60Hz, resistive or inductive load.
 For capacitive loads, derate current by 20%.

PARAMETER (TEST CONDITIONS)	SYMBOL	RATINGS					UNITS
		SK502	SK504	SK506	SK507	SK510	
Series Number		SK502	SK504	SK506	SK507	SK510	
Maximum DC Blocking Voltage	V _{RM}	20	40	60	70	100	VOLTS
Maximum RMS Voltage	V _{RMS}	14	28	42	56	70	
Maximum Peak Recurrent Reverse Voltage	V _{RRM}	20	40	60	70	100	
Average Forward Rectified Current @ T _L = 90 °C (T _L measured on cathode lead, 1/32 in. from case)	I _O	5					AMPS
Peak Forward Surge Current (8.3mS single half sine wave superimposed on rated load)	I _{FSM}	150		120			
Maximum Forward Voltage at 5 Amps DC	V _{FM}	0.55		0.70		0.85	VOLTS
Maximum Average DC Reverse Current At Rated DC Blocking Voltage (Note 1)	I _{RM}	@ T _A = 25 °C 0.5		0.5			mA
		@ T _A = 100 °C 50		25			
Typical Thermal Resistance, Junction to Ambient	R _{θJA}	15					°C/W
Typical Junction Capacitance (Note 2)	C _J	250					pF
Junction Operating Temperature Range	T _J	-65 to +125				-65 to +150	°C
Storage Temperature Range	T _{STG}	-65 to +150					

NOTES: (1) Measured at pulse width 300 μSec and 2% duty cycle.
 (2) Measured at 1MHz and an applied reverse voltage of 4 volts.

4.9710bds01

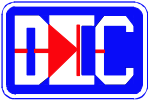

5 AMP SCHOTTKY BARRIER RECTIFIERS

RATING & CHARACTERISTIC CURVES FOR SERIES SK502 - SK510

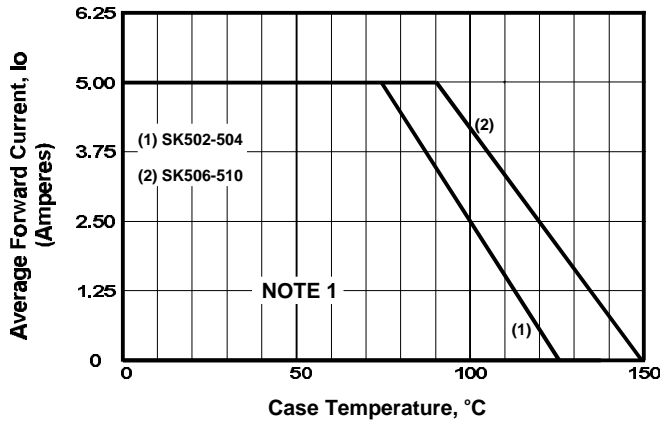

FIGURE 1. FORWARD CURRENT DERATING CURVE

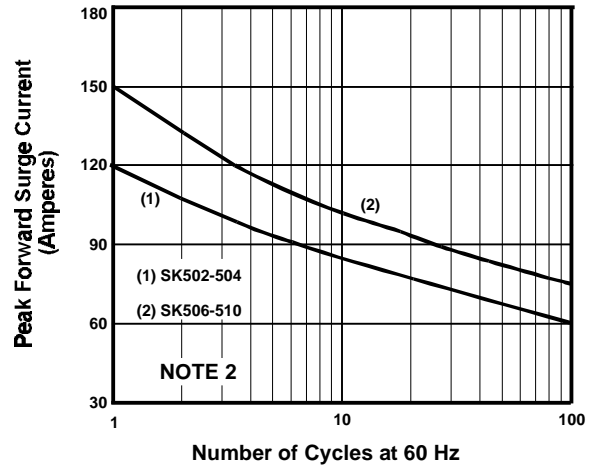

FIGURE 2. MAXIMUM NON-REPETITIVE SURGE CURRENT

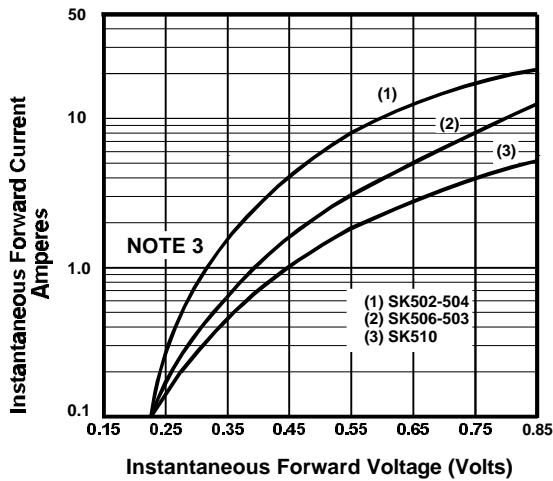

FIGURE 3. TYPICAL FORWARD CHARACTERISTICS

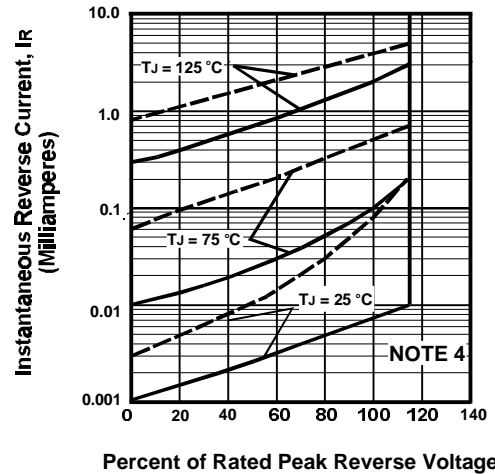
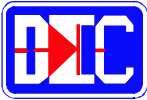

FIGURE 4. TYPICAL REVERSE CHARACTERISTICS

NOTES

- (1) Single Phase, Half Wave, 60 Hz, Resistive or Inductive Load, 0.375" (9mm) Lead Length
- (2) JEDEC Method, 8.3 mSec. Single Half Sine Wave, Tc = 95 °C
- (3) T_J = 25 °C, Pulse Width = 300 μSec, 2.0% Duty Cycle
- (4) Legend for Figure 4, Typical Reverse Characteristics:

- - - - - SK502-504
 ————— SK506-510



6 AMP SCHOTTKY BARRIER RECTIFIERS

FEATURES

- Low switching noise
- Low forward voltage drop
- Low thermal resistance
- High switching capability
- High surge capability
- High reliability

MECHANICAL DATA

- Case: TO-220 molded plastic (Fully Insulated) (U/L Flammability Rating 94V-0)
- Terminals: Rectangular pins w/ standoff
- Solderability: Per MIL-STD 202 Method 208 guaranteed
- Polarity: Diode depicted on product
- Mounting Position: Any
- Weight: 0.06 Ounces (1.7 Grams)

MECHANICAL SPECIFICATION

ACTUAL SIZE OF TO-220AC PACKAGE

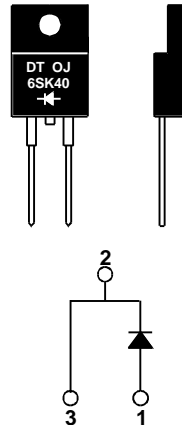

FULLY INSULATED PACKAGE

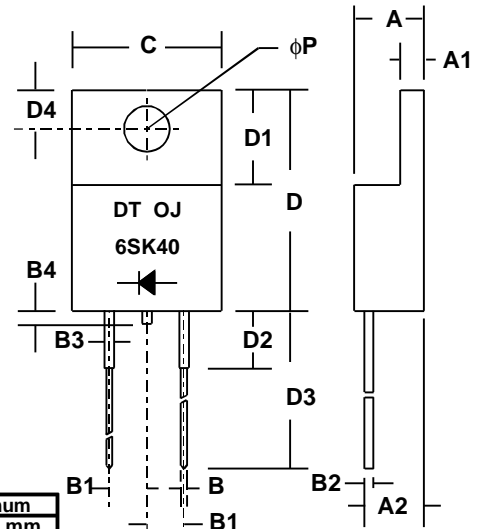

ITO - 220AC

SERIES 6SK40 - 6SK100

Sym	Minimum		Maximum	
	in	mm	in	mm
A			0.187	4.75
A1	0.121*	4.75*		
A2	0.14*	3.56*		
B	0.035	0.9	0.043	1.1
B1	0.09	2.3	0.102	2.6
B2	0.025*	0.64*		
B3	0.050*	1.27*		
B4			0.04	1.0
C			0.413	10.5
D	0.59	15.0	0.61	15.5
D1	0.262*	6.6*		
D2			0.16	4.0
D3	0.54	13.7	0.60	15.2
D4	0.108*	2.75*		
phi P	0.126*	3.2*		

* These dimensions are "Typicals".

MAXIMUM RATINGS & ELECTRICAL CHARACTERISTICS

Ratings at 25 °C ambient temperature unless otherwise specified.
 Single phase, half wave, 60Hz, resistive or inductive load.
 For capacitive loads, derate current by 20%.

PARAMETER (TEST CONDITIONS)	SYMBOL	RATINGS					UNITS
		6SK40	6SK50	6SK60	6SK70	6SK100	
Series Number							
Maximum DC Blocking Voltage	VRM	40	50	60	70	100	VOLTS
Maximum RMS Voltage	VRMS						
Maximum Peak Recurrent Reverse Voltage	VRRM						
Average Forward Rectified Current @ Tc = 100 °C	Io	6					AMPS
Peak Forward Surge Current (8.3mS single half sine wave superimposed on rated load)	IFSM	120					
Maximum Forward Voltage at 6 Amps DC	VFM	0.55		0.65		0.85	VOLTS
Maximum Average DC Reverse Current At Rated DC Blocking Voltage	IRM	0.5 50			0.1 25		mA
Typical Thermal Resistance, Junction to Case (on heat sink)	RθJC	3					°C/W
Operating and Storage Temperature Range	TJ, TSTG	-65 to +150					°C

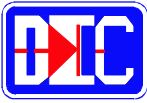

6 AMP SCHOTTKY BARRIER RECTIFIERS

RATING & CHARACTERISTIC CURVES FOR SERIES 6SK40 - 6SK100

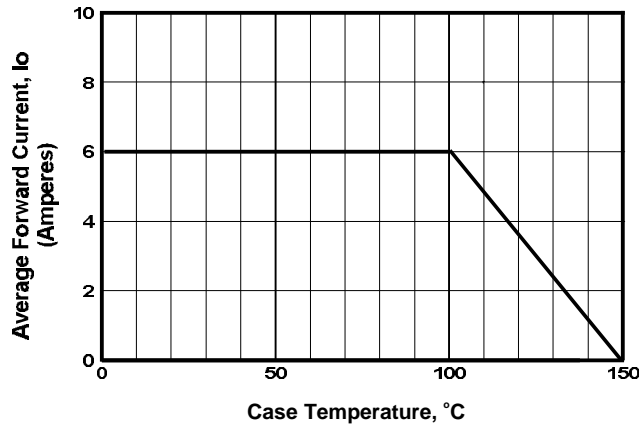

FIGURE 1. FORWARD CURRENT DERATING CURVE

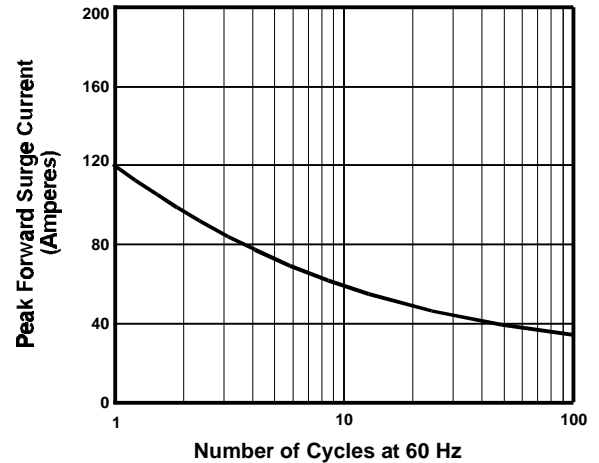

FIGURE 2. MAXIMUM NON-REPETITIVE SURGE CURRENT

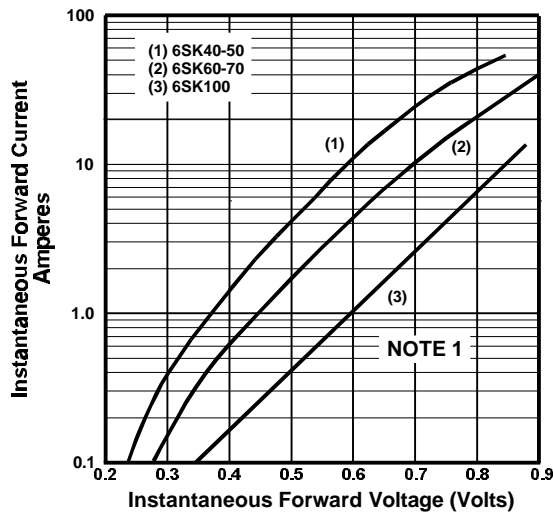

FIGURE 3. TYPICAL FORWARD CHARACTERISTICS

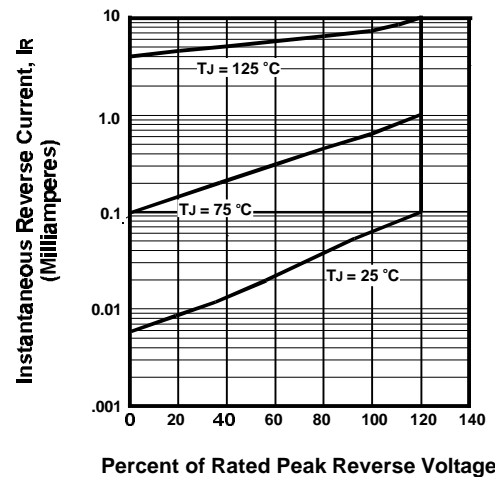

FIGURE 4. TYPICAL REVERSE CHARACTERISTICS

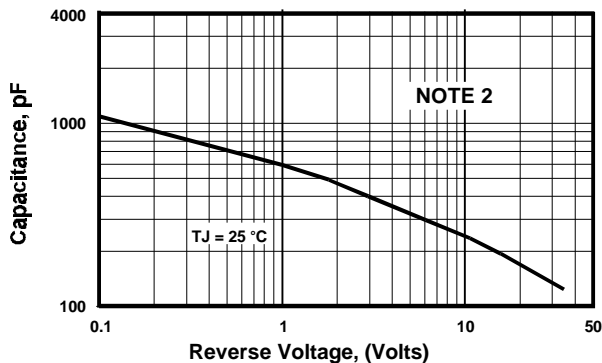
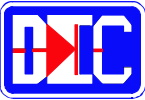

FIGURE 5. TYPICAL JUNCTION CAPACITANCE

NOTES

- (1) $T_J = 25\text{ }^\circ\text{C}$, Pulse Width = 300 μSec , 2.0% Duty Cycle
- (2) $T_J = 25\text{ }^\circ\text{C}$, $f = 1\text{ MHz}$, $V_{SIG} = 50\text{ mV P-P}$



12 AMP SCHOTTKY BARRIER RECTIFIERS

FEATURES

- Low switching noise
- Low forward voltage drop
- Low thermal resistance
- High switching capability
- High surge capability
- High reliability

MECHANICAL DATA

- Case: TO-220 molded plastic (Fully Insulated) (U/L Flammability Rating 94V-0)
- Terminals: Rectangular pins w/ standoff
- Solderability: Per MIL-STD 202 Method 208 guaranteed
- Polarity: Diode depicted on product
- Mounting Position: Any
- Weight: 0.06 Ounces (1.7 Grams)

MECHANICAL SPECIFICATION

ACTUAL SIZE OF TO-220AC PACKAGE

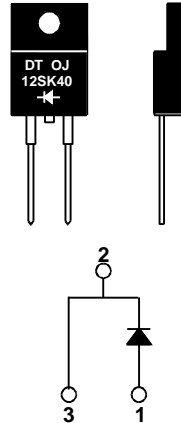

FULLY INSULATED PACKAGE

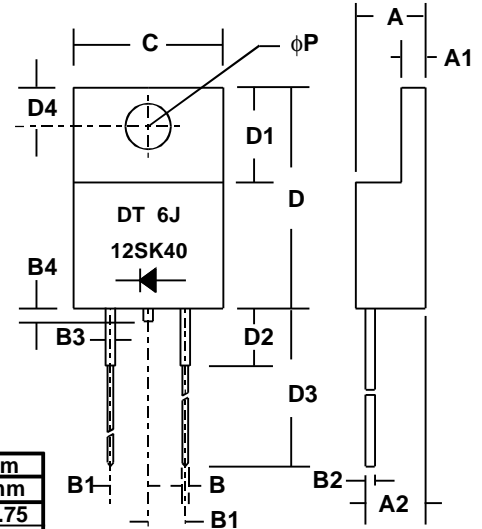

Sym	Minimum		Maximum	
	in	mm	in	mm
A			0.187	4.75
A1	0.121*	4.75*		
A2	0.14*	3.56*		
B	0.035	0.9	0.043	1.1
B1	0.09	2.3	0.102	2.6
B2	0.025*	0.64*		
B3	0.050*	1.27*		
B4			0.04	1.0
C			0.413	10.5
D	0.59	15.0	0.61	15.5
D1	0.262*	6.6*		
D2			0.16	4.0
D3	0.54	13.7	0.60	15.2
D4	0.108*	2.75*		
φP	0.126*	3.2*		

* These dimensions are "Typicals".

ITO - 220AC

SERIES 12SK40 - 12SK100

MAXIMUM RATINGS & ELECTRICAL CHARACTERISTICS

Ratings at 25 °C ambient temperature unless otherwise specified.
 Single phase, half wave, 60Hz, resistive or inductive load.
 For capacitive loads, derate current by 20%.

PARAMETER (TEST CONDITIONS)	SYMBOL	RATINGS					UNITS
		12SK40	12SK50	12SK60	12SK70	12SK100	
Series Number							
Maximum DC Blocking Voltage	VRM	40	50	60	70	100	VOLTS
Maximum RMS Voltage	VRMS						
Maximum Peak Recurrent Reverse Voltage	VRRM						
Average Forward Rectified Current @ Tc = 100 °C	Io	12					AMPS
Peak Forward Surge Current (8.3mS single half sine wave superimposed on rated load)	IFSM	180					
Maximum Forward Voltage at 12 Amps DC	VFM	0.58		0.68		0.85	VOLTS
Maximum Average DC Reverse Current At Rated DC Blocking Voltage	IRM	@ TJ = 25 °C 0.5			@ TJ = 100 °C 0.1		mA
		50			25		
Typical Thermal Resistance, Junction to Case (on heat sink)	RθJC	3					°C/W
Operating and Storage Temperature Range	TJ, TSTG	-65 to +150					°C

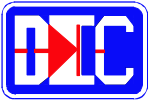

12 AMP SCHOTTKY BARRIER RECTIFIERS

RATING & CHARACTERISTIC CURVES FOR SERIES 12SK40 - 12SK100

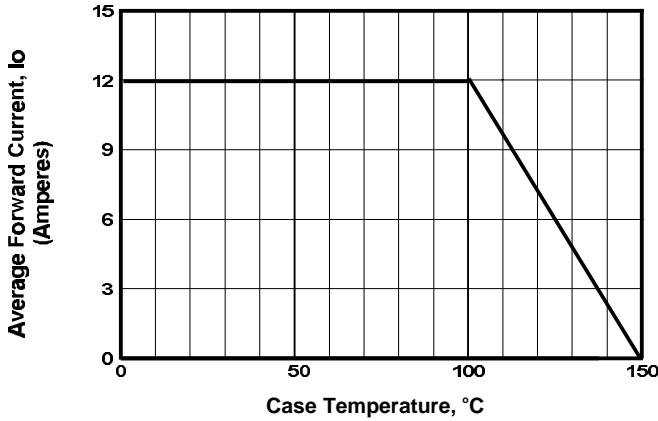

FIGURE 1. FORWARD CURRENT DERATING CURVE

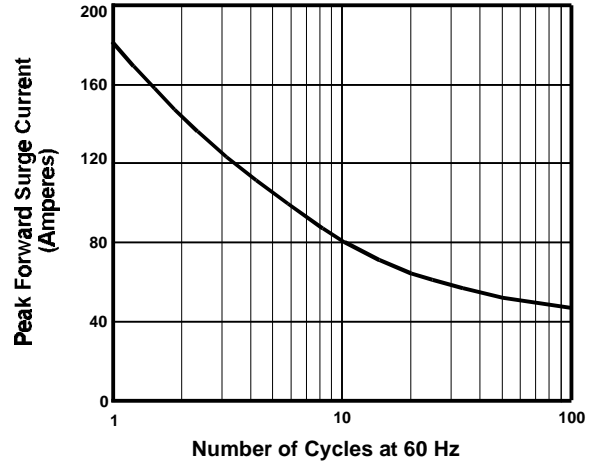

FIGURE 2. MAXIMUM NON-REPETITIVE SURGE CURRENT

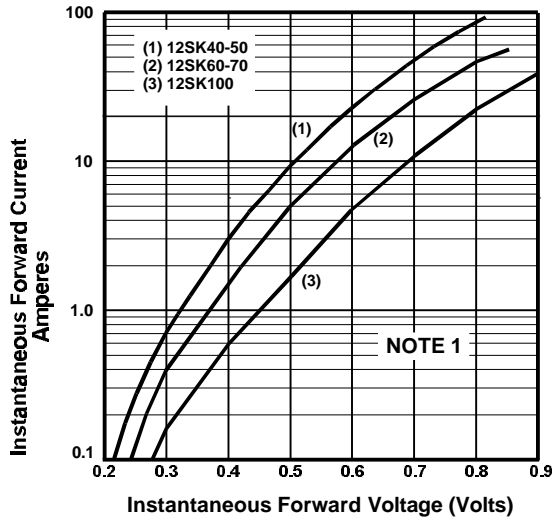

FIGURE 3. TYPICAL FORWARD CHARACTERISTICS

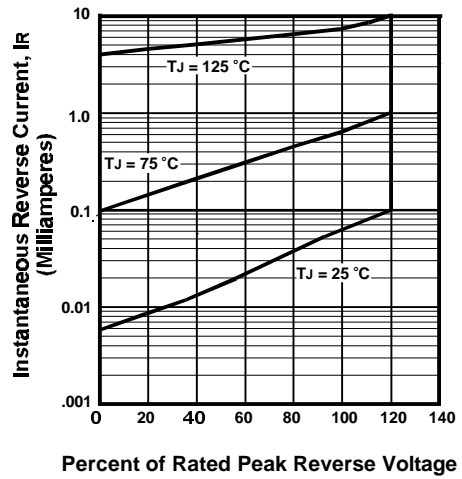

FIGURE 4. TYPICAL REVERSE CHARACTERISTICS

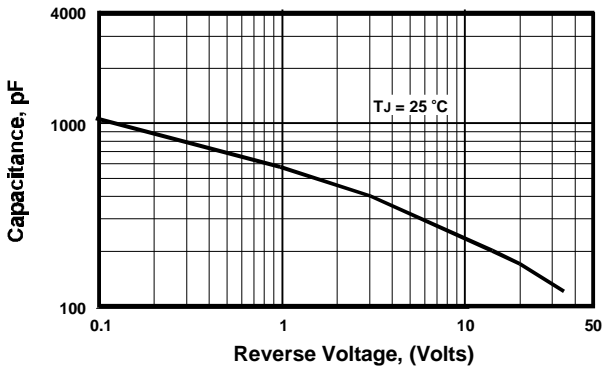
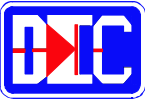

FIGURE 5. TYPICAL JUNCTION CAPACITANCE

NOTES

(1) T_J = 25 °C, Pulse Width = 300 μSec, 2.0% Duty Cycle



16 AMP SCHOTTKY BARRIER RECTIFIERS

FEATURES

- Low switching noise
- Low forward voltage drop
- Low thermal resistance
- High switching capability
- High surge capability
- High reliability

MECHANICAL SPECIFICATION

ACTUAL SIZE TO-247AC
 (TO-3PAC) PACKAGE

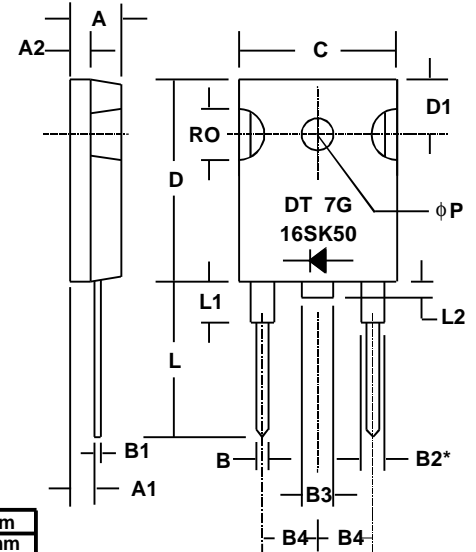
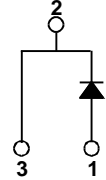
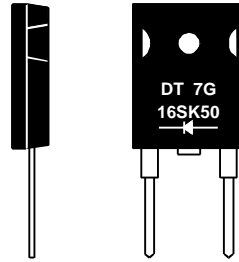

MECHANICAL DATA

- Case: TO-247 (TO-3P) molded plastic (UL Flammability Rating 94V-0)
- Terminals: Rectangular pins w/ standoff
- Solderability: Per MIL-STD 202 Method 208 guaranteed
- Polarity: Diode depicted on product
- Mounting Position: Any
- Weight: 0.19 Ounces (5.5 Grams)

Sym	Minimum		Maximum	
	in	mm	in	mm
A	0.19	4.82	0.205	5.2
A1	0.087	2.21	0.102	2.6
A2	0.075	1.9	0.085	2.16
B	0.045	1.14	0.055	1.4
B1	0.022	0.56	0.032	0.81
B2	0.079	2.01	0.094	2.39
B3	0.116	2.95	0.126	3.2
B4			0.215	5.46
C	0.602	15.29	0.625	15.88
D	0.776	19.7	0.799	20.3
D1	0.209	5.31	0.224	5.69
L	0.559	14.2	0.582	14.8
L1	0.146	3.71	0.189	4.8
L2			0.063	1.6
RO	0.209	5.3	0.224	5.7
phi P	0.13	3.3	0.145	3.7

* Applies to Pins 1 and 3

TO-247AC (TO - 3PAC)

SERIES 16SK40 - 16SK100

MAXIMUM RATINGS & ELECTRICAL CHARACTERISTICS

Ratings at 25 °C ambient temperature unless otherwise specified.
 Single phase, half wave, 60Hz, resistive or inductive load.
 For capacitive loads, derate current by 20%.

PARAMETER (TEST CONDITIONS)	SYMBOL	RATINGS					UNITS
		16SK40	16SK50	16SK60	16SK70	16SK100	
Series Number							
Maximum DC Blocking Voltage	VRM	40	50	60	70	100	VOLTS
Maximum RMS Voltage	VRMS						
Maximum Peak Recurrent Reverse Voltage	VRRM						
Average Forward Rectified Current @ Tc = 100 °C	IO	16					AMPS
Peak Forward Surge Current (8.3mS single half sine wave superimposed on rated load)	IFSM	240					
Maximum Forward Voltage at 16 Amps DC	VFM	0.55		0.65		0.85	VOLTS
Maximum Average DC Reverse Current @ TJ = 25 °C At Rated DC Blocking Voltage @ TJ = 100 °C	IRM	1 50			0.5 25		mA
Typical Thermal Resistance, Junction to Case (on heat sink)	RthetaJC	3					°C/W
Operating and Storage Temperature Range	TJ, TSTG	-65 to +150					°C

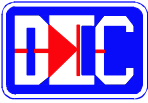

16 AMP SCHOTTKY BARRIER RECTIFIERS

RATING & CHARACTERISTIC CURVES FOR SERIES 16SK40 - 16SK100

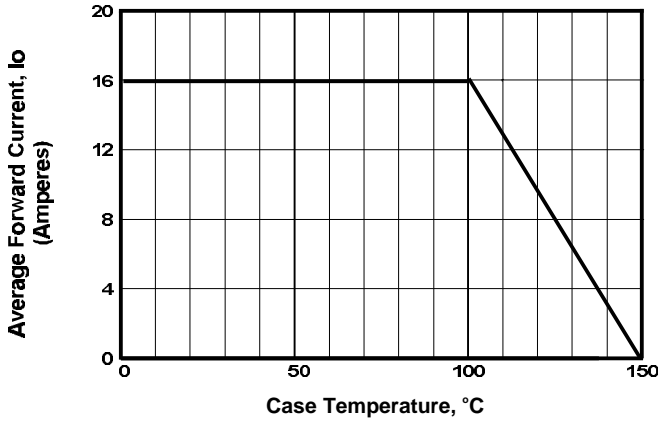

FIGURE 1. FORWARD CURRENT DERATING CURVE

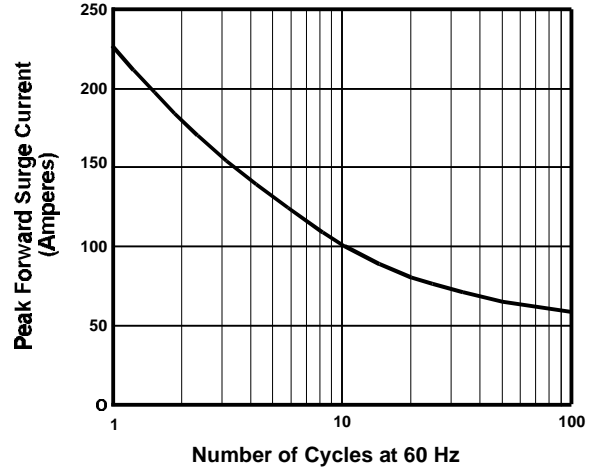

FIGURE 2. MAXIMUM NON-REPETITIVE SURGE CURRENT

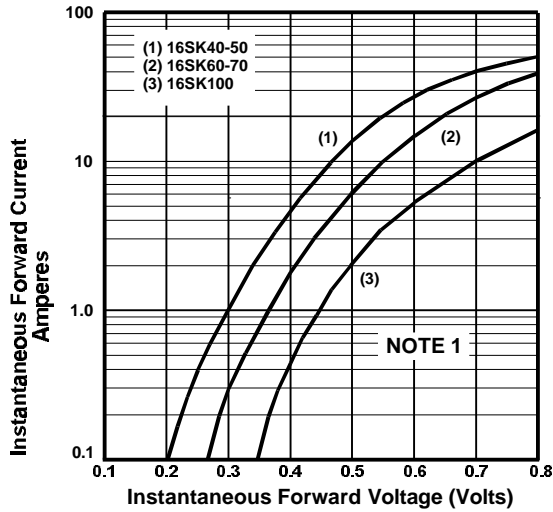

FIGURE 3. TYPICAL FORWARD CHARACTERISTICS

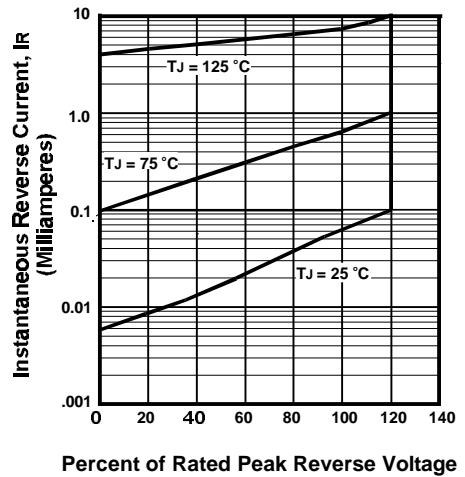

FIGURE 4. TYPICAL REVERSE CHARACTERISTICS

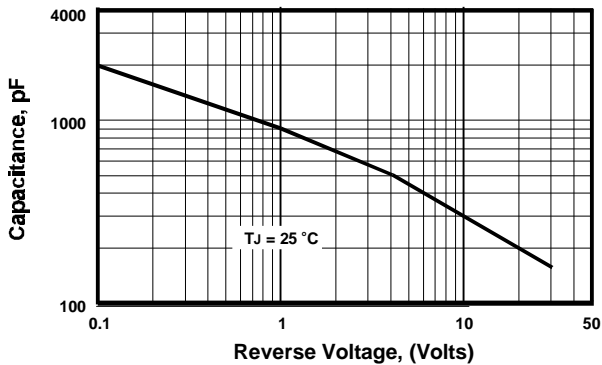
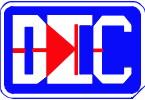

FIGURE 5. TYPICAL JUNCTION CAPACITANCE

NOTES

(1) T_J = 25 °C, Pulse Width = 300 μSec, 2.0% Duty Cycle



30 AMP SCHOTTKY BARRIER RECTIFIERS

FEATURES

- Low switching noise
- Low forward voltage drop
- Low thermal resistance
- High switching capability
- High surge capability
- High reliability

MECHANICAL DATA

- Case: TO-247 (TO-3P) molded plastic (U/L Flammability Rating 94V-0)
- Terminals: Rectangular pins w/ standoff
- Solderability: Per MIL-STD 202 Method 208 guaranteed
- Polarity: Diode depicted on product
- Mounting Position: Any
- Weight: 0.20 Ounces (5.5 Grams)

MECHANICAL SPECIFICATION

ACTUAL SIZE TO-247AC
(TO-3PAC) PACKAGE

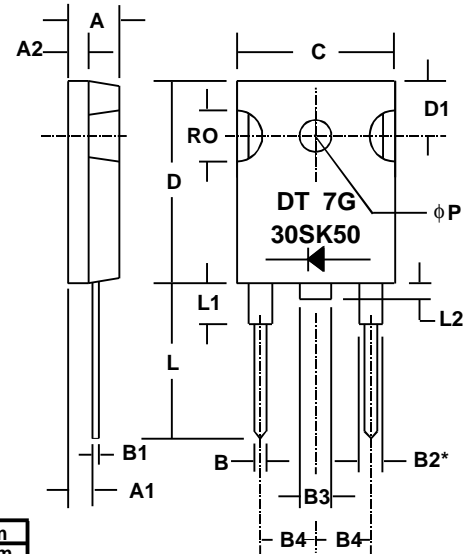
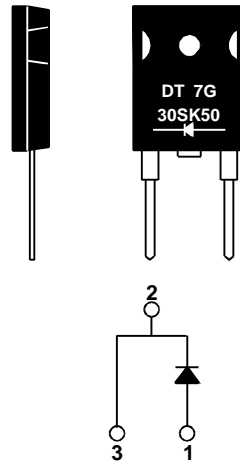

* Applies to Pins 1 and 3

Sym	Minimum		Maximum	
	in	mm	in	mm
A	0.19	4.82	0.205	5.2
A1	0.087	2.21	0.102	2.6
A2	0.075	1.9	0.085	2.16
B	0.045	1.14	0.055	1.4
B1	0.022	0.56	0.032	0.81
B2	0.079	2.01	0.094	2.39
B3	0.116	2.95	0.126	3.2
B4			0.215	5.46
C	0.602	15.29	0.625	15.88
D	0.776	19.7	0.799	20.3
D1	0.209	5.31	0.224	5.69
L	0.559	14.2	0.582	14.8
L1	0.146	3.71	0.189	4.8
L2			0.063	1.6
RO	0.209	5.3	0.224	5.7
phi P	0.13	3.3	0.145	3.7

TO-247AC (TO-3PAC)
SERIES 30SK40 - 30SK70

MAXIMUM RATINGS & ELECTRICAL CHARACTERISTICS

Ratings at 25 °C ambient temperature unless otherwise specified.
 Single phase, half wave, 60Hz, resistive or inductive load.
 For capacitive loads, derate current by 20%.

PARAMETER (TEST CONDITIONS)	SYMBOL	RATINGS					UNITS
		30SK30	30SK40	30SK50	30SK60	30SK70	
Series Number							
Maximum DC Blocking Voltage	V _{RM}						VOLTS
Maximum RMS Voltage	V _{RMS}	30	40	50	60	70	
Maximum Peak Recurrent Reverse Voltage	V _{RRM}						
Average Forward Rectified Current @ T _c = 100 °C	I _O	30					AMPS
Peak Forward Surge Current (8.3mS single half sine wave superimposed on rated load)	I _{FSM}	600		450			
Maximum Forward Voltage at 30 Amps DC	V _{FM}	0.55		0.65	0.85	VOLTS	
Maximum Average DC Reverse Current At Rated DC Blocking Voltage	I _{RM}	1 100					mA
Typical Thermal Resistance, Junction to Case (on heat sink)	R _{θJC}	1.3					°C/W
Operating and Storage Temperature Range	T _J , T _{STG}	-65 to +150					°C

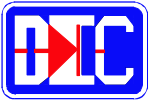

30 AMP SCHOTTKY BARRIER RECTIFIERS

RATING & CHARACTERISTIC CURVES FOR SERIES 30SK40 - 30SK70

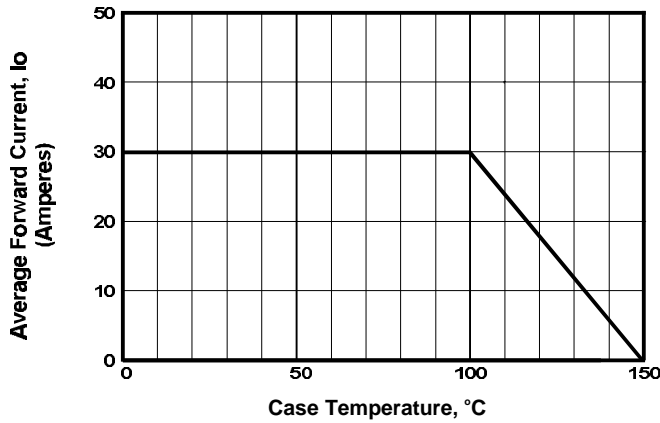

FIGURE 1. FORWARD CURRENT DERATING CURVE

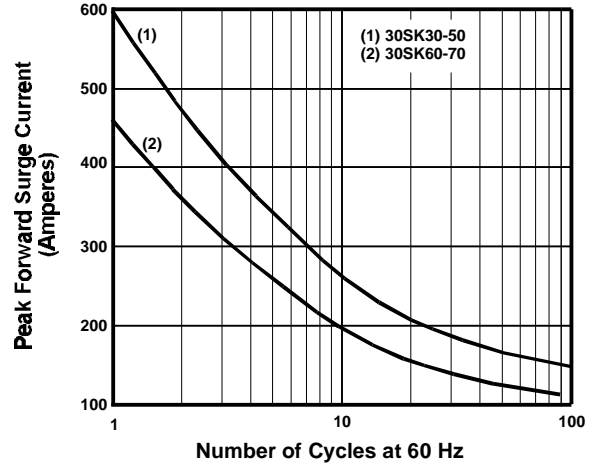

FIGURE 2. MAXIMUM NON-REPETITIVE SURGE CURRENT

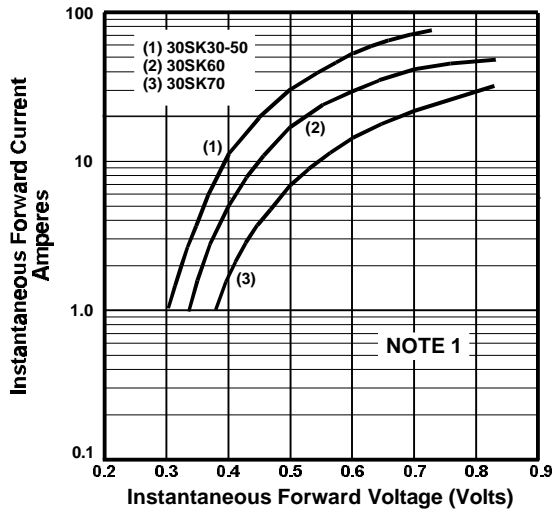

FIGURE 3. TYPICAL FORWARD CHARACTERISTICS

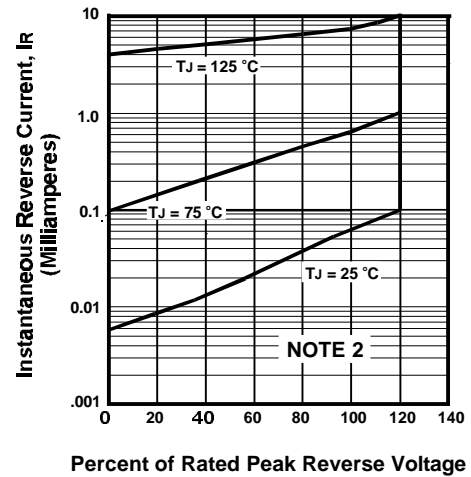

FIGURE 4. TYPICAL REVERSE CHARACTERISTICS

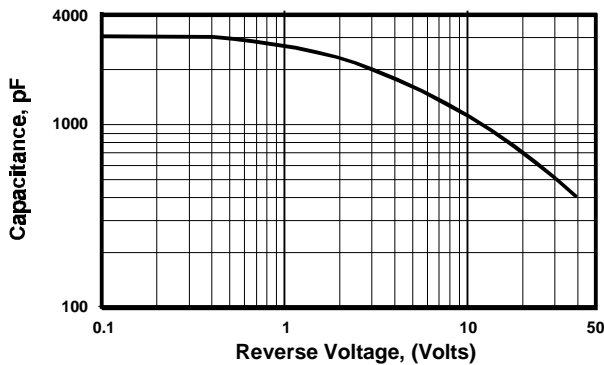

FIGURE 5. TYPICAL JUNCTION CAPACITANCE

NOTES

- (1) $T_J = 25\text{ }^\circ\text{C}$, Pulse Width = 300 μSec , 2.0% Duty Cycle
- (2) $T_J = 25\text{ }^\circ\text{C}$, $f = 1.0\text{ MHz}$, $V_{SIG} = 50\text{ mV P-P}$

SECTION B

DUAL DIODE

SCHOTTKY

RECTIFIERS

3 PIN TO-220AB AND TO-247AB PACKAGES

12 TO 60 AMPERES

30 TO 100 VOLTS

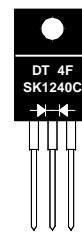

TO - 220AB

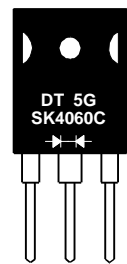

TO - 247AB

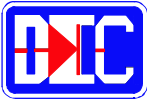

12 AMP SCHOTTKY BARRIER RECTIFIERS

FEATURES

- Low switching noise
- Low forward voltage drop
- Low thermal resistance
- High switching capability
- High surge capability
- High reliability

MECHANICAL DATA

- Case: TO-220 molded plastic (Fully Insulated) (U/L Flammability Rating 94V-0)
- Terminals: Rectangular pins w/ standoff
- Solderability: Per MIL-STD 202 Method 208 guaranteed
- Polarity: Diode depicted on product
- Mounting Position: Any
- Weight: 0.06 Ounces (1.75 Grams)

MECHANICAL SPECIFICATION

ACTUAL SIZE OF TO-220AB PACKAGE

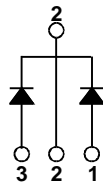
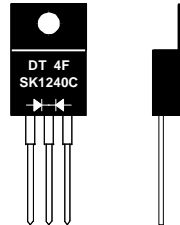

FULLY INSULATED PACKAGE

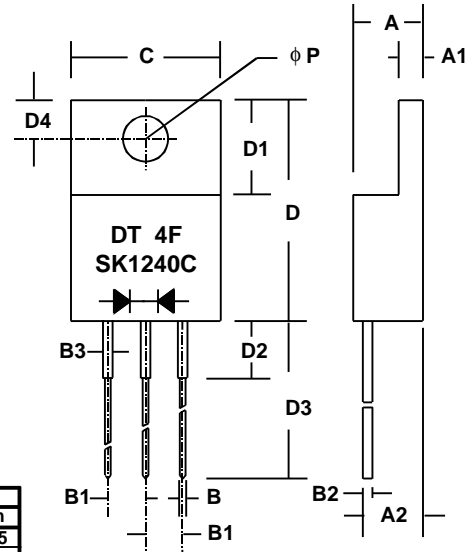

Sym	Minimum		Maximum	
	in	mm	in	mm
A			0.187	4.75
A1	0.055*	1.4*		
A2	0.14*	3.56*		
B	0.035	0.9	0.043	1.1
B1	0.09	2.3	0.102	2.6
B2	0.028*	0.66*		
B3	0.051*	1.3*		
C			0.410	10.4
D	0.59	15.0	0.61	15.5
D1	0.25*	6.4*		
D2			0.16	4.0
D3	0.53	13.5	0.57	14.8
D4	0.108*	2.75*		
phi P	0.141*	3.58*		

* These dimensions are "Typicals".

ITO-220AB

SERIES SK1240C - SK12100C

MAXIMUM RATINGS & ELECTRICAL CHARACTERISTICS

Ratings at 25 °C ambient temperature unless otherwise specified.
 Single phase, half wave, 60Hz, resistive or inductive load.
 For capacitive loads, derate current by 20%.

PARAMETER (TEST CONDITIONS)	SYMBOL	RATINGS					UNITS
		SK 1240C	SK 1250C	SK 1260C	SK 1270C	SK 12100C	
Series Number							
Maximum DC Blocking Voltage	V _{RM}						VOLTS
Maximum RMS Voltage	V _{RMS}	40	50	60	70	100	
Maximum Peak Recurrent Reverse Voltage	V _{RRM}						
Average Forward Rectified Current @ T _c = 100 °C	I _o	12					AMPS
Peak Forward Surge Current (8.3ms single half sine wave superimposed on rated load)	I _{FSM}	120					
Maximum Forward Voltage Drop (per diode) at 6 Amps DC	V _{FM}	0.55		0.65		0.85	VOLTS
Maximum Average DC Reverse Current At Rated DC Blocking Voltage @ T _J = 25 °C @ T _J = 100 °C	I _{RM}	0.5 50			0.2 10		mA
Typical Thermal Resistance, Junction to Case (on heat sink)	R _{θJC}	2.5					°C/W
Junction Operating Temperature Range	T _J	-65 to +150					°C
Storage Temperature Range	T _{STG}	-65 to +175					

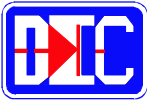

12 AMP SCHOTTKY BARRIER RECTIFIERS

RATING & CHARACTERISTIC CURVES FOR SERIES SK1240C - SK12100C

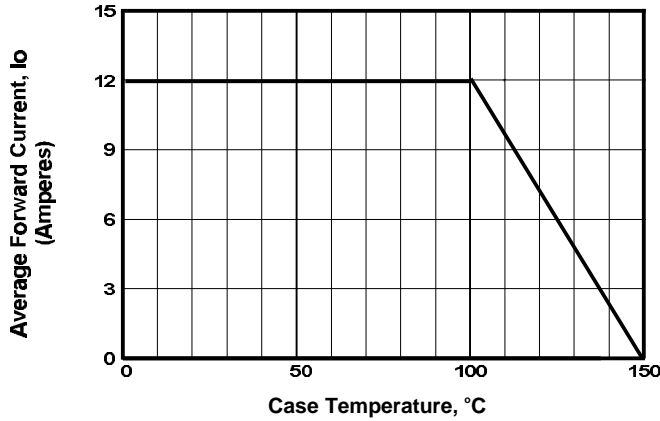

FIGURE 1. FORWARD CURRENT DERATING CURVE

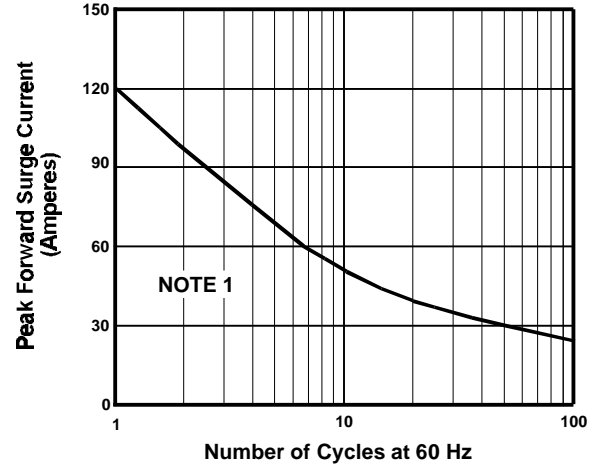

FIGURE 2. MAXIMUM NON-REPETITIVE SURGE CURRENT

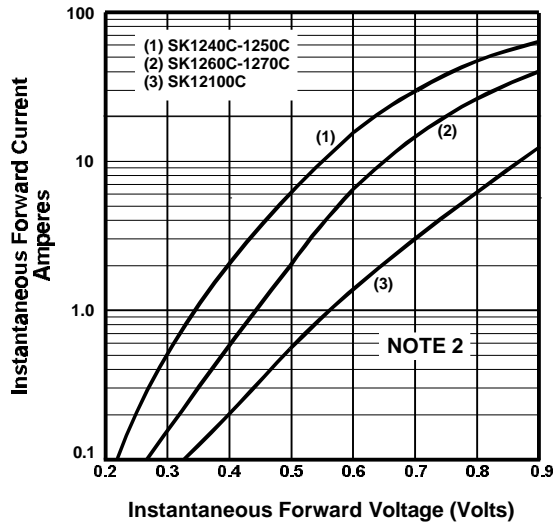

FIGURE 3. TYPICAL FORWARD CHARACTERISTICS

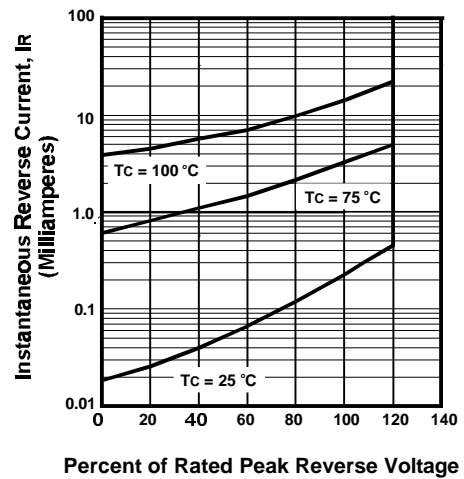

FIGURE 4. TYPICAL REVERSE CHARACTERISTICS

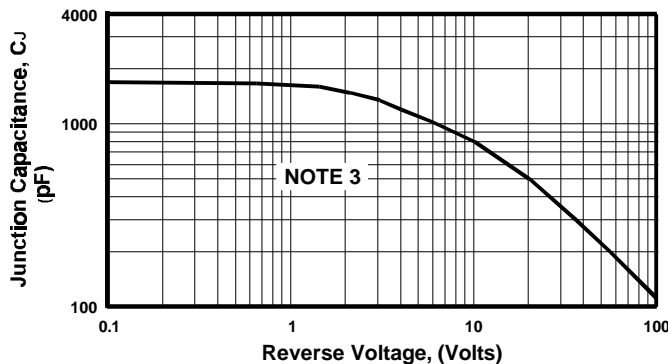
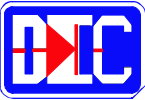

FIGURE 5. TYPICAL JUNCTION CAPACITANCE

NOTES

- (1) JEDEC Method, 8.3 mSec. Single Half Sine Wave
- (2) T_J = 25 °C, Pulse Width = 300 μSec, 2.0% Duty Cycle
- (3) T_c = 25 °C, f = 1.0 MHz, V_{SIG} = 50 mV P-P



16 AMP SCHOTTKY BARRIER RECTIFIERS

FEATURES

- Low switching noise
- Low forward voltage drop
- Low thermal resistance
- High switching capability
- High surge capability
- High reliability

MECHANICAL DATA

- Case: TO-220 molded plastic (Fully Insulated) (U/L Flammability Rating 94V-0)
- Terminals: Rectangular pins w/ standoff
- Solderability: Per MIL-STD 202 Method 208 guaranteed
- Polarity: Diode depicted on product
- Mounting Position: Any
- Weight: 0.06 Ounces (1.75 Grams)

MECHANICAL SPECIFICATION

ACTUAL SIZE OF TO-220AB PACKAGE

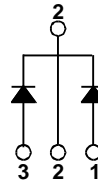
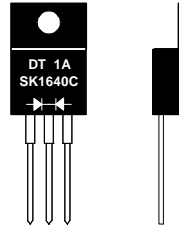

Sym	Minimum		Maximum	
	in	mm	in	mm
A			0.187	4.75
A1	0.055*	1.4*		
A2	0.14*	3.56*		
B	0.035	0.9	0.043	1.1
B1	0.09	2.3	0.102	2.6
B2	0.028*	0.66*		
B3	0.051*	1.3*		
C			0.410	10.4
D	0.59	15.0	0.61	15.5
D1	0.25*	6.4*		
D2			0.16	4.0
D3	0.53	13.5	0.57	14.8
D4	0.108*	2.75*		
φP	0.141*	3.58*		

* These dimensions are "Typicals".

FULLY INSULATED PACKAGE

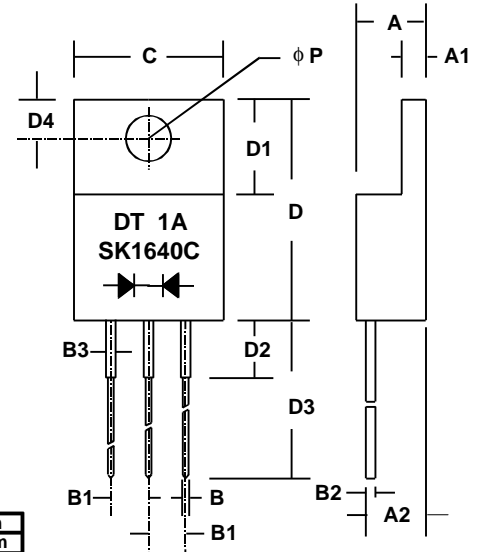

ITO-220AB

SERIES SK1640C - SK16100C

MAXIMUM RATINGS & ELECTRICAL CHARACTERISTICS

Ratings at 25 °C ambient temperature unless otherwise specified.
 Single phase, half wave, 60Hz, resistive or inductive load.
 For capacitive loads, derate current by 20%.

PARAMETER (TEST CONDITIONS)	SYMBOL	RATINGS					UNITS
		SK 1640C	SK 1650C	SK 1660C	SK 1670C	SK 16100C	
Series Number							
Maximum DC Blocking Voltage	V _{RM}	40	50	60	70	100	VOLTS
Maximum RMS Voltage	V _{RMS}						
Maximum Peak Recurrent Reverse Voltage	V _{RRM}						
Average Forward Rectified Current @ T _c = 110 °C	I _o	16					AMPS
Peak Forward Surge Current (8.3ms single half sine wave superimposed on rated load)	I _{FSM}	160					
Maximum Forward Voltage Drop (per diode) at 8 Amps DC	V _{FM}	0.55		0.65		0.85	VOLTS
Maximum Average DC Reverse Current At Rated DC Blocking Voltage	I _{RM}	0.5 50			0.2 10		mA
Typical Thermal Resistance, Junction to Case (on heat sink)	R _{θJC}	1.5					°C/W
Junction Operating Temperature Range	T _J	-65 to +150					°C
Storage Temperature Range	T _{STG}	-65 to +175					

4.9758-0016

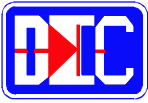

16 AMP SCHOTTKY BARRIER RECTIFIERS

RATING & CHARACTERISTIC CURVES FOR SERIES SK1640C - SK16100C

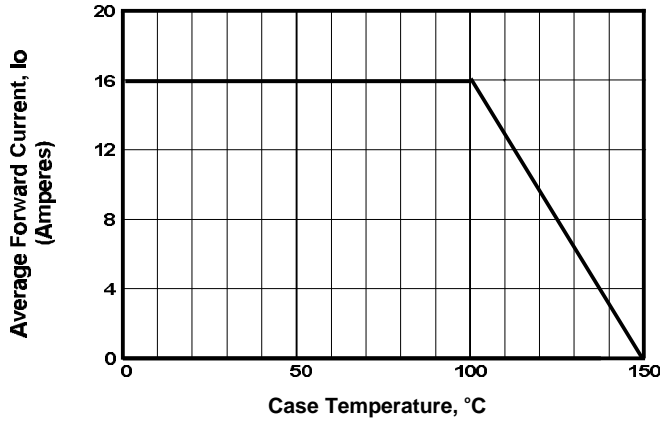

FIGURE 1. FORWARD CURRENT DERATING CURVE

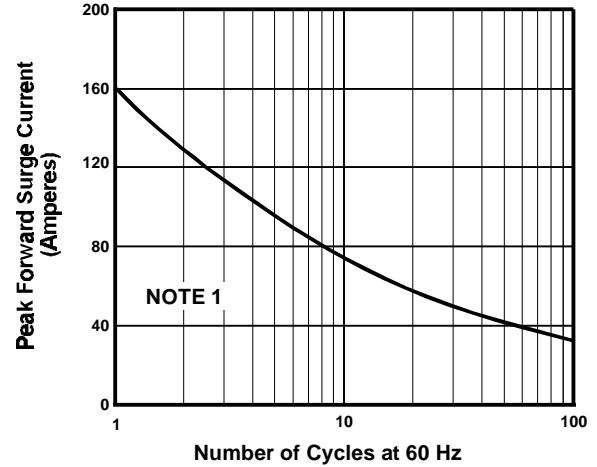

FIGURE 2. MAXIMUM NON-REPETITIVE SURGE CURRENT

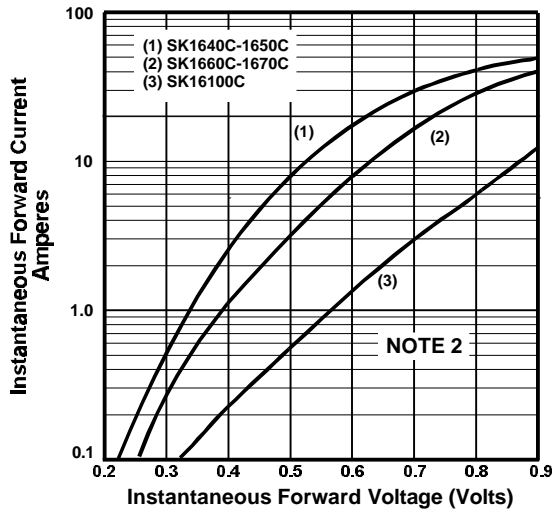

FIGURE 3. TYPICAL FORWARD CHARACTERISTICS

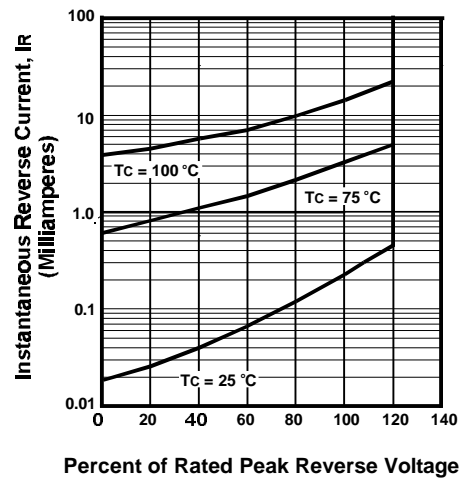

FIGURE 4. TYPICAL REVERSE CHARACTERISTICS

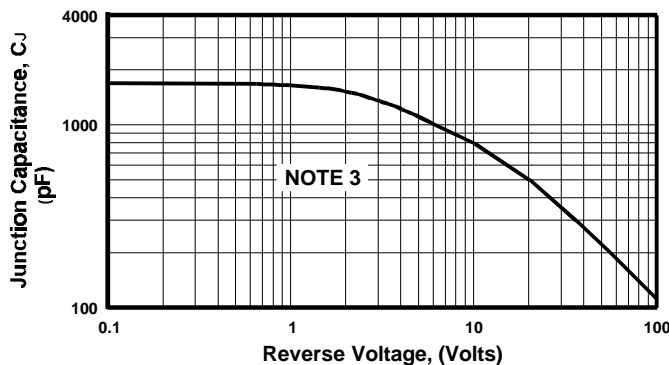
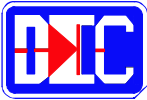

FIGURE 5. TYPICAL JUNCTION CAPACITANCE

NOTES

- (1) JEDEC Method, 8.3 mSec. Single Half Sine Wave
- (2) T_J = 25 °C, Pulse Width = 300 μSec, 2.0% Duty Cycle
- (3) T_c = 25 °C, f = 1.0 MHz, V_{SIG} = 50 mV P-P



24 AMP SCHOTTKY BARRIER RECTIFIERS

FEATURES

- Low switching noise
- Low forward voltage drop
- Low thermal resistance
- High switching capability
- High surge capability
- High reliability

MECHANICAL DATA

- Case: TO-247 (TO-3P) molded plastic (U/L Flammability Rating 94V-0)
- Terminals: Rectangular pins w/ standoff
- Solderability: Per MIL-STD 202 Method 208 guaranteed
- Polarity: Diode depicted on product
- Mounting Position: Any
- Weight: 0.20 Ounces (5.5 Grams)

MECHANICAL SPECIFICATION

ACTUAL SIZE OF TO-247AB
(TO-3PAB) PACKAGE

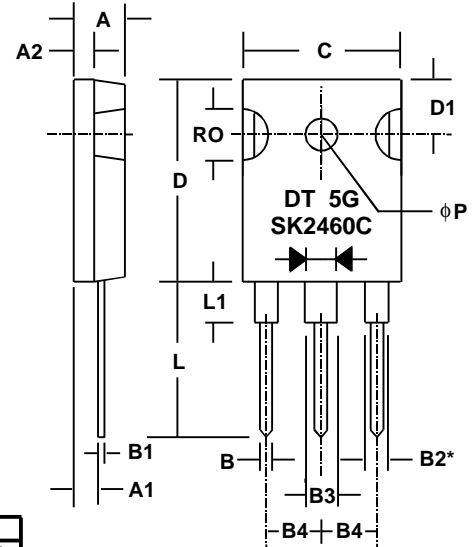
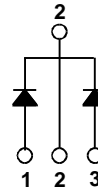
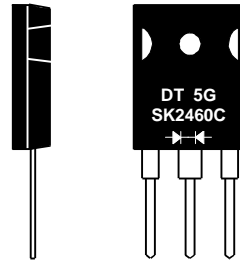

*Applies to Pins 1 and 3

Sym	Minimum		Maximum	
	in	mm	in	mm
A	0.19	4.82	0.205	5.2
A1	0.087	2.21	0.102	2.6
A2	0.075	1.9	0.085	2.16
B	0.045	1.14	0.055	1.4
B1	0.022	0.56	0.032	0.81
B2	0.079	2.01	0.094	2.39
B3	0.116	2.95	0.126	3.2
B4			0.215	5.46
C	0.602	15.29	0.625	15.88
D	0.776	19.7	0.799	20.3
D1	0.209	5.31	0.224	5.69
L	0.559	14.2	0.582	14.8
L1	0.146	3.71	0.189	4.8
RO	0.209	5.3	0.224	5.7
phi P	0.13	3.3	0.145	3.7

TO-247AB (TO-3PAB)

SERIES SK2440C - SK24100C

MAXIMUM RATINGS & ELECTRICAL CHARACTERISTICS

Ratings at 25 °C ambient temperature unless otherwise specified.
 Single phase, half wave, 60Hz, resistive or inductive load.
 For capacitive loads, derate current by 20%.

PARAMETER (TEST CONDITIONS)	SYMBOL	RATINGS					UNITS
		SK 2440C	SK 2450C	SK 2460C	SK 2470C	SK 24100C	
Series Number							
Maximum DC Blocking Voltage	V _{RM}	40	50	60	70	100	VOLTS
Maximum RMS Voltage	V _{RMS}						
Maximum Peak Recurrent Reverse Voltage	V _{RRM}						
Average Forward Rectified Current @ T _c = 100 °C	I _O	24					AMPS
Peak Forward Surge Current (8.3mS single half sine wave superimposed on rated load)	I _{FSM}	200					
Maximum Forward Voltage Drop (per diode) at 12 Amps DC	V _{FM}	0.55		0.65		0.85	VOLTS
Maximum Average DC Reverse Current At Rated DC Blocking Voltage	I _{RM}	0.5 100			0.2 15		mA
Typical Thermal Resistance, Junction to Case (on heat sink)	R _{θJC}	1.5					°C/W
Junction Operating Temperature Range	T _J	-65 to +150					°C
Storage Temperature Range	T _{STG}	-65 to +175					

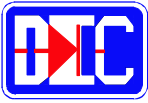

24 AMP SCHOTTKY BARRIER RECTIFIERS

RATING & CHARACTERISTIC CURVES FOR SERIES SK2440C - SK24100C

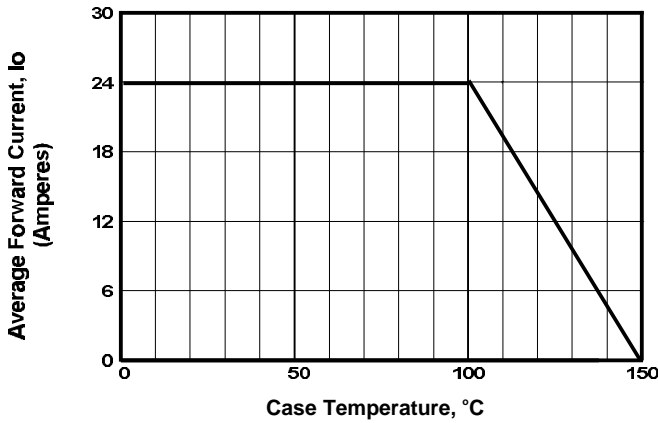

FIGURE 1. FORWARD CURRENT DERATING CURVE

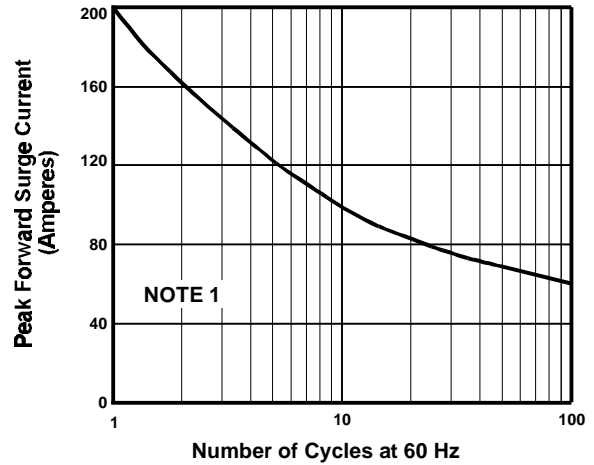

FIGURE 2. MAXIMUM NON-REPETITIVE SURGE CURRENT

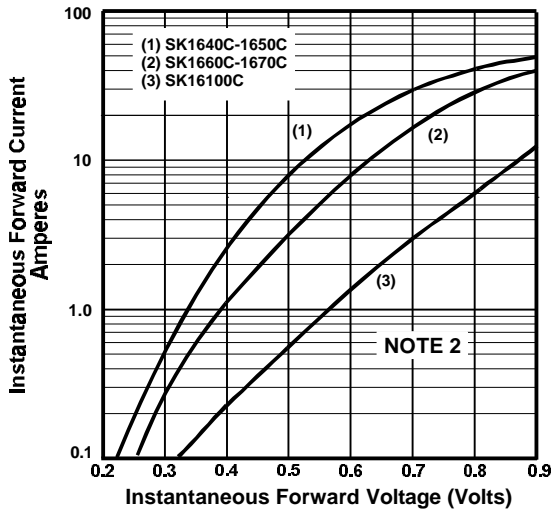

FIGURE 3. TYPICAL FORWARD CHARACTERISTICS

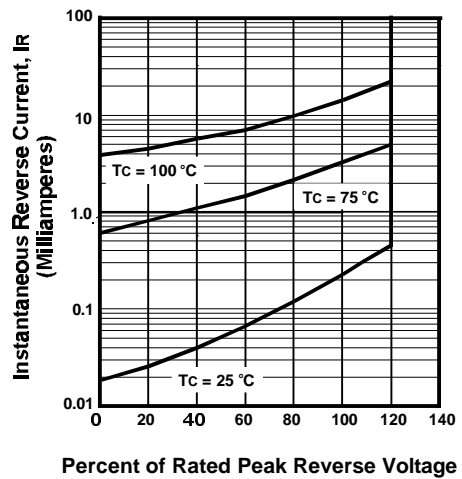

FIGURE 4. TYPICAL REVERSE CHARACTERISTICS

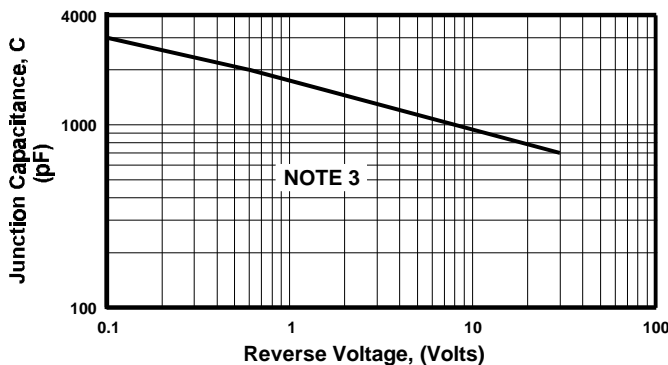

FIGURE 5. TYPICAL JUNCTION CAPACITANCE

NOTES

- (1) JEDEC Method, 8.3 mSec. Single Half Sine Wave
- (2) $T_J = 25^\circ\text{C}$, Pulse Width = 300 μSec , 2.0% Duty Cycle
- (3) $T_c = 25^\circ\text{C}$, $f = 1.0\text{ MHz}$, $V_{SIG} = 50\text{ mV P-P}$



30 AMP SCHOTTKY BARRIER RECTIFIERS

FEATURES

- Low switching noise
- Low forward voltage drop
- Low thermal resistance
- High switching capability
- High surge capability
- High reliability

MECHANICAL DATA

- Case: TO-247 (TO-3P) molded plastic (U/L Flammability Rating 94V-0)
- Terminals: Rectangular pins w/ standoff
- Solderability: Per MIL-STD 202 Method 208 guaranteed
- Polarity: Diode depicted on product
- Mounting Position: Any
- Weight: 0.20 Ounces (5.5 Grams)

MECHANICAL SPECIFICATION

ACTUAL SIZE OF TO-247AB
(TO-3PAB) PACKAGE

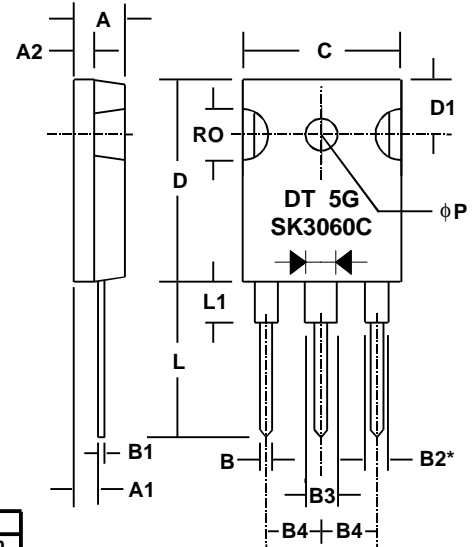
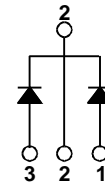
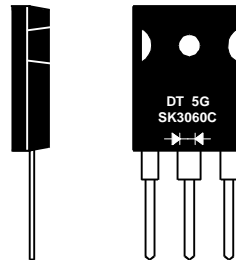

*Applies to Pins 1 and 3

Sym	Minimum		Maximum	
	in	mm	in	mm
A	0.19	4.82	0.205	5.2
A1	0.087	2.21	0.102	2.6
A2	0.075	1.9	0.085	2.16
B	0.045	1.14	0.055	1.4
B1	0.022	0.56	0.032	0.81
B2	0.079	2.01	0.094	2.39
B3	0.116	2.95	0.126	3.2
B4			0.215	5.46
C	0.602	15.29	0.625	15.88
D	0.776	19.7	0.799	20.3
D1	0.209	5.31	0.224	5.69
L	0.559	14.2	0.582	14.8
L1	0.146	3.71	0.189	4.8
RO	0.209	5.3	0.224	5.7
phi P	0.13	3.3	0.145	3.7

TO-247AB (TO-3PAB)

SERIES SK3040C - SK30100C

MAXIMUM RATINGS & ELECTRICAL CHARACTERISTICS

Ratings at 25 °C ambient temperature unless otherwise specified.
 Single phase, half wave, 60Hz, resistive or inductive load.
 For capacitive loads, derate current by 20%.

PARAMETER (TEST CONDITIONS)	SYMBOL	RATINGS					UNITS
		SK 3040C	SK 3050C	SK 3060C	SK 3070C	SK 30100C	
Series Number							
Maximum DC Blocking Voltage	V _{RM}	40	50	60	70	100	VOLTS
Maximum RMS Voltage	V _{RMS}						
Maximum Peak Recurrent Reverse Voltage	V _{RRM}						
Average Forward Rectified Current @ T _c = 90 °C	I _o	30					AMPS
Peak Forward Surge Current (8.3mS single half sine wave superimposed on rated load)	I _{FSM}	200					
Maximum Forward Voltage Drop (per diode) at 15 Amps DC	V _{FM}	0.57		0.65		0.85	VOLTS
Maximum Average DC Reverse Current At Rated DC Blocking Voltage	I _{RM}	0.5 100			0.2 15		mA
Typical Thermal Resistance, Junction to Case (on heat sink)	R _{θJC}	1.2					°C/W
Junction Operating Temperature Range	T _J	-65 to +150					°C
Storage Temperature Range	T _{STG}	-65 to +175					

4475b000

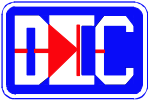

30 AMP SCHOTTKY BARRIER RECTIFIERS

RATING & CHARACTERISTIC CURVES FOR SK3040C - SK30100C SERIES

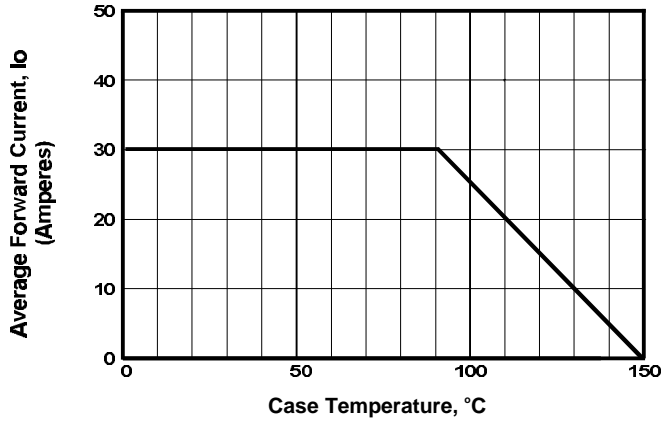

FIGURE 1. FORWARD CURRENT DERATING CURVE

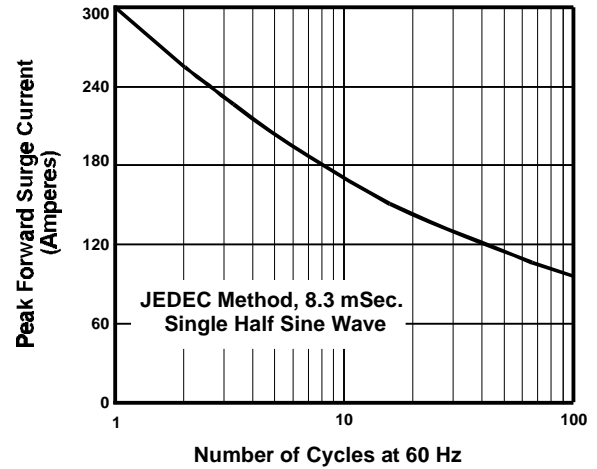

FIGURE 2. MAXIMUM NON-REPETITIVE SURGE CURRENT

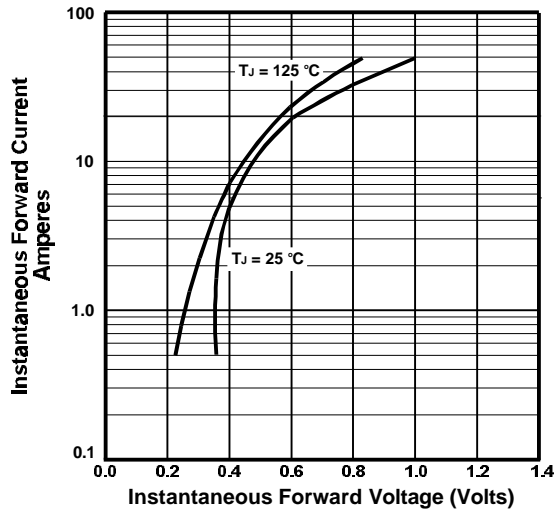

FIGURE 3. TYPICAL FORWARD CHARACTERISTICS

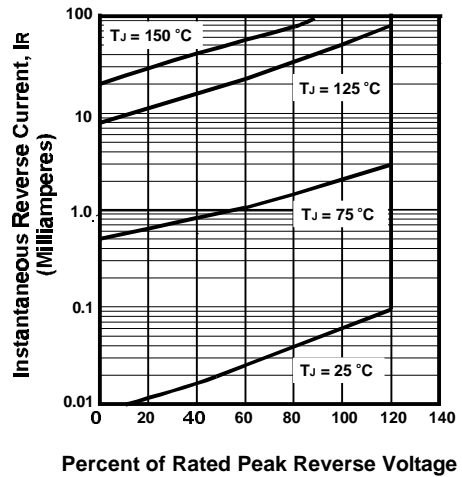

FIGURE 4. TYPICAL REVERSE CHARACTERISTICS

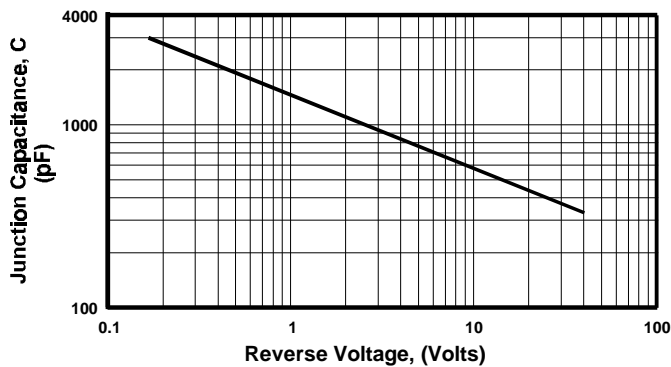

FIGURE 5. TYPICAL JUNCTION CAPACITANCE

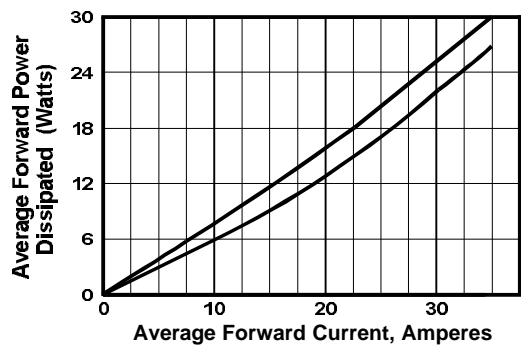
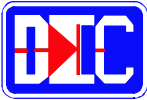

FIGURE 6. FORWARD POWER DISSIPATION



40 AMP SCHOTTKY BARRIER RECTIFIERS

FEATURES

- Low switching noise
- Low forward voltage drop
- Low thermal resistance
- High switching capability
- High surge capability
- High reliability

MECHANICAL DATA

- Case: TO-247 (TO-3P) molded plastic (U/L Flammability Rating 94V-0)
- Terminals: Rectangular pins w/ standoff
- Solderability: Per MIL-STD 202 Method 208 guaranteed
- Polarity: Diode depicted on product
- Mounting Position: Any
- Weight: 0.20 Ounces (5.5 Grams)

MECHANICAL SPECIFICATION

ACTUAL SIZE OF TO-247AB
(TO-3PAB) PACKAGE

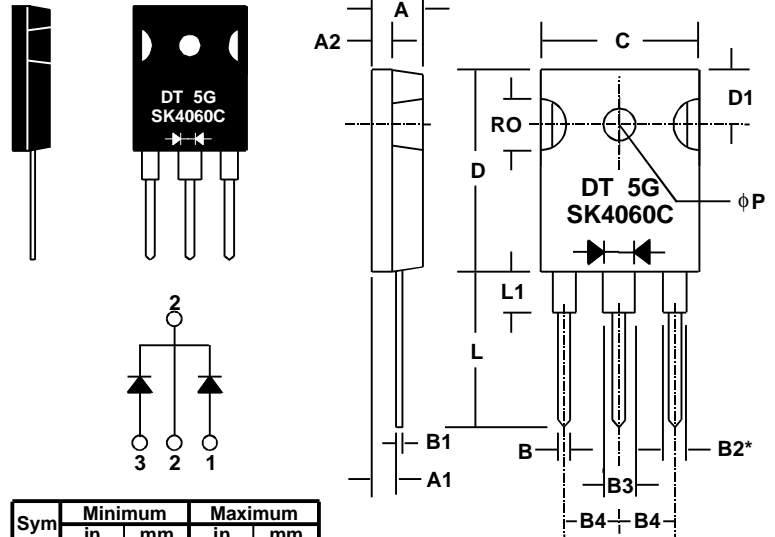

Sym	Minimum		Maximum	
	in	mm	in	mm
A	0.19	4.82	0.205	5.2
A1	0.087	2.21	0.102	2.6
A2	0.075	1.9	0.085	2.16
B	0.045	1.14	0.055	1.4
B1	0.022	0.56	0.032	0.81
B2	0.079	2.01	0.094	2.39
B3	0.116	2.95	0.126	3.2
B4			0.215	5.46
C	0.602	15.29	0.625	15.88
D	0.776	19.7	0.799	20.3
D1	0.209	5.31	0.224	5.69
L	0.559	14.2	0.582	14.8
L1	0.146	3.71	0.189	4.8
RO	0.209	5.3	0.224	5.7
φP	0.13	3.3	0.145	3.7

*Applies to Pins 1 and 3

TO-247AB (TO-3PAB)

SERIES SK4040C - SK40100C

MAXIMUM RATINGS & ELECTRICAL CHARACTERISTICS

Ratings at 25 °C ambient temperature unless otherwise specified.
 Single phase, half wave, 60Hz, resistive or inductive load.
 For capacitive loads, derate current by 20%.

PARAMETER (TEST CONDITIONS)	SYMBOL	RATINGS					UNITS
		SK 4040C	SK 4050C	SK 4060C	SK 4070C	SK 40100C	
Series Number							
Maximum DC Blocking Voltage	V _{RM}	40	50	60	70	100	VOLTS
Maximum RMS Voltage	V _{RMS}						
Maximum Peak Recurrent Reverse Voltage	V _{RRM}						
Average Forward Rectified Current @ T _c = 85 °C	I _o	40					AMPS
Peak Forward Surge Current (8.3mS single half sine wave superimposed on rated load)	I _{FSM}	200					
Maximum Forward Voltage Drop (per diode) at 20 Amps	V _{FM}	0.6		0.7		0.92	VOLTS
Maximum Average DC Reverse Current At Rated DC Blocking Voltage	I _{RM}	2.0			2.0		mA
		100			50		
Typical Thermal Resistance, Junction to Case (on heat sink)	R _{θJC}	1.2					°C/W
Junction Operating Temperature Range	T _J	-65 to +150					°C
Storage Temperature Range	T _{STG}	-65 to +175					

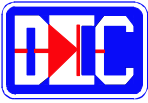

40 AMP SCHOTTKY BARRIER RECTIFIERS

RATING & CHARACTERISTIC CURVES FOR SK4040C - SK40100C SERIES

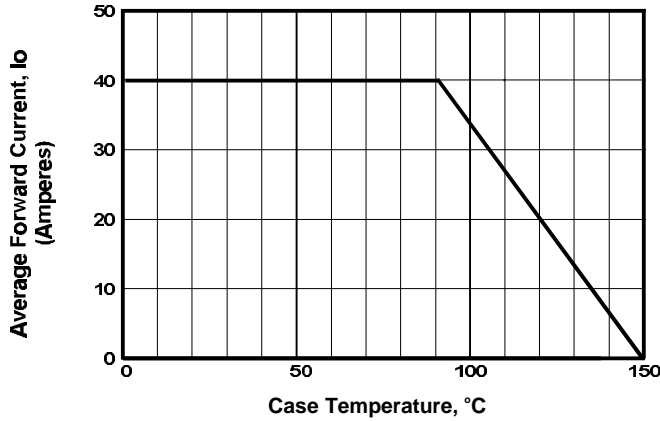

FIGURE 1. FORWARD CURRENT DERATING CURVE

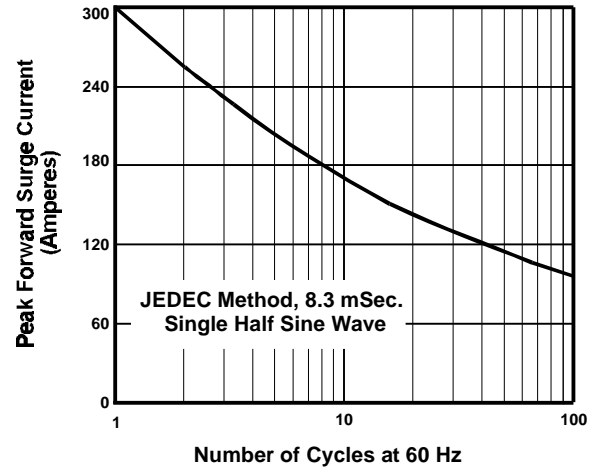

FIGURE 2. MAXIMUM NON-REPETITIVE SURGE CURRENT

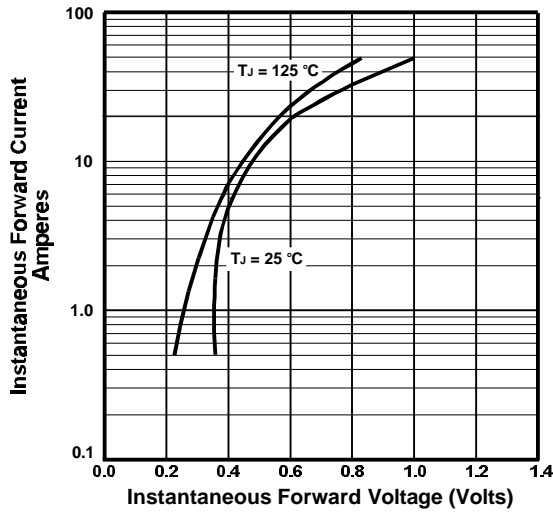

FIGURE 3. TYPICAL FORWARD CHARACTERISTICS

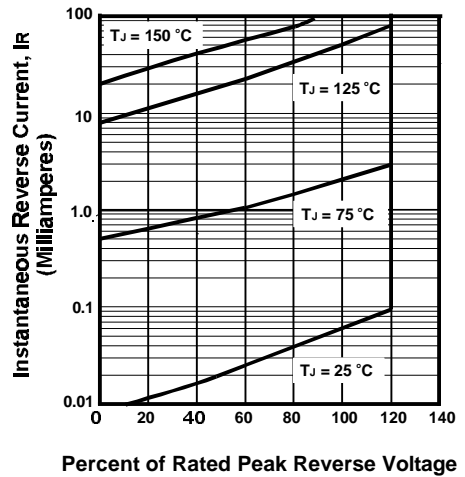

FIGURE 4. TYPICAL REVERSE CHARACTERISTICS

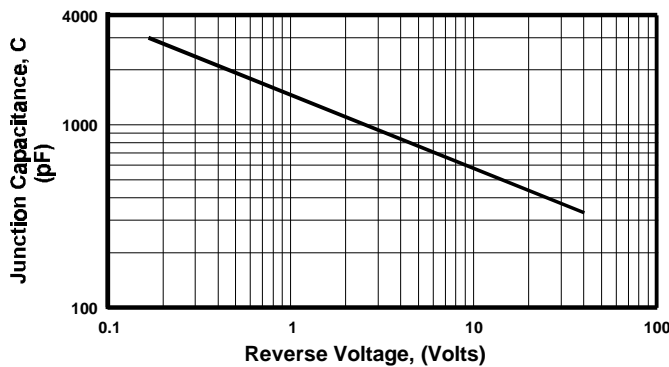

FIGURE 5. TYPICAL JUNCTION CAPACITANCE

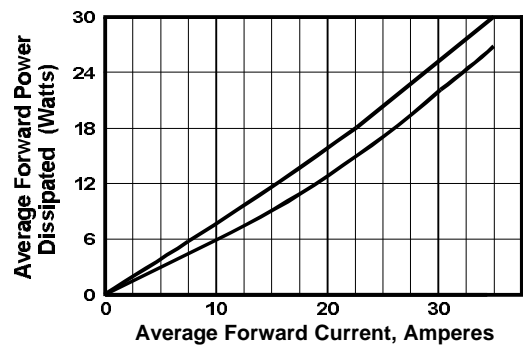
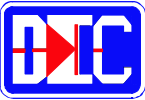

FIGURE 6. FORWARD POWER DISSIPATION



60 AMP SCHOTTKY BARRIER RECTIFIERS

FEATURES

- Low switching noise
- Low forward voltage drop
- Low thermal resistance
- High switching capability
- High surge capability
- High reliability

MECHANICAL DATA

- Case: TO-247 (TO-3P) molded plastic (U/L Flammability Rating 94V-0)
- Terminals: Rectangular pins w/ standoff
- Solderability: Per MIL-STD 202 Method 208 guaranteed
- Polarity: Diode depicted on product
- Mounting Position: Any
- Weight: 0.20 Ounces (5.5 Grams)

MECHANICAL SPECIFICATION

ACTUAL SIZE OF TO-247AB
(TO-3PAB) PACKAGE

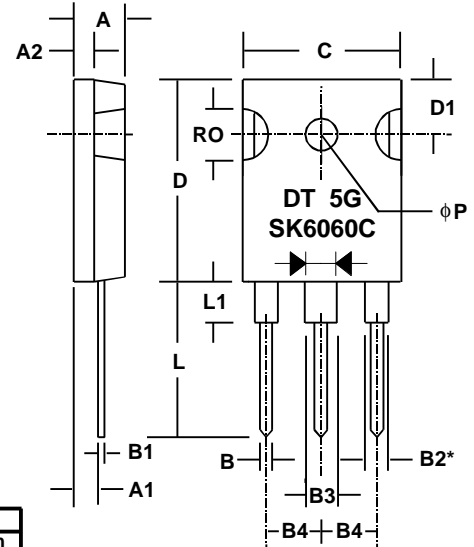
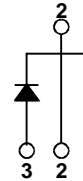
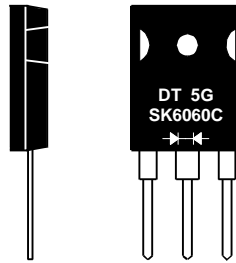

*Applies to Pins 1 and 3

Sym	Minimum		Maximum	
	in	mm	in	mm
A	0.19	4.82	0.205	5.2
A1	0.087	2.21	0.102	2.6
A2	0.075	1.9	0.085	2.16
B	0.045	1.14	0.055	1.4
B1	0.022	0.56	0.032	0.81
B2	0.079	2.01	0.094	2.39
B3	0.116	2.95	0.126	3.2
B4			0.215	5.46
C	0.602	15.29	0.625	15.88
D	0.776	19.7	0.799	20.3
D1	0.209	5.31	0.224	5.69
L	0.559	14.2	0.582	14.8
L1	0.146	3.71	0.189	4.8
RO	0.209	5.3	0.224	5.7
phi P	0.13	3.3	0.145	3.7

TO-247AB (TO-3PAB)

SERIES SK6030C - SK6070C

MAXIMUM RATINGS & ELECTRICAL CHARACTERISTICS

Ratings at 25 °C ambient temperature unless otherwise specified.
 Single phase, half wave, 60Hz, resistive or inductive load.
 For capacitive loads, derate current by 20%.

PARAMETER (TEST CONDITIONS)	SYMBOL	RATINGS					UNITS
		SK 6030C	SK 6040C	SK 6050C	SK 6060C	SK 6070C	
Series Number							
Maximum DC Blocking Voltage	V _{RM}	30	40	50	60	70	VOLTS
Maximum RMS Voltage	V _{RMS}						
Maximum Peak Recurrent Reverse Voltage	V _{RRM}						
Average Forward Rectified Output Current @ T _c = 90 °C	I _o	60					AMPS
Peak Forward Surge Current (8.3mS single half sine wave superimposed on rated load)	I _{FSM}	600					
Maximum Forward Voltage Drop (per diode) at 30 Amps	V _{FM}	0.55		0.65		VOLTS	
Maximum Average DC Reverse Current At Rated DC Blocking Voltage	I _{RM}	5.0			200		mA
		@ T _J = 25 °C			@ T _J = 125 °C		
Typical Thermal Resistance, Junction to Case (on heat sink)	R _{θJC}	1.1					°C/W
Junction Operating Temperature Range	T _J	-65 to +150					°C
Storage Temperature Range	T _{STG}	-65 to +175					

4875b000

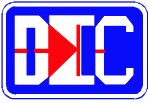

60 AMP SCHOTTKY BARRIER RECTIFIERS

RATING & CHARACTERISTIC CURVES FOR SK6030C - SK6070C SERIES

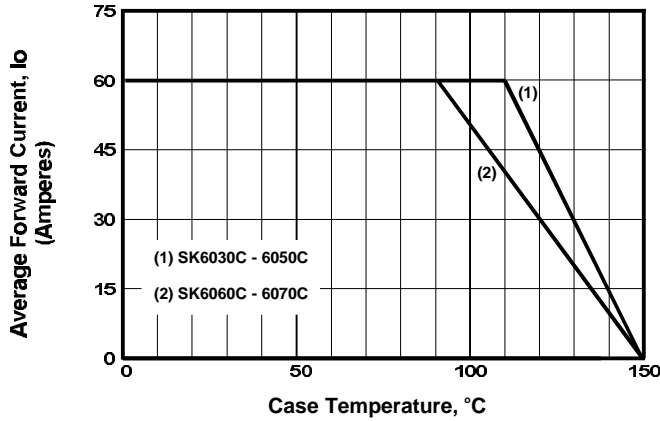

FIGURE 1. FORWARD CURRENT DERATING CURVE

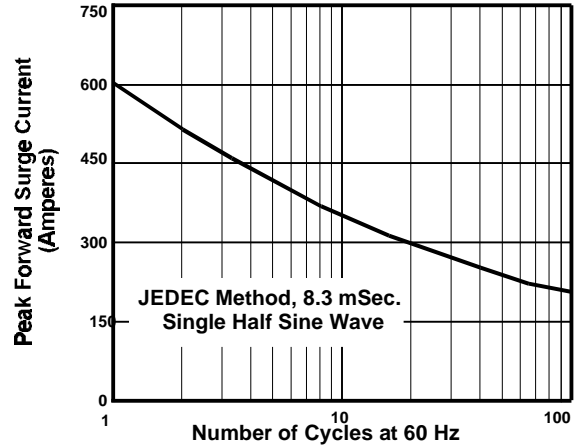

FIGURE 2. MAXIMUM NON-REPETITIVE SURGE CURRENT

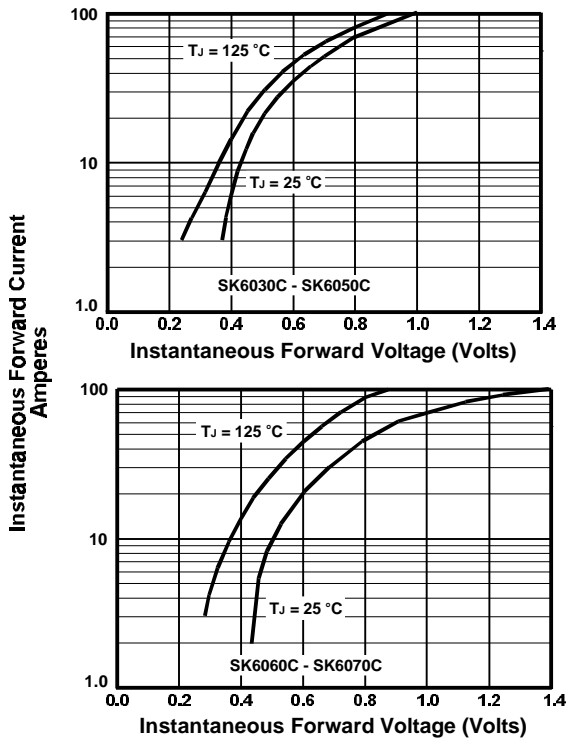

FIGURE 3. TYPICAL FORWARD CHARACTERISTICS

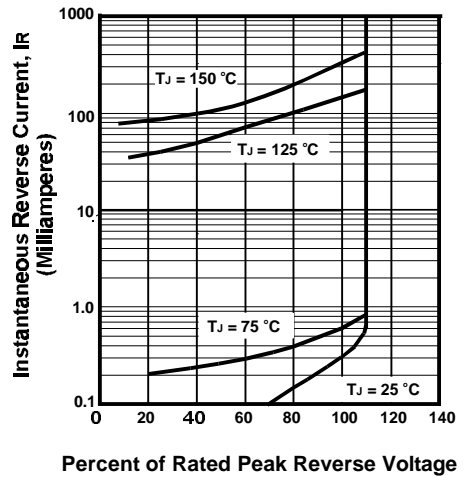

FIGURE 4. TYPICAL REVERSE CHARACTERISTICS

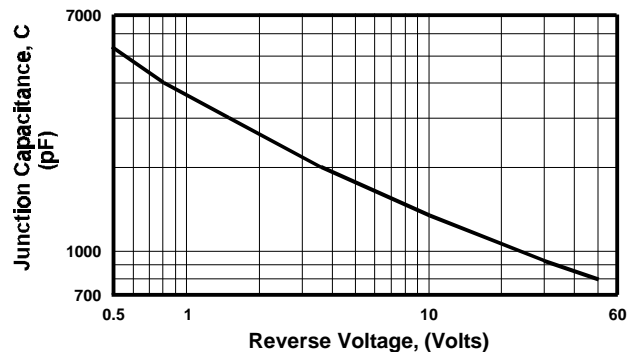

FIGURE 5. TYPICAL JUNCTION CAPACITANCE

SECTION C
SUPER EFFICIENT and
ULTRA FAST RECOVERY
DIODES
Single Diode Products

AXIAL LEAD DO-41, DO-27, AND G-6A PACKAGES

1 TO 6 AMPERES

50 TO 1000 VOLTS

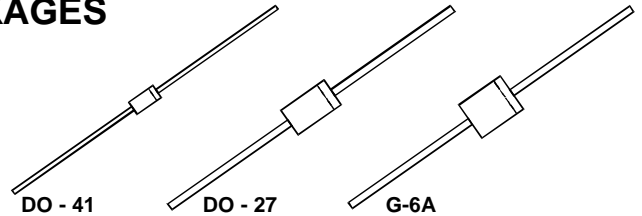

2 PIN TO-220AC PACKAGE

6 TO 15 AMPERES

50 TO 600 VOLTS



TO - 220AC

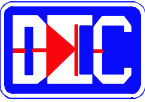

1 AMP SUPER-EFFICIENT RECTIFIERS

FEATURES

- PROPRIETARY **SOFT GLASS[®]** JUNCTION PASSIVATION FOR SUPERIOR RELIABILITY AND PERFORMANCE
- VOID FREE VACUUM DIE SOLDERING FOR MAXIMUM MECHANICAL STRENGTH AND HEAT DISSIPATION (Solder Voids: Typical $\leq 2\%$, Max. $\leq 10\%$ of Die Area)
- LOW SWITCHING NOISE
- LOW THERMAL RESISTANCE
- HIGH SWITCHING CAPABILITY
- LOW FORWARD VOLTAGE DROP

MECHANICAL DATA

- Case: JEDEC DO-41 molded plastic (U/L Flammability Rating 94V-0)
- Terminals: Plated axial leads
- Solderability: Per MIL-STD 202 Method 208 guaranteed
- Polarity: Color band denotes cathode
- Mounting Position: Any
- Weight: 0.013 Ounces (0.35 Grams)

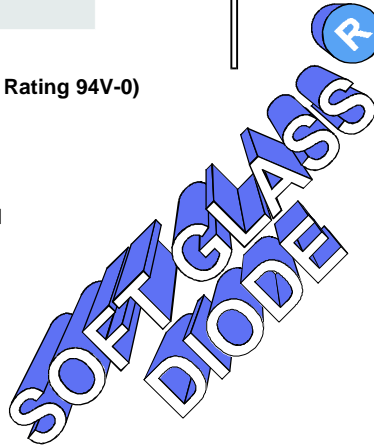

MECHANICAL SPECIFICATION

ACTUAL SIZE OF DO-41 PACKAGE

SERIES SPR11 - SPR14

DO - 41

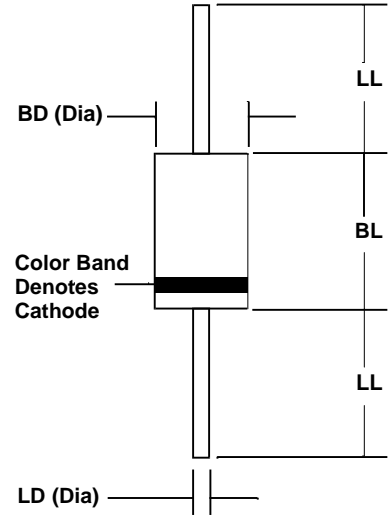

Sym	Minimum		Maximum	
	In	mm	In	mm
BL	0.160	4.1	0.205	5.2
BD	0.103	2.6	0.107	2.7
LL	1.00	25.4		
LD	0.028	0.71	0.034	0.86

MAXIMUM RATINGS & ELECTRICAL CHARACTERISTICS

Ratings at 25 °C ambient temperature unless otherwise specified.
 Single phase, half wave, 60Hz, resistive or inductive load.
 For capacitive loads, derate current by 20%.

PARAMETER (TEST CONDITIONS)	SYMBOL	RATINGS				UNITS
		SPR11	SPR12	SPR13	SPR14	
Series Number		SPR11	SPR12	SPR13	SPR14	
Maximum DC Blocking Voltage	V _{RM}	100	200	300	400	VOLTS
Maximum RMS Voltage	V _{RMS}	70	140	210	280	
Maximum Peak Recurrent Reverse Voltage	V _{RRM}	100	200	300	400	
Average Forward Rectified Current @ T _A = 55 °C	I _O	1				AMPS
Peak Forward Surge Current (8.3mS single half sine wave superimposed on rated load)	I _{FSM}	30				
Maximum Forward Voltage at 1 Amp DC	V _{FM}	0.95		1.25		VOLTS
Maximum Average DC Reverse Current At Rated DC Blocking Voltage @ T _c = 25 °C @ T _c = 100 °C	I _{RM}	2.0		50		μA
Typical Thermal Resistance, Junction to Ambient	R _{θJA}	50				°C/W
Typical Junction Capacitance (Note 1)	C _J	50				pF
Maximum Reverse Recovery Time (I _F =0.5A, I _R =1A, I _{RR} =0.25A)	T _{RR}	35				nSec
Junction Operating and Storage Temperature Range	T _J , T _{STG}	-65 to +150				°C

NOTES: (1) Measured at 1 MHz and an applied reverse voltage of 4 volts.

4.975221

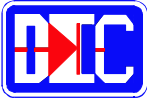

1 AMP SUPER EFFICIENT RECTIFIERS

RATING & CHARACTERISTIC CURVES FOR SERIES SPR11 - SPR14

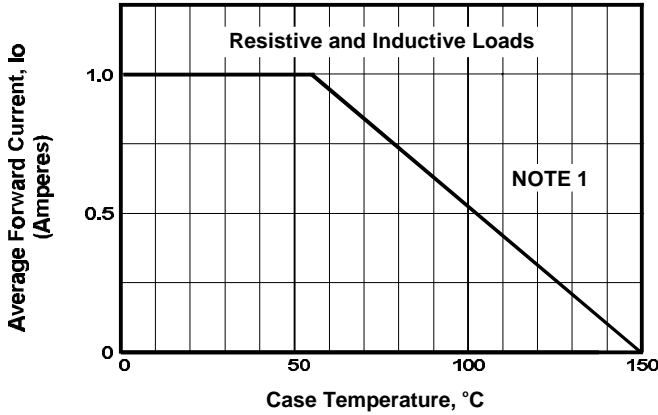

FIGURE 1. FORWARD CURRENT DERATING CURVE

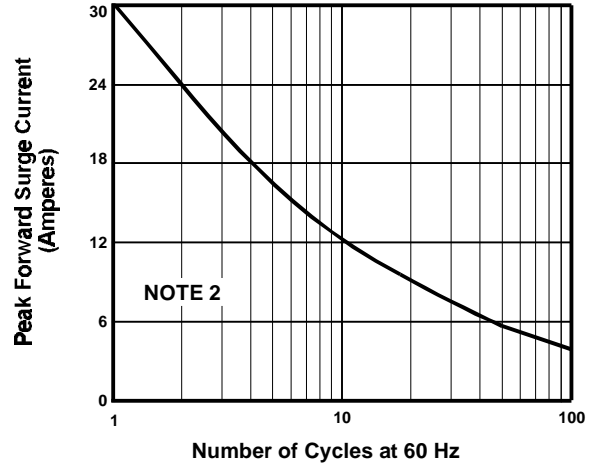

FIGURE 2. MAXIMUM NON-REPETITIVE SURGE CURRENT

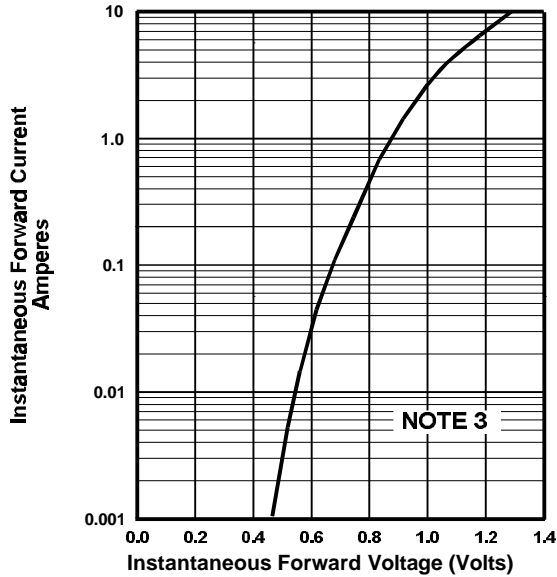

FIGURE 3. TYPICAL FORWARD CHARACTERISTICS

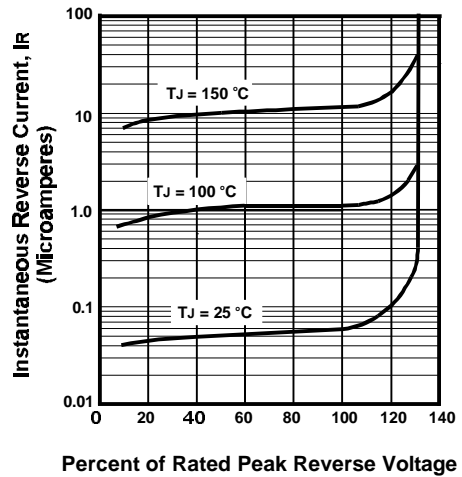

FIGURE 4. TYPICAL REVERSE CHARACTERISTICS

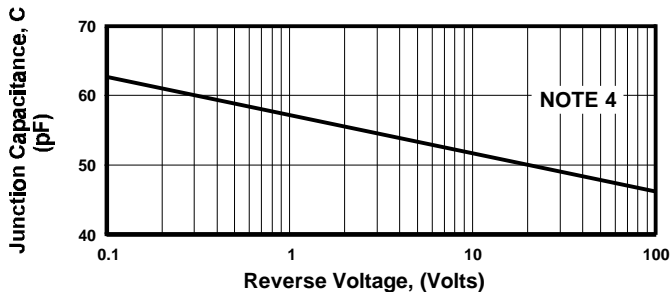
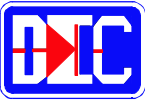

FIGURE 5. TYPICAL JUNCTION CAPACITANCE

NOTES

- (1) Single Phase, Half Wave, 60 Hz; Lead Length = 0.375" (9.5mm)
- (2) JEDEC Method, 8.3 mSec. Single Half Sine Wave
- (3) $T_J = 25^\circ\text{C}$, Pulse Width = 300 μSec , 1.0% Duty Cycle
- (4) $T_J = 25^\circ\text{C}$, $f = 1.0\text{ MHz}$, 2% Duty Cycle.



1 AMP ULTRAFAST RECOVERY DIODES

FEATURES

- PROPRIETARY **SOFT GLASS[®]** JUNCTION PASSIVATION FOR SUPERIOR RELIABILITY AND PERFORMANCE
- VOID FREE VACUUM DIE SOLDERING FOR MAXIMUM MECHANICAL STRENGTH AND HEAT DISSIPATION (Solder Voids: Typical $\leq 2\%$, Max. $\leq 10\%$ of Die Area)
- LOW SWITCHING NOISE
- LOW THERMAL RESISTANCE
- HIGH SWITCHING CAPABILITY
- LOW FORWARD VOLTAGE DROP

MECHANICAL DATA

- Case: JEDEC DO-41 molded plastic (U/L Flammability Rating 94V-0)
- Terminals: Plated axial leads
- Solderability: Per MIL-STD 202 Method 208 guaranteed
- Polarity: Color band denotes cathode
- Mounting Position: Any
- Weight: 0.013 Ounces (0.35 Grams)

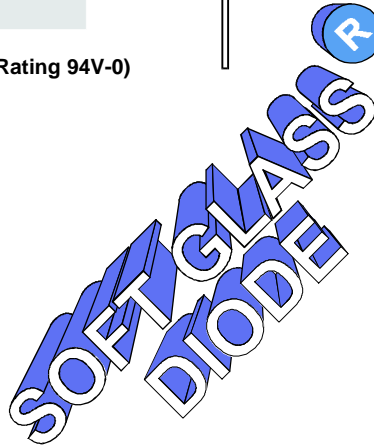

MECHANICAL SPECIFICATION

ACTUAL SIZE OF DO-41 PACKAGE

SERIES UFR100 - UFR110

DO - 41

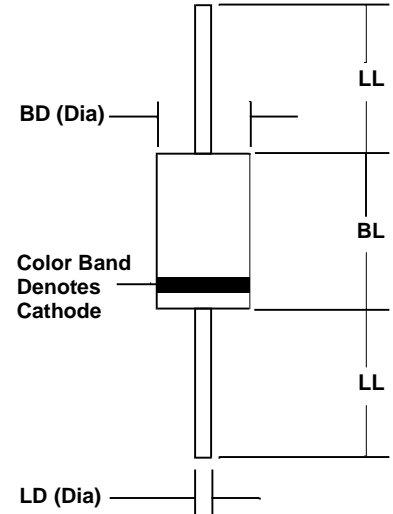

Sym	Minimum		Maximum	
	In	mm	In	mm
BL	0.160	4.1	0.205	5.2
BD	0.103	2.6	0.107	2.7
LL	1.00	25.4		
LD	0.028	0.71	0.034	0.86

MAXIMUM RATINGS & ELECTRICAL CHARACTERISTICS

Ratings at 25 °C ambient temperature unless otherwise specified.
 Single phase, half wave, 60Hz, resistive or inductive load.
 For capacitive loads, derate current by 20%.

PARAMETER (TEST CONDITIONS)	SYMBOL	RATINGS										UNITS
		UFR 100	UFR 101	UFR 102	UFR 103	UFR 104	UFR 105	UFR 106	UFR 108	UFR 110		
Series Number												
Maximum DC Blocking Voltage	VRM	50	100	200	300	400	500	600	800	1000		
Maximum RMS Voltage	VRMS	35	70	140	210	280	350	420	560	700	VOLTS	
Maximum Peak Recurrent Reverse Voltage	VRRM	50	100	200	300	400	500	600	800	1000		
Average Forward Rectified Current @ TA = 55 °C	IO	1										AMPS
Peak Forward Surge Current (8.3mS single half sine wave superimposed on rated load)	IFSM	35										
Maximum Forward Voltage at 1 Amp DC	VFM	1.25					1.7					VOLTS
Maximum Average DC Reverse Current @ Tc = 25° C	IRM	2.0										µA
At Rated DC Blocking Voltage @ Tc = 125° C		50										
Typical Thermal Resistance, Junction to Ambient	RθJA	50										°C/W
Typical Junction Capacitance (Note 1)	CJ	15										pF
Maximum Reverse Recovery Time (IF=0.5A, IR=1A, IRR=0.25A)	TRR	50					75					nSec
Junction Operating and Storage Temperature Range	TJ, TSTG	-65 to +150										°C

NOTES: (1) Measured at 1 MHz and an applied reverse voltage of 4 volts.

3.01 UFR100



1 AMP ULTRAFAST RECOVERY DIODES

RATING & CHARACTERISTIC CURVES FOR SERIES UFR100 - UFR110

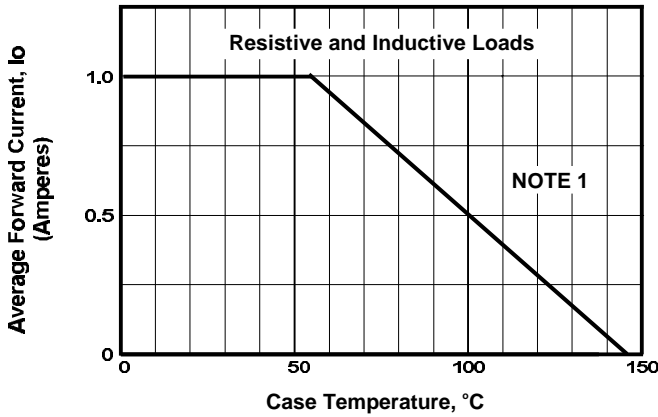

FIGURE 1. FORWARD CURRENT DERATING CURVE

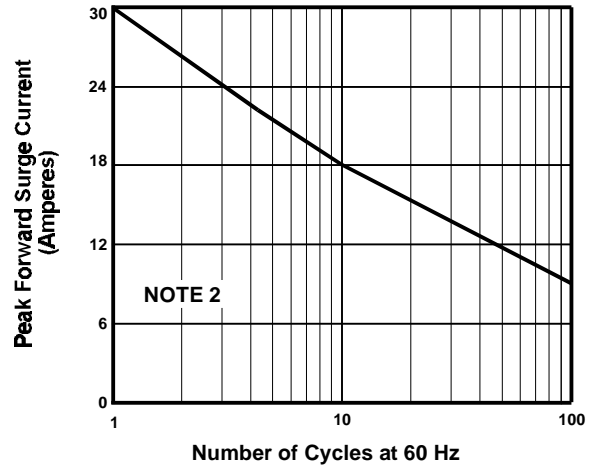

FIGURE 2. MAXIMUM NON-REPETITIVE SURGE CURRENT

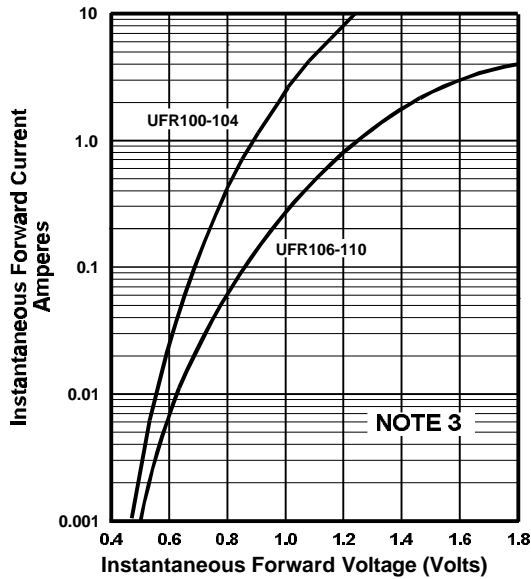

FIGURE 3. TYPICAL FORWARD CHARACTERISTICS

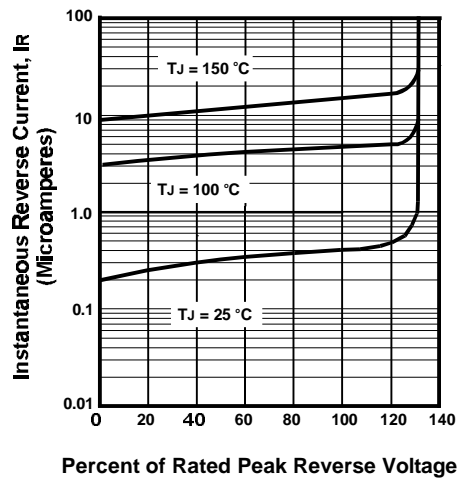

FIGURE 4. TYPICAL REVERSE CHARACTERISTICS

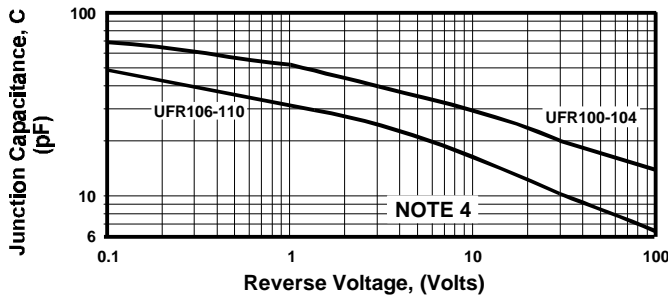
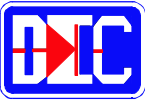

FIGURE 5. TYPICAL JUNCTION CAPACITANCE

NOTES

- (1) Single Phase, Half Wave, 60 Hz; Lead Length = 0.375" (9.5mm)
- (2) JEDEC Method, 8.3 mSec. Single Half Sine Wave
- (3) $T_J = 25^\circ\text{C}$, Pulse Width = 300 μSec , 1.0% Duty Cycle
- (4) $T_J = 25^\circ\text{C}$, $f = 1.0\text{ MHz}$, 2% Duty Cycle.



2 AMP SUPER-EFFICIENT RECTIFIERS/ULTRAFAST RECOVERY DIODES

FEATURES

- PROPRIETARY **SOFT GLASS[®]** JUNCTION PASSIVATION FOR SUPERIOR RELIABILITY AND PERFORMANCE
- VOID FREE VACUUM DIE SOLDERING FOR MAXIMUM MECHANICAL STRENGTH AND HEAT DISSIPATION (Solder Voids: Typical $\leq 2\%$, Max. $\leq 10\%$ of Die Area)
- LOW SWITCHING NOISE
- LOW THERMAL RESISTANCE
- HIGH SWITCHING CAPABILITY
- LOW FORWARD VOLTAGE DROP

MECHANICAL DATA

- Case: JEDEC DO-41 molded plastic (U/L Flammability Rating 94V-0)
- Terminals: Plated axial leads
- Solderability: Per MIL-STD 202 Method 208 guaranteed
- Polarity: Color band denotes cathode
- Mounting Position: Any
- Weight: 0.013 Ounces (0.35 Grams)

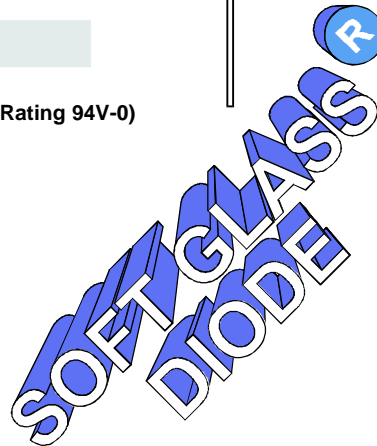

MECHANICAL SPECIFICATION

ACTUAL SIZE OF DO-41 PACKAGE

SERIES: SPR21 - SPR23
 UFR24 - UFR28

DO - 41

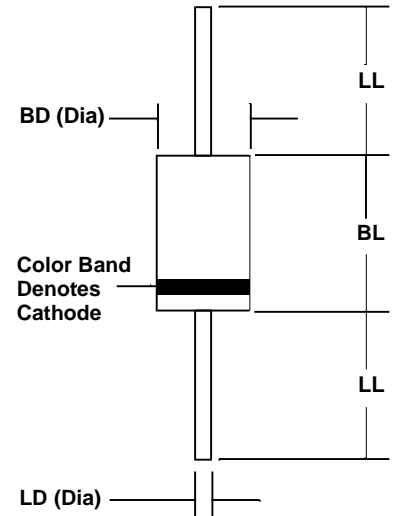

Sym	Minimum		Maximum	
	In	mm	In	mm
BL	0.160	4.1	0.205	5.2
BD	0.103	2.6	0.107	2.7
LL	1.00	25.4		
LD	0.028	0.71	0.034	0.86

MAXIMUM RATINGS & ELECTRICAL CHARACTERISTICS

Ratings at 25 °C ambient temperature unless otherwise specified.
 Single phase, half wave, 60Hz, resistive or inductive load.
 For capacitive loads, derate current by 20%.

PARAMETER (TEST CONDITIONS)	SYMBOL	RATINGS						UNITS
		SPR21	SPR22	SPR23	UFR24	UFR26	UFR28	
Series Number								
Maximum DC Blocking Voltage	V _{RM}	100	200	300	400	600	800	VOLTS
Maximum RMS Voltage	V _{RMS}	70	140	210	280	420	560	
Maximum Peak Recurrent Reverse Voltage	V _{RRM}	100	200	300	400	600	800	
Average Forward Rectified Current @ T _A = 55 °C	I _O	2						AMPS
Peak Forward Surge Current (8.3mS single half sine wave superimposed on rated load)	I _{FSM}	50			70			
Maximum Forward Voltage at 2 Amps DC	V _{FM}	1.0			1.5			VOLTS
Maximum Average DC Reverse Current @ T _C = 25 °C	I _{RM}	2.0						μA
At Rated DC Blocking Voltage @ T _C = 100 °C		50						
Typical Thermal Resistance, Junction to Ambient	R _{θJA}	40						°C/W
Typical Junction Capacitance (Note 1)	C _J	60						pF
Maximum Reverse Recovery Time (I _F =0.5A, I _R =1A, I _{RR} =0.25A)	T _{RR}	35			50	75		nSec
Junction Operating and Storage Temperature Range	T _J , T _{STG}	-65 to +150						°C

NOTES: (1) Measured at 1 MHz and an applied reverse voltage of 4 volts.

4.9715652

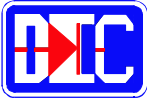

2 AMP SUPER EFFICIENT RECTIFIERS/ULTRAFAST RECOVERY DIODES

RATING & CHARACTERISTIC CURVES FOR SERIES SPR21 - SPR23 and SERIES UFR24 - UFR28

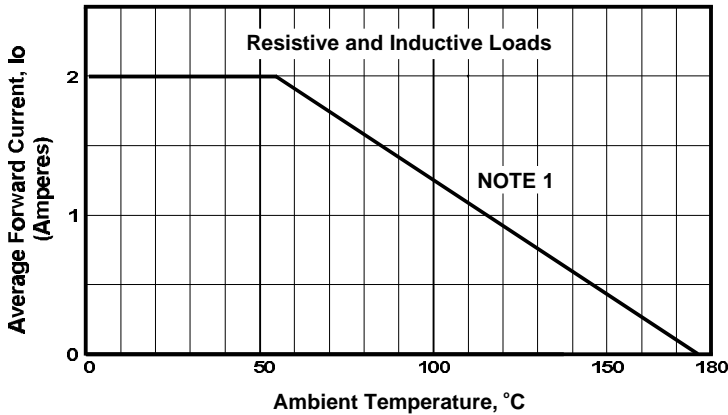

FIGURE 1. FORWARD CURRENT DERATING CURVE

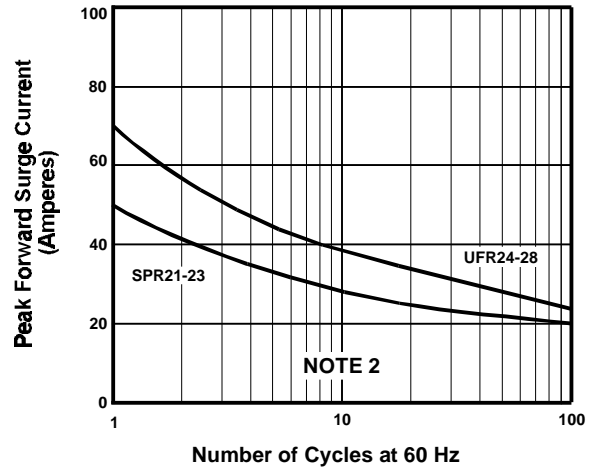

FIGURE 2. MAXIMUM NON-REPETITIVE SURGE CURRENT

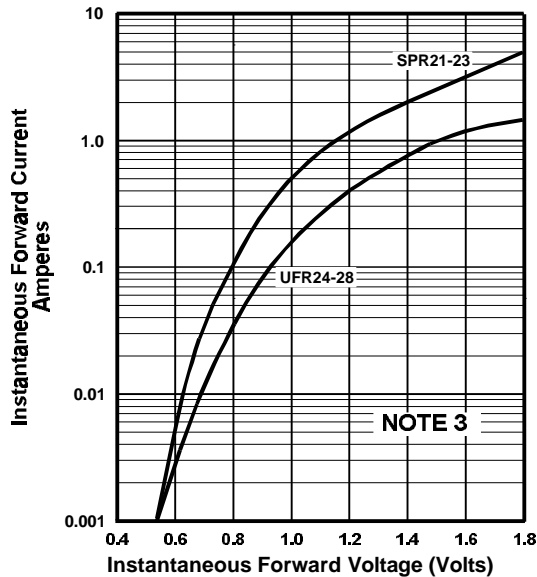

FIGURE 3. TYPICAL FORWARD CHARACTERISTICS

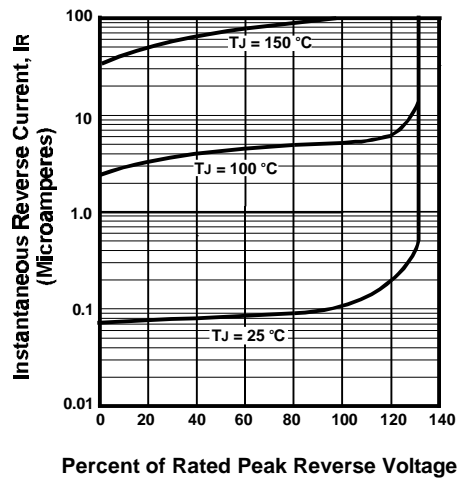

FIGURE 4. TYPICAL REVERSE CHARACTERISTICS

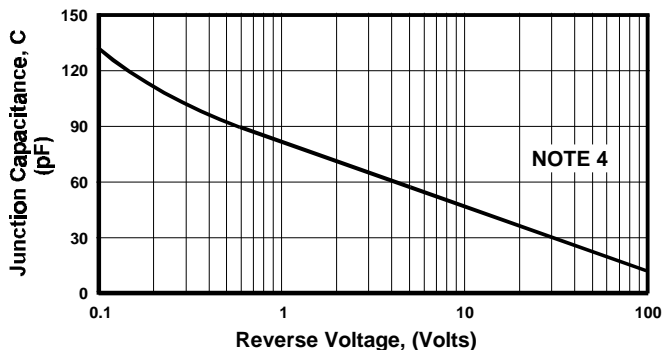
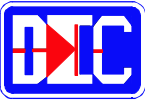

FIGURE 5. TYPICAL JUNCTION CAPACITANCE

NOTES

- (1) Single Phase, Half Wave, 60 Hz; Lead Length = 0.375" (9.5mm)
- (2) JEDEC Method, 8.3 mSec. Single Half Sine Wave;
- (3) $T_J = 25^\circ\text{C}$, Pulse Width = 300 μSec , 2.0% Duty Cycle
- (4) $T_J = 25^\circ\text{C}$, $f = 1.0\text{ MHz}$,



3 AMP SUPER-EFFICIENT RECTIFIERS

FEATURES

- PROPRIETARY **SOFT GLASS[®]** JUNCTION PASSIVATION FOR SUPERIOR RELIABILITY AND PERFORMANCE
- VOID FREE VACUUM DIE SOLDERING FOR MAXIMUM MECHANICAL STRENGTH AND HEAT DISSIPATION (Solder Voids: Typical $\leq 2\%$, Max. $\leq 10\%$ of Die Area)
- LOW SWITCHING NOISE
- LOW THERMAL RESISTANCE
- HIGH SWITCHING CAPABILITY
- LOW FORWARD VOLTAGE DROP

MECHANICAL DATA

- Case: JEDEC DO-27 molded plastic (U/L Flammability Rating 94V-0)
- Terminals: Plated axial leads
- Solderability: Per MIL-STD 202 Method 208 guaranteed
- Polarity: Color band denotes cathode
- Mounting Position: Any
- Weight: 0.04 Ounces (1.12 Grams)

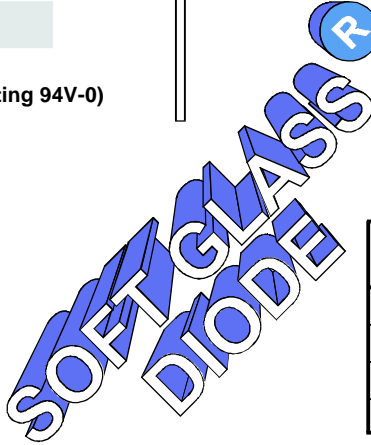

MECHANICAL SPECIFICATION

ACTUAL SIZE OF DO-27 PACKAGE

SERIES SPR30 - SPR34

DO - 27

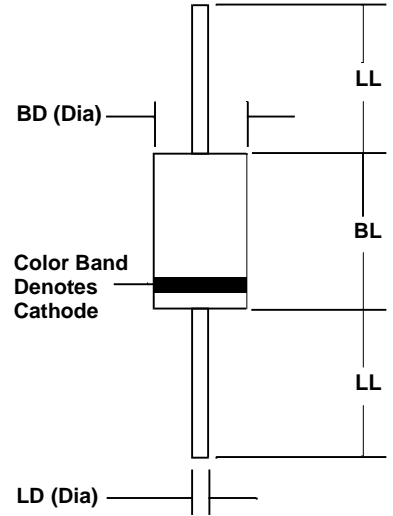
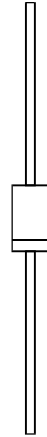

Sym	Minimum		Maximum	
	In	mm	In	mm
BL			0.365	9.28
BD			0.205	5.2
LL	1.00	25.4		
LD	0.048	1.2	0.052	1.3

MAXIMUM RATINGS & ELECTRICAL CHARACTERISTICS

Ratings at 25 °C ambient temperature unless otherwise specified.
 Single phase, half wave, 60Hz, resistive or inductive load.
 For capacitive loads, derate current by 20%.

PARAMETER (TEST CONDITIONS)	SYMBOL	RATINGS					UNITS
		SPR30	SPR31	SPR32	SPR33	SPR34	
Series Number		SPR30	SPR31	SPR32	SPR33	SPR34	
Maximum DC Blocking Voltage	V _{RM}	50	100	200	300	400	VOLTS
Maximum RMS Voltage	V _{RMS}	35	70	140	210	280	
Maximum Peak Recurrent Reverse Voltage	V _{RRM}	50	100	200	300	400	
Average Forward Rectified Current @ T _A = 55 °C	I _O	3					AMPS
Peak Forward Surge Current (8.3mS single half sine wave superimposed on rated load)	I _{FSM}	75					
Maximum Forward Voltage at 3 Amps DC	V _{FM}	1.0		1.25			VOLTS
Maximum Average DC Reverse Current @ T _C = 25 °C	I _{RM}	5.0					μA
At Rated DC Blocking Voltage @ T _C = 100 °C		50					
Typical Thermal Resistance, Junction to Ambient	R _{θJA}	20					°C/W
Typical Junction Capacitance (Note 1)	C _J	100					pF
Maximum Reverse Recovery Time (I _F =0.5A, I _R =1A, I _{RR} =0.25A)	T _{RR}	35					nSec
Junction Operating and Storage Temperature Range	T _J , T _{STG}	-65 to +150					°C

NOTES: (1) Measured at 1 MHz and an applied reverse voltage of 4 volts.

4.975esa3



3 AMP SUPER EFFICIENT RECTIFIERS

RATING & CHARACTERISTIC CURVES FOR SERIES SPR30 - SPR34

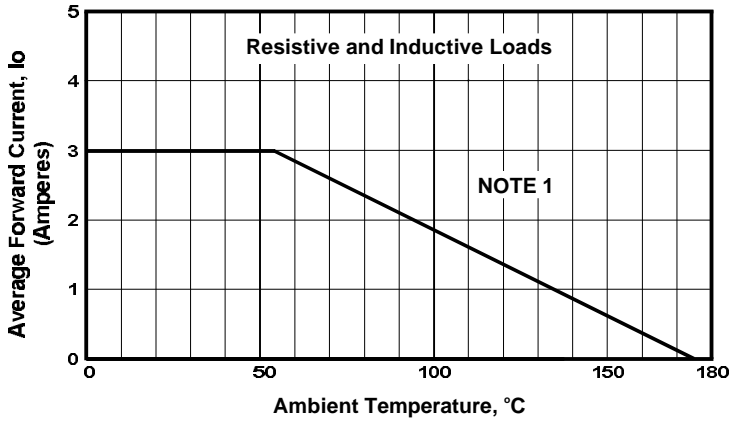

FIGURE 1. FORWARD CURRENT DERATING CURVE

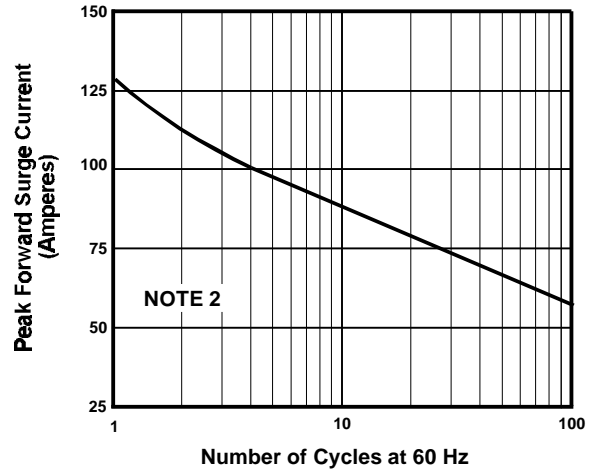

FIGURE 2. MAXIMUM NON-REPETITIVE SURGE CURRENT

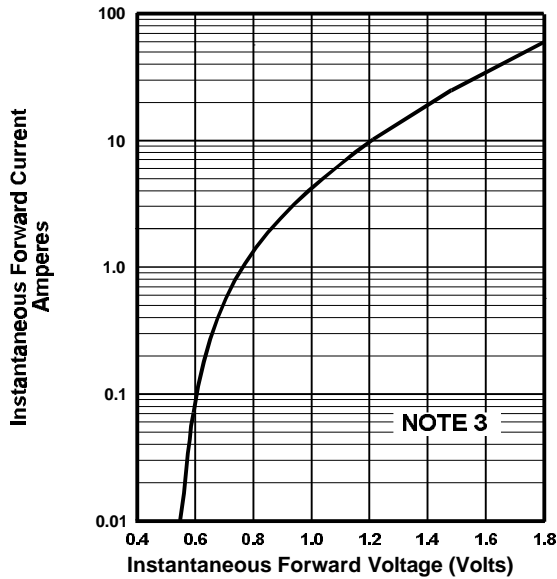

FIGURE 3. TYPICAL FORWARD CHARACTERISTICS

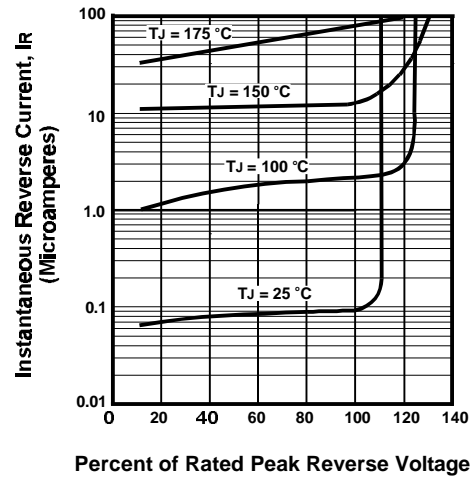

FIGURE 4. TYPICAL REVERSE CHARACTERISTICS

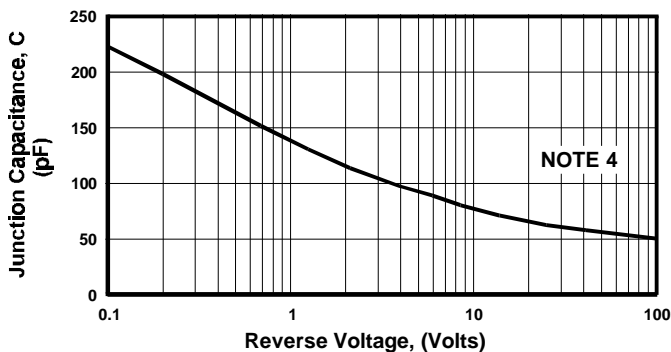
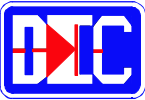

FIGURE 5. TYPICAL JUNCTION CAPACITANCE

NOTES

- (1) Single Phase, Half Wave, 60 Hz; Lead Length = 0.375" (9.5mm)
- (2) JEDEC Method, 8.3 mSec. Single Half Sine Wave; $T_A = 55^\circ\text{C}$
- (3) $T_J = 25^\circ\text{C}$, Pulse Width = 300 μSec , 1.0% Duty Cycle
- (4) $T_J = 25^\circ\text{C}$, $f = 1.0\text{ MHz}$, $V_{\text{SIG}} = 50\text{ mV P-P}$



3 AMP ULTRAFAST RECOVERY DIODES

FEATURES

- PROPRIETARY **SOFT GLASS[®]** JUNCTION PASSIVATION FOR SUPERIOR RELIABILITY AND PERFORMANCE
- VOID FREE VACUUM DIE SOLDERING FOR MAXIMUM MECHANICAL STRENGTH AND HEAT DISSIPATION (Solder Voids: Typical $\leq 2\%$, Max. $\leq 10\%$ of Die Area)
- LOW SWITCHING NOISE
- LOW THERMAL RESISTANCE
- HIGH SWITCHING CAPABILITY
- LOW FORWARD VOLTAGE DROP

MECHANICAL DATA

- Case: JEDEC DO-27 molded plastic (U/L Flammability Rating 94V-0)
- Terminals: Plated axial leads
- Solderability: Per MIL-STD 202 Method 208 guaranteed
- Polarity: Color band denotes cathode
- Mounting Position: Any
- Weight: 0.04 Ounces (1.12 Grams)

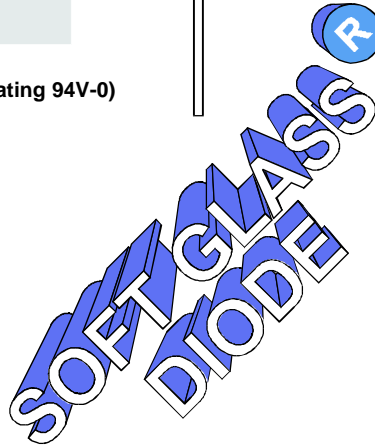

MECHANICAL SPECIFICATION

ACTUAL SIZE OF DO-27 PACKAGE

SERIES UFR300 - UFR310

DO - 27

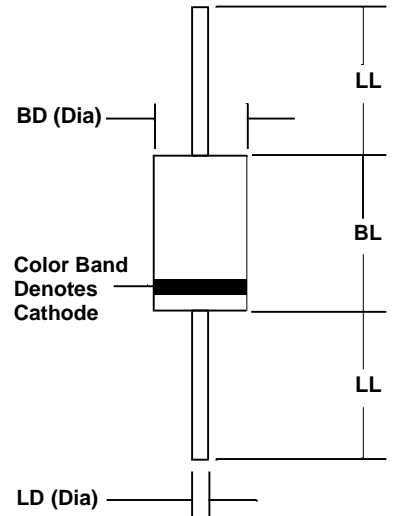

Sym	Minimum		Maximum	
	In	mm	In	mm
BL			0.365	9.28
BD			0.205	5.2
LL	1.00	25.4		
LD	0.048	1.2	0.052	1.3

MAXIMUM RATINGS & ELECTRICAL CHARACTERISTICS

Ratings at 25 °C ambient temperature unless otherwise specified.
 Single phase, half wave, 60Hz, resistive or inductive load.
 For capacitive loads, derate current by 20%.

PARAMETER (TEST CONDITIONS)	SYMBOL	RATINGS										UNITS
		UFR 300	UFR 301	UFR 302	UFR 303	UFR 304	UFR 305	UFR 306	UFR 308	UFR 310		
Series Number												
Maximum DC Blocking Voltage	VRM	50	100	200	300	400	500	600	800	1000		
Maximum RMS Voltage	VRMS	35	70	140	210	280	350	420	560	700	VOLTS	
Maximum Peak Recurrent Reverse Voltage	VRRM	50	100	200	300	400	500	600	800	1000		
Average Forward Rectified Current @ TA = 55 °C	IO	3										AMPS
Peak Forward Surge Current (8.3mS single half sine wave superimposed on rated load)	IFSM	160										
Maximum Forward Voltage at 3 Amps DC	VFM	1.25					1.7					VOLTS
Maximum Average DC Reverse Current @ Tc = 25° C	IRM	5										µA
At Rated DC Blocking Voltage @ Tc = 125° C		50										
Typical Thermal Resistance, Junction to Lead	RθJA	20										°C/W
Typical Junction Capacitance (Note 1)	CJ	45										pF
Maximum Reverse Recovery Time (IF=0.5A, IR=1A, IRR=0.25A)	TRR	50					75					nSec
Junction Operating and Storage Temperature Range	TJ, TSTG	-65 to +150										°C

NOTES: (1) Measured at 1 MHz and an applied reverse voltage of 4 volts.

3.01 ufr300



3 AMP ULTRAFAST RECOVERY DIODES

RATING & CHARACTERISTIC CURVES FOR SERIES UFR300 - UFR310

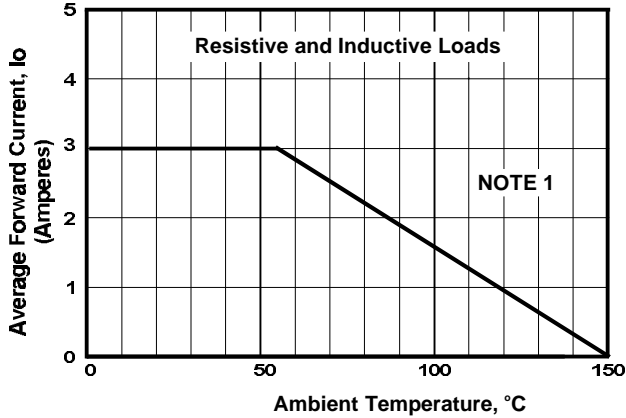

FIGURE 1. FORWARD CURRENT DERATING CURVE

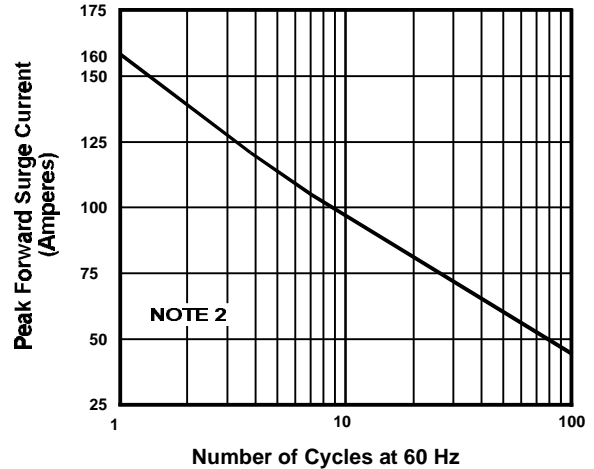

FIGURE 2. MAXIMUM NON-REPETITIVE SURGE CURRENT

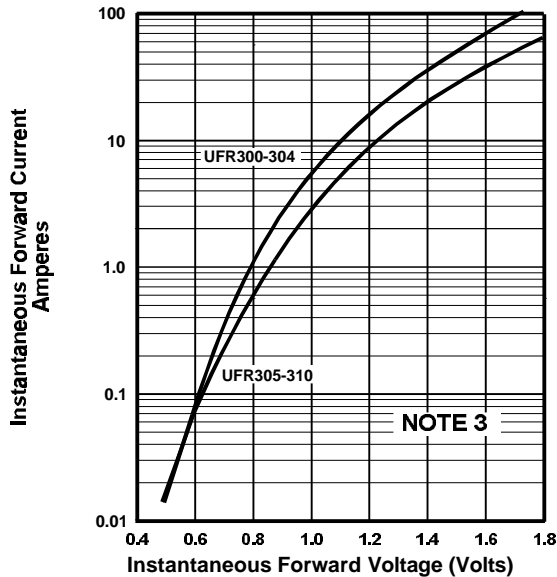

FIGURE 3. TYPICAL FORWARD CHARACTERISTICS

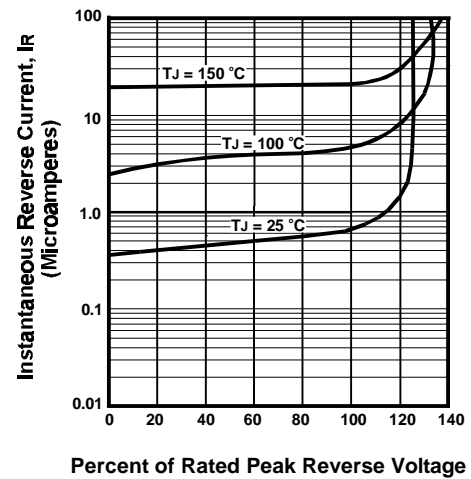

FIGURE 4. TYPICAL REVERSE CHARACTERISTICS

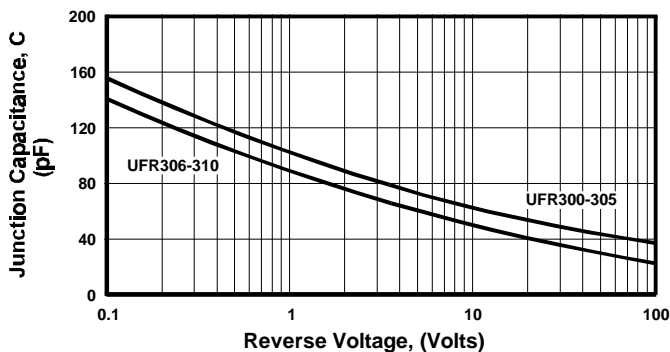
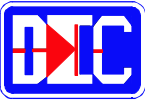

FIGURE 5. TYPICAL JUNCTION CAPACITANCE

NOTES

- (1) Single Phase, Half Wave, 60 Hz; Lead Length = 0.375" (9.5mm)
- (2) JEDEC Method, 8.3 mSec. Single Half Sine Wave;
- (3) $T_J = 25^\circ\text{C}$, Pulse Width = 300 μSec , 2.0% Duty Cycle



4 AMP ULTRAFAST RECOVERY DIODES

FEATURES

- PROPRIETARY **SOFT GLASS[®]** JUNCTION PASSIVATION FOR SUPERIOR RELIABILITY AND PERFORMANCE
- VOID FREE VACUUM DIE SOLDERING FOR MAXIMUM MECHANICAL STRENGTH AND HEAT DISSIPATION (Solder Voids: Typical $\leq 2\%$, Max. $\leq 10\%$ of Die Area)
- LOW SWITCHING NOISE
- LOW THERMAL RESISTANCE
- HIGH SWITCHING CAPABILITY
- LOW FORWARD VOLTAGE DROP

MECHANICAL DATA

- Case: JEDEC DO-27 molded plastic (U/L Flammability Rating 94V-0)
- Terminals: Plated axial leads
- Solderability: Per MIL-STD 202 Method 208 guaranteed
- Polarity: Color band denotes cathode
- Mounting Position: Any
- Weight: 0.04 Ounces (1.12 Grams)

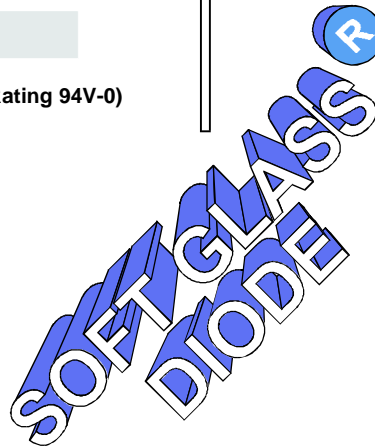

MECHANICAL SPECIFICATION

ACTUAL SIZE OF DO-27 PACKAGE

SERIES UFR400 - UFR410

DO - 27

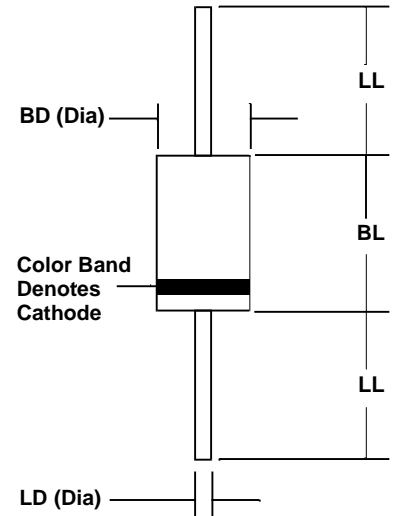

Sym	Minimum		Maximum	
	In	mm	In	mm
BL			0.365	9.28
BD			0.205	5.2
LL	1.00	25.4		
LD	0.048	1.2	0.052	1.3

MAXIMUM RATINGS & ELECTRICAL CHARACTERISTICS

Ratings at 25 °C ambient temperature unless otherwise specified.
 Single phase, half wave, 60Hz, resistive or inductive load.
 For capacitive loads, derate current by 20%.

PARAMETER (TEST CONDITIONS)	SYMBOL	RATINGS										UNITS
		UFR 400	UFR 401	UFR 402	UFR 403	UFR 404	UFR 406	UFR 408	UFR 409	UFR 410		
Series Number												
Maximum DC Blocking Voltage	V _{RM}	50	100	200	300	400	600	800	900	1000	VOLTS	
Maximum RMS Voltage	V _{RMS}	35	70	140	210	280	420	560	630	700		
Maximum Peak Recurrent Reverse Voltage	V _{RRM}	50	100	200	300	400	600	800	900	1000		
Average Forward Rectified Current @ T _A = (as shown)	I _O	4 @ T _A = 80° C					4 @ T _A = 55° C					AMPS
Peak Forward Surge Current (8.3mS single half sine wave superimposed on rated load)	I _{FSM}	200										
Maximum Forward Voltage at:	V _{FM}	1.20 1.25					1.70 1.85					VOLTS
Maximum Average DC Reverse Current At Rated DC Blocking Voltage	I _{RM}	5 50					10 50					
Typical Thermal Resistance:	R _{θJL} R _{θJA}	7.5 18.0										°C/W
Typical Junction Capacitance (Note 1)	C _J	45										
Maximum Reverse Recovery Time (I _F =0.5A, I _R =1A, I _{RR} =0.25A)	T _{RR}	50			60			75				nSec
Junction Operating and Storage Temperature Range	T _J , T _{STG}	-65 to +175										

NOTES: (1) Measured at 1MHz and an applied reverse voltage of 4 volts.

3.01 ufr400

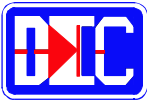

4 AMP ULTRAFAST RECOVERY DIODES

RATING & CHARACTERISTIC CURVES FOR SERIES UFR400 - UFR410

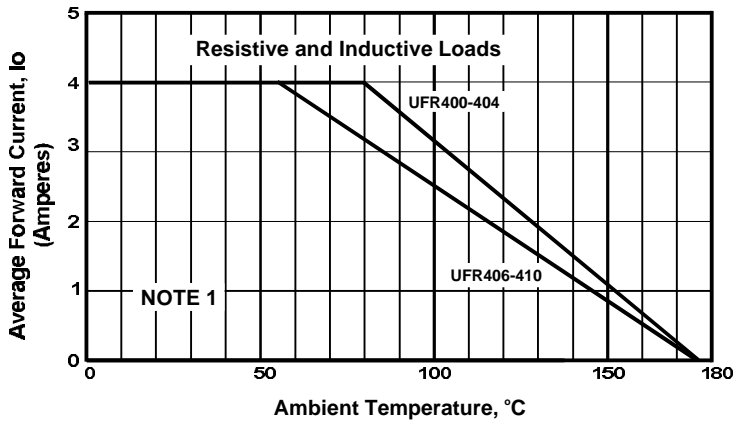

FIGURE 1. FORWARD CURRENT DERATING CURVE

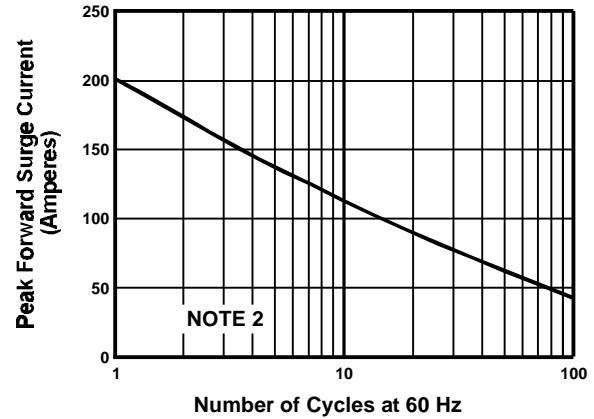

FIGURE 2. MAXIMUM NON-REPETITIVE SURGE CURRENT

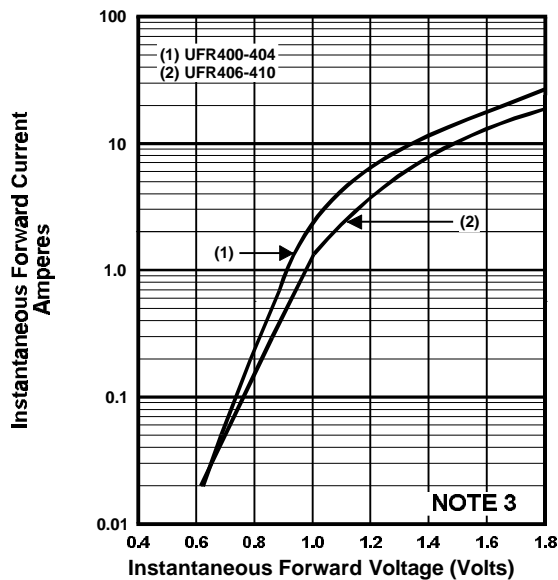

FIGURE 3. TYPICAL FORWARD CHARACTERISTICS

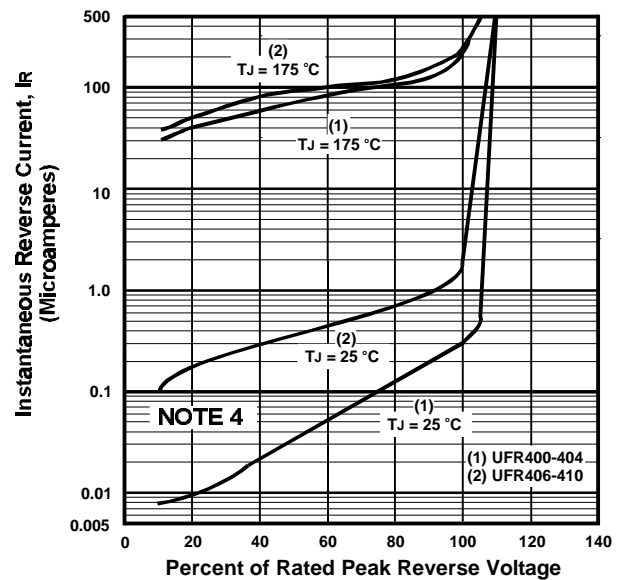

FIGURE 4. TYPICAL REVERSE CHARACTERISTICS

NOTES

- (1) Lead Length = 0.375" (9.5mm)
- (2) JEDEC Method, 8.3 mSec. Single Half Sine Wave
- (3) $T_J = 25^\circ\text{C}$, Pulse Width = 300 μSec , 2.0% Duty Cycle
- (4) These Curves Are Typical For The Highest Voltage Diode in The Voltage Grouping.

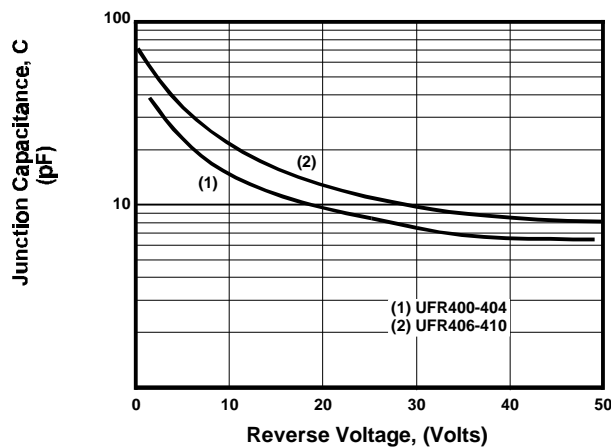
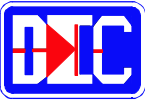

FIGURE 5. TYPICAL JUNCTION CAPACITANCE



5 AMP SUPER-EFFICIENT RECTIFIERS

FEATURES

- PROPRIETARY **SOFT GLASS[®]** JUNCTION PASSIVATION FOR SUPERIOR RELIABILITY AND PERFORMANCE
- VOID FREE VACUUM DIE SOLDERING FOR MAXIMUM MECHANICAL STRENGTH AND HEAT DISSIPATION (Solder Voids: Typical $\leq 2\%$, Max. $\leq 10\%$ of Die Area)
- LOW SWITCHING NOISE
- LOW THERMAL RESISTANCE
- HIGH SWITCHING CAPABILITY
- LOW FORWARD VOLTAGE DROP

MECHANICAL DATA

- Case: JEDEC DO-27 molded plastic (U/L Flammability Rating 94V-0)
- Terminals: Plated axial leads
- Solderability: Per MIL-STD 202 Method 208 guaranteed
- Polarity: Color band denotes cathode
- Mounting Position: Any
- Weight: 0.04 Ounces (1.12 Grams)

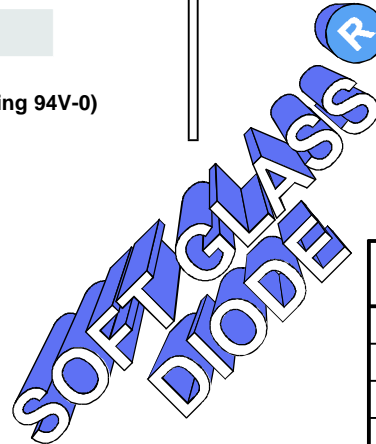

MECHANICAL SPECIFICATION

ACTUAL SIZE OF DO-27 PACKAGE

SERIES SPR51 - SPR54

DO - 27

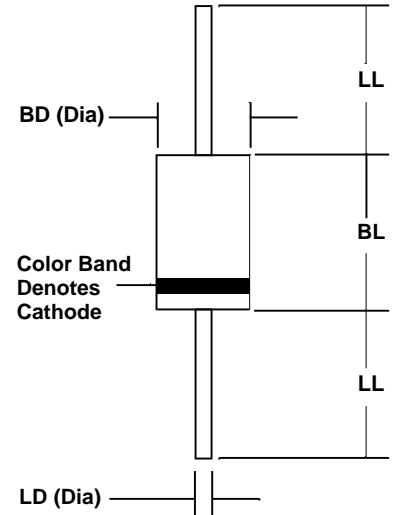

Sym	Minimum		Maximum	
	In	mm	In	mm
BL			0.365	9.28
BD			0.205	5.2
LL	1.00	25.4		
LD	0.048	1.2	0.052	1.3

MAXIMUM RATINGS & ELECTRICAL CHARACTERISTICS

Ratings at 25 °C ambient temperature unless otherwise specified.
 Single phase, half wave, 60Hz, resistive or inductive load.
 For capacitive loads, derate current by 20%.

PARAMETER (TEST CONDITIONS)	SYMBOL	RATINGS				UNITS
		SPR51	SPR52	SPR53	SPR54	
Series Number		SPR51	SPR52	SPR53	SPR54	
Maximum DC Blocking Voltage	V _{RM}	100	200	300	400	VOLTS
Maximum RMS Voltage	V _{RMS}	70	140	210	280	
Maximum Peak Recurrent Reverse Voltage	V _{RRM}	100	200	300	400	
Average Forward Rectified Current @ T _A = 55 °C	I _O	5				AMPS
Peak Forward Surge Current (8.3mS single half sine wave superimposed on rated load)	I _{FSM}	150				
Maximum Forward Voltage at 5 Amps DC	V _{FM}	1.25				VOLTS
Maximum Average DC Reverse Current At Rated DC Blocking Voltage	I _{RM}	5				μA
Typical Thermal Resistance, Junction to Ambient	R _{θJA}	20				°C/W
Typical Junction Capacitance (Note 1)	C _J	75				pF
Maximum Reverse Recovery Time (I _F =0.5A, I _R =1A, I _{RR} =0.25A)	T _{RR}	50				nSec
Junction Operating and Storage Temperature Range	T _J , T _{STG}	-65 to +150				°C

NOTES: (1) Measured at 1 MHz and an applied reverse voltage of 4 volts.

4.975esa5

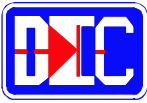

5 AMP SUPER EFFICIENT RECTIFIERS

RATING & CHARACTERISTIC CURVES FOR SERIES SPR51 - SPR54

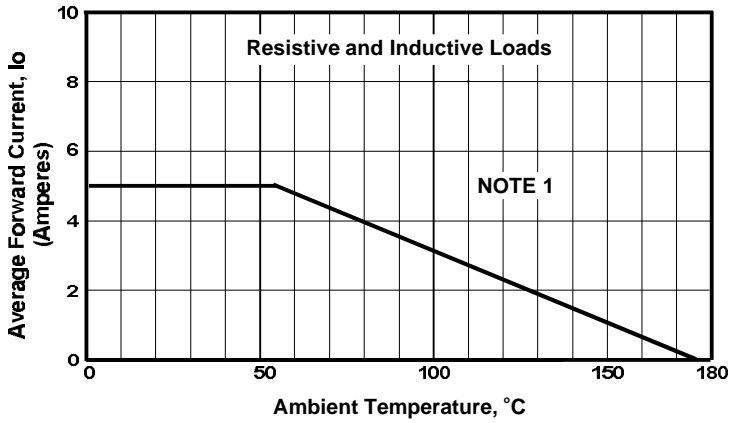

FIGURE 1. FORWARD CURRENT DERATING CURVE

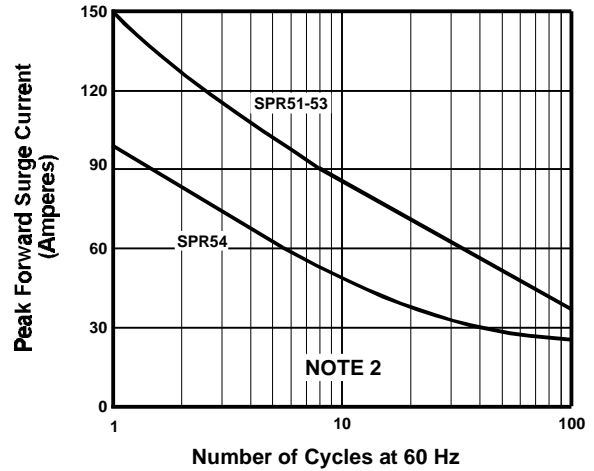

FIGURE 2. MAXIMUM NON-REPETITIVE SURGE CURRENT

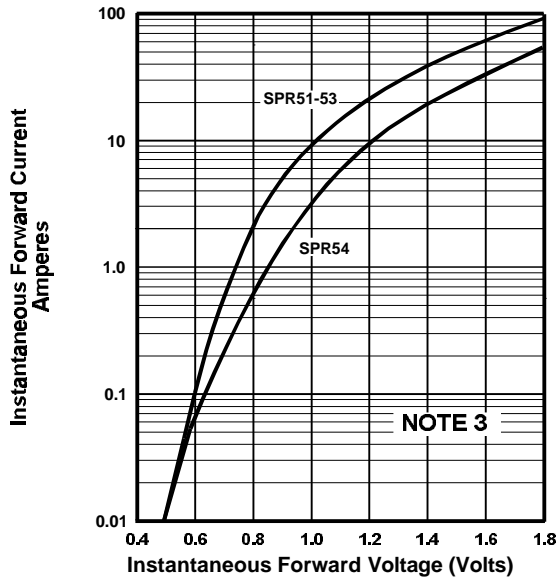

FIGURE 3. TYPICAL FORWARD CHARACTERISTICS

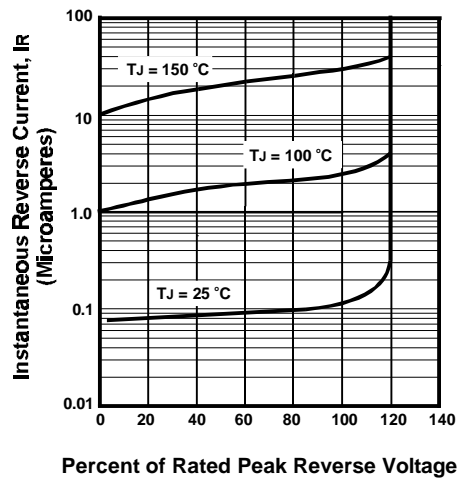

FIGURE 4. TYPICAL REVERSE CHARACTERISTICS

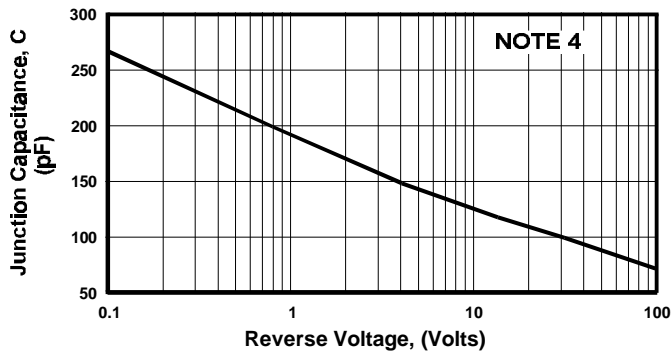
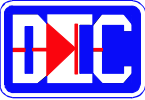

FIGURE 5. TYPICAL JUNCTION CAPACITANCE

NOTES

- (1) Single Phase, Half Wave, 60 Hz; Lead Length = 0.375" (9.5mm)
- (2) JEDEC Method, 8.3 mSec. Single Half Sine Wave; T_L = 55 °C
- (3) T_J = 25 °C, Pulse Width = 300 μSec, 1.0% Duty Cycle
- (4) T_J = 25 °C, f = 1 MHz, V_{SIG} = 50 mV P-P



6 AMP ULTRAFAST RECOVERY DIODES

FEATURES

- Low switching noise
- Low forward voltage drop
- Low thermal resistance
- High switching capability
- High surge capability
- High reliability

MECHANICAL DATA

- Case: Molded epoxy (U/L Flammability Rating 94V-0)
- Terminals: Plated axial leads
- Solderability: Per MIL-STD 202 Method 208 guaranteed
- Polarity: Color band denotes cathode
- Mounting Position: Any
- Weight: 0.07 Ounces (2.1 Grams)

MECHANICAL SPECIFICATION

ACTUAL SIZE OF UFR600 PACKAGE



SERIES UFR600 - UFR608

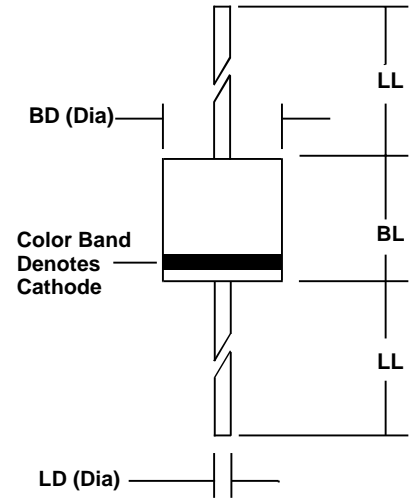

Sym	Minimum		Maximum	
	In	mm	In	mm
BL	0.340	8.6	0.360	9.1
BD	0.340	8.6	0.360	9.1
LL	1.00	25.4		
LD	0.048	1.2	0.052	1.3

MAXIMUM RATINGS & ELECTRICAL CHARACTERISTICS

Ratings at 25 °C ambient temperature unless otherwise specified.
 Single phase, half wave, 60Hz, resistive or inductive load.
 For capacitive loads, derate current by 20%.

PARAMETER (TEST CONDITIONS)	SYMBOL	RATINGS								UNITS
		UFR 600	UFR 601	UFR 602	UFR 603	UFR 604	UFR 606	UFR 608		
Series Number										
Maximum DC Blocking Voltage	V _{RM}	50	100	200	300	400	600	800		VOLTS
Maximum RMS Voltage	V _{RMS}	35	70	140	210	280	420	560		
Maximum Peak Recurrent Reverse Voltage	V _{RRM}	50	100	200	300	400	600	800		
Average Forward Rectified Current @ T _A = 55 °C	I _O	6								AMPS
Peak Forward Surge Current (8.3mS single half sine wave superimposed on rated load)	I _{FSM}	300								
Maximum Forward Voltage at 6 Amps DC	V _{FM}	1.25						1.4		VOLTS
Maximum Average DC Reverse Current At Rated DC Blocking Voltage	I _{RM}	10 200								μA
Typical Thermal Resistance, Junction to Case	R _{θJC}	10								°C/W
Typical Junction Capacitance (Note 1)	C _J	100								pF
Maximum Reverse Recovery Time (I _F =0.5A, I _R =1A, I _{RR} =0.25A)	T _{RR}	60			75			90		nSec
Junction Operating and Storage Temperature Range	T _J , T _{STG}	-65 to +150								°C

NOTES: (1) Measured at 1 MHz and an applied reverse voltage of 4 volts.

01.00 fsesa6



6 AMP ULTRAFAST RECOVERY DIODES

RATING & CHARACTERISTIC CURVES FOR SERIES UFR600 - UFR608

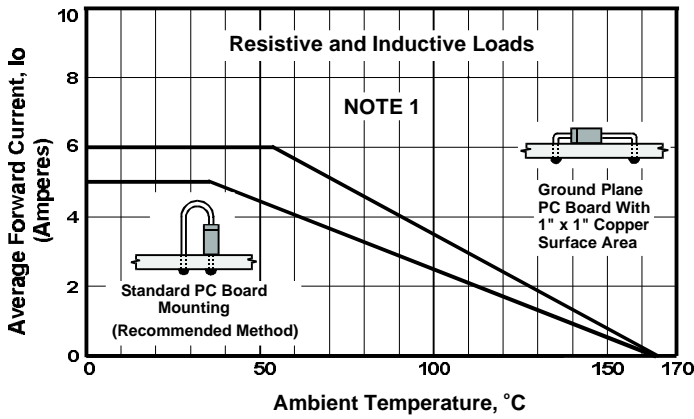

FIGURE 1. FORWARD CURRENT DERATING CURVE

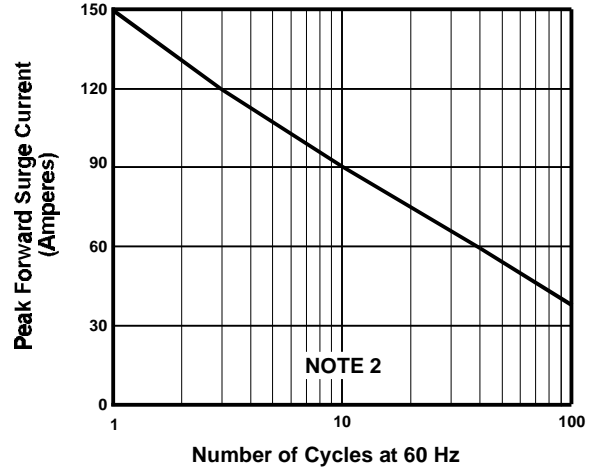

FIGURE 2. MAXIMUM NON-REPETITIVE SURGE CURRENT

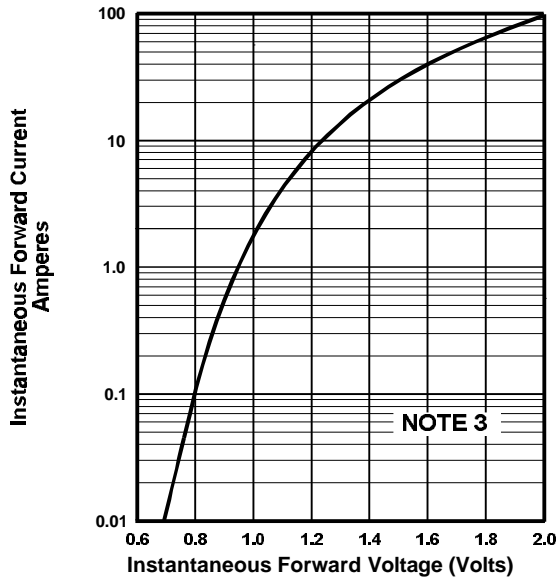

FIGURE 3. TYPICAL FORWARD CHARACTERISTICS

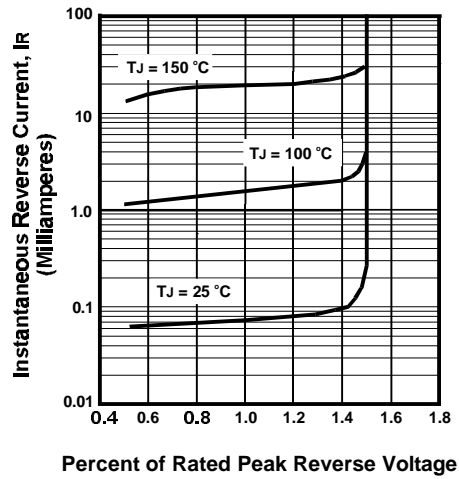

FIGURE 4. TYPICAL REVERSE CHARACTERISTICS

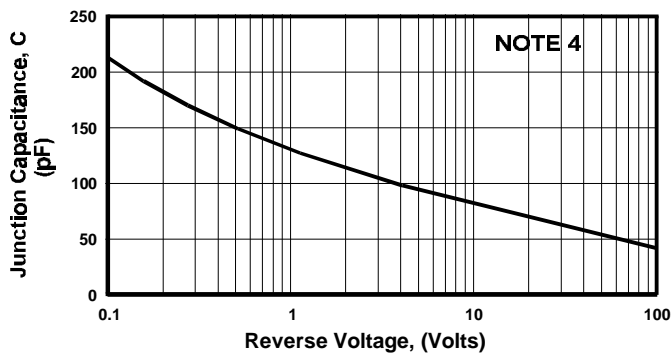
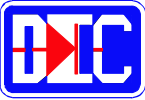

FIGURE 5. TYPICAL JUNCTION CAPACITANCE

NOTES

- (1) Single Phase, Half Wave, 60 Hz
- (2) JEDEC Method, 8.3 mSec. Single Half Sine Wave;
- (3) $T_J = 25^\circ\text{C}$, Pulse Width = 300 μSec , 2.0% Duty Cycle
- (4) $T_J = 25^\circ\text{C}$, $f = 1\text{ MHz}$, $V_{\text{SIG}} = 50\text{ mV P-P}$



6 AMP SUPER-EFFICIENT RECTIFIERS

FEATURES

- Glass Passivated for high reliability/temperature performance
- Low switching noise
- Low forward voltage drop
- Low thermal resistance
- High switching capability
- High surge capability

MECHANICAL DATA

- Case: TO-220 molded plastic (Fully Insulated)
(U/L Flammability Rating 94V-0)
- Terminals: Rectangular pins w/ standoff
- Solderability: Per MIL-STD 202 Method 208 guaranteed
- Polarity: Diode depicted on product
- Mounting Position: Any
- Weight: 0.06 Ounces (1.7 Grams)

MECHANICAL SPECIFICATION

ACTUAL SIZE OF
TO-220AC PACKAGE

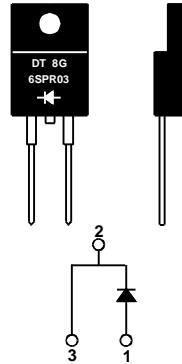

FULLY INSULATED PACKAGE

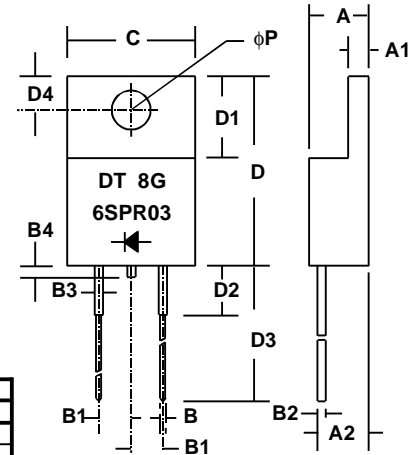

Sym	Minimum		Maximum	
	in	mm	in	mm
A			0.187	4.75
A1	0.121*	4.75*		
A2	0.14*	3.56*		
B	0.035	0.9	0.043	1.1
B1	0.09	2.3	0.102	2.6
B2	0.025*	0.64*		
B3	0.050*	1.27*		
B4			0.04	1.0
C			0.413	10.5
D	0.59	15.0	0.61	15.5
D1	0.262*	6.6*		
D2			0.16	4.0
D3	0.54	13.7	0.60	15.2
D4	0.108*	2.75*		
φP	0.126*	3.2*		

* These dimensions are "Typicals".

ITO - 220AC

SERIES 6SPR01 - 6SPR05

MAXIMUM RATINGS & ELECTRICAL CHARACTERISTICS

Ratings at 25 °C ambient temperature unless otherwise specified.
 Single phase, half wave, 60Hz, resistive or inductive load.
 For capacitive loads, derate current by 20%.

PARAMETER (TEST CONDITIONS)	SYMBOL	RATINGS					UNITS
		6SPR01	6SPR02	6SPR03	6SPR04	6SPR05	
Series Number							
Maximum DC Blocking Voltage	V _{RM}	100	200	300	400	500	VOLTS
Maximum RMS Voltage	V _{RMS}	70	140	210	280	350	
Maximum Peak Recurrent Reverse Voltage	V _{RRM}	100	200	300	400	500	
Average Forward Rectified Current @ T _c = 100 °C	I _o	6					AMPS
Peak Forward Surge Current (8.3mS single half sine wave superimposed on rated load)	I _{FSM}	80					
Maximum Forward Voltage at 6 Amps DC	V _{FM}	1.05		1.3			VOLTS
Maximum Average DC Reverse Current @ T _c = 25 °C At Rated DC Blocking Voltage @ T _c = 100 °C	I _{RM}	10			500		μA
Typical Thermal Resistance, Junction to Case	R _{θJC}	5					°C/W
Typical Junction Capacitance (Note 1)	C _J	65					pF
Maximum Reverse Recovery Time (I _F =6.0A, di/dt=50A/μS, T _J =25°C)	T _{RR}	35		45			nSec
Junction Operating and Storage Temperature Range	T _J , T _{STG}	-65 to +150					°C

NOTES: (1) Measured at 1 MHz and an applied reverse voltage of 4 volts.

4.97100006

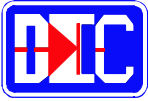

6 AMP SUPER EFFICIENT RECTIFIERS

RATING & CHARACTERISTIC CURVES FOR SERIES 6SPR01 - 6SPR05

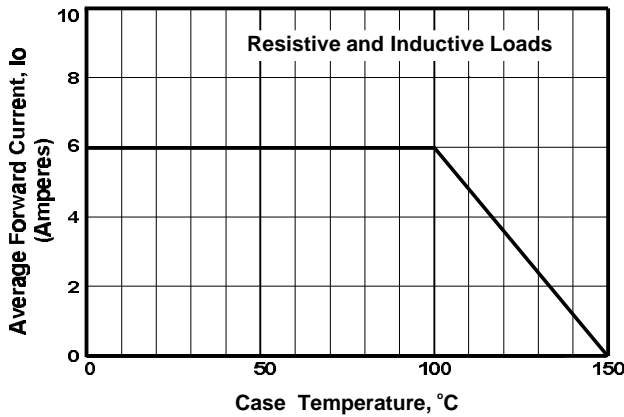

FIGURE 1. FORWARD CURRENT DERATING CURVE

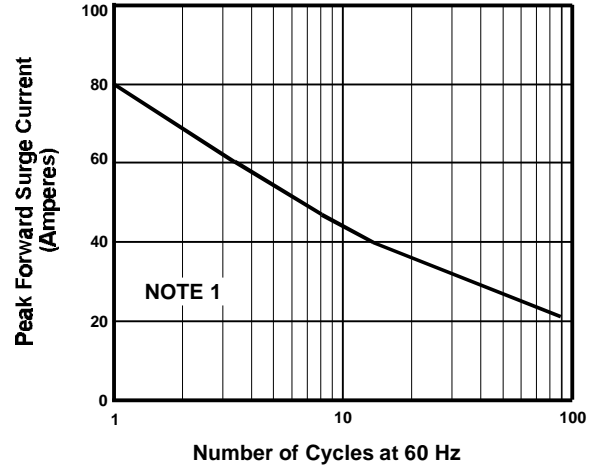

FIGURE 2. MAXIMUM NON-REPETITIVE SURGE CURRENT

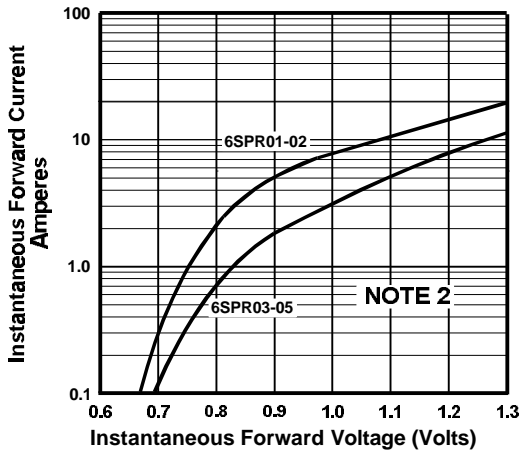

FIGURE 3. TYPICAL FORWARD CHARACTERISTICS

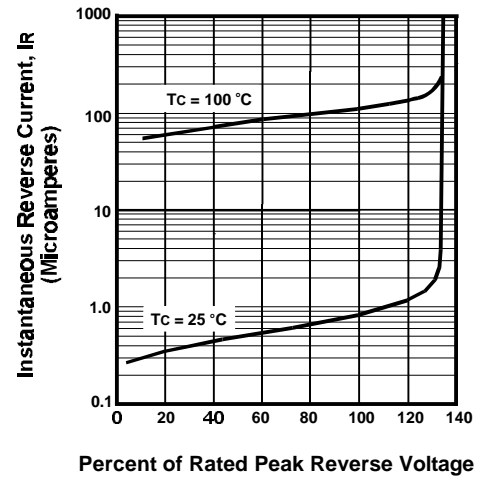

FIGURE 4. TYPICAL REVERSE CHARACTERISTICS

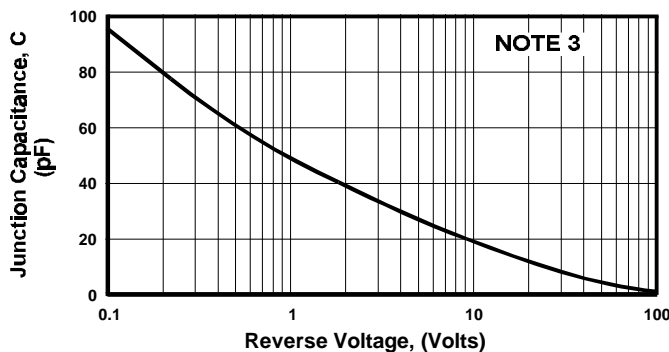
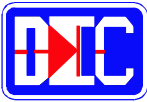

FIGURE 5. TYPICAL JUNCTION CAPACITANCE

NOTES

- (1) JEDEC Method, 8.3 mSec. Single Half Sine Wave
- (2) $T_J = 25^\circ\text{C}$, Pulse Width = 300 μSec , 2.0% Duty Cycle
- (3) $T_C = 25^\circ\text{C}$, $f = 1\text{ MHz}$, $V_{SIG} = 50\text{ mV P-P}$



8 AMP SUPER-EFFICIENT RECTIFIERS

FEATURES

- Glass Passivated for high reliability/temperature performance
- Low switching noise
- Low forward voltage drop
- Low thermal resistance
- High switching capability
- High surge capability

MECHANICAL DATA

- Case: TO-220 molded plastic (Fully Insulated) (U/L Flammability Rating 94V-0)
- Terminals: Rectangular pins w/ standoff
- Solderability: Per MIL-STD 202 Method 208 guaranteed
- Polarity: Diode depicted on product
- Mounting Position: Any
- Weight: 0.06 Ounces (1.7 Grams)

MECHANICAL SPECIFICATION

ACTUAL SIZE OF TO-220AC PACKAGE

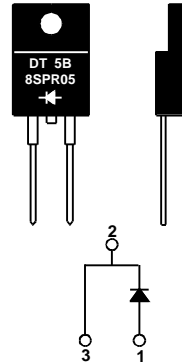

FULLY INSULATED PACKAGE

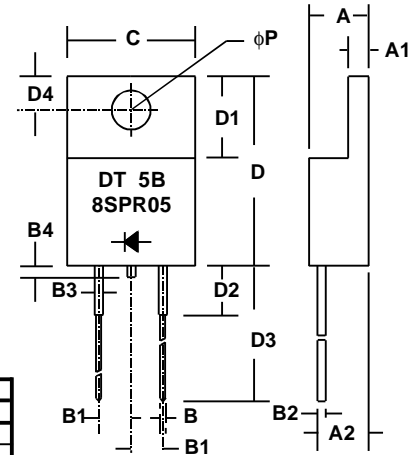

Sym	Minimum		Maximum	
	in	mm	in	mm
A			0.187	4.75
A1	0.121*	4.75*		
A2	0.14*	3.56*		
B	0.035	0.9	0.043	1.1
B1	0.09	2.3	0.102	2.6
B2	0.025*	0.64*		
B3	0.050*	1.27*		
B4			0.04	1.0
C			0.413	10.5
D	0.59	15.0	0.61	15.5
D1	0.262*	6.6*		
D2			0.16	4.0
D3	0.54	13.7	0.60	15.2
D4	0.108*	2.75*		
φP	0.126*	3.2*		

* These dimensions are "Typicals".

ITO - 220AC

SERIES 8SPR01 - 8SPR05

MAXIMUM RATINGS & ELECTRICAL CHARACTERISTICS

Ratings at 25 °C ambient temperature unless otherwise specified.
 Single phase, half wave, 60Hz, resistive or inductive load.
 For capacitive loads, derate current by 20%.

PARAMETER (TEST CONDITIONS)	SYMBOL	RATINGS					UNITS
		8SPR01	8SPR02	8SPR03	8SPR04	8SPR05	
Series Number							
Maximum DC Blocking Voltage	V _{RM}	100	200	300	400	500	VOLTS
Maximum RMS Voltage	V _{RMS}	70	140	210	280	350	
Maximum Peak Recurrent Reverse Voltage	V _{RRM}	100	200	300	400	500	
Average Forward Rectified Current @ T _c = 110 °C	I _o	8					AMPS
Peak Forward Surge Current (8.3mS single half sine wave superimposed on rated load)	I _{FSM}	120					
Maximum Forward Voltage at 8 Amps DC	V _{FM}	1.0		1.2			VOLTS
Maximum Average DC Reverse Current @ T _c = 25 °C At Rated DC Blocking Voltage @ T _c = 100 °C	I _{RM}	10 500					μA
Typical Thermal Resistance, Junction to Case	R _{θJC}	1.5					°C/W
Typical Junction Capacitance (Note)	C _J	45					pF
Maximum Reverse Recovery Time (I _F =8.0A, di/dt=50A/μS, T _J =25°C)	T _{RR}	35		45			nSec
Junction Operating and Storage Temperature Range	T _J , T _{STG}	-65 to +150					°C

NOTES: (1) Measured at 1 MHz and an applied reverse voltage of 4 volts.

4.975csa8

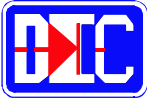

8 AMP SUPER EFFICIENT RECTIFIERS

RATING & CHARACTERISTIC CURVES FOR SERIES 8SPR01 - 8SPR05

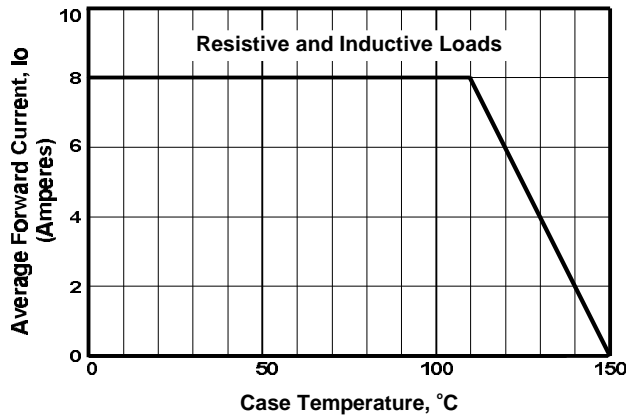

FIGURE 1. FORWARD CURRENT DERATING CURVE

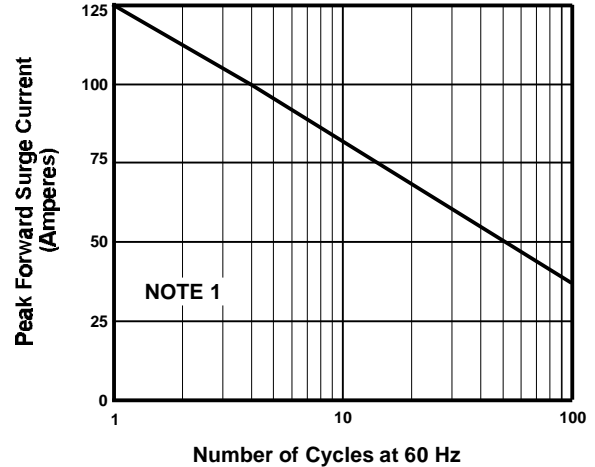

FIGURE 2. MAXIMUM NON-REPETITIVE SURGE CURRENT

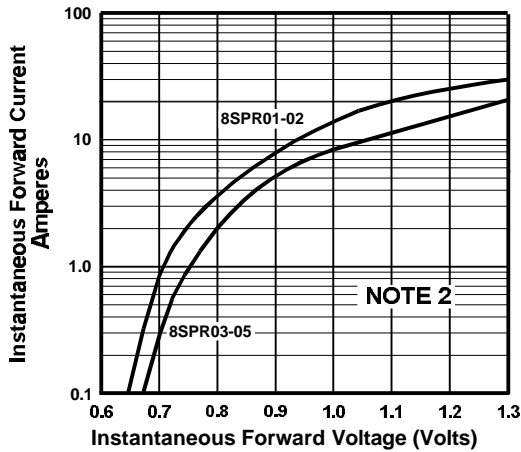

FIGURE 3. TYPICAL FORWARD CHARACTERISTICS

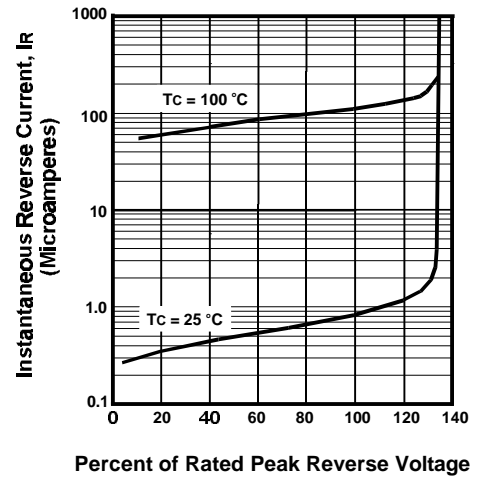

FIGURE 4. TYPICAL REVERSE CHARACTERISTICS

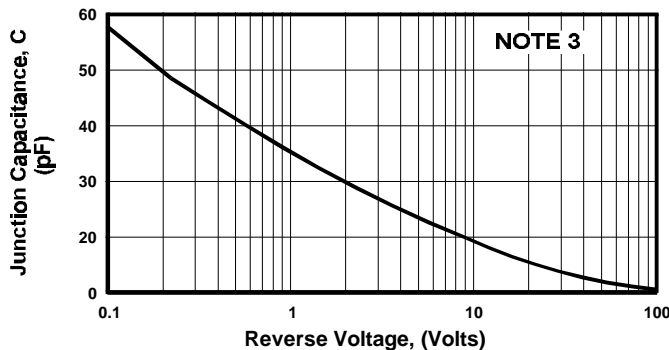
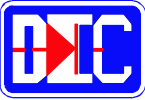

FIGURE 5. TYPICAL JUNCTION CAPACITANCE

NOTES

- (1) JEDEC Method, 8.3 mSec. Single Half Sine Wave
- (2) $T_J = 25^\circ\text{C}$, Pulse Width = 300 μSec , 2.0% Duty Cycle
- (3) $T_C = 25^\circ\text{C}$, $f = 1\text{ MHz}$, $V_{SIG} = 50\text{ mV P-P}$



8 AMP SUPER-EFFICIENT RECTIFIERS

FEATURES

- Glass Passivated for high reliability/temperature performance
- Low switching noise
- Low forward voltage drop
- Low thermal resistance
- High switching capability
- High surge capability

MECHANICAL DATA

- Case: TO-220 molded plastic (U/L Flammability Rating 94V-0)
- Terminals: Rectangular pins w/ standoff
- Solderability: Per MIL-STD 202 Method 208 guaranteed
- Polarity: Diode depicted on product
- Mounting Position: Any
- Weight: 0.08 Ounces (2.2 Grams)

MECHANICAL SPECIFICATION

ACTUAL SIZE OF TO-220AC PACKAGE

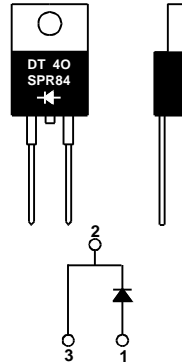

NON - INSULATED PACKAGE

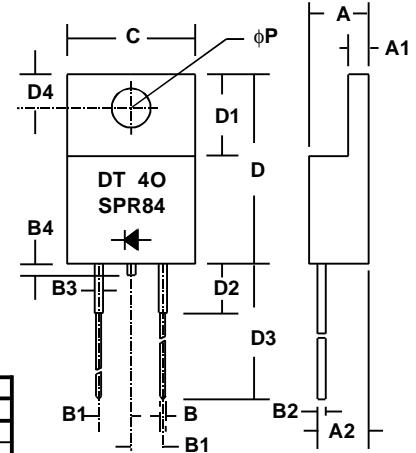

Sym	Minimum		Maximum	
	in	mm	in	mm
A			0.187	4.75
A1	0.121*	4.75*		
A2	0.14*	3.56*		
B	0.035	0.9	0.043	1.1
B1	0.09	2.3	0.102	2.6
B2	0.025*	0.64*		
B3	0.050*	1.27*		
B4			0.04	1.0
C			0.413	10.5
D	0.59	15.0	0.61	15.5
D1	0.262*	6.6*		
D2			0.16	4.0
D3	0.54	13.7	0.60	15.2
D4	0.108*	2.75*		
φP	0.126*	3.2*		

* These dimensions are "Typicals".

TO - 220AC
SERIES SPR81 - SPR86

MAXIMUM RATINGS & ELECTRICAL CHARACTERISTICS

Ratings at 25 °C ambient temperature unless otherwise specified.
 Single phase, half wave, 60Hz, resistive or inductive load.
 For capacitive loads, derate current by 20%.

PARAMETER (TEST CONDITIONS)	SYMBOL	RATINGS						UNITS
		SPR81	SPR82	SPR83	SPR84	SPR85	SPR86	
Series Number								
Maximum DC Blocking Voltage	V _{RM}	100	200	300	400	500	600	VOLTS
Maximum RMS Voltage	V _{RMS}	70	140	210	280	350	420	
Maximum Peak Recurrent Reverse Voltage	V _{RRM}	100	200	300	400	500	600	
Average Forward Rectified Current @ T _c = 110 °C	I _O	8						AMPS
Peak Forward Surge Current (8.3mS single half sine wave superimposed on rated load)	I _{FSM}	125						
Maximum Forward Voltage at 8 Amps DC	V _{FM}	1.0			1.2			VOLTS
Maximum Average DC Reverse Current @ T _c = 25 °C At Rated DC Blocking Voltage @ T _c = 100 °C	I _{RM}	10			500			μA
Typical Thermal Resistance, Junction to Case	R _{θJC}	3						°C/W
Typical Junction Capacitance (Note 1)	C _J	65						pF
Maximum Reverse Recovery Time (I _F =0.5A, I _R =1.0A, I _{RR} =0.25A)	T _{RR}	35			45			nSec
Junction Operating and Storage Temperature Range	T _J , T _{STG}	-65 to +150						°C

NOTES: (1) Measured at 1 MHz and an applied reverse voltage of 4 volts.

4.97100008A

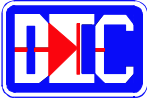

8 AMP SUPER EFFICIENT RECTIFIERS

RATING & CHARACTERISTIC CURVES FOR SERIES SPR81 - SPR86

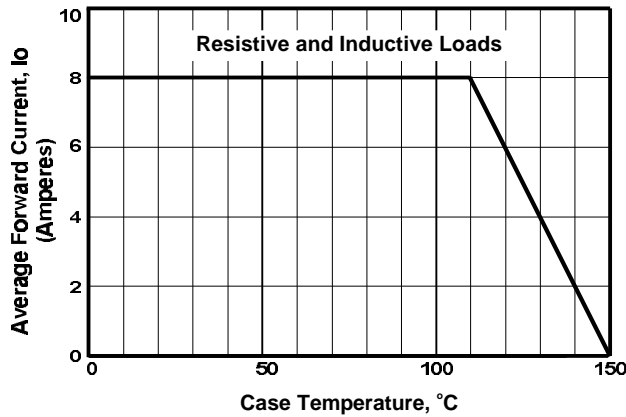

FIGURE 1. FORWARD CURRENT DERATING CURVE

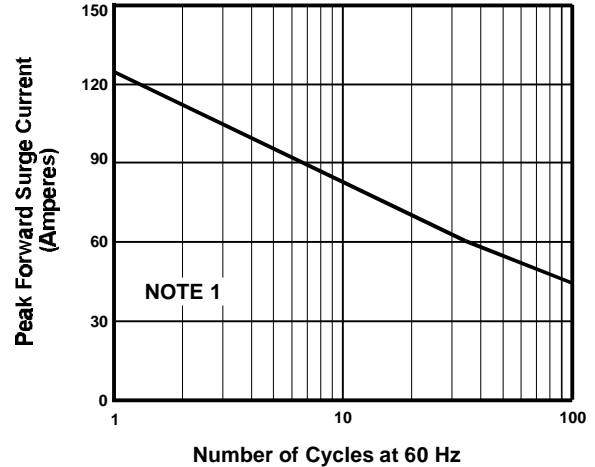

FIGURE 2. MAXIMUM NON-REPETITIVE SURGE CURRENT

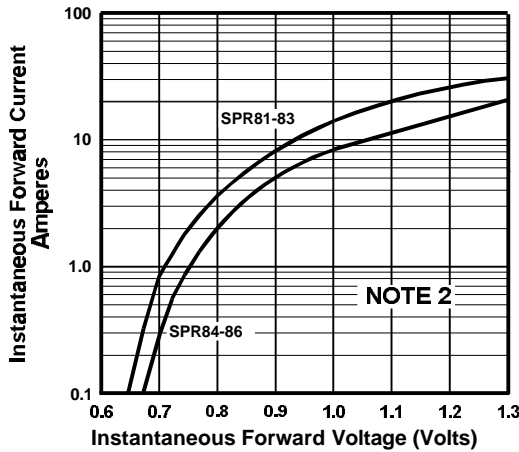

FIGURE 3. TYPICAL FORWARD CHARACTERISTICS

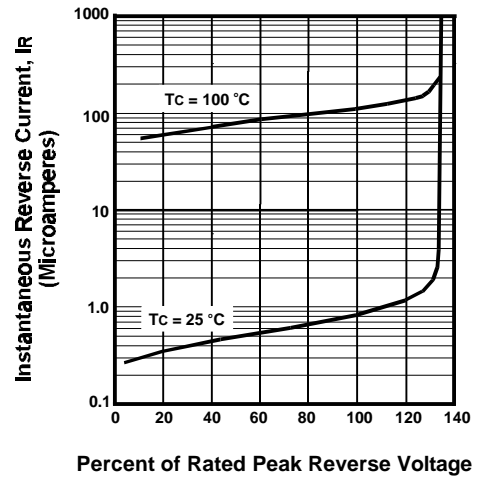

FIGURE 4. TYPICAL REVERSE CHARACTERISTICS

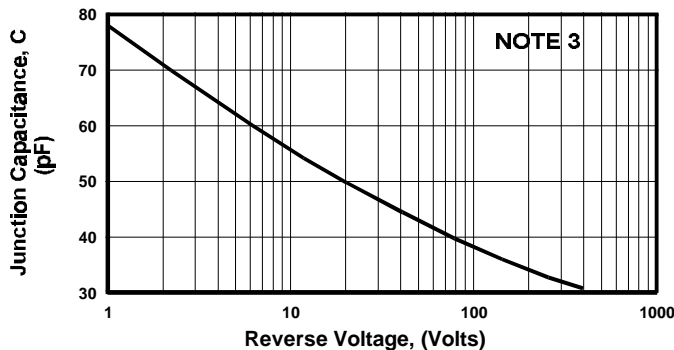
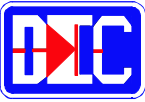

FIGURE 5. TYPICAL JUNCTION CAPACITANCE

NOTES

- (1) JEDEC Method, 8.3 mSec. Single Half Sine Wave
- (2) $T_J = 25^\circ\text{C}$, Pulse Width = 300 μSec , 2.0% Duty Cycle
- (3) $T_C = 25^\circ\text{C}$, $f = 1\text{ MHz}$, $V_{SIG} = 50\text{ mV P-P}$



12 AMP SUPER-EFFICIENT RECTIFIERS

FEATURES

- Glass Passivated for high reliability/temperature performance
- Low switching noise
- Low forward voltage drop
- Low thermal resistance
- High switching capability
- High surge capability

MECHANICAL DATA

- Case: TO-220 molded plastic (Full Insulated) (U/L Flammability Rating 94V-0)
- Terminals: Rectangular pins w/ standoff
- Solderability: Per MIL-STD 202 Method 208 guaranteed
- Polarity: Diode depicted on product
- Mounting Position: Any
- Weight: 0.06 Ounces (1.7 Grams)

MECHANICAL SPECIFICATION

ACTUAL SIZE OF TO-220AC PACKAGE

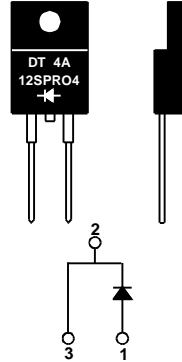

FULLY INSULATED PACKAGE

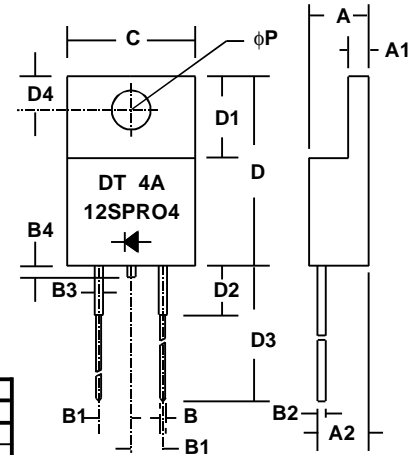

Sym	Minimum		Maximum	
	in	mm	in	mm
A			0.187	4.75
A1	0.121*	4.75*		
A2	0.14*	3.56*		
B	0.035	0.9	0.043	1.1
B1	0.09	2.3	0.102	2.6
B2	0.025*	0.64*		
B3	0.050*	1.27*		
B4			0.04	1.0
C			0.413	10.5
D	0.59	15.0	0.61	15.5
D1	0.262*	6.6*		
D2			0.16	4.0
D3	0.54	13.7	0.60	15.2
D4	0.108*	2.75*		
φP	0.126*	3.2*		

* These dimensions are "Typicals".

ITO - 220AC

SERIES 12SPR01 - 12SPR05

MAXIMUM RATINGS & ELECTRICAL CHARACTERISTICS

Ratings at 25 °C ambient temperature unless otherwise specified.
 Single phase, half wave, 60Hz, resistive or inductive load.
 For capacitive loads, derate current by 20%.

PARAMETER (TEST CONDITIONS)	SYMBOL	RATINGS					UNITS
		12SPR01	12SPR02	12SPR03	12SPR04	12SPR05	
Series Number							
Maximum DC Blocking Voltage	V _{RM}	100	200	300	400	500	VOLTS
Maximum RMS Voltage	V _{RMS}	70	140	210	280	350	
Maximum Peak Recurrent Reverse Voltage	V _{RRM}	100	200	300	400	500	
Average Forward Rectified Current @ T _c = 110 °C	I _O	12					AMPS
Peak Forward Surge Current (8.3mS single half sine wave superimposed on rated load)	I _{FSM}	120					
Maximum Forward Voltage at 12 Amps DC	V _{FM}	1.05		1.20			VOLTS
Maximum Average DC Reverse Current At Rated DC Blocking Voltage	I _{RM}	10					μA
		@ T _c = 25 °C	500				
Typical Thermal Resistance, Junction to Case	R _{θJC}	1.5					°C/W
Typical Junction Capacitance (Note 1)	C _J	45					pF
Maximum Reverse Recovery Time (I _F =8.0A, di/dt=50A/μS, T _J =25°C)	T _{RR}	35		45			nSec
Junction Operating and Storage Temperature Range	T _J , T _{STG}	-65 to +150					°C

NOTES: (1) Measured at 1 MHz and an applied reverse voltage of 4 volts.

4.97100012

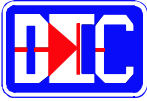

12 AMP SUPER EFFICIENT RECTIFIERS

RATING & CHARACTERISTIC CURVES FOR SERIES 12SPR001 - 12SPR05

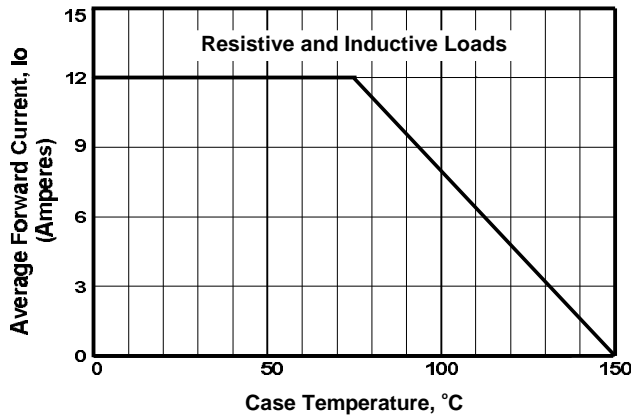

FIGURE 1. FORWARD CURRENT DERATING CURVE

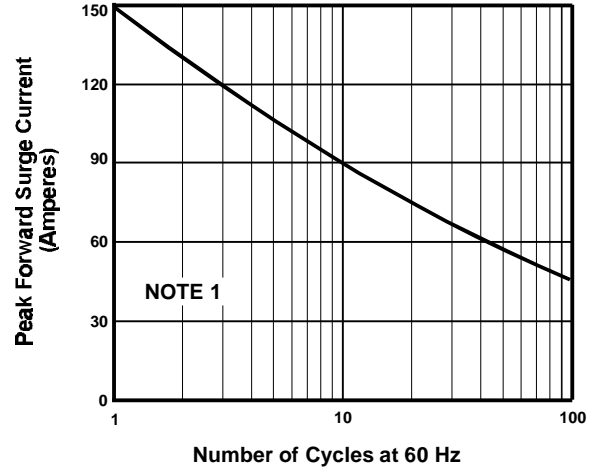

FIGURE 2. MAXIMUM NON-REPETITIVE SURGE CURRENT

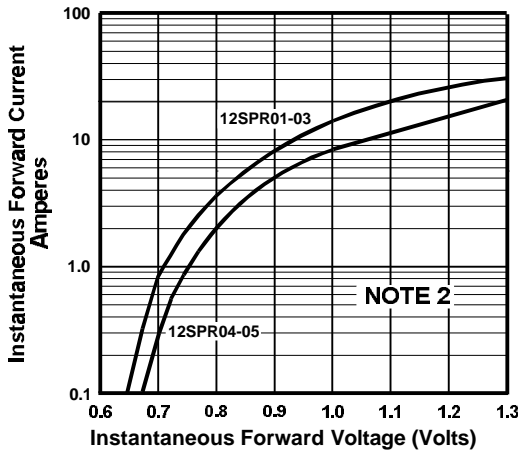

FIGURE 3. TYPICAL FORWARD CHARACTERISTICS

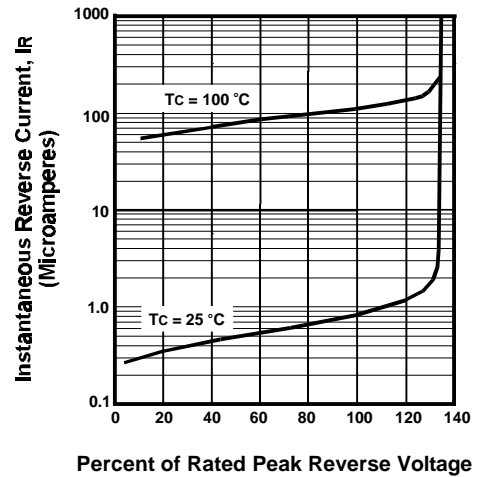

FIGURE 4. TYPICAL REVERSE CHARACTERISTICS

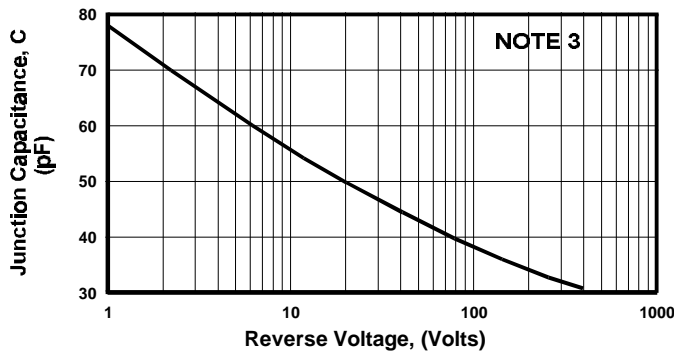
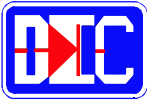

FIGURE 5. TYPICAL JUNCTION CAPACITANCE

NOTES

- (1) JEDEC Method, 8.3 mSec. Single Half Sine Wave
- (2) $T_J = 25^\circ\text{C}$, Pulse Width = 300 μSec , 2.0% Duty Cycle
- (3) $T_C = 25^\circ\text{C}$, $f = 1\text{ MHz}$, $V_{SIG} = 50\text{ mV P-P}$



15 AMP SUPER-EFFICIENT RECTIFIERS

FEATURES

- Glass Passivated for high reliability/temperature performance
- Low switching noise
- Low forward voltage drop
- Low thermal resistance
- High switching capability
- High surge capability

MECHANICAL DATA

- Case: TO-220 molded plastic (U/L Flammability Rating 94V-0)
- Terminals: Rectangular pins w/ standoff
- Solderability: Per MIL-STD 202 Method 208 guaranteed
- Polarity: Diode depicted on product
- Mounting Position: Any
- Weight: 0.08 Ounces (2.2 Grams)

MECHANICAL SPECIFICATION

ACTUAL SIZE OF TO-220AC PACKAGE

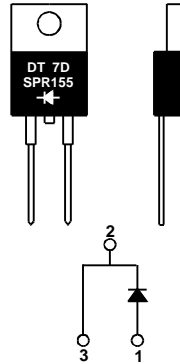

NON - INSULATED PACKAGE

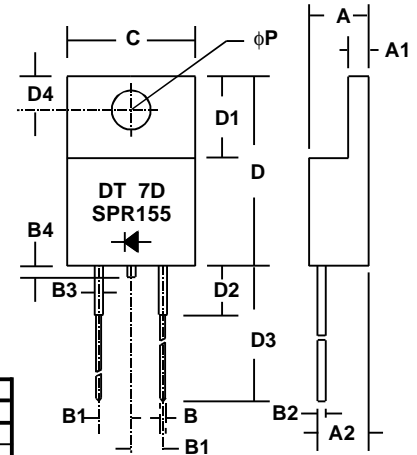

Sym	Minimum		Maximum	
	in	mm	in	mm
A			0.187	4.75
A1	0.121*	4.75*		
A2	0.14*	3.56*		
B	0.035	0.9	0.043	1.1
B1	0.09	2.3	0.102	2.6
B2	0.025*	0.64*		
B3	0.050*	1.27*		
B4			0.04	1.0
C			0.413	10.5
D	0.59	15.0	0.61	15.5
D1	0.262*	6.6*		
D2			0.16	4.0
D3	0.54	13.7	0.60	15.2
D4	0.108*	2.75*		
φP	0.126*	3.2*		

* These dimensions are "Typicals".

TO - 220AC
 SERIES SPR150 - SPR156

MAXIMUM RATINGS & ELECTRICAL CHARACTERISTICS

Ratings at 25 °C ambient temperature unless otherwise specified.
 Single phase, half wave, 60Hz, resistive or inductive load.
 For capacitive loads, derate current by 20%.

PARAMETER (TEST CONDITIONS)	SYMBOL	RATINGS								UNITS
		SPR 150	SPR 151	SPR 152	SPR 153	SPR 154	SPR 155	SPR 156		
Series Number										
Maximum DC Blocking Voltage	V _{RM}	50	100	200	300	400	500	600		VOLTS
Maximum RMS Voltage	V _{RMS}	35	70	140	210	280	350	420		
Maximum Peak Recurrent Reverse Voltage	V _{RRM}	50	100	200	300	400	500	600		
Average Forward Rectified Current @ T _c = 110 °C	I _O	15								AMPS
Peak Forward Surge Current (8.3mS single half sine wave superimposed on rated load)	I _{FSM}	250								
Maximum Forward Voltage at 15 Amps DC	V _{FM}	0.95		1.25		1.5			VOLTS	
Maximum Average DC Reverse Current @ T _c = 25 °C At Rated DC Blocking Voltage @ T _c = 100 °C	I _{RM}	10				500				μA
Typical Thermal Resistance, Junction to Case	R _{θJC}	1.5								°C/W
Typical Junction Capacitance (Note 1)	C _J	65								pF
Maximum Reverse Recovery Time (I _F =0.5A, I _R =1.0A, I _{RR} =0.25A)	T _{RR}	35				50				nSec
Junction Operating and Storage Temperature Range	T _J , T _{STG}	-65 to +150								°C

NOTES: (1) Measured at 1 MHz and an applied reverse voltage of 4 volts.

4.977esaa15

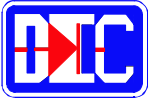

15 AMP SUPER EFFICIENT RECTIFIERS

RATING & CHARACTERISTIC CURVES FOR SERIES SPR150 - SPR156

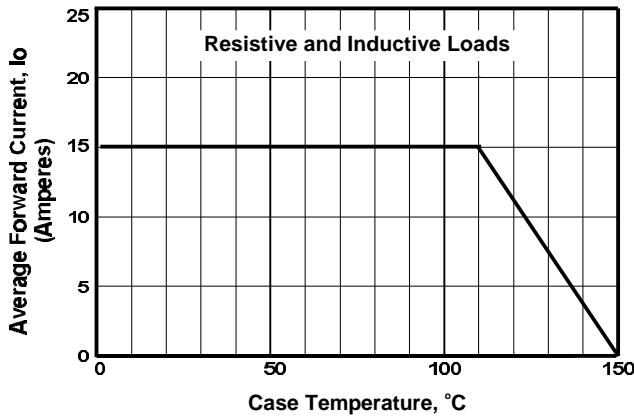

FIGURE 1. FORWARD CURRENT DERATING CURVE

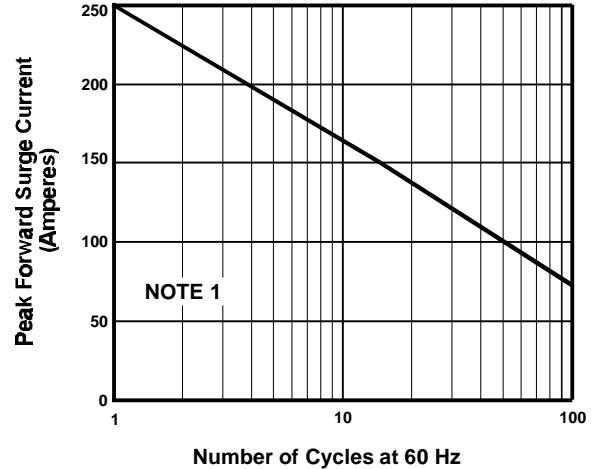

FIGURE 2. MAXIMUM NON-REPETITIVE SURGE CURRENT

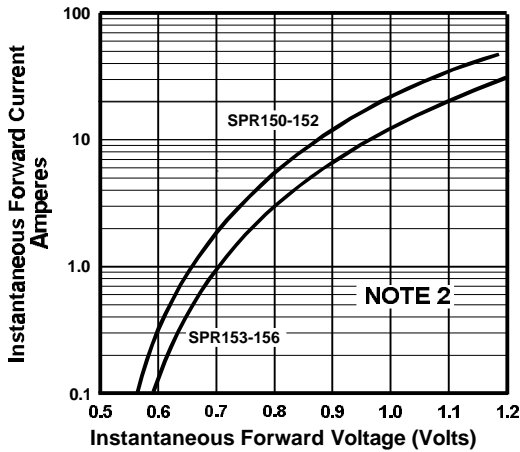

FIGURE 3. TYPICAL FORWARD CHARACTERISTICS

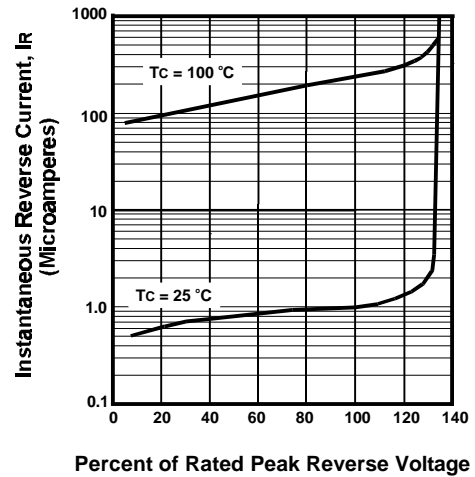

FIGURE 4. TYPICAL REVERSE CHARACTERISTICS

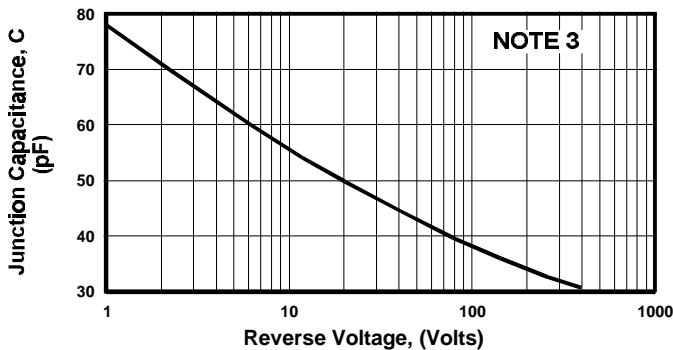

FIGURE 5. TYPICAL JUNCTION CAPACITANCE

NOTES

- (1) JEDEC Method, 8.3 mSec. Single Half Sine Wave
- (2) $T_J = 25^\circ\text{C}$, Pulse Width = 300 μSec , 1.0% Duty Cycle
- (3) $T_C = 25^\circ\text{C}$, $f = 1\text{ MHz}$, $V_{SIG} = 50\text{ mV P-P}$

SECTION D

***SUPER EFFICIENT and
ULTRA FAST RECOVERY
RECTIFIERS
Dual Diode Products***

3 PIN TO-220AB AND TO-247AB PACKAGES

6 TO 30 AMPERES

100 TO 600 VOLTS

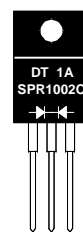

TO - 220AB

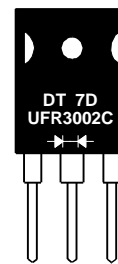

TO - 247AB

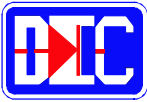

6 AMP SUPER-EFFICIENT RECTIFIERS

FEATURES

- Glass Passivated for high reliability/temperature performance
- Low switching noise
- Low forward voltage drop
- Low thermal resistance
- High switching capability
- High surge capability

MECHANICAL DATA

- Case: TO-220 molded plastic (Fully Insulated) (U/L Flammability Rating 94V-0)
- Terminals: Rectangular pins w/ standoff
- Solderability: Per MIL-STD 202 Method 208 guaranteed
- Polarity: Diodes depicted on product
- Mounting Position: Any
- Weight: 0.06 Ounces (1.75 Grams)

MECHANICAL SPECIFICATION

ACTUAL SIZE OF TO-220AB PACKAGE

FULLY INSULATED PACKAGE

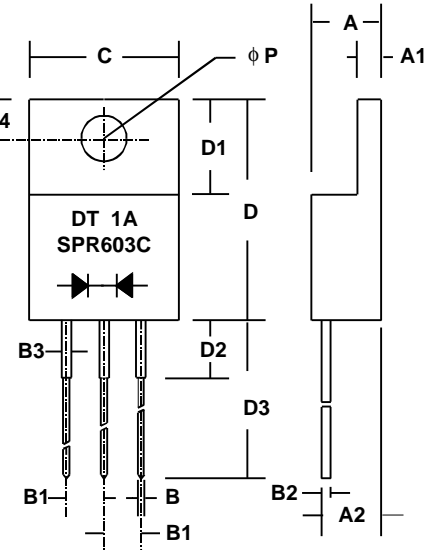
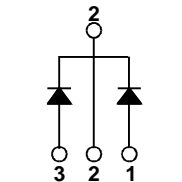
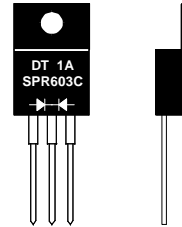

Sym	Minimum		Maximum	
	in	mm	in	mm
A			0.187	4.75
A1	0.055*	1.4*		
A2	0.14*	3.56*		
B	0.035	0.9	0.043	1.1
B1	0.09	2.3	0.102	2.6
B2	0.028*	0.66*		
B3	0.051*	1.3*		
C			0.410	10.4
D	0.59	15.0	0.61	15.5
D1	0.25*	6.4*		
D2			0.16	4.0
D3	0.53	13.5	0.57	14.8
D4	0.108*	2.75*		
phi P	0.141*	3.58*		

* These dimensions are "Typicals".

ITO - 220AB

SERIES SPR601C - SPR605C

MAXIMUM RATINGS & ELECTRICAL CHARACTERISTICS

Ratings at 25 °C ambient temperature unless otherwise specified.
 Single phase, half wave, 60Hz, resistive or inductive load.
 For capacitive loads, derate current by 20%.

PARAMETER (TEST CONDITIONS)	SYMBOL	RATINGS					UNITS
		SPR 601C	SPR 602C	SPR 603C	SPR 604C	SPR 605C	
Series Number							
Maximum DC Blocking Voltage	V _{RM}	100	200	300	400	500	VOLTS
Maximum RMS Voltage	V _{RMS}	70	140	210	280	350	
Maximum Peak Recurrent Reverse Voltage	V _{RRM}	100	200	300	400	500	
Average Forward Rectified Current @ T _c = 120 °C	I _o	6					AMPS
Peak Forward Surge Current (8.3mS single half sine wave superimposed on rated load)	I _{FSM}	60					
Maximum Forward Voltage (per diode) at 3 Amps DC	V _{FM}	1.0		1.25			VOLTS
Maximum Average DC Reverse Current @ T _c = 25 °C At Rated DC Blocking Voltage @ T _c = 100 °C	I _{RM}	10 500					μA
Typical Thermal Resistance, Junction to Case	R _{θJC}	4					°C/W
Typical Junction Capacitance (Note 1)	C _J	65					pF
Maximum Reverse Recovery Time (I _F =3.0A, di/dt=50A/μS, T _J =25°C)	T _{RR}	30					nSec
Junction Operating and Storage Temperature Range	T _J , T _{STG}	-65 to +150					°C

NOTES: (1) Measured at 1 MHz and an applied reverse voltage of 4 volts.

4.971sedr6

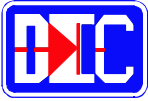

6 AMP SUPER EFFICIENT RECTIFIERS

RATING & CHARACTERISTIC CURVES FOR SERIES SPR601C - SPR605C

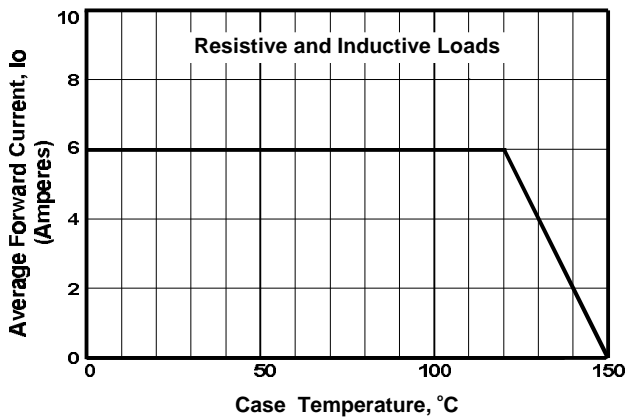

FIGURE 1. FORWARD CURRENT DERATING CURVE

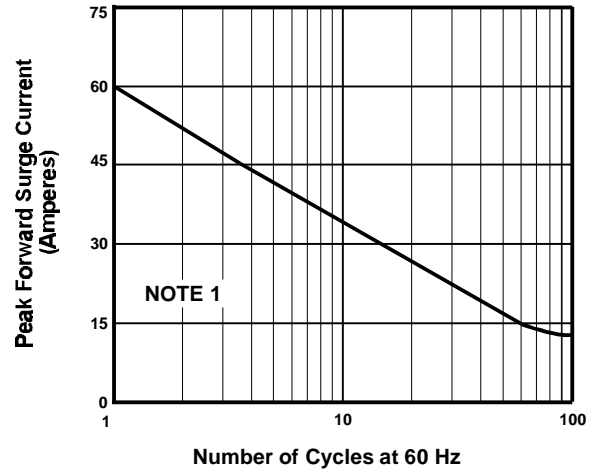

FIGURE 2. MAXIMUM NON-REPETITIVE SURGE CURRENT

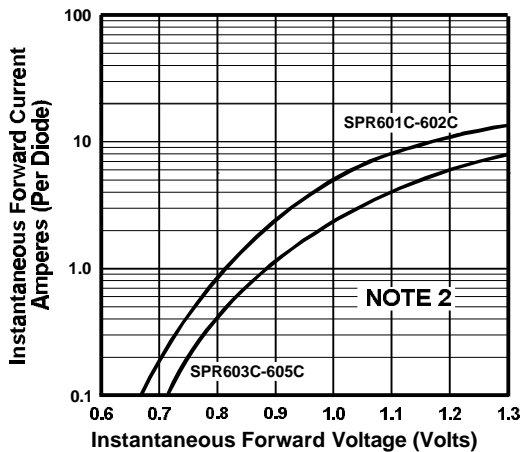

FIGURE 3. TYPICAL FORWARD CHARACTERISTICS

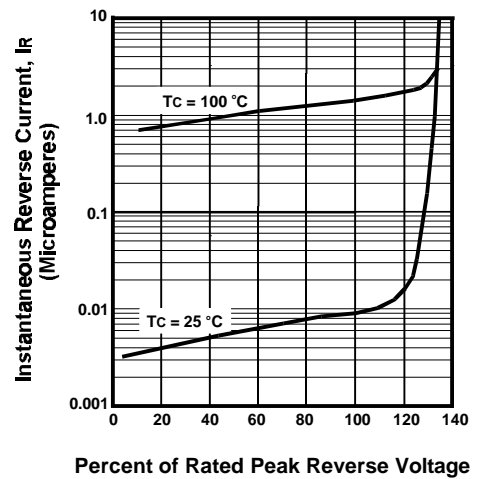

FIGURE 4. TYPICAL REVERSE CHARACTERISTICS

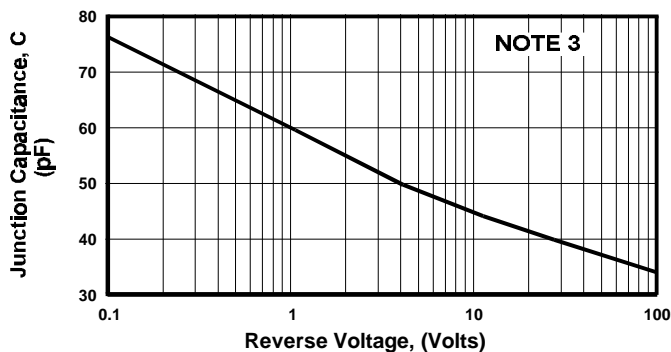
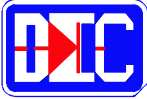

FIGURE 5. TYPICAL JUNCTION CAPACITANCE

NOTES

- (1) JEDEC Method, 8.3 mSec. Single Half Sine Wave
- (2) $T_J = 25^\circ\text{C}$, Pulse Width = 300 μSec , 2.0% Duty Cycle
- (3) $T_C = 25^\circ\text{C}$



10 AMP SUPER-EFFICIENT RECTIFIERS

FEATURES

- Glass Passivated for high reliability/temperature performance
- Low switching noise
- Low forward voltage drop
- Low thermal resistance
- High switching capability
- High surge capability

MECHANICAL DATA

- Case: TO-220 molded plastic (Fully Insulated) (U/L Flammability Rating 94V-0)
- Terminals: Rectangular pins w/ standoff
- Solderability: Per MIL-STD 202 Method 208 guaranteed
- Polarity: Diodes depicted on product
- Mounting Position: Any
- Weight: 0.06 Ounces (1.75 Grams)

MECHANICAL SPECIFICATION

ACTUAL SIZE OF TO-220AB PACKAGE

FULLY INSULATED PACKAGE

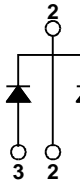
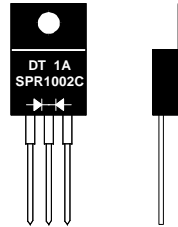

Sym	Minimum		Maximum	
	in	mm	in	mm
A			0.187	4.75
A1	0.055*	1.4*		
A2	0.14*	3.56*		
B	0.035	0.9	0.043	1.1
B1	0.09	2.3	0.102	2.6
B2	0.028*	0.66*		
B3	0.051*	1.3*		
C			0.410	10.4
D	0.59	15.0	0.61	15.5
D1	0.25*	6.4*		
D2			0.16	4.0
D3	0.53	13.5	0.57	14.8
D4	0.108*	2.75*		
φP	0.141*	3.58*		

* These dimensions are "Typicals".

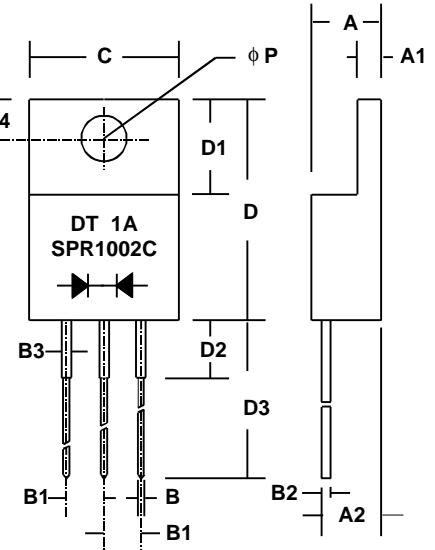

ITO - 220AB

SERIES SPR1001C - SPR1005C

MAXIMUM RATINGS & ELECTRICAL CHARACTERISTICS

Ratings at 25 °C ambient temperature unless otherwise specified.
 Single phase, half wave, 60Hz, resistive or inductive load.
 For capacitive loads, derate current by 20%.

PARAMETER (TEST CONDITIONS)	SYMBOL	RATINGS					UNITS
		SPR 1001C	SPR 1002C	SPR 1003C	SPR 1004C	SPR 1005C	
Series Number							
Maximum DC Blocking Voltage	V _{RM}	100	200	300	400	500	VOLTS
Maximum RMS Voltage	V _{RMS}	70	140	210	280	350	
Maximum Peak Recurrent Reverse Voltage	V _{RRM}	100	200	300	400	500	
Average Forward Rectified Current @ T _c = 120 °C	I _o	10					AMPS
Peak Forward Surge Current (8.3mS single half sine wave superimposed on rated load)	I _{FSM}	100					
Maximum Forward Voltage (per diode) at 5 Amps DC	V _{FM}	1.0		1.25			VOLTS
Maximum Average DC Reverse Current @ T _c = 25 °C At Rated DC Blocking Voltage @ T _c = 100 °C	I _{RM}	10 500					μA
Typical Thermal Resistance, Junction to Case	R _{θJC}	3					°C/W
Typical Junction Capacitance (Note 1)	C _J	65					pF
Maximum Reverse Recovery Time (I _F =5.0A, di/dt=50A/μS, T _J =25°C)	T _{RR}	35		45			nSec
Junction Operating and Storage Temperature Range	T _J , T _{STG}	-65 to +150					°C

NOTES: (1) Measured at 1 MHz and an applied reverse voltage of 4 volts.

4.97sedr10

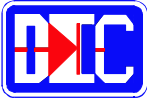

10 AMP SUPER EFFICIENT RECTIFIERS

RATING & CHARACTERISTIC CURVES FOR SERIES SPR1001C - SPR1005C

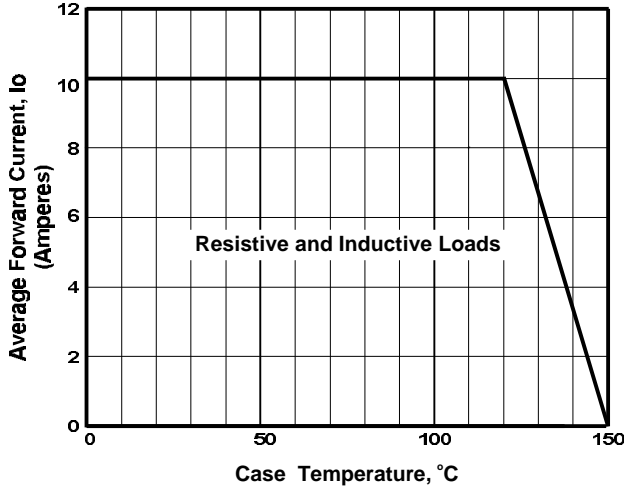

FIGURE 1. FORWARD CURRENT DERATING CURVE

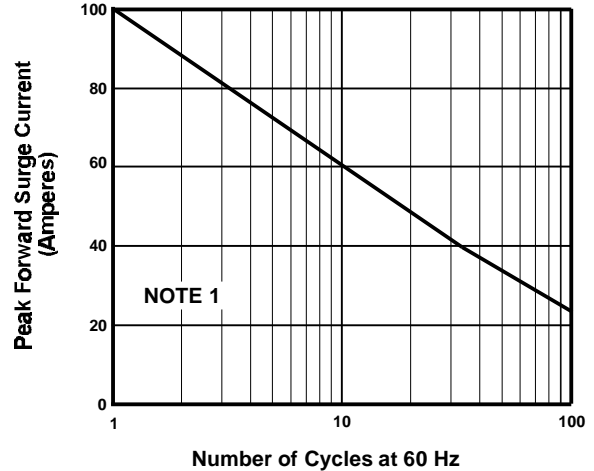

FIGURE 2. MAXIMUM NON-REPETITIVE SURGE CURRENT

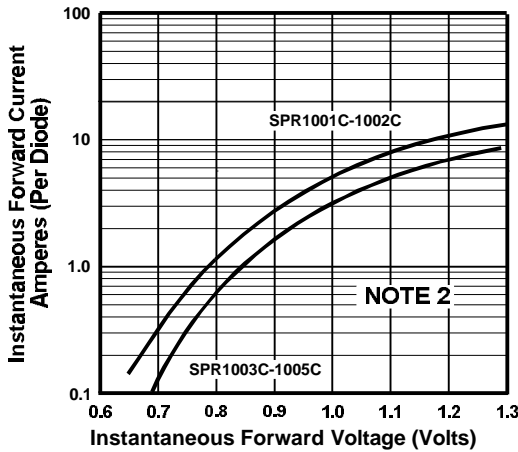

FIGURE 3. TYPICAL FORWARD CHARACTERISTICS

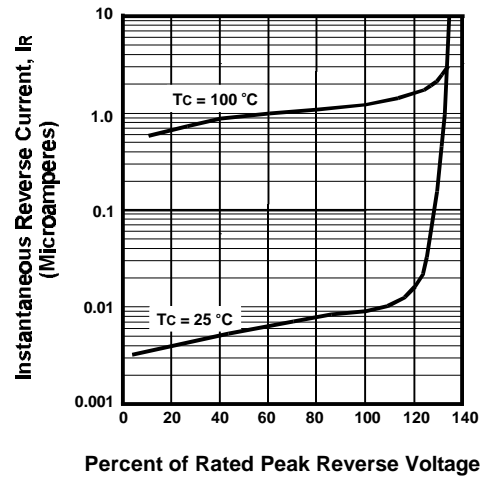

FIGURE 4. TYPICAL REVERSE CHARACTERISTICS

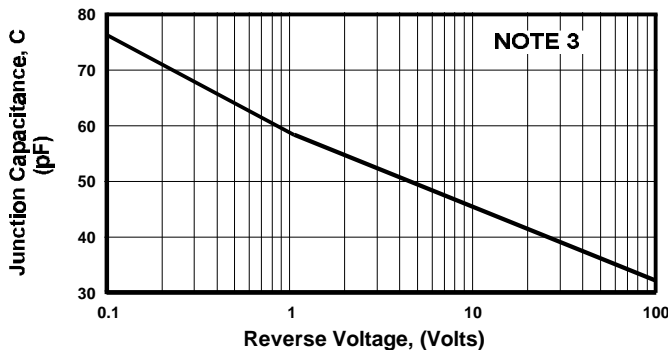
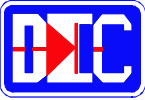

FIGURE 5. TYPICAL JUNCTION CAPACITANCE

NOTES

- (1) JEDEC Method, 8.3 mSec. Single Half Sine Wave
- (2) $T_J = 25^\circ\text{C}$, Pulse Width = 300 μSec , 2.0% Duty Cycle
- (3) $T_J = 25^\circ\text{C}$



16 AMP SUPER-EFFICIENT RECTIFIERS

FEATURES

- Glass Passivated for high reliability/temperature performance
- Low switching noise
- Low forward voltage drop
- Low thermal resistance
- High switching capability
- High surge capability

MECHANICAL DATA

- Case: TO-220 molded plastic- Fully Insulated (U/L Flammability Rating 94V-0)
- Terminals: Rectangular pins w/ standoff
- Solderability: Per MIL-STD 202 Method 208 guaranteed
- Polarity: Diodes depicted on product
- Mounting Position: Any
- Weight: 0.08 Ounces (2.2 Grams)

MECHANICAL SPECIFICATION

ACTUAL SIZE OF TO-220AB PACKAGE

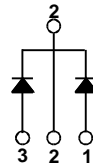
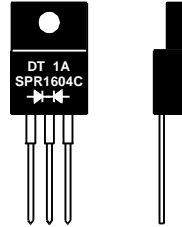

Sym	Minimum		Maximum	
	in	mm	in	mm
A			0.187	4.75
A1	0.055*	1.4*		
A2	0.14*	3.56*		
B	0.035	0.9	0.043	1.1
B1	0.09	2.3	0.102	2.6
B2	0.029*	0.66*		
B3	0.051*	1.3*		
C			0.410	10.4
D	0.59	15.0	0.61	15.5
D1	0.25*	6.4*		
D2			0.16	4.0
D3	0.53	13.5	0.57	14.8
D4	0.108*	2.75*		
φP	0.141*	3.58*		

* These dimensions are "Typicals".

FULLY INSULATED PACKAGE

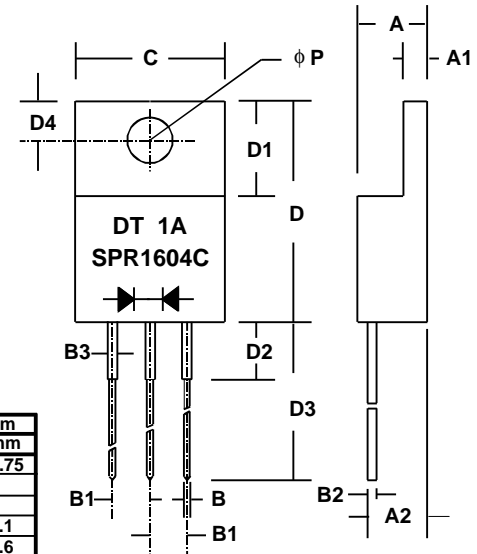

TO - 220AB

SERIES SPR1601C - SPR1605C

MAXIMUM RATINGS & ELECTRICAL CHARACTERISTICS

Ratings at 25 °C ambient temperature unless otherwise specified.
 Single phase, half wave, 60Hz, resistive or inductive load.
 For capacitive loads, derate current by 20%.

PARAMETER (TEST CONDITIONS)	SYMBOL	RATINGS					UNITS
		SPR 1601C	SPR 1602C	SPR 1603C	SPR 1604C	SPR 1605C	
Series Number							
Maximum DC Blocking Voltage	V _{RM}	100	200	300	400	500	VOLTS
Maximum RMS Voltage	V _{RMS}	70	140	210	280	350	
Maximum Peak Recurrent Reverse Voltage	V _{RRM}	100	200	300	400	500	
Average Forward Rectified Current @ T _c = 100 °C	I _o	16					AMPS
Peak Forward Surge Current (8.3mS single half sine wave superimposed on rated load)	I _{FSM}	150					
Maximum Forward Voltage (per diode) at 8 Amps DC	V _{FM}	1.0		1.2			VOLTS
Maximum Average DC Reverse Current @ T _c = 25 °C At Rated DC Blocking Voltage @ T _c = 100 °C	I _{RM}	10 500					μA
Typical Thermal Resistance, Junction to Case	R _{θJC}	3					°C/W
Typical Junction Capacitance (Note 1)	C _J	65					pF
Maximum Reverse Recovery Time (I _F =8.0A, di/dt=50A/μS, T _J =25°C)	T _{RR}	35			45		nSec
Junction Operating and Storage Temperature Range	T _J , T _{STG}	-65 to +150					°C

NOTES: (1) Measured at 1 MHz and an applied reverse voltage of 4 volts.

7.95SPR1601C

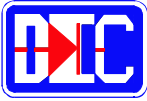

16 AMP SUPER EFFICIENT RECTIFIERS

RATING & CHARACTERISTIC CURVES FOR SERIES SPR1601C - SPR1605C

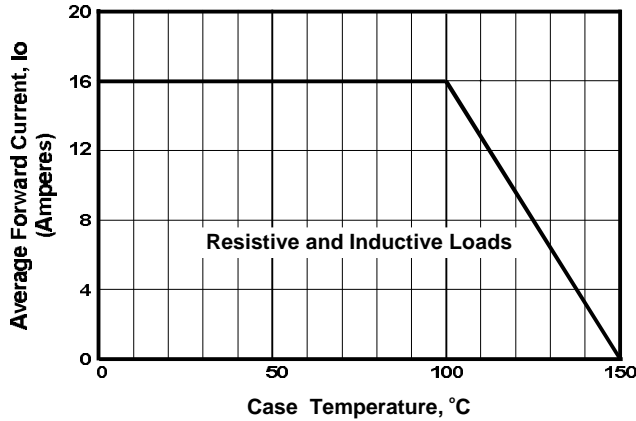

FIGURE 1. FORWARD CURRENT DERATING CURVE

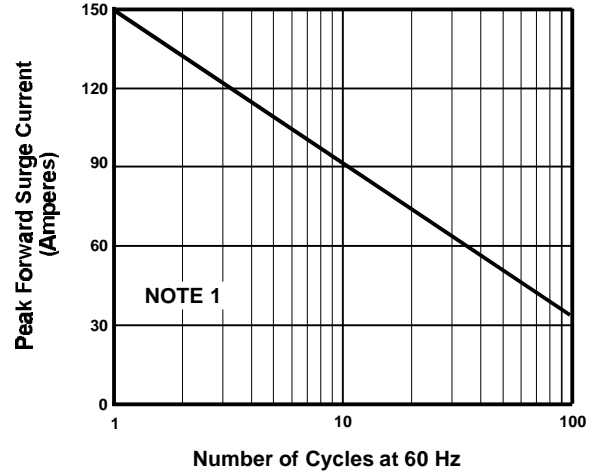

FIGURE 2. MAXIMUM NON-REPETITIVE SURGE CURRENT

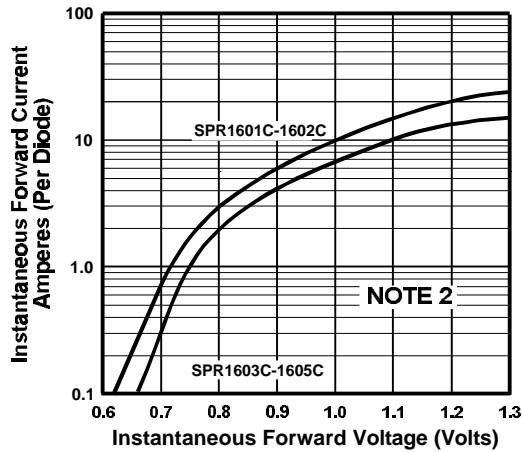

FIGURE 3. TYPICAL FORWARD CHARACTERISTICS

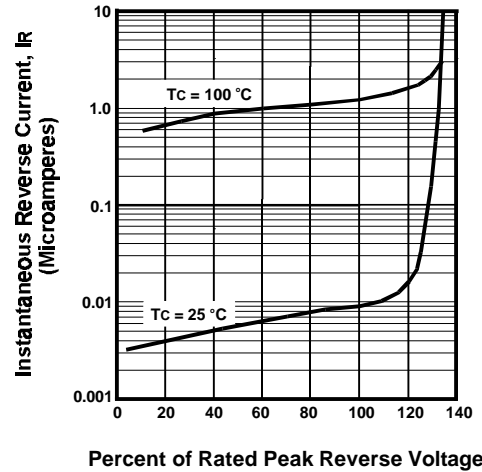

FIGURE 4. TYPICAL REVERSE CHARACTERISTICS

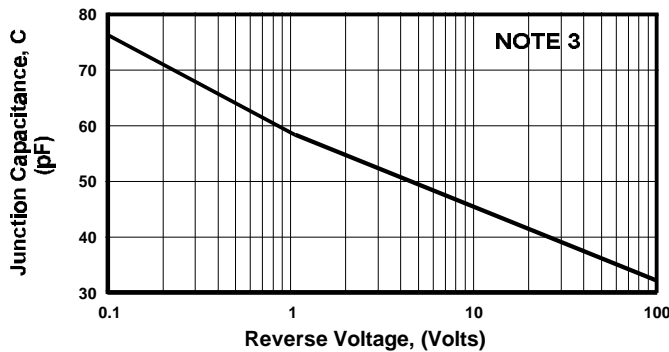
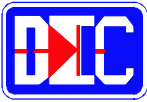

FIGURE 5. TYPICAL JUNCTION CAPACITANCE

NOTES

- (1) JEDEC Method, 8.3 mSec. Single Half Sine Wave
- (2) $T_J = 25^\circ\text{C}$, Pulse Width = 300 μSec , 2.0% Duty Cycle
- (3) $T_J = 25^\circ\text{C}$



16 AMP SUPER-EFFICIENT RECTIFIERS

FEATURES

- Glass Passivated for high reliability/temperature performance
- Low switching noise
- Low forward voltage drop
- Low thermal resistance
- High switching capability
- High surge capability

MECHANICAL DATA

- Case: TO-220 molded plastic (U/L Flammability Rating 94V-0)
- Terminals: Rectangular pins w/ standoff
- Solderability: Per MIL-STD 202 Method 208 guaranteed
- Polarity: Diodes depicted on product
- Mounting Position: Any
- Weight: 0.08 Ounces (2.2 Grams)

MECHANICAL SPECIFICATION

ACTUAL SIZE OF TO-220AB PACKAGE

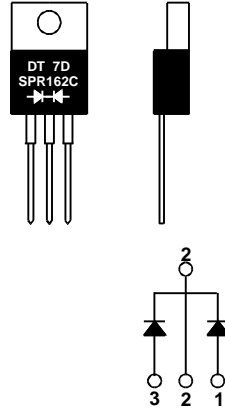

NON - INSULATED PACKAGE

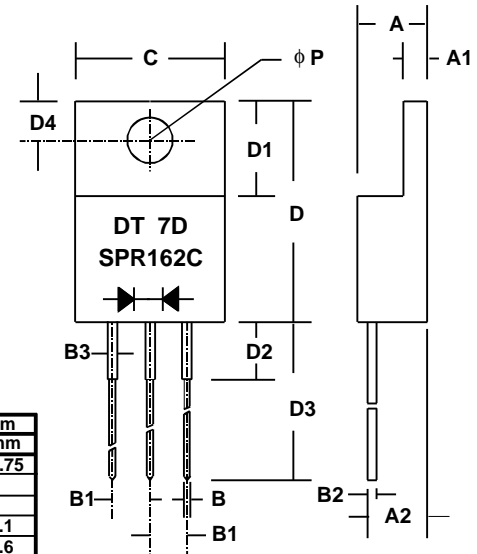

Sym	Minimum		Maximum	
	in	mm	in	mm
A			0.187	4.75
A1	0.055*	1.4*		
A2	0.14*	3.56*		
B	0.035	0.9	0.043	1.1
B1	0.09	2.3	0.102	2.6
B2	0.028*	0.66*		
B3	0.051*	1.3*		
C			0.410	10.4
D	0.59	15.0	0.61	15.5
D1	0.25*	6.4*		
D2			0.16	4.0
D3	0.53	13.5	0.57	14.8
D4	0.108*	2.75*		
phi P	0.141*	3.58*		

* These dimensions are "Typicals".

TO - 220AB

SERIES SPR161C - SPR166C

MAXIMUM RATINGS & ELECTRICAL CHARACTERISTICS

Ratings at 25 °C ambient temperature unless otherwise specified.
 Single phase, half wave, 60Hz, resistive or inductive load.
 For capacitive loads, derate current by 20%.

PARAMETER (TEST CONDITIONS)	SYMBOL	RATINGS						UNITS
		SPR 161C	SPR 162C	SPR 163C	SPR 164C	SPR 165C	SPR 166C	
Series Number								
Maximum DC Blocking Voltage	VRM	100	200	300	400	500	600	VOLTS
Maximum RMS Voltage	VRMS	70	140	210	280	350	420	
Maximum Peak Recurrent Reverse Voltage	VRRM	100	200	300	400	500	600	
Average Forward Rectified Current @ Tc = 100 °C	Io	16						AMPS
Peak Forward Surge Current (8.3mS single half sine wave superimposed on rated load)	IFSM	200						
Maximum Forward Voltage at 8 Amps DC	VFM	0.975	1.3		1.5			VOLTS
Maximum Average DC Reverse Current @ Tc = 25 °C At Rated DC Blocking Voltage @ Tc = 100 °C	IRM	10				500		µA
Typical Thermal Resistance, Junction to Case	RθJC	3						°C/W
Typical Junction Capacitance (Note 1)	CJ	65						pF
Maximum Reverse Recovery Time (If=0.5A, Ir=1.0A, IRR=0.25A)	TRR	35		50				nSec
Junction Operating and Storage Temperature Range	TJ, TSTG	-65 to +150						°C

NOTES: (1) Measured at 1 MHz and an applied reverse voltage of 4 volts.

4.970ed16c

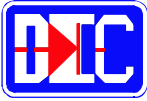

16 AMP SUPER EFFICIENT RECTIFIERS

RATING & CHARACTERISTIC CURVES FOR SERIES SPR161C - SPR166C

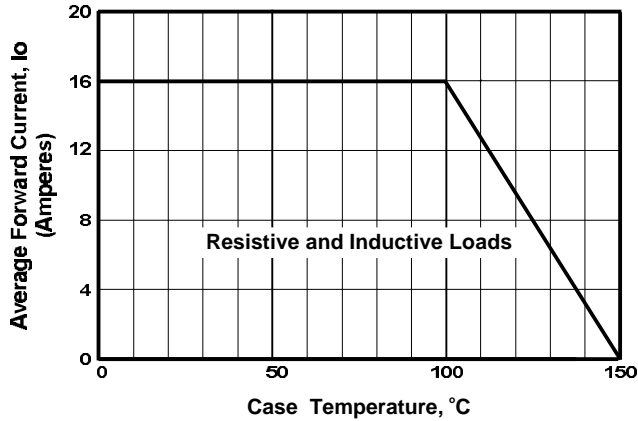

FIGURE 1. FORWARD CURRENT DERATING CURVE

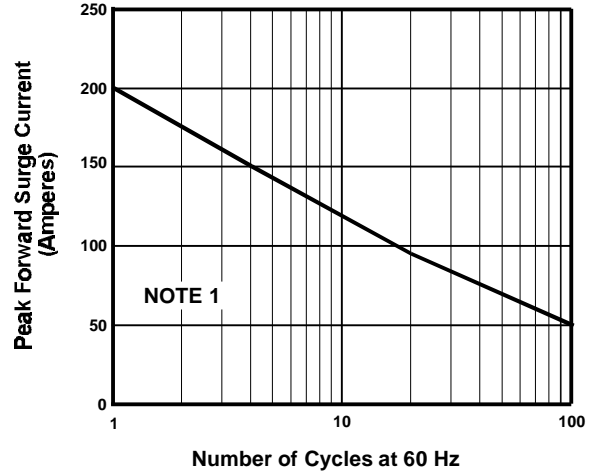

FIGURE 2. MAXIMUM NON-REPETITIVE SURGE CURRENT

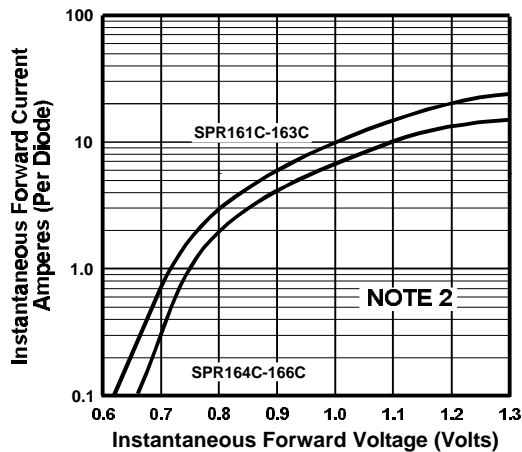

FIGURE 3. TYPICAL FORWARD CHARACTERISTICS

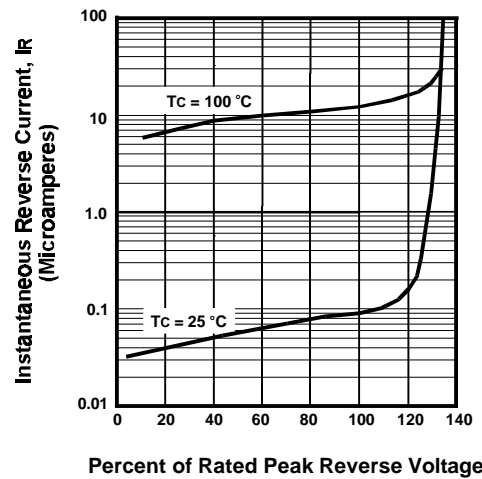

FIGURE 4. TYPICAL REVERSE CHARACTERISTICS

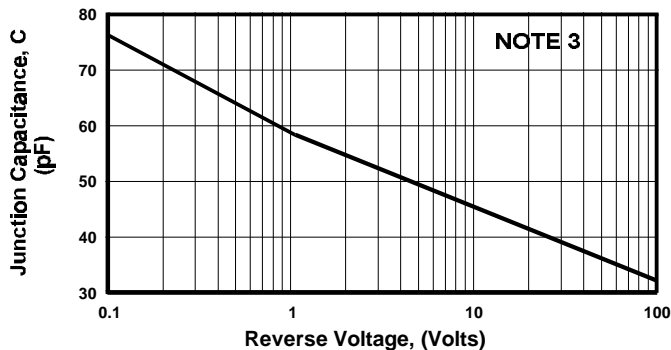
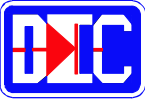

FIGURE 5. TYPICAL JUNCTION CAPACITANCE

NOTES

- (1) JEDEC Method, 8.3 mSec. Single Half Sine Wave
- (2) $T_J = 25^\circ\text{C}$, Pulse Width = 300 μSec , 2.0% Duty Cycle
- (3) $T_J = 25^\circ\text{C}$



30 AMP ULTRAFAST RECOVERY DIODES

FEATURES

- Glass Passivated for high reliability/temperature performance
- Low switching noise
- Low forward voltage drop
- Low thermal resistance
- High switching capability
- High surge capability

MECHANICAL DATA

- Case: TO-247(TO-3P) molded plastic (U/L Flammability Rating 94V-0)
- Terminals: Rectangular pins w/ standoff
- Solderability: Per MIL-STD 202 Method 208 guaranteed
- Polarity: Diodes depicted on product
- Mounting Position: Any
- Weight: 0.2 Ounces (5.55 Grams)

MECHANICAL SPECIFICATION

ACTUAL SIZE OF TO-247AB (TO-3PAB) PACKAGE

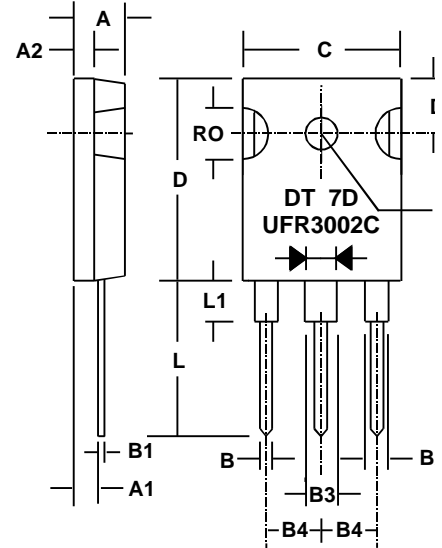
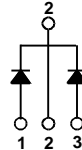
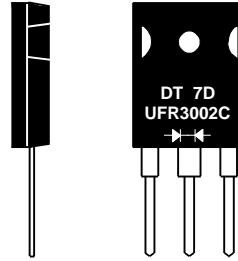

*Applies to Pins 1 and 3

Sym	Minimum		Maximum	
	in	mm	in	mm
A	0.19	4.82	0.205	5.2
A1	0.087	2.21	0.102	2.6
A2	0.075	1.9	0.085	2.16
B	0.045	1.14	0.055	1.4
B1	0.022	0.56	0.032	0.81
B2	0.079	2.01	0.094	2.39
B3	0.116	2.95	0.126	3.2
B4			0.215	5.46
C	0.602	15.29	0.625	15.88
D	0.776	19.7	0.799	20.3
D1	0.209	5.31	0.224	5.69
L	0.559	14.2	0.582	14.8
L1	0.146	3.71	0.189	4.8
RO	0.209	5.3	0.224	5.7
φP	0.13	3.3	0.145	3.7

TO-247AB (TO-3PAB)

SERIES UFR3001C - UFR3005C

MAXIMUM RATINGS & ELECTRICAL CHARACTERISTICS

Ratings at 25 °C ambient temperature unless otherwise specified.
 Single phase, half wave, 60Hz, resistive or inductive load.
 For capacitive loads, derate current by 20%.

PARAMETER (TEST CONDITIONS)	SYMBOL	RATINGS					UNITS
		UFR 3001C	UFR 3002C	UFR 3003C	UFR 3004C	UFR 3005C	
Series Number							
Maximum DC Blocking Voltage	V _{RM}	100	200	300	400	500	VOLTS
Maximum RMS Voltage	V _{RMS}	70	140	210	280	350	
Maximum Peak Recurrent Reverse Voltage	V _{RRM}	100	200	300	400	500	
Average Forward Rectified Current @ T _c = 100 °C	I _o	30					AMPS
Peak Forward Surge Current (8.3mS single half sine wave superimposed on rated load)	I _{FSM}	250		200			
Maximum Forward Voltage (per diode) at 15 Amps DC	V _{FM}	1.0		1.25			VOLTS
Maximum Average DC Reverse Current @ T _c = 25 °C At Rated DC Blocking Voltage @ T _c = 100 °C	I _{RM}	10			500		μA
Typical Thermal Resistance, Junction to Case	R _{θJC}	2					°C/W
Typical Junction Capacitance (Note 1)	C _J	150					pF
Maximum Reverse Recovery Time (I _F =15.0A, di/dt=50A/μS, T _J =25°C)	T _{RR}	50		60			nSec
Junction Operating and Storage Temperature Range	T _J , T _{STG}	-65 to +150					°C

NOTES: (1) Measured at 1 MHz and an applied reverse voltage of 4 volts.

4.975edr10

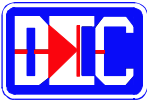

30 AMP ULTRAFAST RECOVERY DIODES

RATING & CHARACTERISTIC CURVES FOR SERIES UFR3001C - UFR3005C

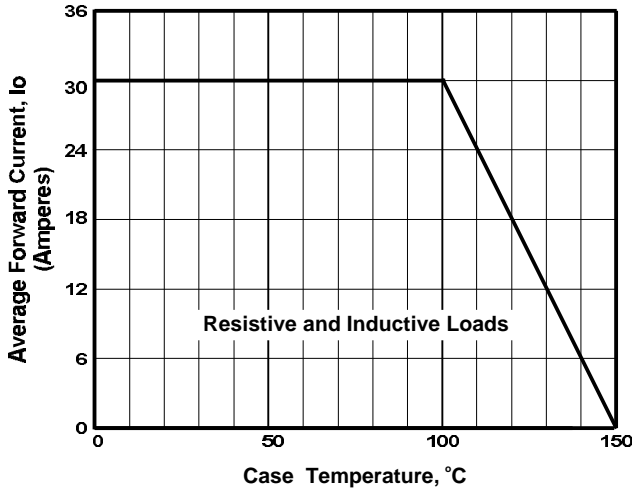

FIGURE 1. FORWARD CURRENT DERATING CURVE

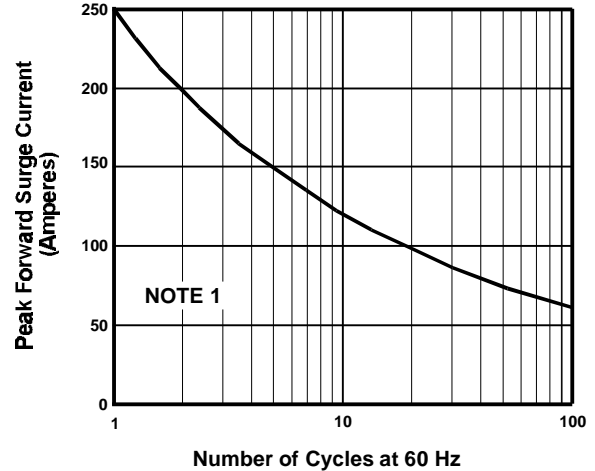

FIGURE 2. MAXIMUM NON-REPETITIVE SURGE CURRENT

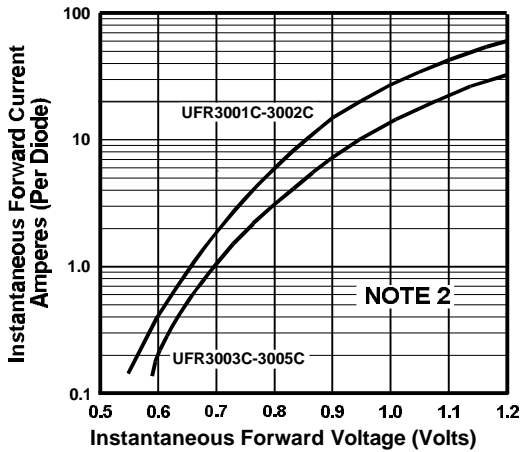

FIGURE 3. TYPICAL FORWARD CHARACTERISTICS

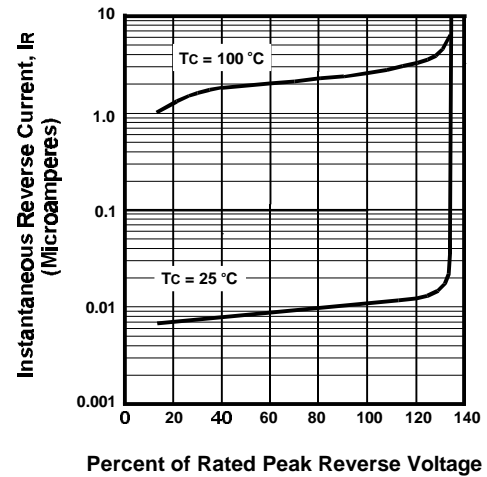

FIGURE 4. TYPICAL REVERSE CHARACTERISTICS

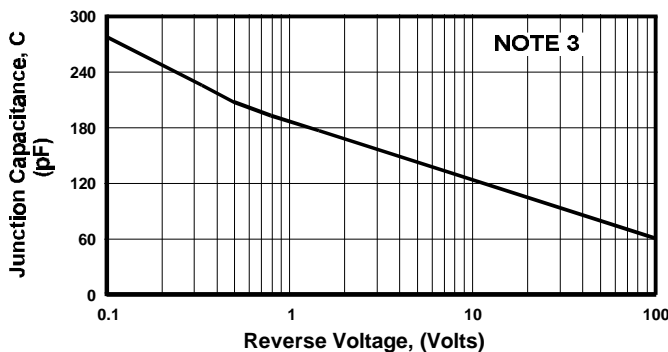

FIGURE 5. TYPICAL JUNCTION CAPACITANCE

NOTES

- (1) JEDEC Method, 8.3 mSec. Single Half Sine Wave
- (2) $T_J = 25^\circ\text{C}$, Pulse Width = 300 μSec , 2.0% Duty Cycle
- (3) $T_C = 25^\circ\text{C}$, $f = 1\text{ MHz}$, $V_{SIG} = 50\text{ mV P-P}$

SECTION E

STANDARD RECOVERY FULL WAVE BRIDGE RECTIFIERS

DUAL IN-LINE PACKAGE

1 AMPERE
50 to 1000 VOLTS



CYLINDRICAL PACKAGE

1 to 2 AMPERES
50 to 1000 VOLTS



VERTICAL, SIDE LOOKING, PACKAGE

2 to 50 AMPERES
50 to 1000 VOLTS

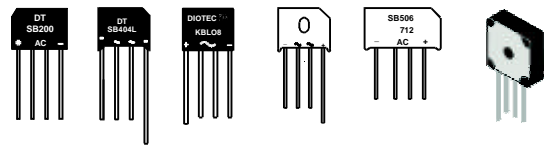

RECTANGULAR HORIZONTAL PACKAGE

3 to 10 AMPERES
50 to 1000 VOLTS



RECTANGULAR HORIZONTAL PACKAGES

15 to 50 AMPERES
50 to 1000 VOLTS

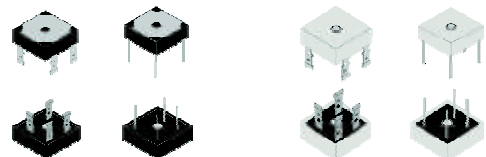

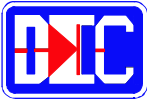

1 AMP MINIATURE BRIDGE RECTIFIERS

FEATURES

- PRV Ratings from 50 to 1000 Volts
- Surge overload rating to 50 Amps peak
- Reliable low cost molded plastic construction
- Ideal for printed circuit board applications

UL RECOGNIZED - FILE #E124962

MECHANICAL DATA

- Case: Molded plastic, U/L Flammability Rating 94V-0
- Terminals: Rectangular pins
- Soldering: Per MIL-STD 202 Method 208 guaranteed
- Polarity: Marked on case
- Mounting Position: Any
- Weight: 0.05 Ounces (1.3 Grams)

MECHANICAL SPECIFICATION

ACTUAL SIZE OF THE DI PACKAGE

SERIES DI100 - DI110

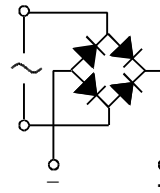
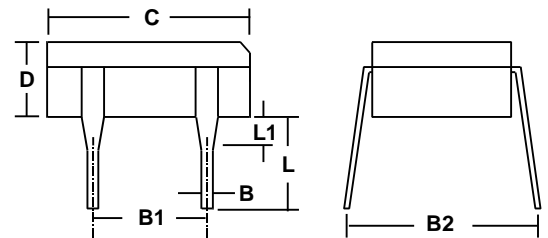
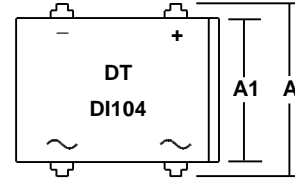
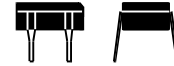

Sym	Minimum		Maximum	
	in	mm	in	mm
A	0.290	7.4	0.310	7.9
A1	0.245	6.2	0.255	6.5
B	0.016	0.41	0.020	0.51
B1	0.195	5.0	0.205	5.2
B2	0.300	7.6	0.350	8.9
C	0.355	9.3	0.365	9.3
D	0.125	3.2	0.135	3.4
L	0.155	3.9	0.165	4.3
L1	0.060*	1.5*		

* This dimension is "Typical".

MAXIMUM RATINGS & ELECTRICAL CHARACTERISTICS

Ratings at 25 °C ambient temperature unless otherwise specified.
 Single phase, half wave, 60Hz, resistive or inductive load.
 For capacitive loads, derate current by 20%.

PARAMETER (TEST CONDITIONS)	SYMBOL	RATINGS							UNITS
		DI100	DI101	DI102	DI104	DI106	DI108	DI110	
Series Number									
Maximum DC Blocking Voltage	V _{RM}	50	100	200	400	600	800	1000	VOLTS
Maximum RMS Voltage	V _{RMS}	35	70	140	280	420	560	700	
Maximum Peak Recurrent Reverse Voltage	V _{RRM}	50	100	200	400	600	800	1000	
Average Forward Rectified Current @ T _A = 40° C	I _O	1							AMPS
Peak Forward Surge Current. Single 60Hz Half-Sine Wave Superimposed on Rated Load (JEDEC Method).	I _{FSM}	50							
Maximum Forward Voltage (Per Diode) at 1 Amp DC	V _{FM}	1.1							VOLTS
Maximum Average DC Reverse Current @ T _A = 25° C	I _{RM}	5.0							μA
At Rated DC Blocking Voltage @ T _A = 100° C		0.5							
Typical Thermal Resistance Junction to Ambient (Note 1)	R _{θJA}	40							°C/W
Junction to Lead (Note 1)	R _{θJL}	15							
Operating and Storage Temperature Range	T _J , T _{STG}	-55 to +150							°C

NOTES: (1) Bridge mounted on PC Board with 0.5" sq. (13 mm sq.) copper pads

3.01 01a

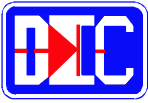

1 AMP MINIATURE BRIDGE RECTIFIERS

RATING & CHARACTERISTIC CURVES FOR SERIES DI100 - DI110

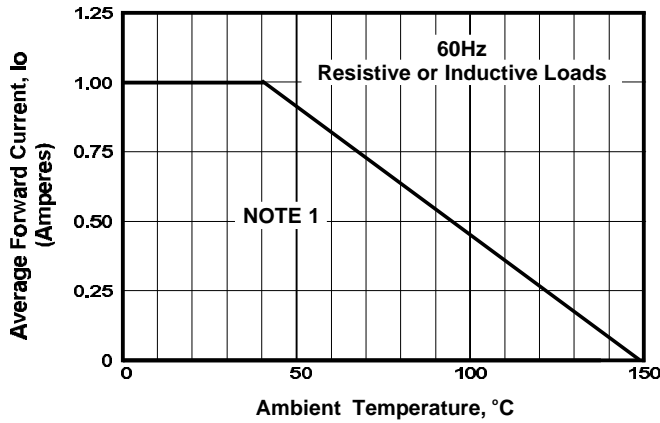

FIGURE 1. FORWARD CURRENT DERATING CURVE

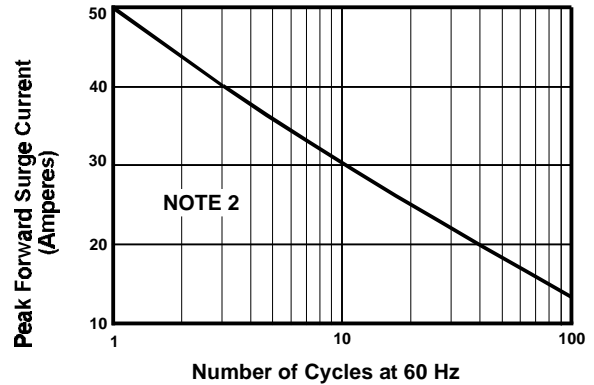

FIGURE 2. MAXIMUM NON-REPETITIVE SURGE CURRENT

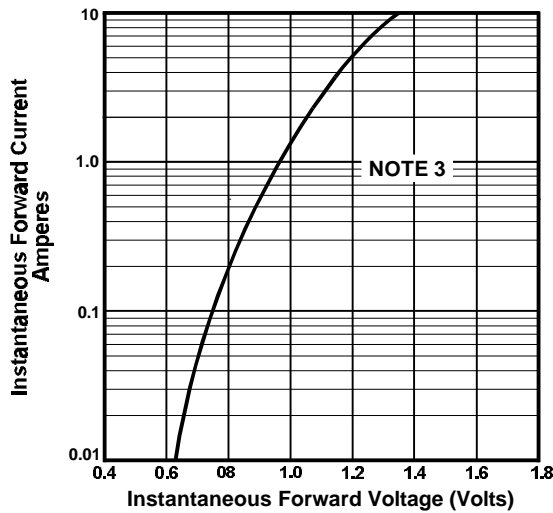

FIGURE 3. TYPICAL FORWARD CHARACTERISTIC PER DIODE

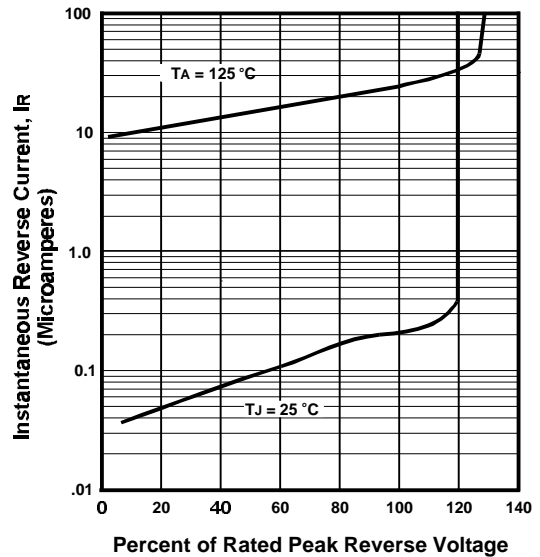

FIGURE 4. TYPICAL REVERSE CHARACTERISTICS

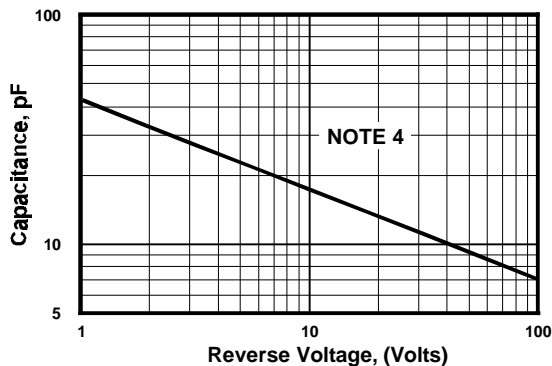

FIGURE 5. TYPICAL JUNCTION CAPACITANCE PER DIODE

NOTES

- (1) Mounted on PC Board With 0.5" Sq. (13 mm Sq.) Copper Pads And Bridge Lead Length of 0.06" (1.5 mm)
- (2) $T_J = 150^\circ\text{C}$
- (3) $T_J = 25^\circ\text{C}$; Pulse Width = 300 μSec , 1% Duty Cycle
- (4) $T_J = 25^\circ\text{C}$; $f = 1\text{ MHz}$; $V_{\text{sig}} = 50\text{mVp-p}$



1 AMP MINIATURE BRIDGE RECTIFIERS

FEATURES

- Glass Passivated for high reliability/temperature performance
- PRV Ratings from 50 to 1000 Volts
- Surge overload rating to 30 Amps peak
- Reliable low cost molded plastic construction
- Ideal for printed circuit board applications

MECHANICAL DATA

- Case: Molded plastic, U/L Flammability Rating 94V-0
- Terminals: Rectangular pins
- Soldering: Per MIL-STD 202 Method 208 guaranteed
- Polarity: Marked on case
- Mounting Position: Any

MECHANICAL SPECIFICATION

ACTUAL SIZE OF
MDI PACKAGE

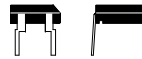

SERIES S1NB05 - S1NB100

SYM	MILLIMETERS		INCHES	
	MIN	MAX	MIN	MAX
A	6.25	6.767	0.246	0.266
B	0.43	0.69	0.017	0.027
BI	0.127	0.381	0.005	0.015
B2	4.75	5.26	0.187	0.207
C	6.55	7.06	0.258	0.278
D	2.27	2.8	0.09	0.11
D1		3.7		0.146
D2	2.9	3.45	0.116	0.136
E	0.8*		0.032*	
M	15° Max		15° Max	

* Chamfer - Typical

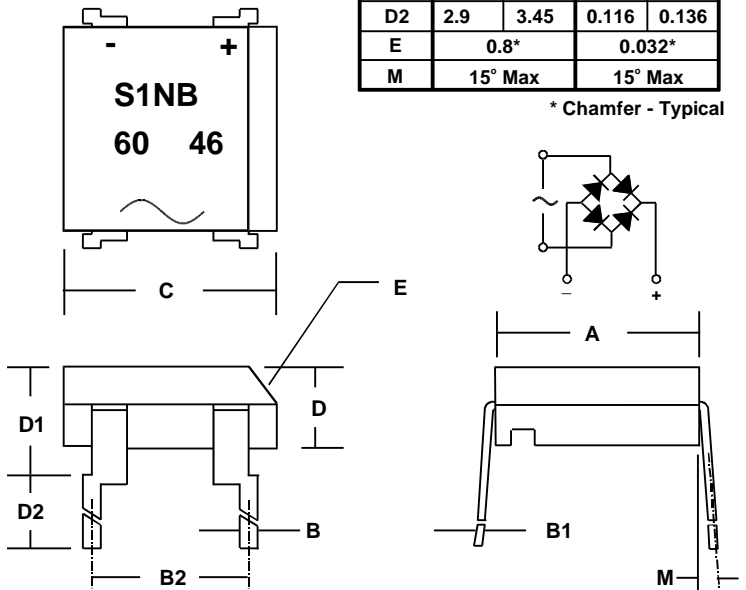

MAXIMUM RATINGS & ELECTRICAL CHARACTERISTICS

Ratings at 25 °C ambient temperature unless otherwise specified.
 Single phase, half wave, 60Hz, resistive or inductive load.
 For capacitive loads, derate current by 20%.

PARAMETER (TEST CONDITIONS)	SYMBOL	RATINGS								UNITS
		S1NB 05	S1NB 10	S1NB 20	S1NB 40	S1NB 60	S1NB 80	S1NB 100		
Series Number										
Maximum DC Blocking Voltage	V _{RM}	50	100	200	400	600	800	1000		VOLTS
Maximum RMS Voltage	V _{RMS}	35	70	140	280	420	560	700		
Maximum Peak Recurrent Reverse Voltage	V _{RRM}	50	100	200	400	600	800	1000		
Average Forward Rectified Current @ T _A = 40° C	I _O	1								AMPS
Peak Forward Surge Current. Single 60Hz Half-Sine Wave Superimposed on Rated Load (JEDEC Method).	I _{FSM}	50								
Maximum Forward Voltage (Per Diode) at 1 Amp DC	V _{FM}	1.05								VOLTS
Maximum Average DC Reverse Current @ T _A = 25° C At Rated DC Blocking Voltage @ T _A = 125° C	I _{RM}	5.0 0.5								μA mA
Typical Thermal Resistance Junction to Ambient (Note 1) Junction to Lead (Note 1)	R _{θJA} R _{θJL}	40 15								°C/W
Operating and Storage Temperature Range	T _J , T _{STG}	-55 to +150								°C

NOTES: (1) Bridge mounted on PC Board with 0.5" sq. (13mm sq.) copper pads

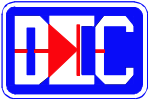

1 AMP MINIATURE BRIDGE RECTIFIERS

RATING & CHARACTERISTIC CURVES FOR SERIES S1NB05 - S1NB100

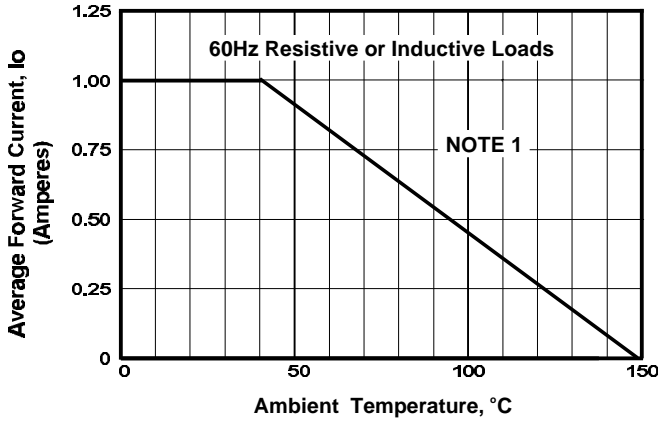

FIGURE 1. FORWARD CURRENT DERATING CURVE

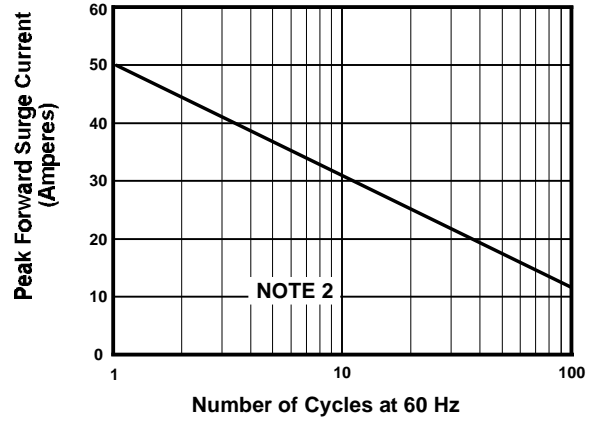

FIGURE 2. MAXIMUM NON-REPETITIVE SURGE CURRENT

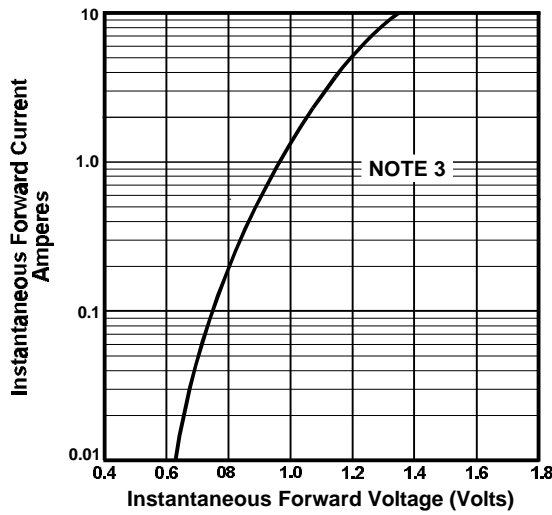

FIGURE 3. TYPICAL FORWARD CHARACTERISTIC PER DIODE

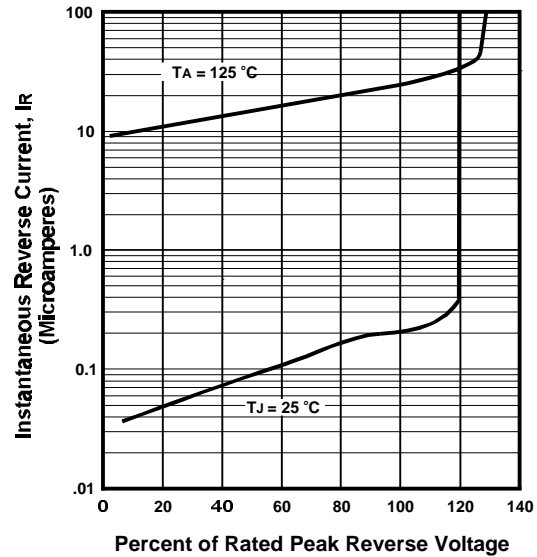

FIGURE 4. TYPICAL REVERSE CHARACTERISTICS

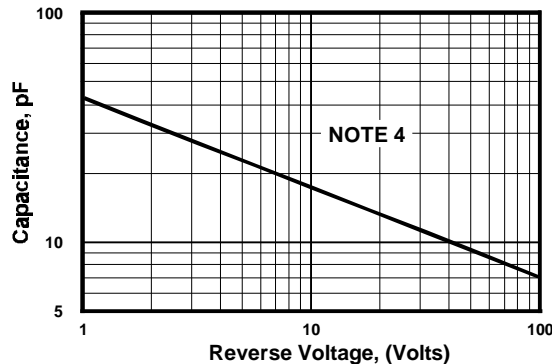
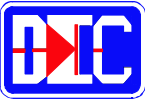

FIGURE 5. TYPICAL JUNCTION CAPACITANCE PER DIODE

NOTES

- (1) Mounted on PC Board With 0.5" Sq. (13 mm Sq.) Solder Pads
- (2) $T_J = 150^\circ\text{C}$
- (3) $T_J = 25^\circ\text{C}$; Pulse Width = 300 μSec , 1% Duty Cycle
- (4) $T_J = 25^\circ\text{C}$; $f = 1\text{ MHz}$; $V_{sig} = 50\text{mVp-p}$



1 AMP SILICON BRIDGE RECTIFIERS

FEATURES

- PRV Ratings from 50 to 1000 Volts
- Surge overload rating to 50 Amps peak
- Reliable low cost molded plastic construction
- Ideal for printed circuit board applications
- **UL RECOGNIZED - FILE #E141956**

MECHANICAL DATA

- Case: Molded plastic, U/L Flammability Rating 94V-0
- Terminals: Round silver plated pins
- Soldering: Per MIL-STD 202 Method 208 guaranteed
- Polarity: Marked on case
- Mounting Position: Any
- Weight: 0.05 Ounces (1.3 Grams)

MECHANICAL SPECIFICATION

ACTUAL SIZE OF
WB PACKAGE

SERIES WB100 - WB110

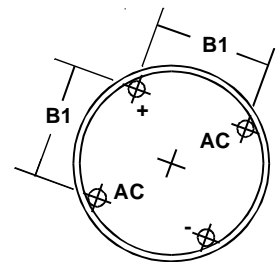
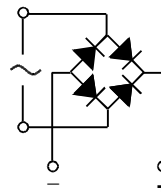
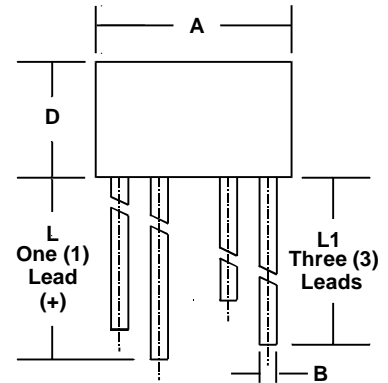

SYM	MILLIMETERS		INCHES	
	MIN	MAX	MIN	MAX
A	8.6	8.89	0.340	0.350
B	0.76	0.81	0.030	0.032
B1	4.6	5.6	0.180	0.220
D	5.1	5.6	0.200	0.220
L	30.5	n/a	1.20	n/a
L1	25.4	n/a	1.0	n/a

MAXIMUM RATINGS & ELECTRICAL CHARACTERISTICS

Ratings at 25 °C ambient temperature unless otherwise specified.
 Single phase, half wave, 60Hz, resistive or inductive load.
 For capacitive loads, derate current by 20%.

PARAMETER (TEST CONDITIONS)	SYMBOL	RATINGS							UNITS
		WB 100	WB 101	WB 102	WB 104	WB 106	WB 108	WB 110	
Series Number									
Maximum DC Blocking Voltage	V _{RM}	50	100	200	400	600	800	1000	VOLTS
Maximum RMS Voltage	V _{RMS}	35	70	140	280	420	560	700	
Maximum Peak Recurrent Reverse Voltage	V _{RRM}	50	100	200	400	600	800	1000	
Average Forward Rectified Current @ T _A = 50° C	I _O	1							AMPS
Peak Forward Surge Current. Single 60Hz Half-Sine Wave Superimposed on Rated Load (JEDEC Method). T _J = 125° C	I _{FSM}	50							
Maximum Forward Voltage (Per Diode) at 1 Amp DC	V _{FM}	1.0							VOLTS
Maximum Average DC Reverse Current At Rated DC Blocking Voltage @ T _A = 25° C	I _{RM}	10 (Typical < 0.1µA)							µA
Typical Thermal Resistance Junction to Ambient (Note 1)	R _{θJA}	40							°C/W
Typical Thermal Resistance Junction to Lead (Note 1)	R _{θJL}	15							
Operating and Storage Temperature Range	T _J , T _{STG}	-40 to +125 (Junction), -40 to +150 (Storage)							°C

NOTES: (1) Bridge mounted on PC Board with 0.2" sq. (5.5mm sq.) copper pads and lead length of 0.375" (9.5mm).

3.0101wb

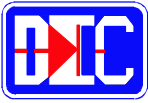

1 AMP SILICON BRIDGE RECTIFIERS

RATING & CHARACTERISTIC CURVES FOR SERIES WB100 - WB110

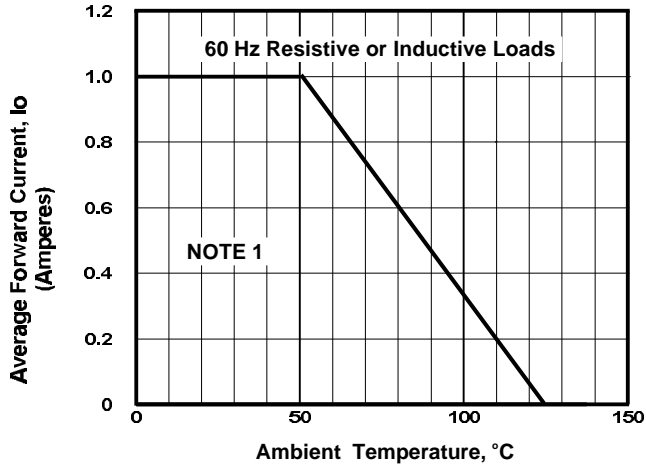

FIGURE 1. FORWARD CURRENT DERATING CURVE

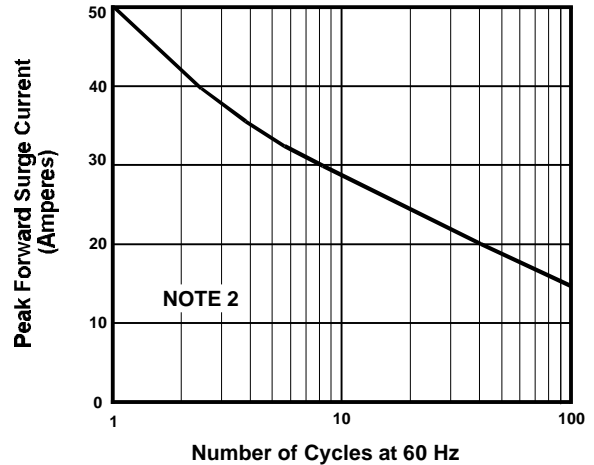

FIGURE 2. MAXIMUM NON-REPETITIVE SURGE CURRENT

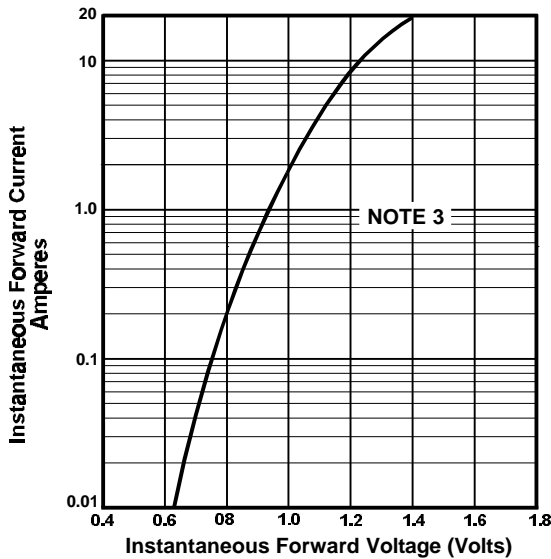

FIGURE 3. TYPICAL FORWARD CHARACTERISTIC PER DIODE

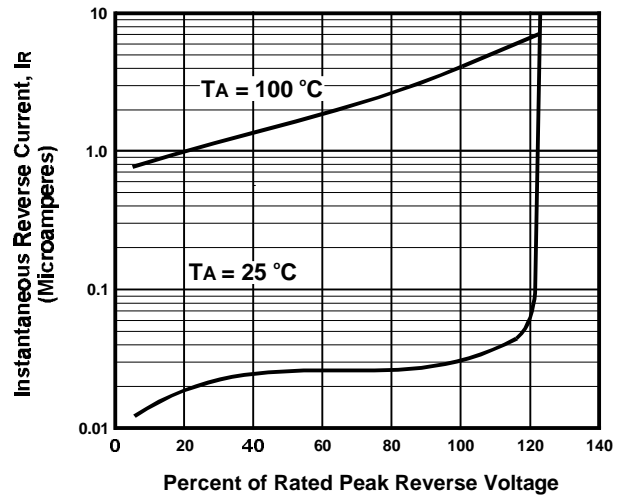

FIGURE 4. TYPICAL REVERSE CHARACTERISTICS

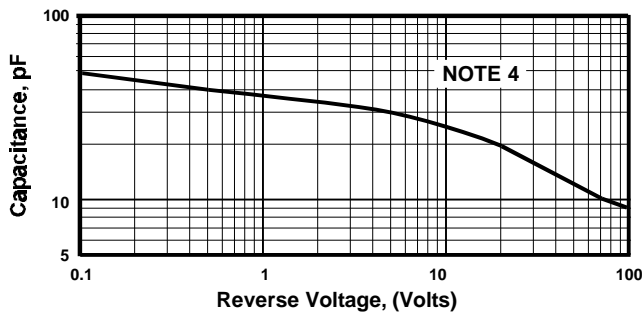
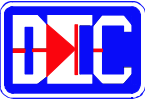

FIGURE 5. TYPICAL JUNCTION CAPACITANCE PER DIODE

NOTES

- (1) Bridge Mounted on PC Board With 0.2" Sq. (5.5mm Sq.) Cooper Pads and Bridge Lead Length of 0.375" (9.5mm)
- (2) $T_J = 125^\circ\text{C}$
- (3) $T_J = 25^\circ\text{C}$; Pulse Width = 300 μSec , 1% Duty Cycle
- (4) $T_J = 25^\circ\text{C}$; $f = 1\text{ MHz}$; $V_{SIG} = 50\text{mVp-P}$



1.5 AMP SILICON BRIDGE RECTIFIERS

FEATURES

- PRV Ratings from 50 to 1000 Volts
- Surge overload rating to 50 Amps peak
- Reliable low cost molded plastic construction
- Ideal for printed circuit board applications
- **UL RECOGNIZED - FILE #E141956**

MECHANICAL DATA

- Case: Molded plastic, U/L Flammability Rating 94V-0
- Terminals: Round silver plated pins
- Soldering: Per MIL-STD 202 Method 208 guaranteed
- Polarity: Marked on case
- Mounting Position: Any
- Weight: 0.05 Ounces (1.3 Grams)

MECHANICAL SPECIFICATION

ACTUAL SIZE OF
WB PACKAGE

SERIES WB150 - WB1510

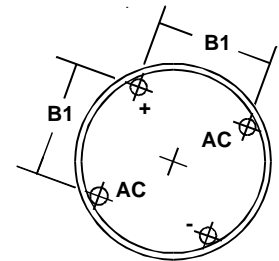
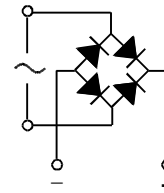
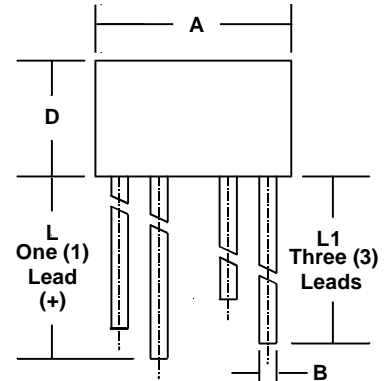

SYM	MILLIMETERS		INCHES	
	MIN	MAX	MIN	MAX
A	8.6	8.89	0.340	0.350
B	0.76	0.81	0.030	0.032
B1	4.6	5.6	0.180	0.220
D	5.1	5.6	0.200	0.220
L	30.5	n/a	1.20	n/a
L1	25.4	n/a	1.0	n/a

MAXIMUM RATINGS & ELECTRICAL CHARACTERISTICS

Ratings at 25 °C ambient temperature unless otherwise specified.
 Single phase, half wave, 60Hz, resistive or inductive load.
 For capacitive loads, derate current by 20%.

PARAMETER (TEST CONDITIONS)	SYMBOL	RATINGS							UNITS
		WB 150	WB 151	WB 152	WB 154	WB 156	WB 158	WB 1510	
Series Number									
Maximum DC Blocking Voltage	V _{RM}	50	100	200	400	600	800	1000	VOLTS
Maximum RMS Voltage	V _{RMS}	35	70	140	280	420	560	700	
Maximum Peak Recurrent Reverse Voltage	V _{RRM}	50	100	200	400	600	800	1000	
Average Forward Rectified Current @ T _A = 25° C	I _O	1.5							AMPS
Peak Forward Surge Current. Single 60Hz Half-Sine Wave Superimposed on Rated Load (JEDEC Method). T _J = 125° C	I _{FSM}	50							
Maximum Forward Voltage (Per Diode) at 1 Amp DC	V _{FM}	1.0							VOLTS
Maximum Average DC Reverse Current At Rated DC Blocking Voltage @ T _A = 25° C	I _{RM}	10 (Typical < 0.1 μA)							μA
Typical Thermal Resistance Junction to Ambient (Note 1)	R _{θJA}	35							°C/W
Typical Thermal Resistance Junction to Lead (Note 1)	R _{θJL}	15							
Operating and Storage Temperature Range	T _J , T _{STG}	-40 to +125 (Junction), -40 to +150 (Storage)							°C

NOTES: (1) Bridge mounted on PC Board with 0.2" sq. (5.5 mm sq.) copper pads and lead length of 0.375" (9.5 mm).

3.011_Swb

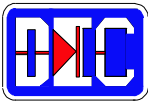

1.5 AMP SILICON BRIDGE RECTIFIERS

RATING & CHARACTERISTIC CURVES FOR SERIES WB150 - WB1510

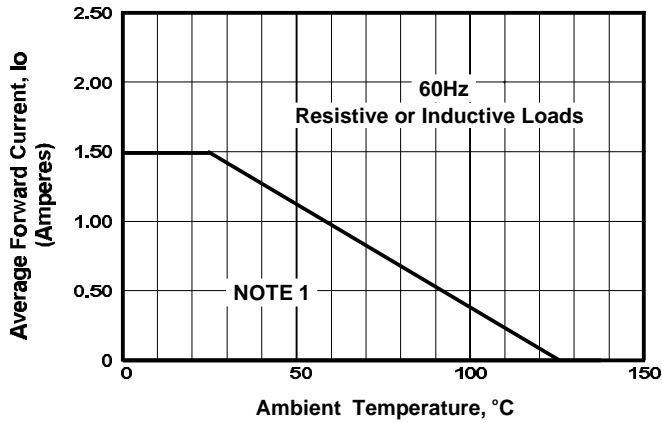

FIGURE 1. FORWARD CURRENT DERATING CURVE

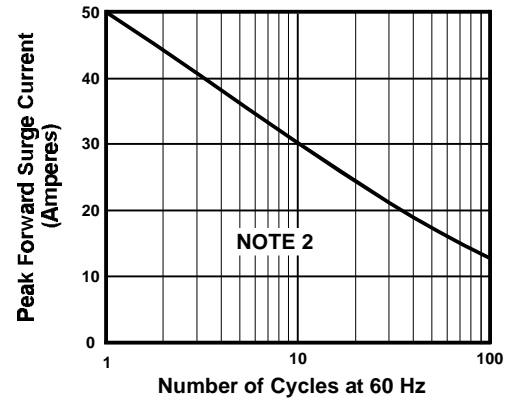

FIGURE 2. MAXIMUM NON-REPETITIVE SURGE CURRENT

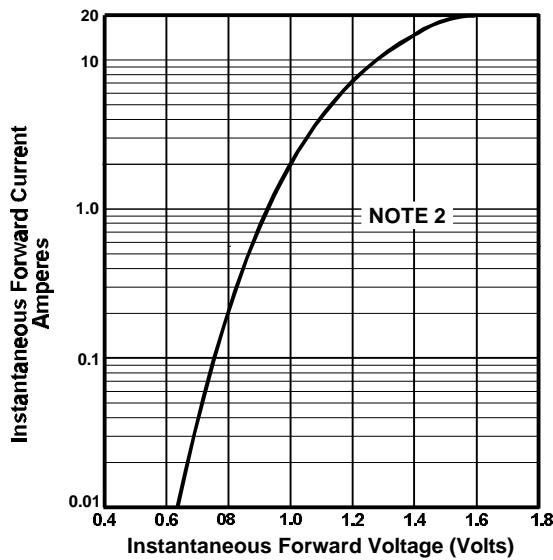

FIGURE 3. TYPICAL FORWARD CHARACTERISTIC PER DIODE

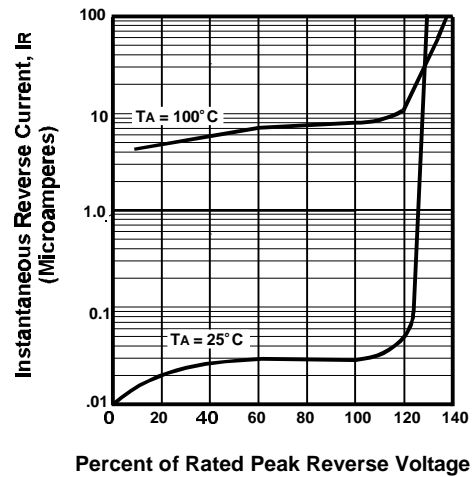

FIGURE 4. TYPICAL REVERSE CHARACTERISTICS

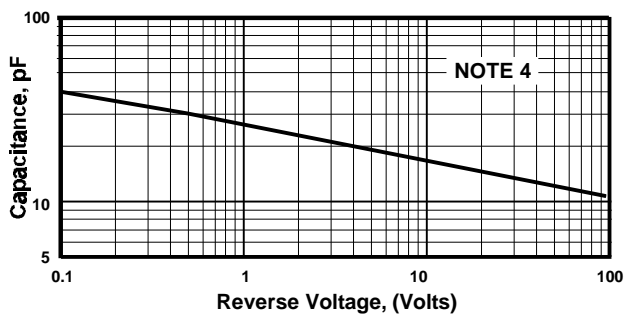
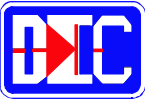

FIGURE 5. TYPICAL JUNCTION CAPACITANCE PER DIODE

NOTES

- (1) Bridge Mounted on PC Board With 0.2" Sq. (5.5mm Sq.) Copper Pads And Bridge Lead Length of 0.375" (9.5mm)
- (2) $T_J = 125^\circ\text{C}$
- (3) $T_J = 25^\circ\text{C}$; Pulse Width = 300 μSec , 1% Duty Cycle
- (4) $T_J = 25^\circ\text{C}$; $f = 1\text{ MHz}$; $V_{\text{sig}} = 50\text{mVp-p}$



2 AMP SILICON BRIDGE RECTIFIERS

FEATURES

- PRV Ratings from 50 to 1000 Volts
- Surge overload rating to 60 Amps peak
- Reliable low cost molded plastic construction
- Ideal for printed circuit board applications
- **UL RECOGNIZED - FILE #E141956**

MECHANICAL DATA

- Case: Molded plastic, U/L Flammability Rating 94V-0
- Terminals: Round silver plated pins
- Soldering: Per MIL-STD 202 Method 208 guaranteed
- Polarity: Marked on case
- Mounting Position: Any
- Weight: 0.05 Ounces (1.3 Grams)

MECHANICAL SPECIFICATION

ACTUAL SIZE OF
WB PACKAGE

SERIES WB200 - WB210

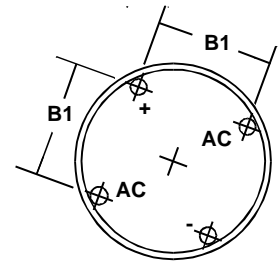
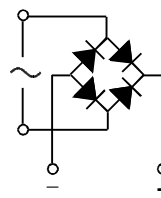
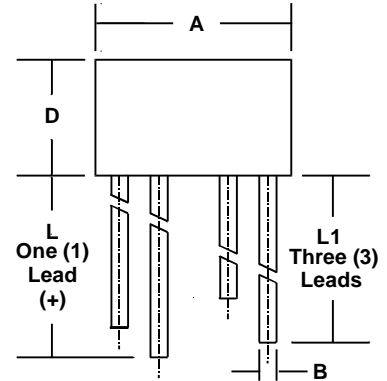

SYM	MILLIMETERS		INCHES	
	MIN	MAX	MIN	MAX
A	8.6	8.89	0.340	0.350
B	0.76	0.81	0.030	0.032
B1	4.6	5.6	0.180	0.220
D	5.1	5.6	0.200	0.220
L	30.5	n/a	1.20	n/a
L1	25.4	n/a	1.0	n/a

MAXIMUM RATINGS & ELECTRICAL CHARACTERISTICS

Ratings at 25 °C ambient temperature unless otherwise specified.
 Single phase, half wave, 60Hz, resistive or inductive load.
 For capacitive loads, derate current by 20%.

PARAMETER (TEST CONDITIONS)	SYMBOL	RATINGS							UNITS
		WB 200	WB 201	WB 202	WB 204	WB 206	WB 208	WB 210	
Series Number									
Maximum DC Blocking Voltage	V _{RM}	50	100	200	400	600	800	1000	VOLTS
Maximum RMS Voltage	V _{RMS}	35	70	140	280	420	560	700	
Maximum Peak Recurrent Reverse Voltage	V _{RRM}	50	100	200	400	600	800	1000	
Average Forward Rectified Current @ T _A = 25° C	I _O	2							AMPS
Peak Forward Surge Current. Single 60Hz Half-Sine Wave Superimposed on Rated Load (JEDEC Method). T _J = 150° C	I _{FSM}	60							
Maximum Forward Voltage (Per Diode) at 2 Amp DC	V _{FM}	1.0							VOLTS
Maximum Average DC Reverse Current @ T _A = 25° C At Rated DC Blocking Voltage @ T _A = 100° C	I _{RM}	10 (Typical < 0.1µA)							µA mA
Typical Thermal Resistance Junction to Ambient (Note 1) Junction to Lead (Note 1)	R _{θJA} R _{θJL}	40 15							°C/W
Operating and Storage Temperature Range	T _J , T _{STG}	-55 to +150							°C

NOTES: (1) Bridge mounted on PC Board with 0.2" sq. (5.5mm sq.) copper pads and lead length of 0.375" (9.5 mm).

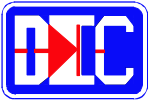

2 AMP SILICON BRIDGE RECTIFIERS

RATING & CHARACTERISTIC CURVES FOR SERIES WB200 - WB210

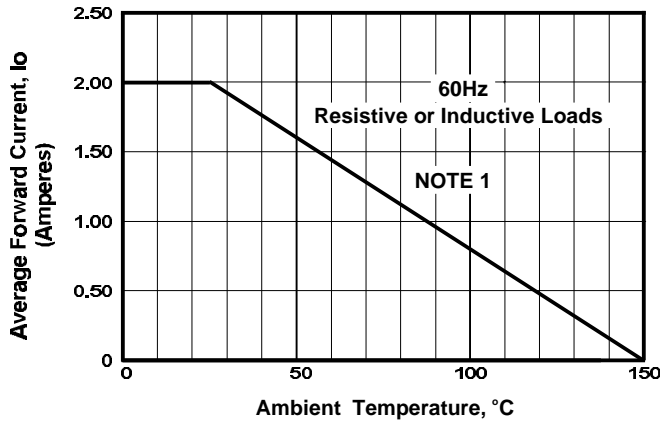

FIGURE 1. FORWARD CURRENT DERATING CURVE

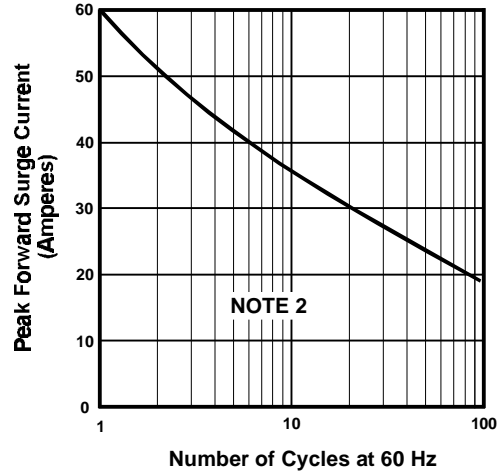

FIGURE 2. MAXIMUM NON-REPETITIVE SURGE CURRENT

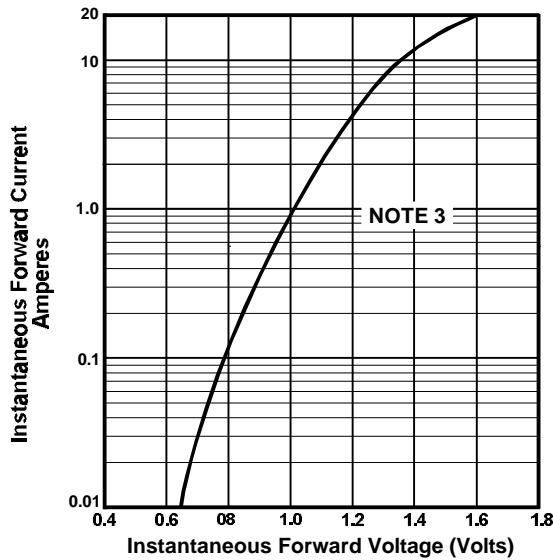

FIGURE 3. TYPICAL FORWARD CHARACTERISTIC PER DIODE

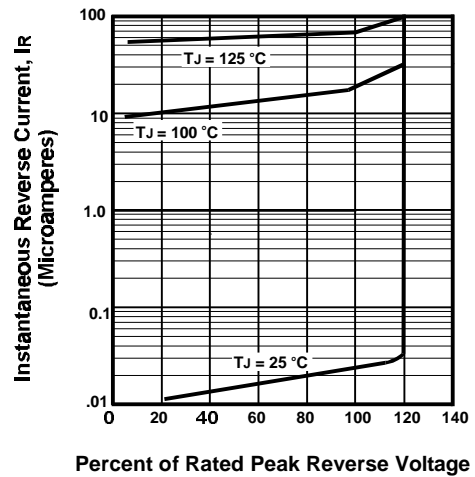

FIGURE 4. TYPICAL REVERSE CHARACTERISTICS

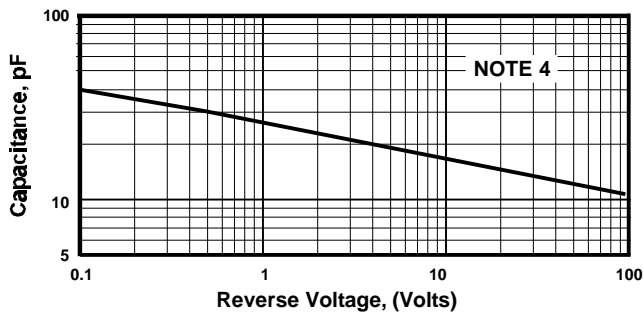

FIGURE 5. TYPICAL JUNCTION CAPACITANCE PER DIODE

NOTES

- (1) Bridge Mounted on PC Board With 0.22" Sq. (5.5mm Sq.) Copper Pads And Bridge Lead Length of 0.375" (9.5mm)
- (2) $T_J = 150^\circ\text{C}$
- (3) $T_J = 25^\circ\text{C}$; Pulse Width = 300 μSec , 1% Duty Cycle
- (4) $T_J = 25^\circ\text{C}$; $f = 1\text{ MHz}$; $V_{\text{sig}} = 50\text{mVp-p}$



2 AMP SILICON BRIDGE RECTIFIERS

FEATURES

- PRV Ratings from 50 to 1000 Volts
- Surge overload rating to 60 Amps peak
- Reliable low cost molded plastic construction
- Ideal for printed circuit board applications

UL RECOGNIZED - FILE #E124962

MECHANICAL DATA

- Case: Molded plastic, U/L Flammability Rating 94V-0
- Terminals: Round silver plated pins
- Soldering: Per MIL-STD 202 Method 208 guaranteed
- Polarity: Marked on case
- Mounting Position: Any
- Weight: 0.1 Ounces (2.8 Grams)

MECHANICAL SPECIFICATION

ACTUAL SIZE OF SB2 PACKAGE

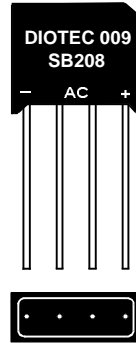

SERIES SB200 - SB210

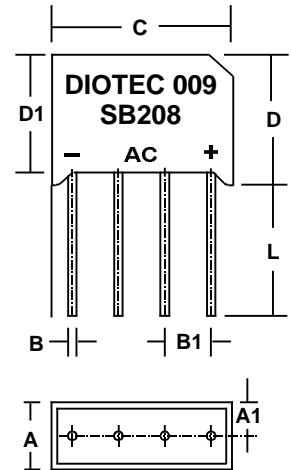

SYM	MILLIMETERS		INCHES	
	MIN	MAX	MIN	MAX
A	5.99	7.01	0.236	0.276
A1	2.99	3.51	0.118	0.138
B	0.71	0.89	0.028	0.035
B1	3.55	4.00	0.140	0.160
C	16.0	18.0	0.63	0.71
D	14.0	15.0	0.55	0.59
D1	13.2	13.7	0.52	0.54
L	12.7	n/a	0.50	n/a

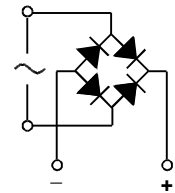

MAXIMUM RATINGS & ELECTRICAL CHARACTERISTICS

Ratings at 25 °C ambient temperature unless otherwise specified.
 Single phase, half wave, 60Hz, resistive or inductive load.
 For capacitive loads, derate current by 20%.

PARAMETER (TEST CONDITIONS)	SYMBOL	RATINGS							UNITS
		SB 200	SB 201	SB 202	SB 204	SB 206	SB 208	SB 210	
Series Number									
Maximum DC Blocking Voltage	V _{RM}	50	100	200	400	600	800	1000	VOLTS
Maximum RMS Voltage	V _{RMS}	35	70	140	280	420	560	700	
Maximum Peak Recurrent Reverse Voltage	V _{RRM}	50	100	200	400	600	800	1000	
Average Forward Rectified Current @ T _A = 55° C	I _o	2							AMPS
Peak Forward Surge Current. Single 60Hz Half-Sine Wave Superimposed on Rated Load (JEDEC Method). T _J = 150° C	I _{FSM}	60							
Maximum Forward Voltage (Per Diode) at 1 Amp DC	V _{FM}	1.05							VOLTS
Maximum Average DC Reverse Current @ T _A = 25° C	I _{RM}	10							μA
At Rated DC Blocking Voltage @ T _A = 125° C		500							
Typical Thermal Resistance. Junction to Ambient (Note 1)	R _{θJA}	30							°C/W
Junction to Lead (Note 1)	R _{θJL}	11							
Operating and Storage Temperature Range	T _J , T _{STG}	-55 to +150							°C

NOTES: (1) Bridge mounted on PC Board with 0.47" sq.(12mm sq.) copper pads.

3.01 0220

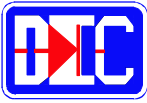

2 AMP SILICON BRIDGE RECTIFIERS

RATING & CHARACTERISTIC CURVES FOR SB200 - SB210 SERIES

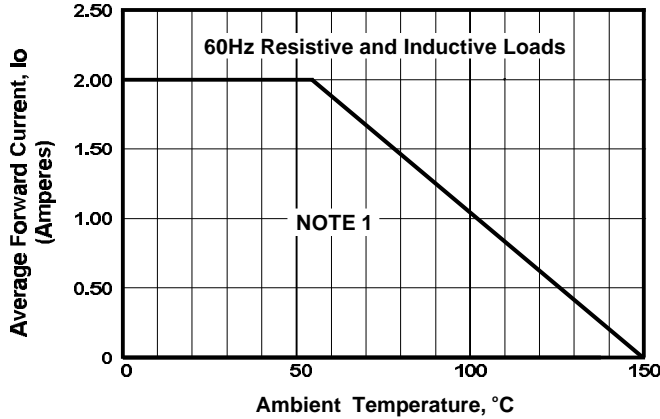

FIGURE 1. FORWARD CURRENT DERATING CURVE

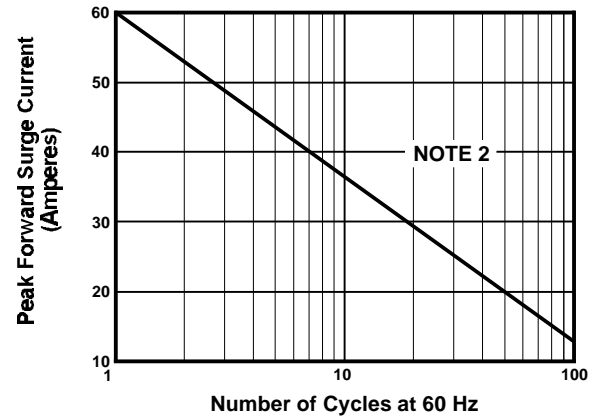

FIGURE 2. MAXIMUM NON-REPETITIVE SURGE CURRENT

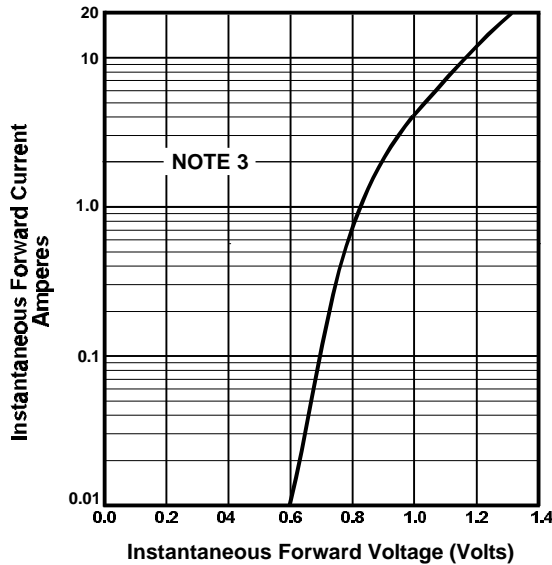

FIGURE 3. TYPICAL FORWARD CHARACTERISTIC PER DIODE

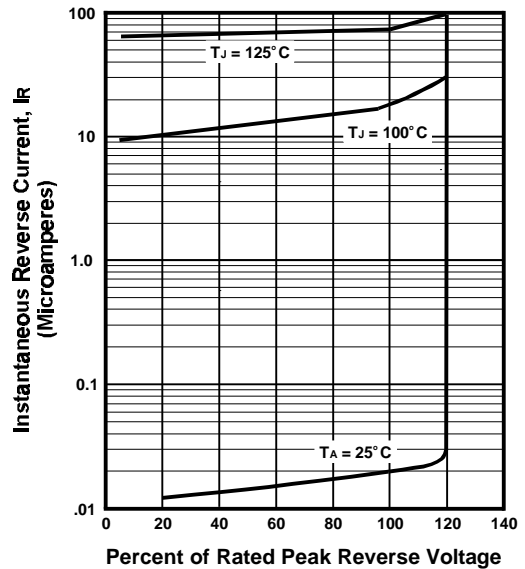

FIGURE 4. TYPICAL REVERSE CHARACTERISTICS

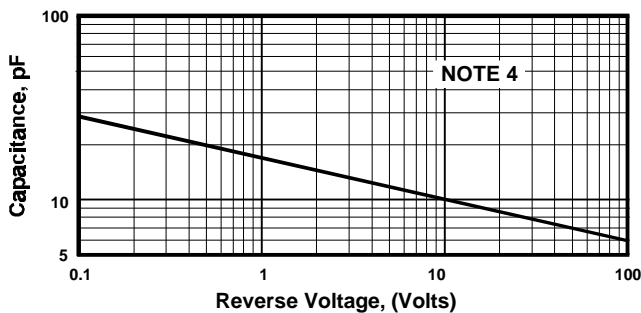
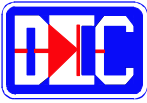

FIGURE 5. TYPICAL JUNCTION CAPACITANCE PER DIODE

NOTES

- (1) Bridge Mounted on PC Board With 0.47" Sq. (12mm Sq.) Copper Pads
- (2) $T_J = 150^\circ\text{C}$
- (3) $T_J = 25^\circ\text{C}$; Pulse Width = 300 μSec , 1% Duty Cycle
- (4) $T_J = 25^\circ\text{C}$; $f = 1\text{ MHz}$; $V_{\text{SIG}} = 50\text{mV}_{\text{P-P}}$



3 AMP SILICON BRIDGE RECTIFIERS

FEATURES

- PRV Ratings from 50 to 1000 Volts
- High surge overload rating of 60 Amps peak
- Reliable low cost molded plastic construction
- Ideal for printed circuit board applications
- **UL RECOGNIZED - FILE #E124962**

MECHANICAL DATA

- Case: Molded plastic, U/L Flammability Rating 94V-0
- Terminals: Round silver plated copper pins
- Soldering: Per MIL-STD 202 Method 208 guaranteed (NOTE 1)
- Polarity: Marked on top of case; positive lead at beveled corner
- Mounting Position: Any. Thru hole provided for #6 screw (NOTE 2)
- Weight: 0.13 Ounces (3.6 Grams)

MECHANICAL SPECIFICATION

ACTUAL SIZE

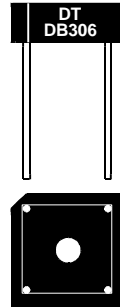

SERIES DB300-DB310 and ADB304-ADB308

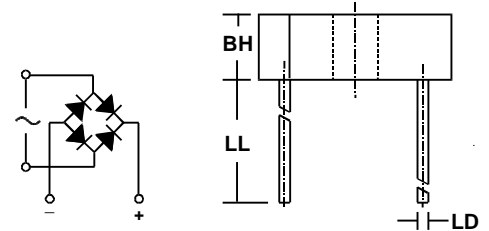

SYM	MILLIMETERS		INCHES	
	MIN	MAX	MIN	MAX
BL	14.7	15.7	0.58	0.62
BH	4.8	5.3	0.19	0.21
D1	10.3	11.3	0.405	0.445
LL	19.0	n/a	0.75	n/a
LD	0.7	0.9	0.028	0.035

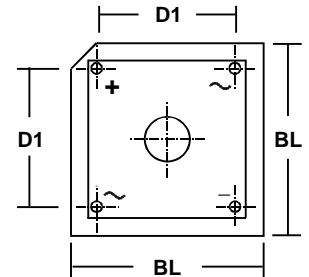

MAXIMUM RATINGS & ELECTRICAL CHARACTERISTICS

Ratings at 25 °C ambient temperature unless otherwise specified. Single phase, 60Hz, resistive or inductive load. For capacitive loads, derate current by 20%.

PARAMETER (TEST CONDITIONS)	SYMBOL	RATINGS										UNITS
		CONTROLLED AVALANCHE			NON-CONTROLLED AVALANCHE							
		ADB 304	ADB 306	ADB 308	DB 300	DB 301	DB 302	DB 304	DB 306	DB 308	DB 310	
Series Number												
Maximum DC Blocking Voltage	V _{RM}											VOLTS
Working Peak Reverse Voltage	V _{RWM}	400	600	800	50	100	200	400	600	800	1000	
Maximum Peak Recurrent Reverse Voltage	V _{RRM}											
RMS Reverse Voltage	V _R (RMS)	280	420	560	35	70	140	280	420	560	700	
Power Dissipation in V _(BR) Region for 100 μS Square Wave	P _{RM}	300			n/a							WATTS
Continuous Power Dissipation in V _(BR) Region @ T _{HS} =80 °C (Heat Sink Temp)	P _R	1			n/a							
Thermal Energy (Rating for Fusing) t < 8.3mSec	I ² t	15										AMPS ² SEC
Peak Forward Surge Current. Single 60Hz Half-Sine Wave Superimposed on Rated Load (JEDEC Method). T _c = 60 °C	I _{FSM}	60										AMPS
Average Forward Rectified Current @ T _c = 60 °C (Note 2) @ T _A = 25 °C (Note 3)	I _o	3 2										
Junction Operating and Storage Temperature Range	T _J , T _{STG}	-55 to +150										°C
Minimum Avalanche Voltage	V _(BR) Min	450	650	850	n/a							VOLTS
Maximum Avalanche Voltage	V _(BR) Max	900	1100	1300	n/a							
Maximum Forward Voltage (Per Diode) at 1.5 Amps DC	V _{FM}	0.95 (Typical < 0.9)										
Typical Junction Capacitance (Note 4)	C _J	21										pF
Maximum Reverse Current at Rated V _{RM} @ T _A = 25 °C @ T _A = 125 °C	I _{RM}	5 (Typical < 0.1 μA) 500										μA
Minimum Insulation Breakdown Voltage (Circuit to Case)	V _{ISO}	2500										VOLTS
Typical Thermal Resistance Junction to Ambient (Note 2) Junction to Case (Note 2)	R _{θJA}	12.0										°C/W
	R _{θJC}	8.0										

NOTES: (1) Bolt bridge on heat sink with #6 screw, using silicon thermal compound between bridge and mounting surface for maximum heat transfer.
 (2) Bridge mounted on 4.0" sq. x 0.11" thick (10.5cm sq. x 0.3cm) aluminum plate
 (3) Bridge mounted on PC Board with 0.5" sq. (12mm sq.) copper pads and bridge lead length of 0.375" (9.5mm)
 (4) Measured at 1.0 MHz and applied reverse voltage of 4.0 Volts

3.01 0306

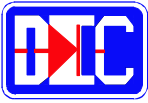

3 AMP SILICON BRIDGE RECTIFIERS

RATING & CHARACTERISTIC CURVES FOR SERIES DB300 - DB310 and SERIES ADB304 - ADB308

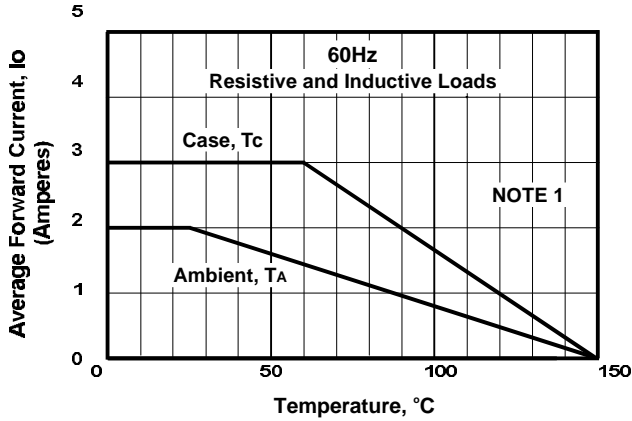

FIGURE 1. FORWARD CURRENT DERATING CURVE

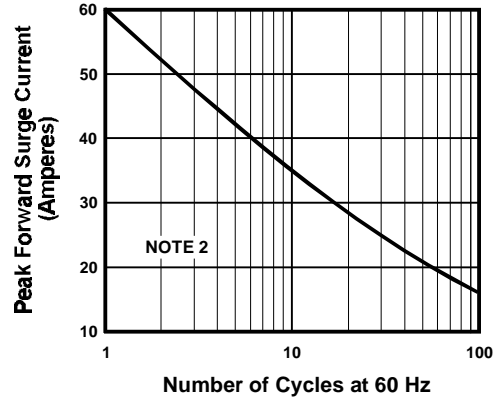

FIGURE 2. MAXIMUM NON-REPETITIVE SURGE CURRENT

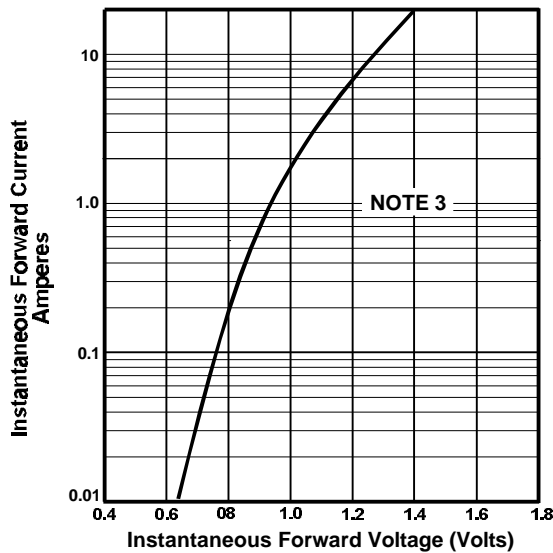

FIGURE 3. TYPICAL FORWARD CHARACTERISTIC PER DIODE

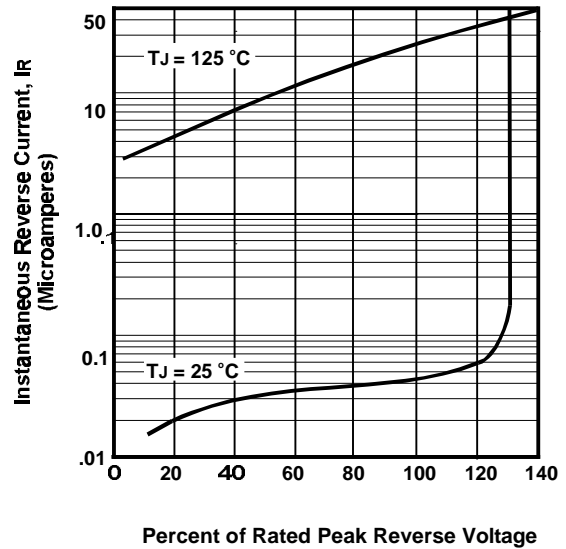

FIGURE 4. TYPICAL REVERSE CHARACTERISTICS

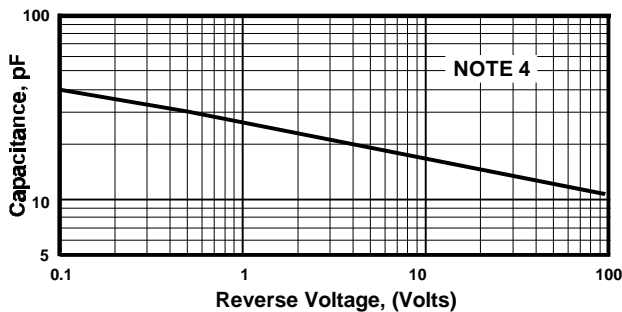
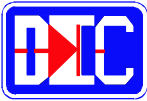

FIGURE 5. TYPICAL JUNCTION CAPACITANCE PER DIODE

NOTES

- (1) Case Temperature, T_c , With Bridge Mounted on 4" Sq. x 0.11" Thick (10.5cm Sq. x 0.3cm) Aluminum Plate
 Ambient Temperature, T_a , With Bridge Mounted on PC Board With 0.5" Sq. (12mm Sq.) Pads and Lead Length of 0.375" (9.5mm)
- (2) $T_c = 60^\circ\text{C}$
- (3) $T_J = 25^\circ\text{C}$; Pulse Width = 300 μSec ; 1% Duty Cycle
- (4) $T_J = 25^\circ\text{C}$; $f = 1\text{ MHz}$; $V_{sig} = 50\text{mVp-p}$



4 AMP SILICON BRIDGE RECTIFIERS

FEATURES

- VOID FREE VACUUM DIE SOLDERING FOR MAXIMUM MECHANICAL STRENGTH AND HEAT DISSIPATION (Solder Voids: Typical < 2%, Max. < 10% of Die Area)
- BUILT-IN STRESS RELIEF MECHANISM FOR SUPERIOR RELIABILITY AND PERFORMANCE
- SURGE OVERLOAD RATING TO 200 AMPS PEAK
- **UL RECOGNIZED - FILE #E124962**

MECHANICAL DATA

- Case: Molded plastic, U/L Flammability Rating 94V-0
- Terminals: Round silver plated copper pins
- Soldering: Per MIL-STD 202 Method 208 guaranteed (NOTE 1)
- Polarity: Marked on case
- Mounting Position: Any.
- Weight: 0.2 Ounces (5.6 Grams)

MECHANICAL SPECIFICATION

ACTUAL SIZE OF SB4 PACKAGE

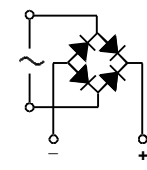
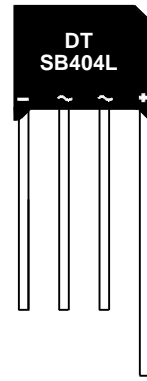

SERIES: **SB400L - SB410L**
ASB404L - ASB408L

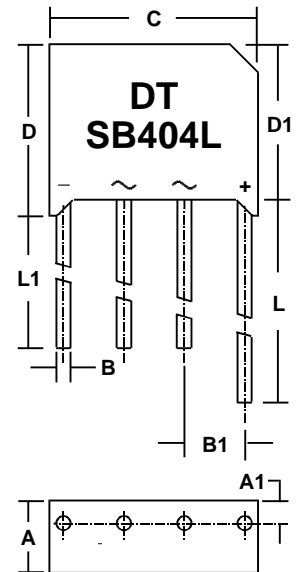

SYM	MILLIMETERS		INCHES	
	MIN	MAX	MIN	MAX
A	6.4	6.65	0.252	0.262
A1	2.06	2.18	0.061	0.065
B	1.22	1.32	0.048	0.052
B1	4.57	5.59	0.180	0.220
C	19.1	19.3	0.750	0.760
D	15.62	15.88	0.615	0.625
D1	14.38*	n/a	0.566*	n/a
L	27.94	n/a	1.2	n/a
L1	25.4	n/a	1.0	n/a

* This measurement is "Typical"

MAXIMUM RATINGS & ELECTRICAL CHARACTERISTICS

Ratings at 25 °C ambient temperature unless otherwise specified.
 Single phase, half wave, 60Hz, resistive or inductive load.
 For capacitive loads, derate current by 20%.

PARAMETER (TEST CONDITIONS)	SYMBOL	RATINGS										UNITS
		CONTROLLED AVALANCHE				NON-CONTROLLED AVALANCHE						
		ASB 404L	ASB 406L	ASB 408L	SB 400L	SB 401L	SB 402L	SB 404L	SB 406L	SB 408L	SB 410L	
Series Number												
Maximum DC Blocking Voltage	V _{RM}											VOLTS
Working Peak Reverse Voltage	V _{RWM}	400	600	800	50	100	200	400	600	800	1000	
Maximum Peak Recurrent Reverse Voltage	V _{RRM}											
RMS Reverse Voltage	V _R (RMS)	280	420	560	35	70	140	280	420	560	700	
Thermal Energy (Rating for Fusing)	I ² t	93										AMPS ² SEC
Peak Forward Surge Current. Single 60Hz Half-Sine Wave Superimposed on Rated Load (JEDEC Method) T _J = 150 °C	I _{FSM}	200										AMPS
Average Forward Rectified Current @ T _A = 50 °C	I _o	4										
Junction Operating and Storage Temperature Range	T _J , T _{STG}	-55 to +150										°C
Minimum Avalanche Voltage	V _{(BR) MIN}	450	650	850	n/a						VOLTS	
Maximum Avalanche Voltage	V _{(BR) MAX}	900	1100	1300	n/a							
Maximum Forward Voltage (Per Diode) at 4 Amps DC	V _{FM}	0.95 (Typical < 0.90)										
Maximum Reverse Current at Rated V _{RM} @ T _A = 25 °C @ T _A = 125 °C	I _{RM}	5 1										µA mA
Minimum Insulation Breakdown Voltage (Circuit to Case)	V _{ISO}	2500										VOLTS
Typical Thermal Resistance Junction to Ambient (Note 1) Junction to Lead (Note 2)	R _{θJA} R _{θJL}	19.0 2.4										°C/W

NOTES: (1) Bridge mounted on 3.0" sq. x 0.11" thick (7.5cm sq. x 0.3cm) aluminum plate.
 (2) Bridge mounted on PC Board with 0.5" sq. (12mm sq.) copper pads and a lead length of 0.375" (9.5mm).

3.01 0450

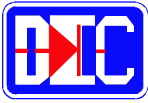

4 AMP SILICON BRIDGE RECTIFIERS

RATING & CHARACTERISTIC CURVES FOR SERIES SB400L - SB410L and SERIES ASB404L - ASB408L

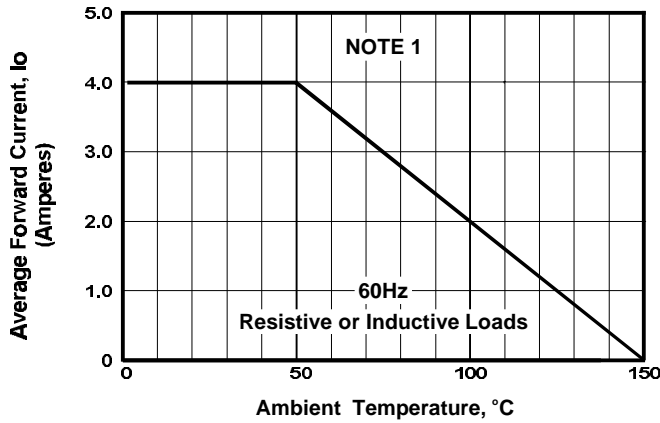

FIGURE 1. FORWARD CURRENT DERATING CURVE

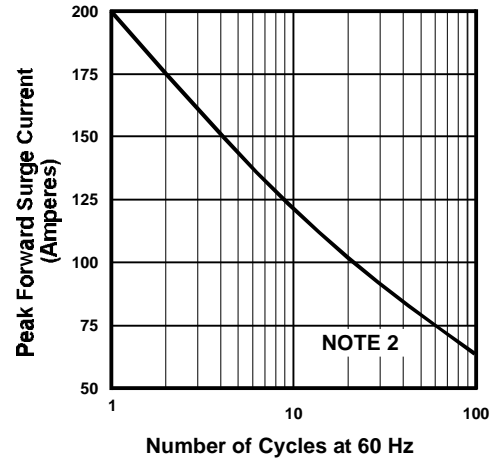

FIGURE 2. MAXIMUM NON-REPETITIVE SURGE CURRENT

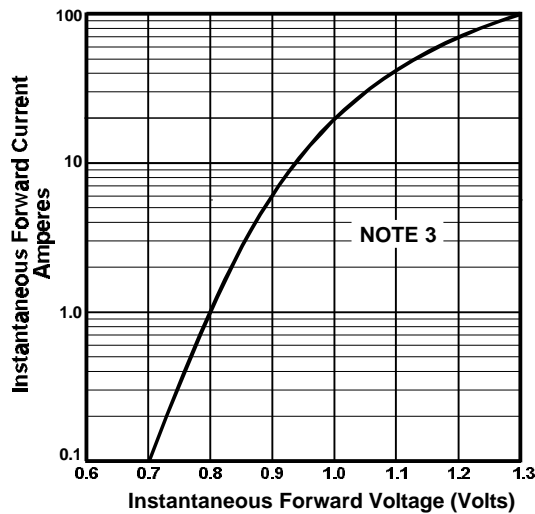

FIGURE 3. TYPICAL FORWARD CHARACTERISTIC PER DIODE

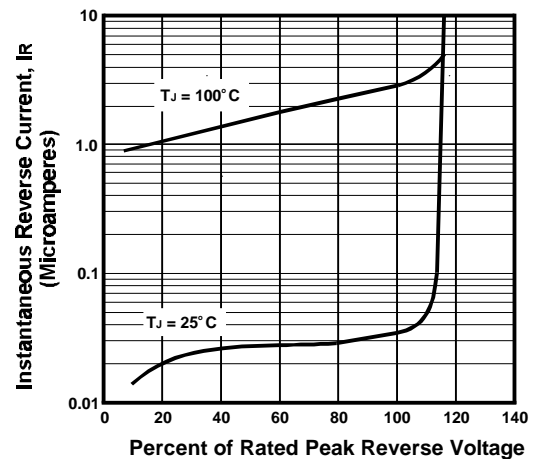

FIGURE 4. TYPICAL REVERSE CHARACTERISTICS

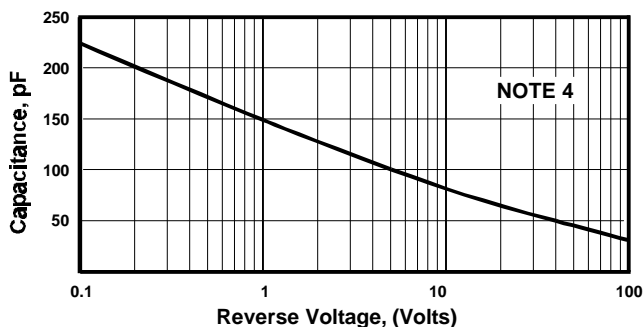
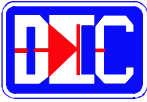

FIGURE 5. TYPICAL JUNCTION CAPACITANCE PER DIODE

NOTES

- (1) Bridge Mounted on 3.0" Sq. x 0.11" Thick (7.5cm Sq. x 0.15cm) Aluminum Plate
- (2) $T_J = 150^\circ\text{C}$
- (3) $T_J = 25^\circ\text{C}$; Pulse Width = 300 μSec ; 1%Duty Cycle
- (4) $T_J = 25^\circ\text{C}$; $f = 1\text{ MHz}$; $V_{sig} = 50\text{mVp-p}$



4 AMP SILICON BRIDGE RECTIFIERS

FEATURES

- VOID FREE VACUUM DIE SOLDERING FOR MAXIMUM MECHANICAL STRENGTH AND HEAT DISSIPATION (Solder Voids: Typical < 2%, Max. < 10% of Die Area)
- BUILT-IN STRESS RELIEF MECHANISM FOR SUPERIOR RELIABILITY AND PERFORMANCE
- SURGE OVERLOAD RATING TO 200 AMPS PEAK
- IDEAL FOR PRINTED CIRCUIT BOARD APPLICATIONS
- **UL RECOGNIZED - FILE #E141956**

MECHANICAL DATA

- Case: Molded plastic, U/L Flammability Rating 94V-0
- Terminals: Round silver plated pins
- Soldering: Per MIL-STD 202 Method 208 guaranteed
- Polarity: Marked on case
- Mounting Position: Any
- Weight: 0.2 Ounces (5.6 Grams)

MECHANICAL SPECIFICATION

ACTUAL SIZE OF
KBL PACKAGE

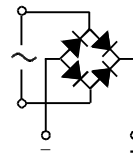
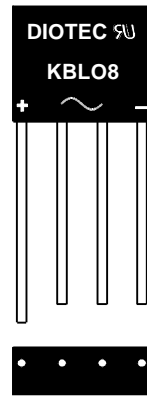

SERIES KBL00 - KBL10

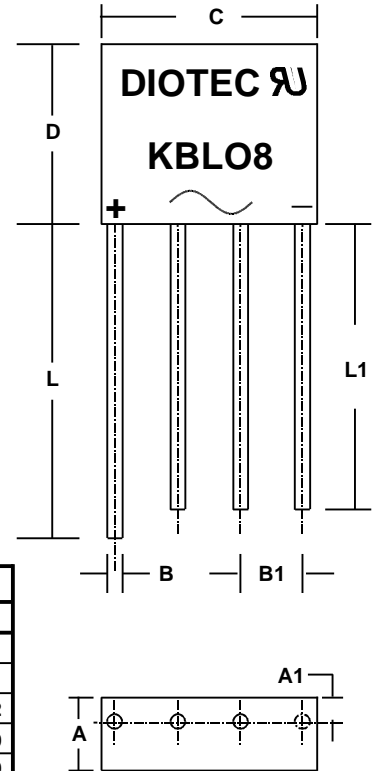

SYM	MILLIMETERS		INCHES	
	MIN	MAX	MIN	MAX
A	6.22	6.48	0.245	0.255
A1	2.05	2.18	0.081	0.085
B	1.22	1.32	0.048	0.052
B1	4.57	5.59	0.180	0.220
C	18.90	19.10	0.620	0.630
D	12.1	12.7	0.470	0.500
L	27.94	n/a	1.10	n/a
L1	25.4	n/a	1.00	n/a

MAXIMUM RATINGS & ELECTRICAL CHARACTERISTICS

Ratings at 25 °C ambient temperature unless otherwise specified.
 Single phase, half wave, 60Hz, resistive or inductive load.
 For capacitive loads, derate current by 20%.

PARAMETER (TEST CONDITIONS)	SYMBOL	RATINGS								UNITS
		KBL 00	KBL 01	KBL 02	KBL 04	KBL 06	KBL 08	KBL 10		
Series Number										
Maximum DC Blocking Voltage	V _{RM}	50	100	200	400	600	800	1000		VOLTS
Maximum RMS Voltage	V _{RMS}	35	70	140	280	420	560	700		
Maximum Peak Recurrent Reverse Voltage	V _{RRM}	50	100	200	400	600	800	1000		
Average Forward Rectified Current @ T _A = 65° C	I _O	4								AMPS
Peak Forward Surge Current. Single 60Hz Half-Sine Wave Superimposed on Rated Load (JEDEC Method). T _J = 150° C	I _{FSM}	200								
Maximum Forward Voltage (Per Diode) at 4 Amps DC	V _{FM}	0.95 (Typical < 0.90)								VOLTS
Maximum Average DC Reverse Current @ T _A = 25° C	I _{RM}	5								μA
At Rated DC Blocking Voltage @ T _A = 100° C		1								
Typical Thermal Resistance	R _{θJA}	19.0								°C/W
	R _{θJL}	2.4								
Operating and Storage Temperature Range	T _J , T _{STG}	-55 to +150								°C

NOTES: (1) Bridge mounted on 3.0" sq. x 0.11" thick (7.5cm sq. x 0.3cm) aluminum plate.
 (2) Bridge mounted on PC Board with 0.5" sq. (12mm sq.) copper pads and a lead length of 0.375" (9.5mm).

3.0104kbl

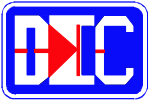

4 AMP SILICON BRIDGE RECTIFIERS

RATING & CHARACTERISTIC CURVES FOR SERIES KBL00 - KBL10

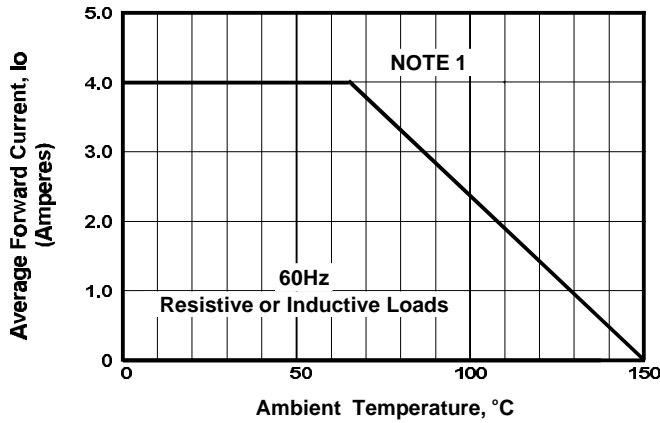

FIGURE 1. FORWARD CURRENT DERATING CURVE

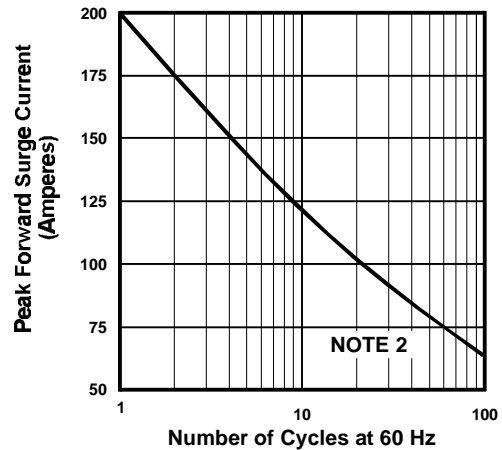

FIGURE 2. MAXIMUM NON-REPETITIVE SURGE CURRENT

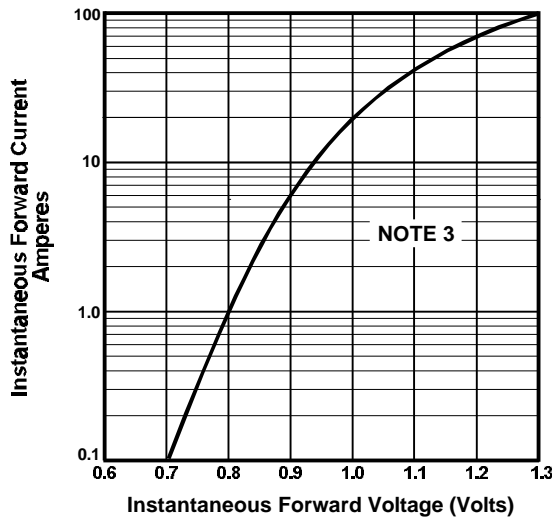

FIGURE 3. TYPICAL FORWARD CHARACTERISTIC PER DIODE

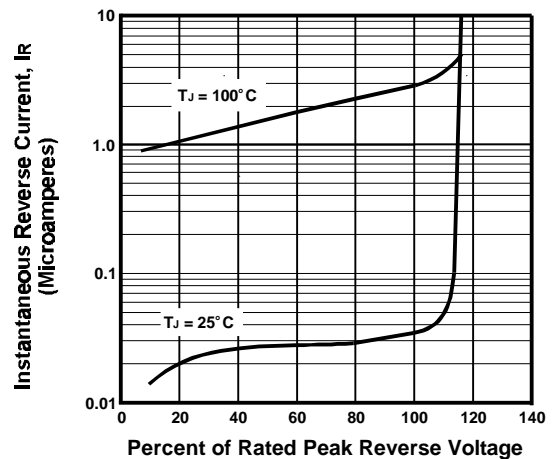

FIGURE 4. TYPICAL REVERSE CHARACTERISTICS

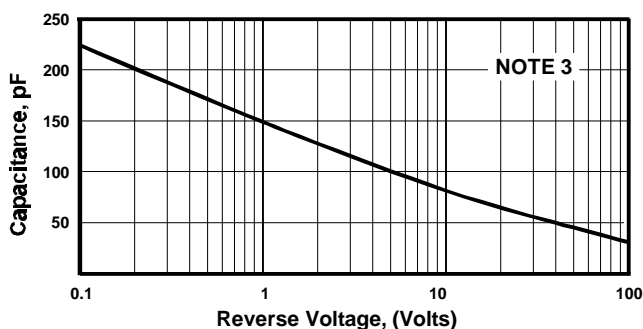
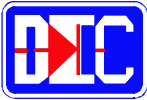

FIGURE 5. TYPICAL JUNCTION CAPACITANCE PER DIODE

NOTES

- (1) Bridge Mounted on 3.0" Sq. x 0.11" Thick (7.5cm Sq. x 0.15cm) Aluminum Plate
- (2) $T_J = 150^\circ\text{C}$
- (3) $T_J = 25^\circ\text{C}$; Pulse Width = 300 μSec ; 1%Duty Cycle
- (4) $T_J = 25^\circ\text{C}$; $f = 1\text{ MHz}$; $V_{\text{sig}} = 50\text{mVp-p}$



4 AMP SILICON BRIDGE RECTIFIERS

FEATURES

- VOID FREE VACUUM DIE SOLDERING FOR MAXIMUM MECHANICAL STRENGTH AND HEAT DISSIPATION (Solder Voids: Typical < 2%, Max. < 10% of Die Area)
- BUILT-IN STRESS RELIEF MECHANISM FOR SUPERIOR RELIABILITY AND PERFORMANCE
- SURGE OVERLOAD RATING TO 200 AMPS PEAK
- IDEAL FOR PRINTED CIRCUIT BOARD APPLICATIONS
- **UL RECOGNIZED - FILE #E124962**

MECHANICAL SPECIFICATION

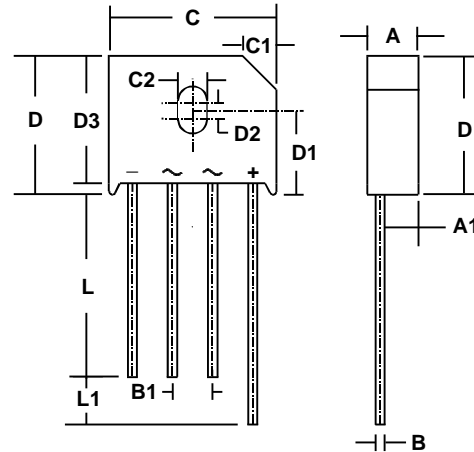

MECHANICAL DATA

- Case: Molded plastic, U/L Flammability Rating 94V-0
- Terminals: Round silver plated pins
- Soldering: Per MIL-STD 202 Method 208 guaranteed
- Polarity: Marked on case
- Mounting Position: Any. Max. mounting torque = 5 in lb
- Weight: 0.3 Ounces (8 Grams)

SYM	MILLIMETERS		INCHES	
	MIN	MAX	MIN	MAX
A	6.6	7.1	0.260	0.280
A1	4.7	5.2	0.185	0.205
B	1.22	1.32	0.048	0.052
B1	4.57	5.59	0.180	0.220
C	22.70	23.24	0.895	0.915
C1	4.2	4.7	0.165	0.185
C2	3.6	4.1	0.140	0.160
D	n/a	19.3	n/a	0.760
D1	10.3	11.3	0.405	0.455
D2	1.7	2.2	0.065	0.085
D3	16.5	17.8	0.660	0.700
L	25.4	n/a	1.0	n/a
L1	4.57	6.8	0.180	0.260

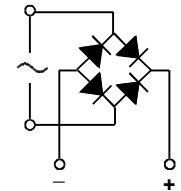

SERIES SBU4A - SBU4M

MAXIMUM RATINGS & ELECTRICAL CHARACTERISTICS

Ratings at 25 °C ambient temperature unless otherwise specified. Single phase, 60Hz, resistive or inductive load. For capacitive loads, derate current by 20%.

PARAMETER (TEST CONDITIONS)	SYMBOL	RATINGS								UNITS
		SBU 4A	SBU 4B	SBU 4D	SBU 4G	SBU 4J	SBU 4K	SBU 4M		
Series Number										
Maximum DC Blocking Voltage	V _{RM}	50	100	200	400	600	800	1000		VOLTS
Maximum RMS Voltage	V _{RMS}	35	70	140	280	420	560	700		
Maximum Peak Recurrent Reverse Voltage	V _{RRM}	50	100	200	400	600	800	1000		
Average Forward Rectified Current T _c = 100° C (Note 1) T _A = 30° C (Note 2)	I _O	4 4								AMPS
Peak Forward Surge Current. Single 60Hz Half-Sine Wave Superimposed on Rated Load (JEDEC Method). T _J = 150° C	I _{FSM}	200								
Maximum Forward Voltage (Per Diode) at 4 Amps DC	V _{FM}	0.95 (Typical < 0.90)								VOLTS
Maximum Average DC Reverse Current At Rated DC Blocking Voltage @ T _A = 25° C @ T _A = 100° C	I _{RM}	5 (Typical < 0.1μA) 100								μA
Typical Thermal Resistance Junction to Ambient (Note 2) Junction to Lead (Note 1)	R _{θJA} R _{θJL}	19.0 2.4								°C/W
Operating and Storage Temperature Range	T _J , T _{STG}	-55 to +150								°C

NOTES: (1) Bridge mounted on 2.0" x 1.6" x 0.3" thick (5cm x 4cm x 0.8cm) aluminum plate
 (2) Bridge mounted on PC Board with 0.5" sq. (12mm sq.) copper pads and bridge lead length of 0.375" (9.5mm)
 (3) Bolt bridge on heat sink with #6 screw, using silicon thermal compound between bridge and mounting surface for maximum heat transfer.

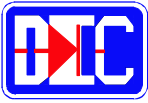

4 AMP SILICON BRIDGE RECTIFIERS

RATING & CHARACTERISTIC CURVES FOR SERIES SBU4A - SBU4M

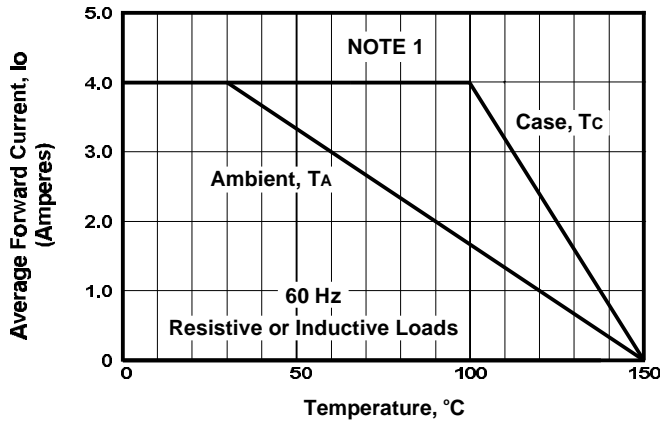

FIGURE 1. FORWARD CURRENT DERATING CURVE

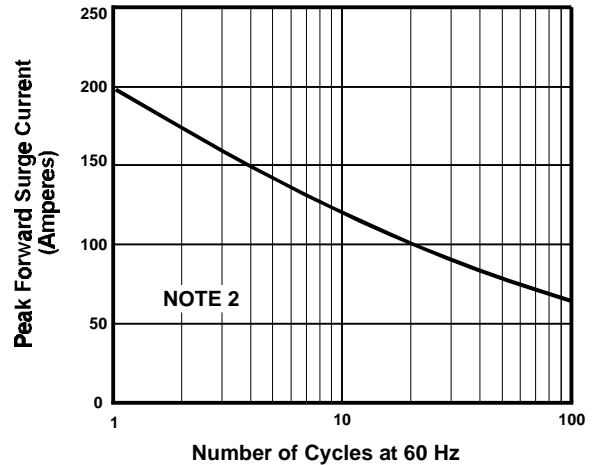

FIGURE 2. MAXIMUM NON-REPETITIVE SURGE CURRENT

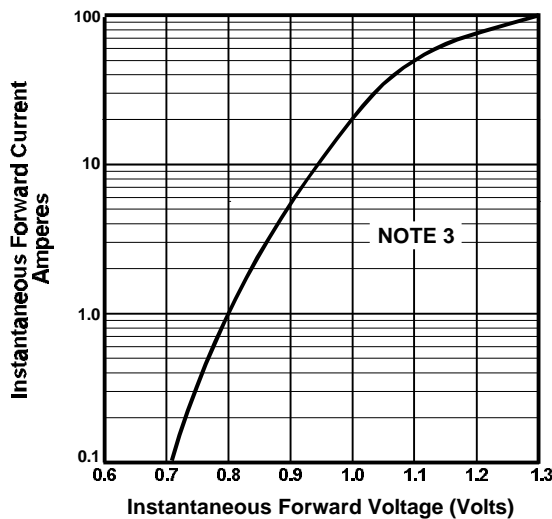

FIGURE 3. TYPICAL FORWARD CHARACTERISTIC PER DIODE

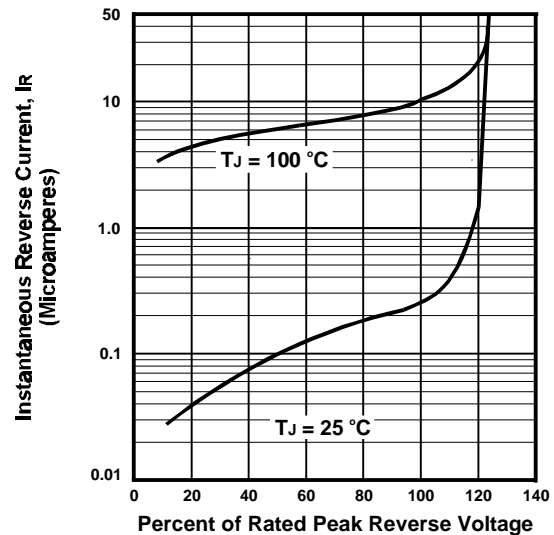

FIGURE 4. TYPICAL REVERSE CHARACTERISTICS

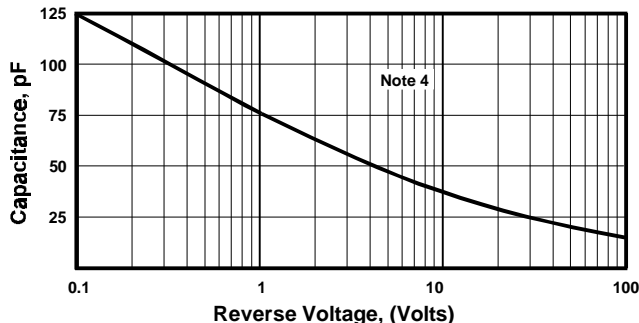
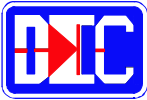

FIGURE 5. TYPICAL JUNCTION CAPACITANCE PER DIODE

NOTES

- (1) Case Temperature, T_c . With Bridge Mounted on 2.0" x 1.6" x 0.3" Thick (5cm x 4cm x 0.8cm) Aluminum Plate
 Ambient Temperature, T_A . With Bridge Mounted on PC Board With 0.5" Sq. (12mm Sq.) Pads and Bridge Lead Length of 0.375" (9.5mm)
- (2) $T_J = 150^\circ\text{C}$
- (3) $T_J = 25^\circ\text{C}$; Pulse Width = 300 μSec ; 1% Duty Cycle
- (4) $T_J = 25^\circ\text{C}$; $f = 1\text{ MHz}$; $V_{sig} = 50\text{mVp-p}$



5 AMP SILICON BRIDGE RECTIFIERS

FEATURES

- VOID FREE VACUUM DIE SOLDERING FOR MAXIMUM MECHANICAL STRENGTH AND HEAT DISSIPATION (Solder Voids: Typical < 2%, Max. < 10% of Die Area)
- BUILT-IN STRESS RELIEF MECHANISM FOR SUPERIOR RELIABILITY AND PERFORMANCE
- SURGE OVERLOAD RATING TO 200 AMPS PEAK
- IDEAL FOR PRINTED CIRCUIT BOARD APPLICATIONS
- RELIABLE LOW-COST MOLDED PLASTIC CONSTRUCTION

MECHANICAL DATA

- Case: Molded plastic, U/L Flammability Rating 94V-0
- Terminals: Round silver plated pins
- Soldering: Per MIL-STD 202 Method 208 guaranteed
- Polarity: Marked on case
- Mounting Position: Any
- Weight: 0.38 Ounces (10.6 Grams)

MECHANICAL SPECIFICATION

SB5 PACKAGE SHOWN ACTUAL SIZE

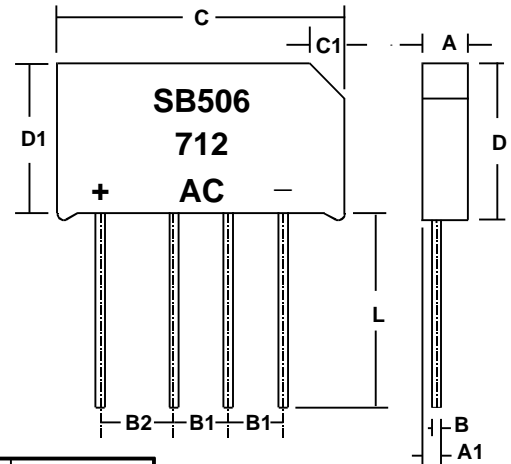

SYM	MILLIMETERS		INCHES	
	TYP	MAX	TYP	MAX
A	6.4		0.250	
A1	2.06		0.070	
B	1.27		0.05	
B1	7.6		0.300	
B2	10.2		0.400	
C	39.9		1.570	
C1	4.8		0.188	
D	21.7		0.855	
D1		21.0		0.820
L	25.4*		1.0*	

* This measurement is a "Minimum"

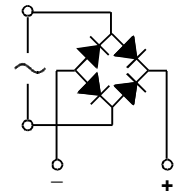

SERIES SB500 - SB510

MAXIMUM RATINGS & ELECTRICAL CHARACTERISTICS

Ratings at 25 °C ambient temperature unless otherwise specified.
 Single phase, half wave, 60Hz, resistive or inductive load.
 For capacitive loads, derate current by 20%.

PARAMETER (TEST CONDITIONS)	SYMBOL	RATINGS								UNITS
		SB 500	SB 501	SB 502	SB 504	SB 506	SB 508	SB 510		
Series Number										
Maximum DC Blocking Voltage	V _{RM}	50	100	200	400	600	800	1000		VOLTS
Maximum RMS Voltage	V _{RMS}	35	70	140	280	420	560	700		
Maximum Peak Recurrent Reverse Voltage	V _{RRM}	50	100	200	400	600	800	1000		
Average Forward Rectified Current @ T _A = 55° C	I _O	5								AMPS
Peak Forward Surge Current. Single 60Hz Half-Sine Wave Superimposed on Rated Load (JEDEC Method). T _J = 150° C	I _{FSM}	200								
Maximum Forward Voltage (Per Diode) at 5 Amps DC	V _{FM}	1.0 (Typical < 0.95)								VOLTS
Maximum Average DC Reverse Current @ T _A = 25° C	I _{RM}	5								μA
At Rated DC Blocking Voltage @ T _A = 100° C		0.5								mA
Typical Thermal Resistance Junction to Ambient (Note 1)	R _{θJA}	17								°C/W
Junction to Lead (Note 1)	R _{θJL}	3.3								
Junction Operating Temperature Range	T _J , T _{STG}	-55 to +150								°C

NOTES: (1) Unit mounted on 3.0" sq. x 0.11" (7.5cm sq. x 0.3cm) aluminum plate

3.01 05ab

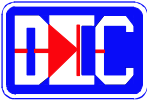

5 AMP SILICON BRIDGE RECTIFIERS

RATING & CHARACTERISTIC CURVES FOR SERIES SB500 - SB510

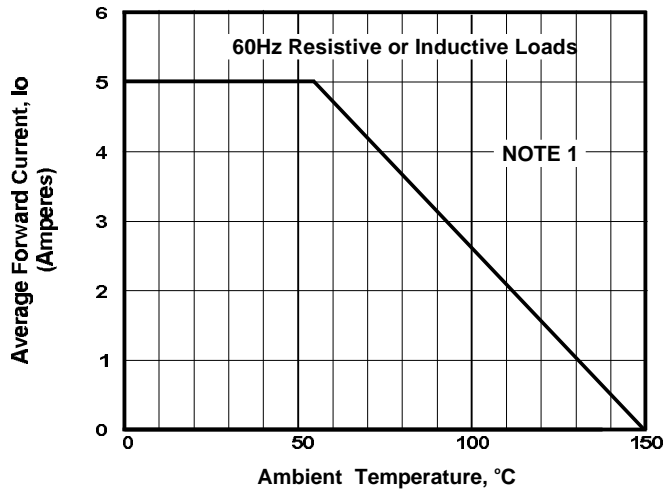

FIGURE 1. FORWARD CURRENT DERATING CURVE

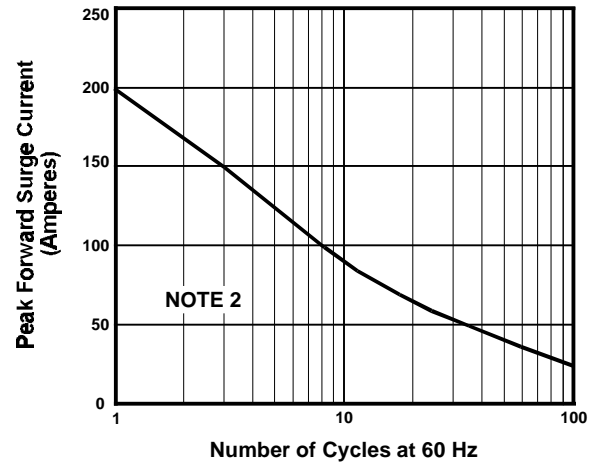

FIGURE 2. MAXIMUM NON-REPETITIVE SURGE CURRENT

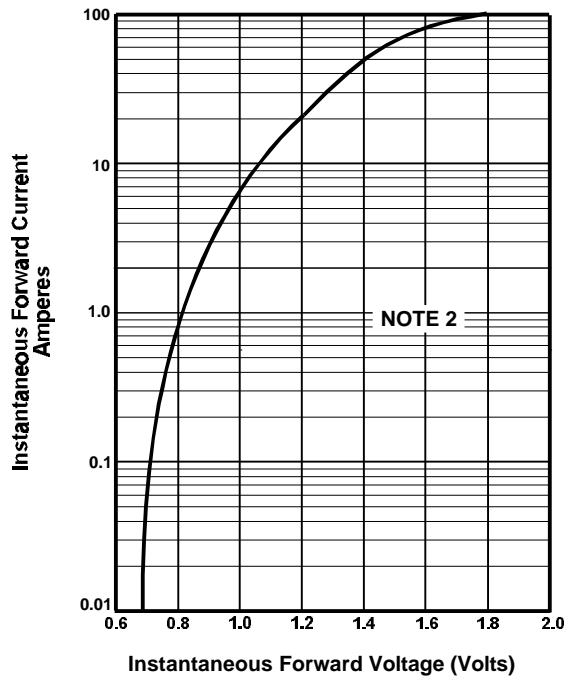

FIGURE 3. TYPICAL FORWARD CHARACTERISTIC PER DIODE

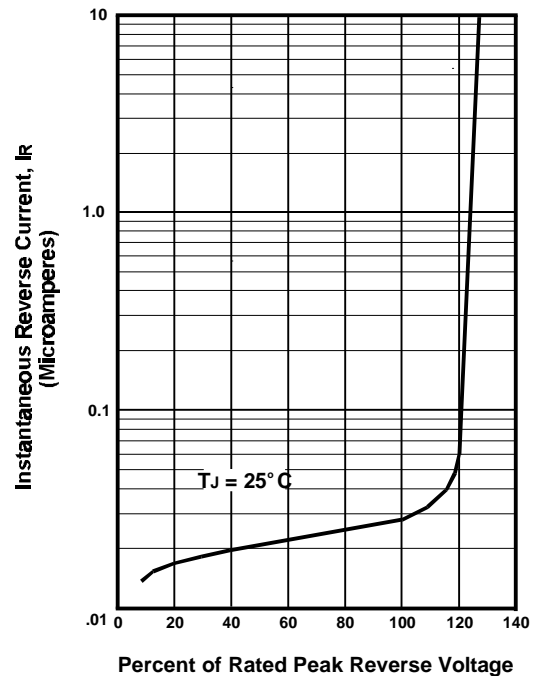
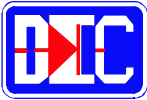

FIGURE 4. TYPICAL REVERSE CHARACTERISTICS

NOTES

- (1) Bridge Mounted on 3.0" sq. x 0.11" (7.5cm sq. x 0.3cm) Aluminum Plate
- (2) $T_J = 150^\circ\text{C}$
- (3) $T_J = 25^\circ\text{C}$; Pulse Width = 300 μSec ; 1% Duty Cycle



6 AMP SILICON BRIDGE RECTIFIERS

FEATURES

- **VOID FREE VACUUM DIE SOLDERING FOR MAXIMUM MECHANICAL STRENGTH AND HEAT DISSIPATION (Solder Voids: Typical < 2%, Max. < 10% of Die Area)**
- **BUILT-IN STRESS RELIEF MECHANISM FOR SUPERIOR RELIABILITY AND PERFORMANCE**
- **SURGE OVERLOAD RATING TO 250 AMPS PEAK**
- **IDEAL FOR PRINTED CIRCUIT BOARD APPLICATIONS**
- **THRU-HOLE FOR EASY HEAT SINK MOUNTING**
- **UL RECOGNIZED - FILE #E124962**

MECHANICAL DATA

- **Case:** Molded plastic, U/L Flammability Rating 94V-0
- **Terminals:** Round silver plated pins
- **Soldering:** Per MIL-STD 202 Method 208 guaranteed
- **Polarity:** Marked on case
- **Mounting Position:** Any. Max. mounting torque = 5 in lb
- **Weight:** 0.3 Ounces (8 Grams)

MECHANICAL SPECIFICATION

SBU PACKAGE SHOWN ACTUAL SIZE

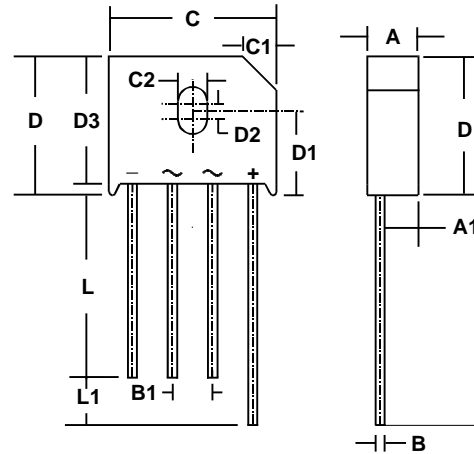

SYM	MILLIMETERS		INCHES	
	MIN	MAX	MIN	MAX
A	6.6	7.1	0.260	0.280
A1	4.7	5.2	0.185	0.205
B	1.22	1.32	0.048	0.052
B1	4.57	5.59	0.180	0.220
C	22.7	23.24	0.895	0.915
C1	4.2	4.7	0.165	0.185
C2	3.6	4.1	0.140	0.160
D	n/a	19.3	n/a	0.760
D1	10.3	11.3	0.405	0.455
D2	1.7	2.2	0.065	0.085
D3	16.5	17.8	0.660	0.700
L	25.4	n/a	1.0	n/a
L1	4.57	6.8	0.180	0.260

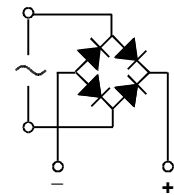

SERIES SBU6A - SBU6M

MAXIMUM RATINGS & ELECTRICAL CHARACTERISTICS

Ratings at 25 °C ambient temperature unless otherwise specified. Single phase, 60Hz, resistive or inductive load. For capacitive loads, derate current by 20%.

PARAMETER (TEST CONDITIONS)	SYMBOL	RATINGS							UNITS
		SBU 6A	SBU 6B	SBU 6D	SBU 6G	SBU 6J	SBU 6K	SBU 6M	
Series Number									
Maximum DC Blocking Voltage	V _{RM}	50	100	200	400	600	800	1000	VOLTS
Maximum RMS Voltage	V _{RMS}	35	70	140	280	420	560	700	
Maximum Peak Recurrent Reverse Voltage	V _{RRM}	50	100	200	400	600	800	1000	
Average Forward Rectified Current <small>T_c = 100° C (Notes 1, 3) T_A = 40° C (Note 2)</small>	I _o	6 6							AMPS
Peak Forward Surge Current. Single 60Hz Half-Sine Wave Superimposed on Rated Load (JEDEC Method). T _J = 150° C	I _{FSM}	250							
Maximum Forward Voltage (Per Diode) at 6 Amps DC	V _{FM}	0.95 (Typical < 0.90)							VOLTS
Maximum Average DC Reverse Current At Rated DC Blocking Voltage	I _{RM}	5 (Typical < 0.5μA) 1							μA mA
Typical Thermal Resistance Junction to Ambient (Note 2) Junction to Case (Note 3)	R _{θJA} R _{θJC}	16.0 3.1							°C/W
Operating and Storage Temperature Range	T _J , T _{STG}	-55 to +150							°C

NOTES: (1) Bridge mounted on 2.6" x 1.4" x 0.06" thick (6.5cm x 3.5cm x 0.15cm) aluminum plate
 (2) Bridge mounted on PC Board with 0.5" sq. (12mm sq.) copper pads and bridge lead length of 0.375" (9.5mm)
 (3) Bolt bridge on heat sink with #6 screw, using silicon thermal compound between bridge and mounting surface for maximum heat transfer.

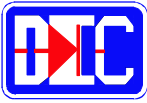

6 AMP SILICON BRIDGE RECTIFIERS

RATING & CHARACTERISTIC CURVES FOR SERIES SBU6A - SBU6M

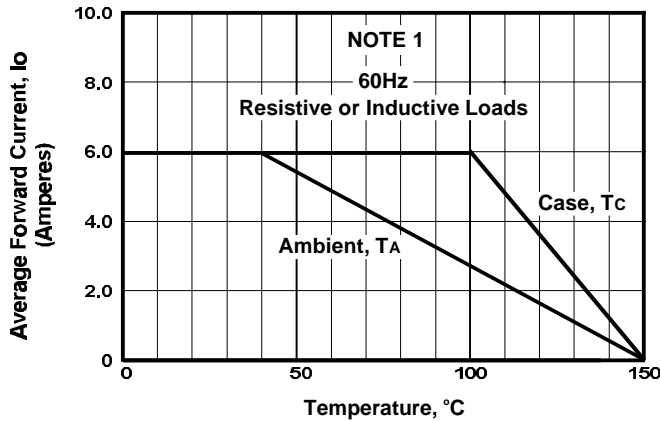

FIGURE 1. FORWARD CURRENT DERATING CURVE

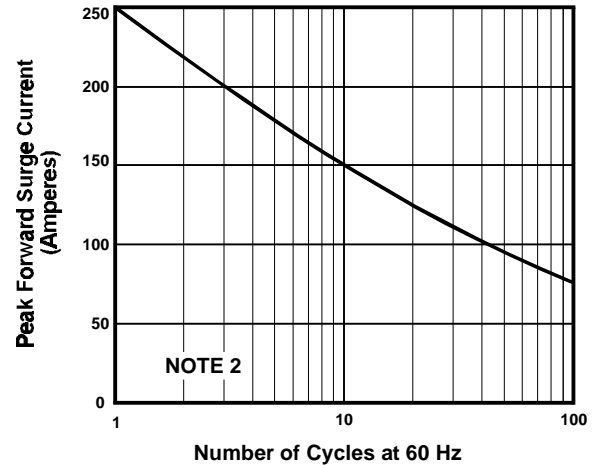

FIGURE 2. MAXIMUM NON-REPETITIVE SURGE CURRENT

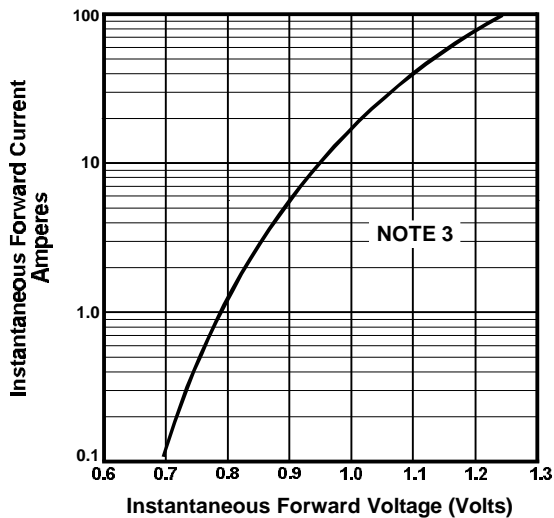

FIGURE 3. TYPICAL FORWARD CHARACTERISTIC PER DIODE

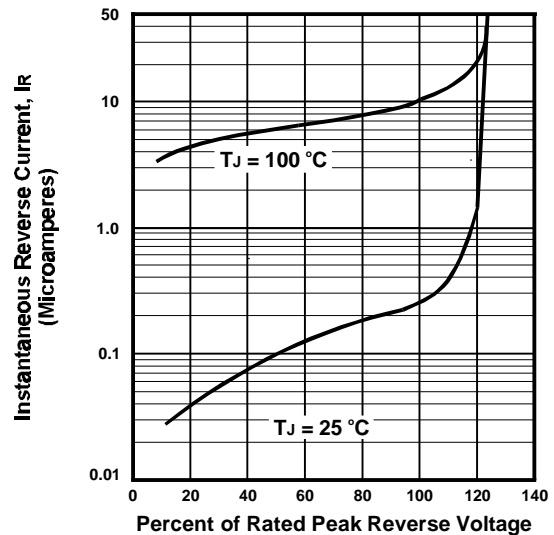

FIGURE 4. TYPICAL REVERSE CHARACTERISTICS

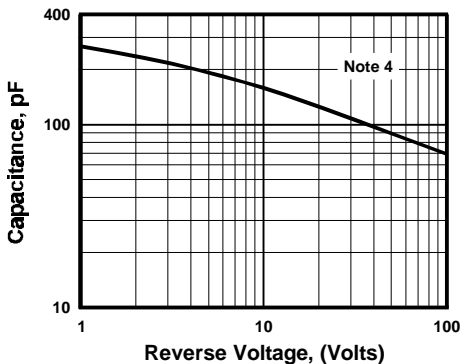
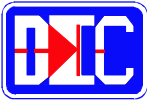

FIGURE 5. TYPICAL JUNCTION CAPACITANCE PER DIODE

NOTES

- (1) Case Temperature, T_c , With Bridge Mounted on 2.6" x 1.4" x 0.06" Thick (6.5cm x 3.5cm x 0.15cm) Aluminum Plate

 Ambient Temperature, T_A , With Bridge Mounted on PC Board With 0.5" Sq. (12mm Sq.) Pads and Bridge Lead Length of 0.375" (9.5mm)
- (2) $T_J = 150^\circ\text{C}$
- (3) $T_J = 25^\circ\text{C}$; Pulse Width = 300 μSec ; 1% Duty Cycle
- (4) $T_J = 25^\circ\text{C}$; $f = 1\text{ MHz}$; $V_{sig} = 50\text{mVp-p}$



6 AMP SILICON BRIDGE RECTIFIERS

FEATURES

- **VOID FREE VACUUM DIE SOLDERING FOR MAXIMUM MECHANICAL STRENGTH AND HEAT DISSIPATION (Solder Voids: Typical < 2%, Max. < 10% of Die Area)**
- **BUILT-IN STRESS RELIEF MECHANISM FOR SUPERIOR RELIABILITY AND PERFORMANCE**
- **SURGE OVERLOAD RATING TO 250 AMPS PEAK**
- **UL RECOGNIZED - FILE #E124962**

MECHANICAL DATA

- **Case:** Molded plastic, U/L Flammability Rating 94V-0
- **Terminals:** Round silver plated copper pins
- **Soldering:** Per MIL-STD 202 Method 208 guaranteed
- **Polarity:** Marked on side of case; positive lead at beveled corner
- **Mounting Position:** Any. Through hole provided for #6 screw
- **Weight:** 0.13 Ounces (3.6 Grams)

MECHANICAL SPECIFICATION

ACTUAL SIZE

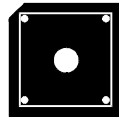

SERIES DB600 - DB610 and ADB604 - ADB608

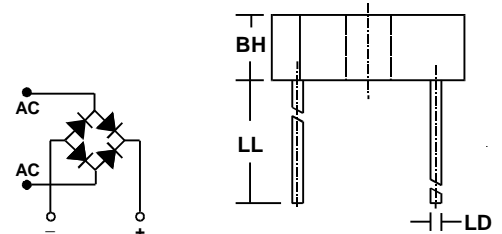

SYM	MILLIMETERS		INCHES	
	MIN	MAX	MIN	MAX
BL	14.7	15.7	0.58	0.62
BH	5.8	6.9	0.23	0.27
D1	10.3	11.3	0.405	0.445
LL	19.0	n/a	0.75	n/a
LD	1.0	1.1	0.039	0.042

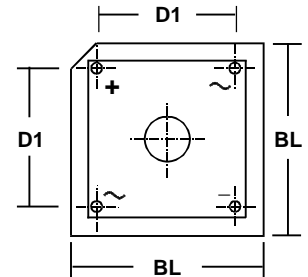

MAXIMUM RATINGS & ELECTRICAL CHARACTERISTICS

Ratings at 25 °C ambient temperature unless otherwise specified. Single phase, 60Hz, resistive or inductive load. For capacitive loads, derate current by 20%.

PARAMETER (TEST CONDITIONS)	SYMBOL	RATINGS										UNITS
		CONTROLLED AVALANCHE			NON-CONTROLLED AVALANCHE							
		ADB 604	ADB 606	ADB 608	DB 600	DB 601	DB 602	DB 604	DB 606	DB 608	DB 610	
Series Number												
Maximum DC Blocking Voltage	V _{RM}											
Working Peak Reverse Voltage	V _{RWM}	400	600	800	50	100	200	400	600	800	1000	VOLTS
Maximum Peak Recurrent Reverse Voltage	V _{RRM}											
RMS Reverse Voltage	V _R (RMS)	280	420	560	35	70	140	280	420	560	700	
Power Dissipation in V _(BR) Region for 100 μS Square Wave	P _{RM}	400			n/a							
Continuous Power Dissipation in V _(BR) Region @ T _{HS} =80 °C (Heat Sink Temp)	P _R	2			n/a							WATTS
Thermal Energy (Rating for Fusing) t < 8.3 mSec	I ² t	127										AMPS ² SEC
Peak Forward Surge Current. Single 60Hz Half-Sine Wave Superimposed on Rated Load (JEDEC Method). T _J = 150° C	I _{FSM}	250										AMPS
Average Forward Rectified Current @ T _c = 50° C (Notes 1, 2) @ T _A = 40° C (Note 3)	I _o	6 3										AMPS
Junction Operating and Storage Temperature Range	T _J , T _{STG}	-55 to +150										°C
Minimum Avalanche Voltage	V _(BR) Min	450	650	850	n/a							
Maximum Avalanche Voltage	V _(BR) Max	900	1100	1300	n/a							VOLTS
Maximum Forward Voltage (Per Diode) at 3 Amps DC	V _{FM}	0.95 (Typical < 0.90)										
Typical Junction Capacitance (Note 4)	C _J	186	90		186			90				
Maximum Reverse Current at Rated V _{RM} @ T _A = 25° C @ T _A = 100° C	I _{RM}	5 (Typical < 0.5μA) 0.5										μA mA
Minimum Insulation Breakdown Voltage (Circuit to Case)	V _{ISO}	2000										VOLTS
Typical Thermal Resistance Junction to Ambient (Note 3) Junction to Case (Note 2)	R _{θJA} R _{θJC}	16.0 5.7										°C/W

NOTES: (1) Bolt bridge on heat sink with #6 screw, using silicon thermal compound between bridge and mounting surface for maximum heat transfer.
 (2) Bridge mounted on 4.0" sq. x 0.11" thick (10.5cm sq. x 0.3cm) aluminum plate
 (3) Bridge mounted on PC Board with 0.5" sq. (12mm sq.) copper pads and bridge lead length of 0.375" (9.5mm)
 (4) Measured at 1.0 MHz and applied reverse voltage of 4.0 Volts

3.01 0560

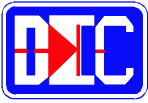

6 AMP SILICON BRIDGE RECTIFIERS

RATING & CHARACTERISTIC CURVES FOR SERIES DB600 - DB610 and SERIES ADB604 - ADB608

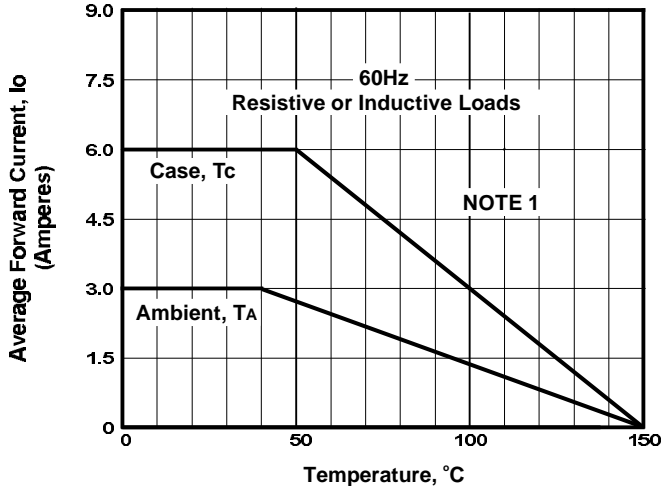

FIGURE 1. FORWARD CURRENT DERATING CURVE

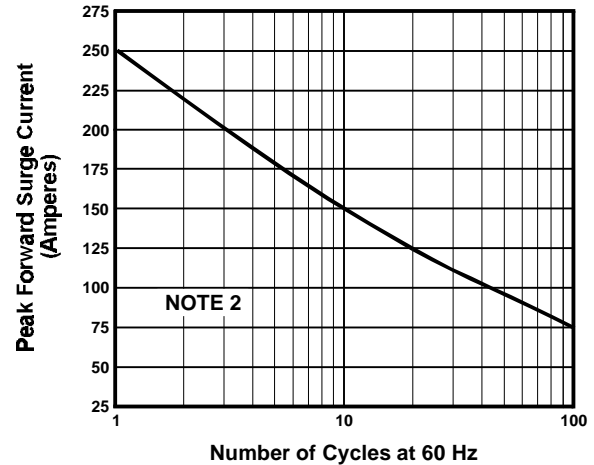

FIGURE 2. MAXIMUM NON-REPETITIVE SURGE CURRENT

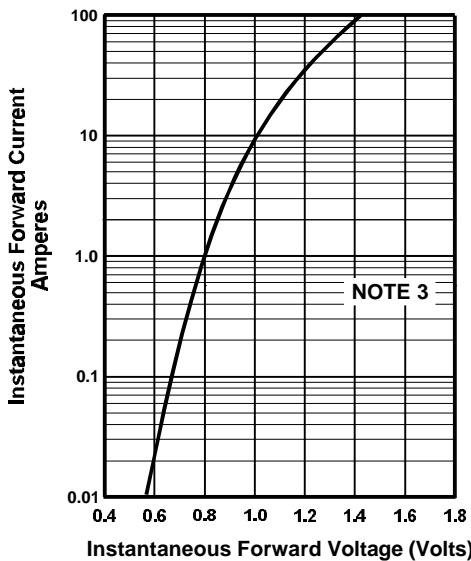

FIGURE 3. TYPICAL FORWARD CHARACTERISTIC PER DIODE

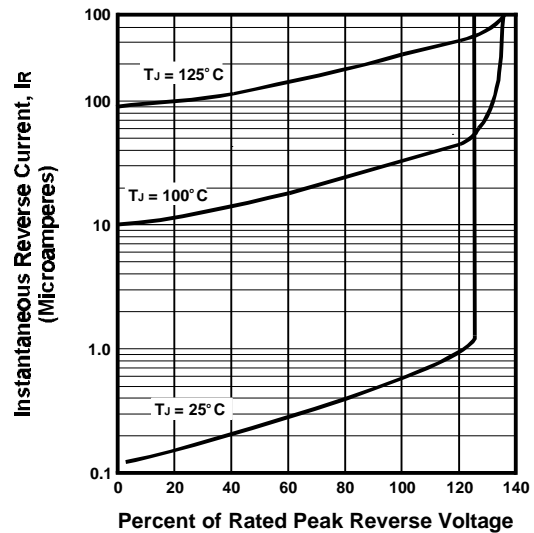

FIGURE 4. TYPICAL REVERSE CHARACTERISTICS PER DIODE

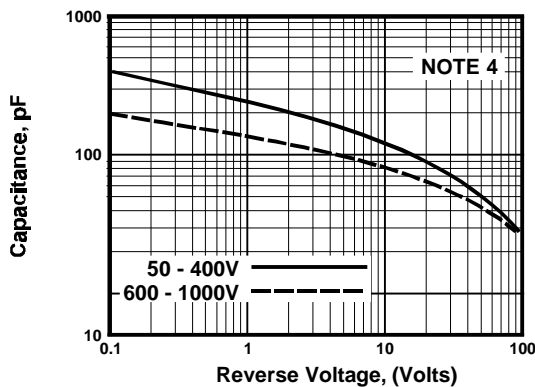
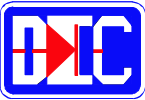

FIGURE 5. TYPICAL JUNCTION CAPACITANCE PER DIODE

NOTES

- (1) Case Temperature, T_c , With Bridge Mounted on 4" Sq. x 0.11" Thick (10.5cm Sq. x 0.3cm) Aluminum Plate
 Ambient Temperature, T_A , With Bridge Mounted on PC Board With 0.5" Sq. (12mm Sq.) Pads and Lead Length of, 0.375" (9.5mm)
- (2) $T_J = 150^\circ C$
- (3) $T_J = 25^\circ C$; Pulse Width = 300 μ Sec; 1% Duty Cycle
- (4) $T_J = 25^\circ C$; $f = 1$ MHz; $V_{sig} = 50$ mVp-p



6 AMP SILICON BRIDGE RECTIFIERS

FEATURES

- VOID FREE VACUUM DIE SOLDERING FOR MAXIMUM MECHANICAL STRENGTH AND HEAT DISSIPATION (Solder Voids: Typical < 2%, Max. < 10% of Die Area)
- BUILT-IN STRESS RELIEF MECHANISM FOR SUPERIOR RELIABILITY AND PERFORMANCE
- Unique structure - DC leads on one side, AC leads on the opposite side
- Ideal for DC motor related applications
- **UL RECOGNIZED - FILE #E141956**

MECHANICAL DATA

- Case: Molded plastic, U/L Flammability Rating 94V-0
- Terminals: Round silver plated copper pins/faston connectors
- Soldering: Per MIL-STD 202 Method 208 guaranteed
- Polarity: Marked on case
- Mounting Position: Any.
- Weight: 0.13 Ounces (3.6 Grams)

MECHANICAL SPECIFICATION

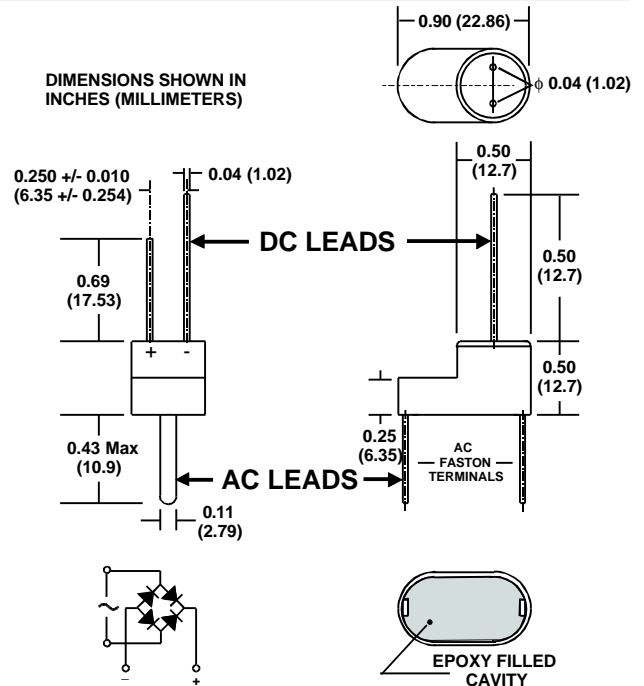

MAXIMUM RATINGS & ELECTRICAL CHARACTERISTICS

Ratings at 25°C ambient temperature unless otherwise specified.
 Single phase, half wave, 60Hz, resistive or inductive load.
 For capacitive loads, derate current by 20%.

PARAMETER (TEST CONDITIONS)	SYMBOL	RATINGS										UNITS
		CONTROLLED AVALANCHE			NON-CONTROLLED AVALANCHE							
Series Number		AHBU 604	AHBU 606	AHBU 608	HBU 600	HBU 601	HBU 602	HBU 604	HBU 606	HBU 608	HBU 610	
Maximum DC Blocking Voltage	V _{RM}											VOLTS
Working Peak Reverse Voltage	V _{RWM}	400	600	800	50	100	200	400	600	800	1000	
Maximum Peak Recurrent Reverse Voltage	V _{RRM}											
RMS Reverse Voltage	V _R (RMS)	280	420	560	35	70	140	280	420	560	700	
Power Dissipation in V _(BR) Region for 100 μS Square Wave	P _{RM}	400			n/a							WATTS
Continuous Power Dissipation in V _(BR) Region @ T _{HS} =80°C (Heat Sink Temp)	P _R	2			n/a							
Thermal Energy (Rating for Fusing)	I ² t	127										AMPS ² SEC
Peak Forward Surge Current. Single 60Hz Half-Sine Wave Superimposed on Rated Load (JEDEC Method). T _J = 150°C	I _{FSM}	250										AMPS
Average Forward Rectified Current @ T _c = 50°C @ T _A = 40°C	I _o	6 3										
Junction Operating and Storage Temperature Range	T _J , T _{STG}	-55 to +150										°C
Minimum Avalanche Voltage	V _(BR) Min	450	650	850	n/a							VOLTS
Maximum Avalanche Voltage	V _(BR) Max	900	1100	1300	n/a							
Maximum Forward Voltage (Per Diode) at 6 Amps DC	V _{FM}	0.95 (Typical < 0.90)										
Maximum Reverse Current at Rated V _{RM} @ T _A = 25°C @ T _A = 100°C	I _{RM}	5 1										μA mA
Minimum Insulation Breakdown Voltage (Circuit to Case)	V _{ISO}	2000										VOLTS
Typical Thermal Resistance (on Heat Sink) Junction to Ambient	R _{θJA}	16.0										°C/W
Junction to Case	R _{θJC}	5.7										

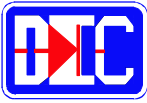

6 AMP SILICON BRIDGE RECTIFIERS

RATING & CHARACTERISTIC CURVES FOR SERIES HBU600 - HBU610 and SERIES AHBU604 - AHBU608

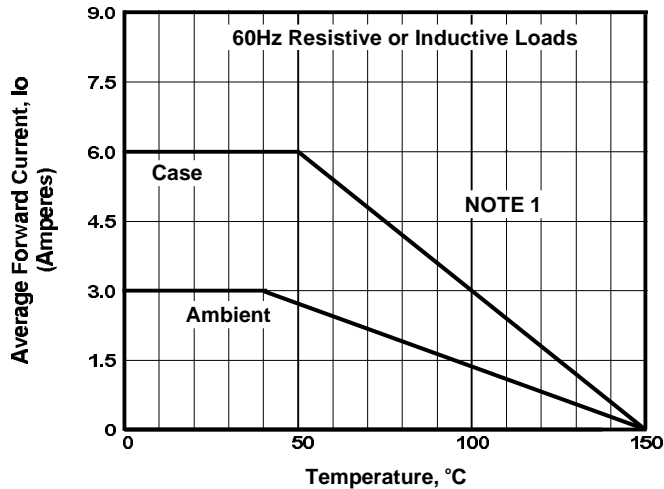

FIGURE 1. FORWARD CURRENT DERATING CURVE

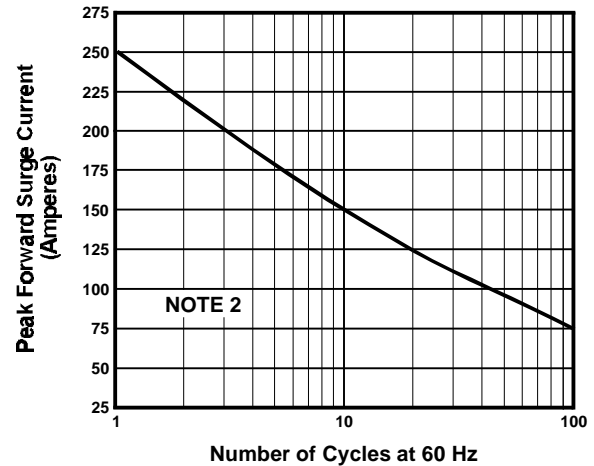

FIGURE 2. MAXIMUM NON-REPETITIVE SURGE CURRENT

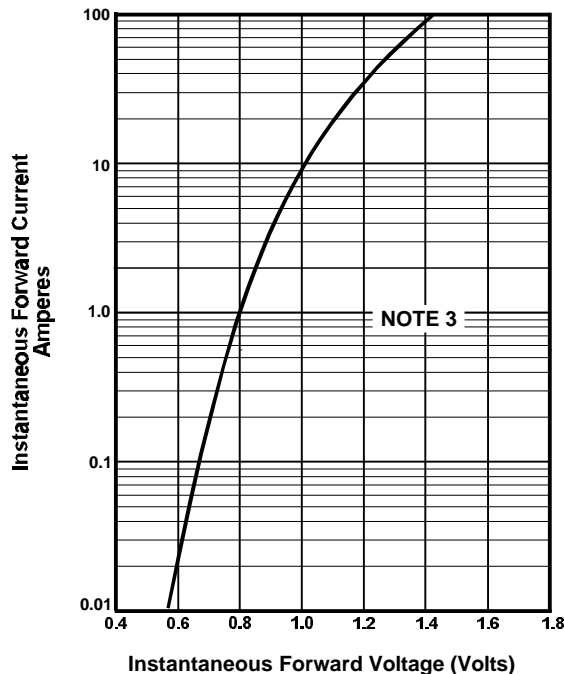

FIGURE 3. TYPICAL FORWARD CHARACTERISTIC PER DIODE

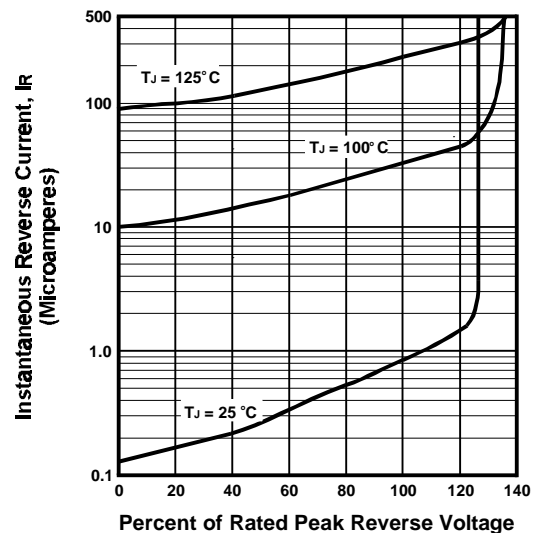
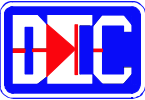

FIGURE 4. TYPICAL REVERSE CHARACTERISTICS PER DIODE

NOTES

- (1) Ambient = Ambient temperature, T_A . P.C. Board mounting with 0.375" (9.5 mm) Lead lengths
 Case = Case Temperature, T_C . Mounted on aluminum plate 5.5" x 6.0" x 0.11" thick (14cm x 15cm x 0.3 cm)
- (2) $T_J = 150^\circ\text{C}$
- (3) $T_J = 25^\circ\text{C}$; Pulse Width = 300 μSec ; 1% Duty Cycle



8 AMP SILICON BRIDGE RECTIFIERS

FEATURES

- VOID FREE VACUUM DIE SOLDERING FOR MAXIMUM MECHANICAL STRENGTH AND HEAT DISSIPATION (Solder Voids: Typical < 2%, Max. < 10% of Die Area)
- BUILT-IN STRESS RELIEF MECHANISM FOR SUPERIOR RELIABILITY AND PERFORMANCE
- SURGE OVERLOAD RATING TO 300 AMPS PEAK
- THRU-HOLE FOR EASY HEAT SINK MOUNTING
- **UL RECOGNIZED - FILE #E124962**

MECHANICAL SPECIFICATION

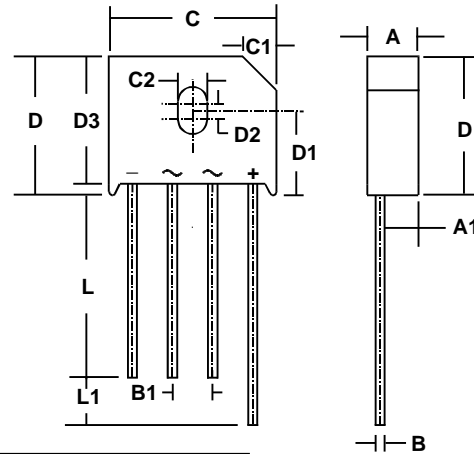

MECHANICAL DATA

- Case: Molded plastic, U/L Flammability Rating 94V-0
- Terminals: Round silver plated pins
- Soldering: Per MIL-STD 202 Method 208 guaranteed
- Polarity: Marked on case
- Mounting Position: Any. Max. mounting torque = 5 in lb
- Weight: 0.3 Ounces (8 Grams)

SYM	MILLIMETERS		INCHES	
	MIN	MAX	MIN	MAX
A	6.6	7.1	0.260	0.280
A1	4.7	5.2	0.185	0.205
B	1.22	1.32	0.048	0.052
B1	4.57	5.59	0.180	0.220
C	22.7	23.24	0.895	0.915
C1	4.2	4.7	0.165	0.185
C2	3.6	4.1	0.140	0.160
D	n/a	19.3	n/a	0.760
D1	10.3	11.3	0.405	0.455
D2	1.7	2.2	0.065	0.085
D3	16.5	17.8	0.660	0.700
L	25.4	n/a	1.0	n/a
L1	4.57	6.8	0.180	0.260

SERIES SBU8A - SBU8M

MAXIMUM RATINGS & ELECTRICAL CHARACTERISTICS

Ratings at 25 °C ambient temperature unless otherwise specified. Single phase, 60Hz, resistive or inductive load. For capacitive loads, derate current by 20%.

PARAMETER (TEST CONDITIONS)	SYMBOL	RATINGS							UNITS
		SBU 8A	SBU 8B	SBU 8D	SBU 8G	SBU 8J	SBU 8K	SBU 8M	
Series Number									
Maximum DC Blocking Voltage	V _{RM}	50	100	200	400	600	800	1000	VOLTS
Maximum RMS Voltage	V _{RMS}	35	70	140	280	420	560	700	
Maximum Peak Recurrent Reverse Voltage	V _{RRM}	50	100	200	400	600	800	1000	
Average Forward Rectified Current T _c = 100° C (Notes 1, 3)	I _o	8							AMPS
Peak Forward Surge Current. Single 60Hz Half-Sine Wave Superimposed on Rated Load (JEDEC Method). T _J = 150° C	I _{FSM}	300							
Maximum Forward Voltage (Per Diode) at 8 Amps DC	V _{FM}	0.95 (Typ. 0.90)							VOLTS
Maximum Average DC Reverse Current At Rated DC Blocking Voltage	I _{RM}	5 (Typical < 0.5µA) 0.5							µA mA
Typical Thermal Resistance Junction to Ambient (Note 2) Junction to Case (Note 1)	R _{θJA} R _{θJC}	16 3							°C/W
Operating and Storage Temperature Range	T _J , T _{STG}	-55 to +150							°C

NOTES: (1) Bridge mounted on 3.2" sq. x 0.12" thick (8.2cm sq. x 0.3cm) aluminum plate
 (2) Bridge mounted on PC Board with 0.5" sq. (12mm sq.) copper pads and bridge lead length of 0.375" (9.5mm)
 (3) Bolt bridge on heat sink with #6 screw, using silicon thermal compound between bridge and mounting surface for maximum heat transfer.

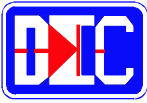

8 AMP SILICON BRIDGE RECTIFIERS

RATING & CHARACTERISTIC CURVES FOR SERIES SBU8A - SBU8M

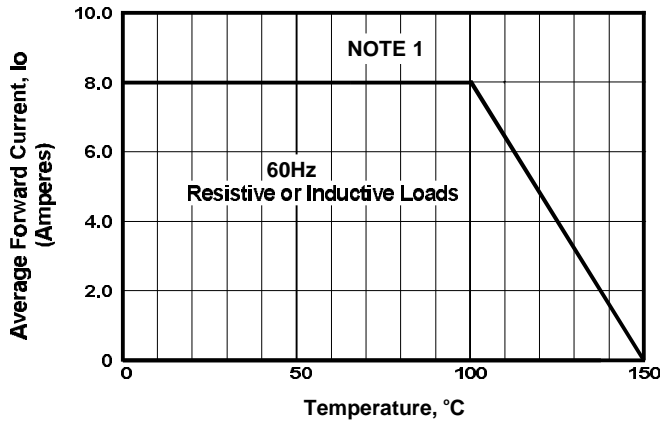

FIGURE 1. FORWARD CURRENT DERATING CURVE

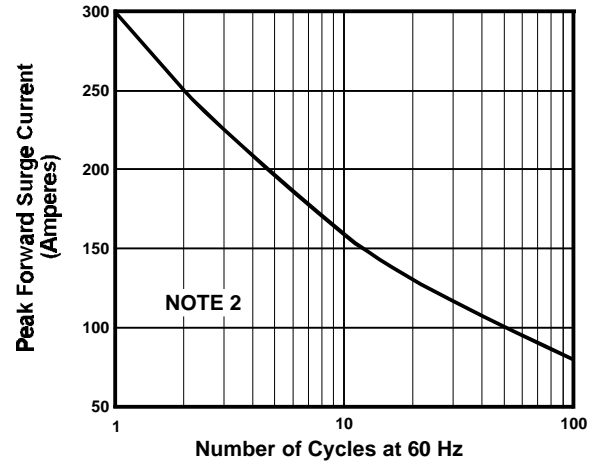

FIGURE 2. MAXIMUM NON-REPETITIVE SURGE CURRENT

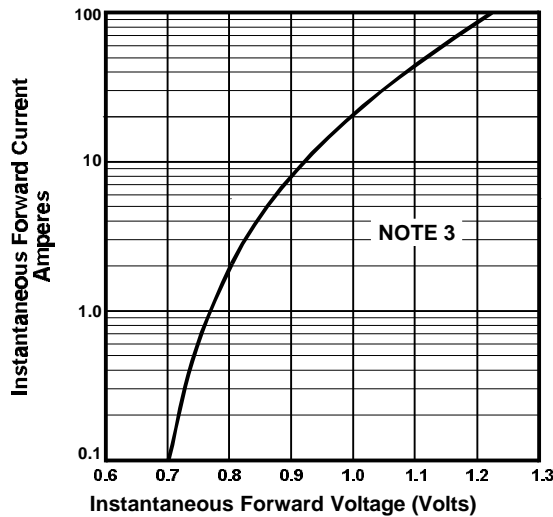

FIGURE 3. TYPICAL FORWARD CHARACTERISTIC PER DIODE

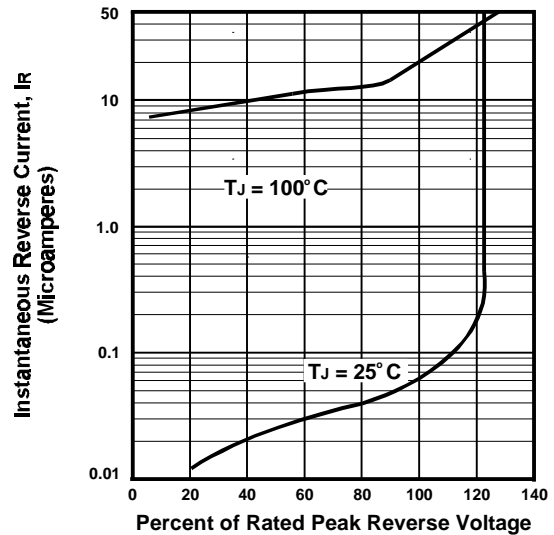

FIGURE 4. TYPICAL REVERSE CHARACTERISTICS

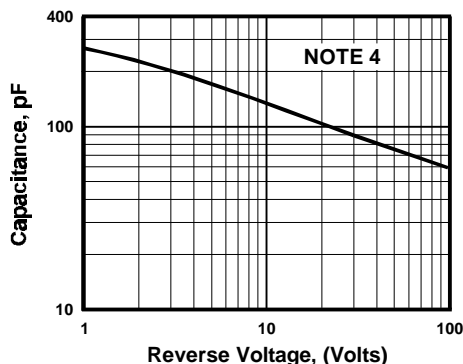
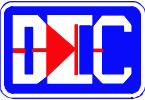

FIGURE 5. TYPICAL JUNCTION CAPACITANCE PER DIODE

NOTES

- (1) Case Temperature, T_c , With Bridge Mounted on 3.2" Sq. x 0.12" Thick (8.2cm Sq. x 0.3cm) Aluminum Plate
- (2) $T_J = 150^\circ\text{C}$
- (3) $T_J = 25^\circ\text{C}$; Pulse Width = 300 μSec ; 1% Duty Cycle
- (4) $T_J = 25^\circ\text{C}$; $f = 1\text{ MHz}$; $V_{sig} = 50\text{mVp-p}$



8 AMP SILICON BRIDGE RECTIFIERS

FEATURES

- **VOID FREE VACUUM DIE SOLDERING FOR MAXIMUM MECHANICAL STRENGTH AND HEAT DISSIPATION (Solder Voids: Typical < 2%, Max. < 10% of Die Area)**
- **BUILT-IN STRESS RELIEF MECHANISM FOR SUPERIOR RELIABILITY AND PERFORMANCE**
- **SURGE OVERLOAD RATING TO 300 AMPS PEAK**
- **UL RECOGNIZED - FILE #E124962**

MECHANICAL DATA

- Case: Molded plastic, U/L Flammability Rating 94V-0
- Terminals: Round silver plated copper pins
- Soldering: Per MIL-STD 202 Method 208 guaranteed
- Polarity: Marked on side of case; positive lead at beveled corner
- Mounting Position: Any. Through hole provided for #6 screw
- Weight: 0.18 Ounces (5.4 Grams)

MECHANICAL SPECIFICATION

ACTUAL SIZE

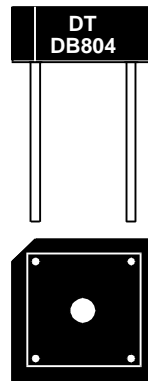

SERIES DB800-DB810 and ADB804-ADB808

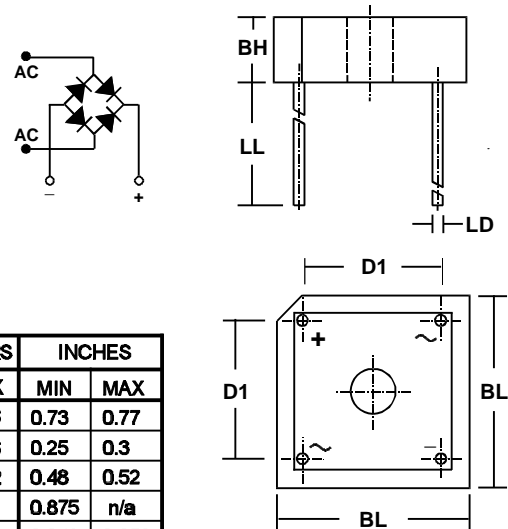

SYM	MILLIMETERS		INCHES	
	MIN	MAX	MIN	MAX
BL	18.5	19.6	0.73	0.77
BH	6.4	7.6	0.25	0.3
D1	12.2	13.2	0.48	0.52
LL	22.2	n/a	0.875	n/a
LD	1.2	1.3	0.048	0.052

MAXIMUM RATINGS & ELECTRICAL CHARACTERISTICS

Ratings at 25°C ambient temperature unless otherwise specified.
 Single phase, half wave, 60Hz, resistive or inductive load.
 For capacitive loads, derate current by 20%.

PARAMETER (TEST CONDITIONS)	SYMBOL	RATINGS										UNITS	
		CONTROLLED AVALANCHE			NON-CONTROLLED AVALANCHE								
		ADB 804	ADB 806	ADB 808	DB 800	DB 801	DB 802	DB 804	DB 806	DB 808	DB 810		
Series Number													
Maximum DC Blocking Voltage	V _{RM}											VOLTS	
Working Peak Reverse Voltage	V _{RWM}	400	600	800	50	100	200	400	600	800	1000		
Maximum Peak Recurrent Reverse Voltage	V _{RRM}												
RMS Reverse Voltage	V _R (RMS)	280	420	560	35	70	140	280	420	560	700		
Power Dissipation in V _(BR) Region for 100 μS Square Wave	P _{RM}	400			n/a							WATTS	
Continuous Power Dissipation in V _(BR) Region @ T _{HS} =80° C (Heat Sink Temp)	P _R	2			n/a								
Thermal Energy (Rating for Fusing)	I ² t	64										AMPS ² SEC	
Peak Forward Surge Current. Single 60Hz Half-Sine Wave Superimposed on Rated Load (JEDEC Method). T _J = 150° C	I _{FSM}	300										AMPS	
Average Forward Rectified Current @ T _C = 50° C (Note 1) @ T _A = 50° C (Note 2)	I _O	10 8											
Junction Operating and Storage Temperature Range	T _J , T _{STG}	-55 to +150										°C	
Minimum Avalanche Voltage	V _(BR) Min	450	650	850	n/a							VOLTS	
Maximum Avalanche Voltage	V _(BR) Max	900	1100	1300	n/a								
Maximum Forward Voltage (Per Diode) at 4 Amps DC	V _{FM}	0.95 (Typ. 0.90)											
Maximum Reverse Current at Rated V _{RM} @ T _A = 25° C @ T _A = 100° C	I _{RM}	5 1										μA mA	
Minimum Insulation Breakdown Voltage (Circuit to Case)	V _{ISO}	2000										VOLTS	
Typical Thermal Resistance	Junction to Ambient (Note 2)	R _{θJA}	12										°C/W
	Junction to Case (Note 1)	R _{θJC}	5										

NOTES: (1) Bridge mounted on 4.9" x 4.3" x 0.11" thick (12.4cm x 10.8cm x 0.3cm) aluminum plate
 (2) Bridge mounted on PC Board with 0.5" sq. (12mm sq.) copper pads and bridge lead length of 0.375" (9.5mm)
 (3) Bolt bridge on heat sink, using silicon thermal compound between bridge and mounting surface, for maximum heat transfer.

3.01 880b

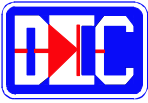

8 AMP SILICON BRIDGE RECTIFIERS

RATING & CHARACTERISTIC CURVES FOR SERIES DB800 - DB810 and SERIES ADB804 - ADB808

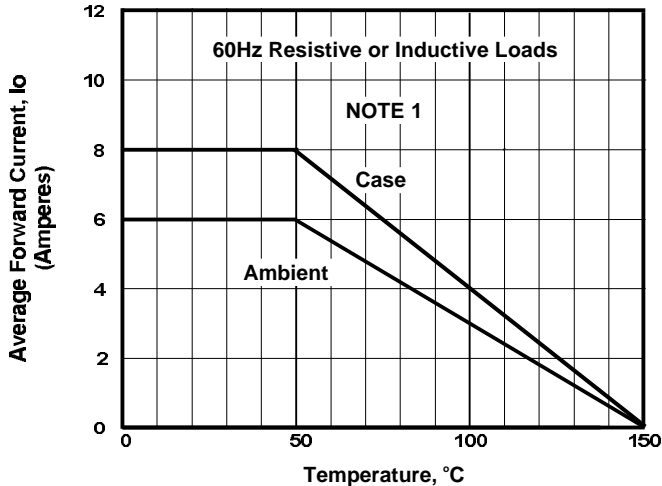

FIGURE 1. FORWARD CURRENT DERATING CURVE

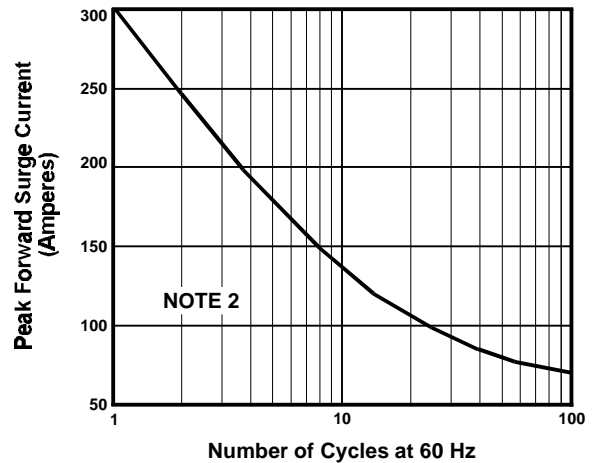

FIGURE 2. MAXIMUM NON-REPETITIVE SURGE CURRENT

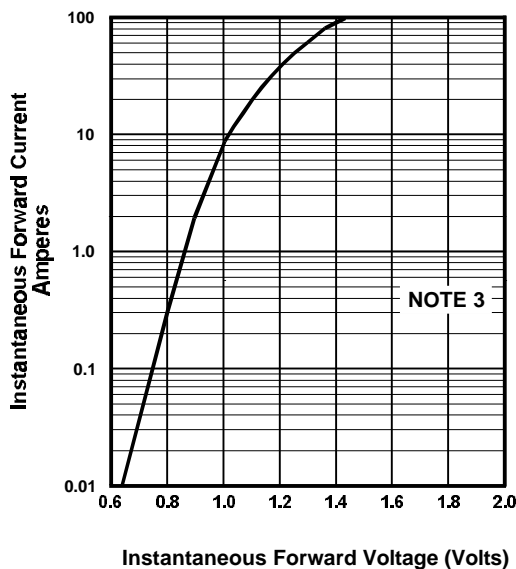

FIGURE 3. TYPICAL FORWARD CHARACTERISTIC PER DIODE

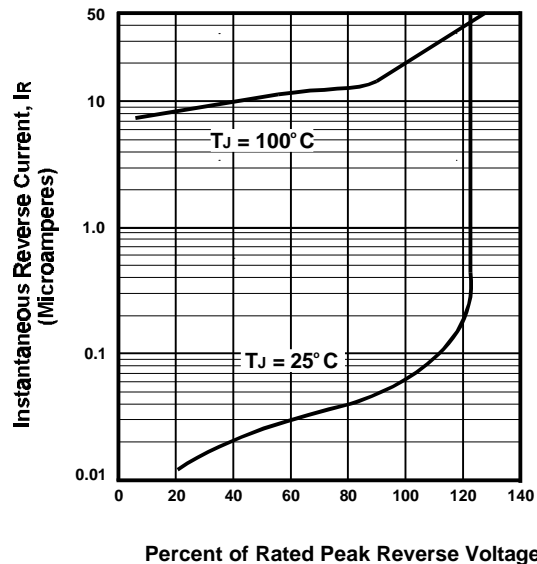

FIGURE 4. TYPICAL REVERSE CHARACTERISTICS

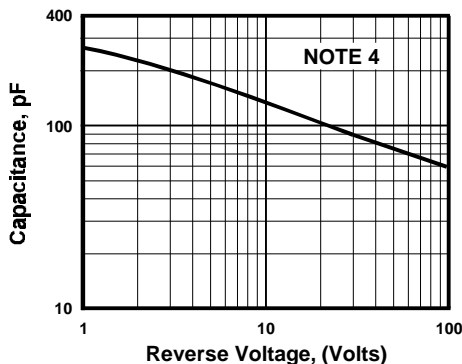

FIGURE 5. TYPICAL JUNCTION CAPACITANCE PER DIODE

NOTES

(1) Case Temperature, T_c , With Bridge Mounted on 4.9" x 4.3" x 0.11" Thick (12.4cm x 10.8cm x 0.3cm) Aluminum Plate

Ambient Temperature, T_A , With Bridge Mounted on PC Board With 0.5" Sq. (12mm Sq.) Copper Pads And Bridge Lead Length of 0.375" (9.5mm)

(2) $T_J = 150^\circ\text{C}$

(3) $T_J = 25^\circ\text{C}$; Pulse Width = 300 μSec ; 1% Duty Cycle

(4) $T_J = 25^\circ\text{C}$; $f = 1\text{ MHz}$; $V_{sig} = 50\text{mVp-p}$

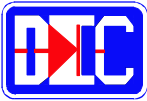

10 AMP SILICON BRIDGE RECTIFIERS

FEATURES

- **VOID FREE VACUUM DIE SOLDERING FOR MAXIMUM MECHANICAL STRENGTH AND HEAT DISSIPATION (Solder Voids: Typical < 2%, Max. < 10% of Die Area)**
- **BUILT-IN STRESS RELIEF MECHANISM FOR SUPERIOR RELIABILITY AND PERFORMANCE**
- **SURGE OVERLOAD RATING TO 300 AMPS PEAK**
- **UL RECOGNIZED - FILE #E124962**

MECHANICAL DATA

- Case: Molded plastic, U/L Flammability Rating 94V-0
- Terminals: Round silver plated copper pins
- Soldering: Per MIL-STD 202 Method 208 guaranteed
- Polarity: Marked on side of case; positive lead at beveled corner
- Mounting Position: Any. Through hole provided for #6 screw
- Weight: 0.18 Ounces (5.4 Grams)

MECHANICAL SPECIFICATION

ACTUAL SIZE



SERIES DB1000-DB1010 and ADB1004-ADB1008

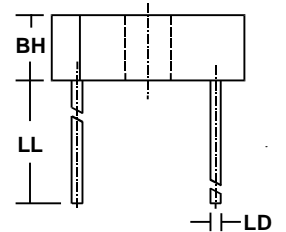
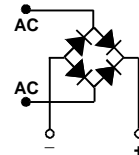
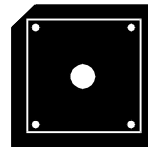

SYM	MILLIMETERS		INCHES	
	MIN	MAX	MIN	MAX
BL	18.5	19.6	0.73	0.77
BH	6.4	7.6	0.25	0.3
D1	12.2	13.2	0.48	0.52
LL	22.2	n/a	0.875	n/a
LD	1.2	1.3	0.048	0.052

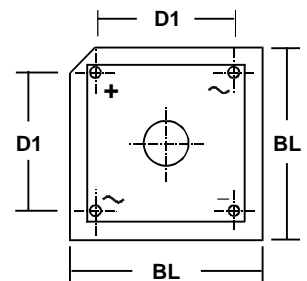

MAXIMUM RATINGS & ELECTRICAL CHARACTERISTICS

Ratings at 25°C ambient temperature unless otherwise specified.
 Single phase, half wave, 60Hz, resistive or inductive load.
 For capacitive loads, derate current by 20%.

PARAMETER (TEST CONDITIONS)	SYMBOL	RATINGS										UNITS	
		CONTROLLED AVALANCHE			NON-CONTROLLED AVALANCHE								
		ADB 1004	ADB 1006	ADB 1008	DB 1000	DB 1001	DB 1002	DB 1004	DB 1006	DB 1008	DB 1010		
Series Number													
Maximum DC Blocking Voltage	V _{RM}											VOLTS	
Working Peak Reverse Voltage	V _{RWM}	400	600	800	50	100	200	400	600	800	1000		
Maximum Peak Recurrent Reverse Voltage	V _{RRM}												
RMS Reverse Voltage	V _R (RMS)	280	420	560	35	70	140	280	420	560	700		
Power Dissipation in V _(BR) Region for 100 μS Square Wave	P _{RM}	500			n/a							WATTS	
Continuous Power Dissipation in V _(BR) Region @ T _{HS} =80° C (Heat Sink Temp)	P _R	2			n/a								
Thermal Energy (Rating for Fusing)	I ² t	64										AMPS ² SEC	
Peak Forward Surge Current. Single 60Hz Half-Sine Wave Superimposed on Rated Load (JEDEC Method). T _J = 150° C	I _{FSM}	300										AMPS	
Average Forward Rectified Current @ T _c = 50° C (Notes 1, 3) @ T _A = 50° C (Note 2)	I _o	10 8											
Junction Operating and Storage Temperature Range	T _J , T _{STG}	-55 to +150										°C	
Minimum Avalanche Voltage	V _{(BR) Min}	450	650	850	n/a							VOLTS	
Maximum Avalanche Voltage	V _{(BR) Max}	900	1100	1300	n/a								
Maximum Forward Voltage (Per Diode) at 5 Amps DC	V _{FM}	0.95 (Typ. 0.90)											
Maximum Reverse Current at Rated V _{RM} @ T _A = 25° C @ T _A = 100° C	I _{RM}	5 (Typical < 0.5 μA) 0.5										μA mA	
Minimum Insulation Breakdown Voltage (Circuit to Case)	V _{ISO}	2000										VOLTS	
Typical Thermal Resistance	Junction to Ambient (Note 2)	R _{θJA}	12										°C/W
	Junction to Case (Note 1)	R _{θJC}	5										

NOTES: (1) Bridge mounted on 5.1" x 4.3" x 0.11" thick (12.9cm x 10.8cm x 0.3cm) aluminum plate
 (2) Bridge mounted on PC Board with 0.5" sq. (12mm sq.) copper pads and bridge lead length of 0.375" (9.5mm)
 (3) Bolt bridge on heat sink with #6 screw, using silicon thermal compound between bridge and mounting surface for maximum heat transfer.

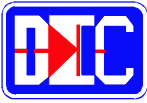

10 AMP SILICON BRIDGE RECTIFIERS

RATING & CHARACTERISTIC CURVES FOR SERIES DB1000 - DB1010 and SERIES ADB1004 - ADB1008

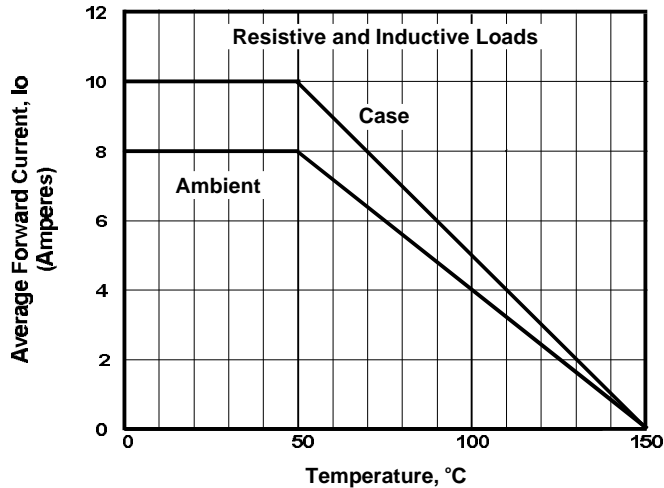

FIGURE 1. FORWARD CURRENT DERATING CURVE

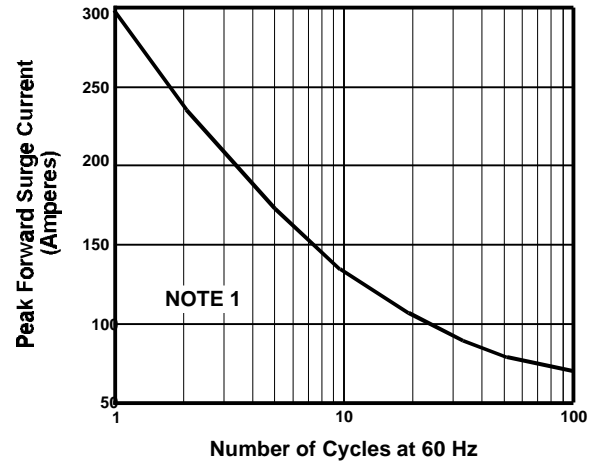

FIGURE 2. MAXIMUM NON-REPETITIVE SURGE CURRENT

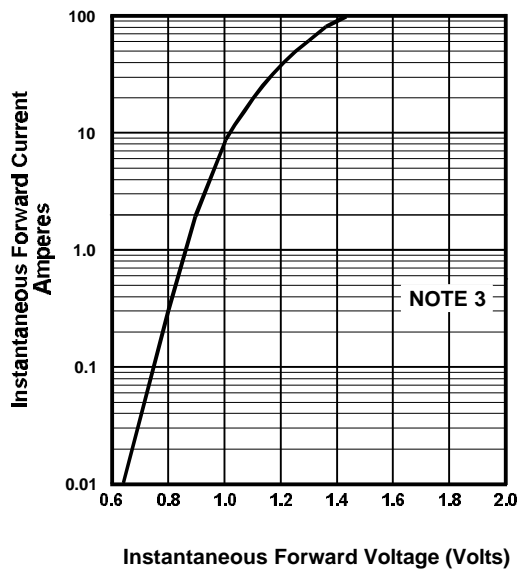

FIGURE 3. TYPICAL FORWARD CHARACTERISTIC PER DIODE

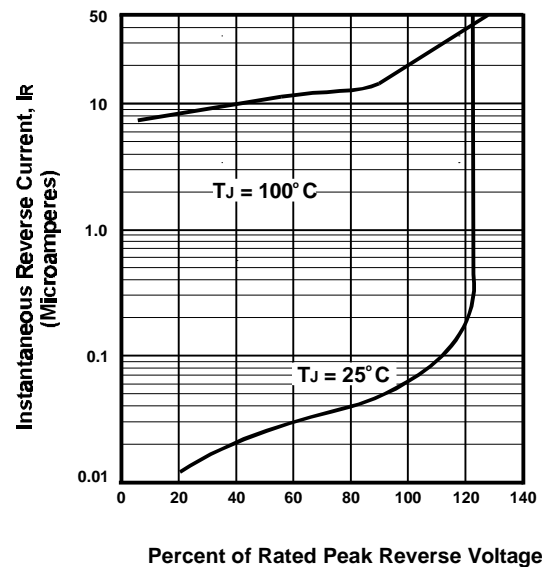

FIGURE 4. TYPICAL REVERSE CHARACTERISTICS

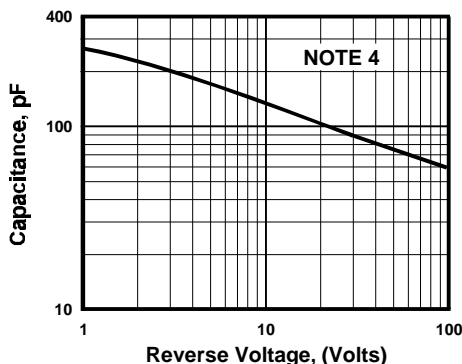

FIGURE 5. TYPICAL JUNCTION CAPACITANCE PER DIODE

NOTES

(1) Case Temperature, T_c , With Bridge Mounted on 5.1" x 4.3" x 0.11" Thick (12.9cm x 10.8cm x 0.3cm) Aluminum Plate

Ambient Temperature, T_a , With Bridge Mounted on PC Board With 0.5" Sq. (12mm Sq.) Copper Pads And Bridge Lead Length of 0.375" (9.5mm)

(2) $T_j = 150^\circ\text{C}$

(3) $T_j = 25^\circ\text{C}$; Pulse Width = 300 μSec ; 1% Duty Cycle

(4) $T_j = 25^\circ\text{C}$; $f = 1\text{ MHz}$; $V_{sig} = 50\text{mVp-p}$

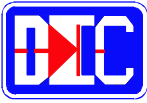

15 AMP SILICON BRIDGE RECTIFIERS

FEATURES

- VOID FREE VACUUM DIE SOLDERING FOR MAXIMUM MECHANICAL STRENGTH AND HEAT DISSIPATION (Solder Voids: Typical < 2%, Max. < 10% of Die Area)
- BUILT-IN STRESS RELIEF MECHANISM FOR SUPERIOR RELIABILITY AND PERFORMANCE
- ELECTRICALLY ISOLATED METAL CASE FOR MAXIMUM HEAT DISSIPATION
- **UL RECOGNIZED - FILE #E141956**

MECHANICAL DATA

- Case: Metal (Potting epoxy carries U/L flammability Rating 94V-0)
- Terminals: Round silver plated copper pins or fast-on terminals
- Soldering: Per MIL-STD 202 Method 208 guaranteed (Note 1)
- Polarity: Marked on side of case
- Mounting Position: Any. Through hole for #8 screw.
Max. mounting torque = 20 in-lb.
- Weight: Fast-on Terminals - 1.1 Ounces (31.6 Grams)
Wire Leads - 0.95 Ounce (28.5 Grams)

MECHANICAL SPECIFICATION

SERIES: DB1500 - DB1510 and ADB1504 - ADB1508

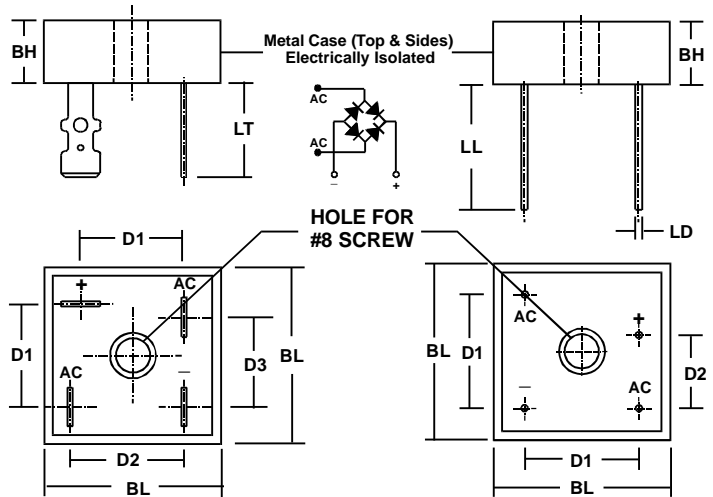

SYM	MILLIMETERS		INCHES	
	MIN	MAX	MIN	MAX
BL	28.4	28.7	1.12	1.13
BH	11.0	11.2	0.43	0.44
D1	15.7	16.7	0.62	0.66
D2	17.5	18.5	0.69	0.73
D3	13.5	14.5	0.53	0.57
LT	n/a	14.2	n/a	0.56

SYM	MILLIMETERS		INCHES	
	MIN	MAX	MIN	MAX
BL	28.4	28.7	1.12	1.13
BH	11.0	11.2	0.43	0.44
D1	17.5	18.5	0.69	0.73
D2	10.9	11.9	0.43	0.47
LL	20.6	n/a	0.81	n/a
LD	1.0	1.1	0.039	0.042

Suffix "T" indicates FAST-ON TERMINALS

Suffix "W" indicates WIRE LEADS

MAXIMUM RATINGS & ELECTRICAL CHARACTERISTICS

Ratings at 25 °C ambient temperature unless otherwise specified. Single phase, half wave, 60Hz, resistive or inductive load. For capacitive loads, derate current by 20%.

PARAMETER (TEST CONDITIONS)	SYMBOL	RATINGS										UNITS
		CONTROLLED AVALANCHE			NON-CONTROLLED AVALANCHE							
		ADB 1504	ADB 1506	ADB 1508	DB 1500	DB 1501	DB 1502	DB 1504	DB 1506	DB 1508	DB 1510	
Series Number												
Maximum DC Blocking Voltage	V _{RM}											
Working Peak Reverse Voltage	V _{RWM}	400	600	800	50	100	200	400	600	800	1000	VOLTS
Maximum Peak Recurrent Reverse Voltage	V _{RRM}											
RMS Reverse Voltage	V _{R (RMS)}	280	420	560	35	70	140	280	420	560	700	
Rating for Fusing (Non Repetitive; 1mS < t < 8.3mS)	I ² t	375										AMPS ² SEC
Peak Forward Surge Current. Single 60Hz Half-Sine Wave Superimposed on Rated Load (JEDEC Method). T _J = 150° C.	I _{FSM}	300										AMPS
Average Forward Rectified Current @ T _c = 50° C.	I _o	15										
Junction Operating and Storage Temperature Range	T _J , T _{STG}	-55 to +150										°C
Minimum Avalanche Voltage	V _{(BR) Min}	450	650	850	n/a							VOLTS
Maximum Avalanche Voltage	V _{(BR) Max}	900	1100	1300	n/a							
Maximum Forward Voltage (Per Diode) at 7.5 Amps DC	V _{FM}	1.03										
Maximum Reverse Current at Rated V _{RM} @ T _A = 25° C @ T _A = 125° C	I _{RM}	1 10										μA
Minimum Insulation Breakdown Voltage (Circuit to Case)	V _{ISO}	2000										VOLTS
Typical Thermal Resistance, Junction to Case	R _{θJC}	1.8										°C/W

3.01158mm

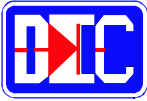

15 AMP SILICON BRIDGE RECTIFIERS

RATING & CHARACTERISTIC CURVES FOR SERIES DB1500 - DB1510 and SERIES ADB1504 - ADB1508

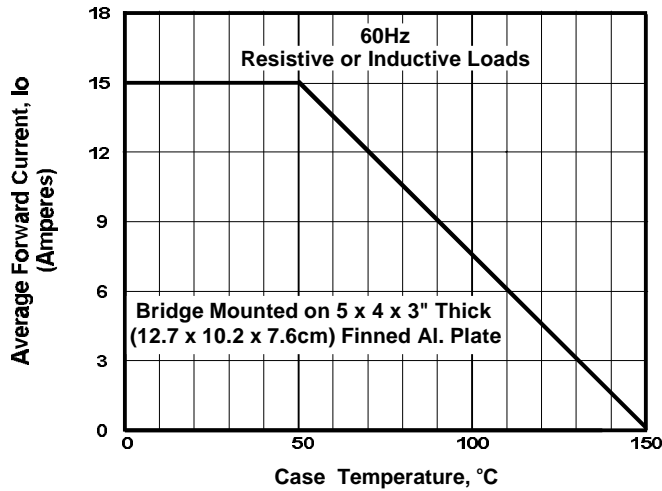

FIGURE 1. FORWARD CURRENT DERATING CURVE

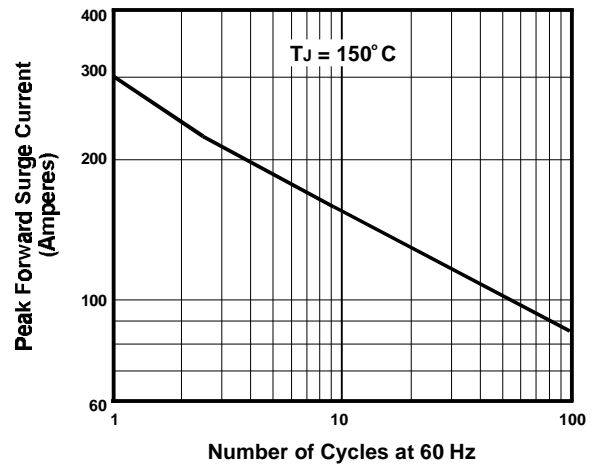

FIGURE 2. MAXIMUM NON-REPETITIVE SURGE CURRENT

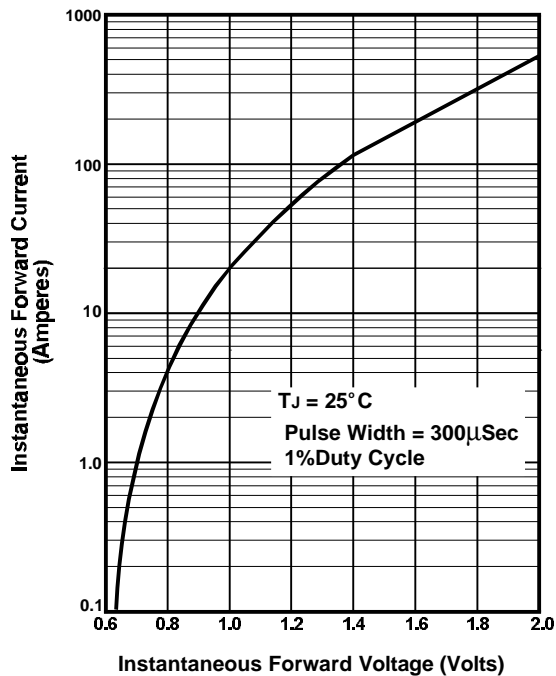

FIGURE 3. TYPICAL FORWARD CHARACTERISTIC PER DIODE

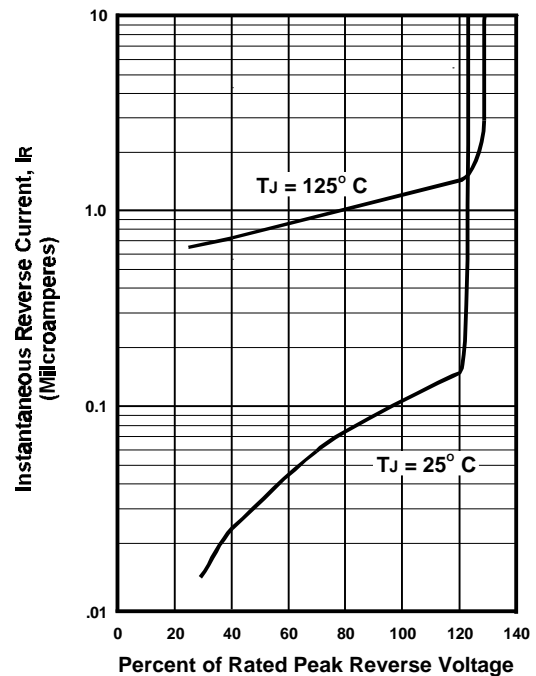
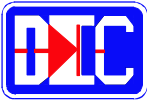

FIGURE 4. TYPICAL REVERSE CHARACTERISTICS



15 AMP SILICON BRIDGE RECTIFIERS

FEATURES

- VOID FREE VACUUM DIE SOLDERING FOR MAXIMUM MECHANICAL STRENGTH AND HEAT DISSIPATION (Solder Voids: Typical < 2%, Max. < 10% of Die Area)
- BUILT-IN STRESS RELIEF MECHANISM FOR SUPERIOR RELIABILITY AND PERFORMANCE
- INTEGRALLY MOLDED HEAT SINK PROVIDES VERY LOW THERMAL RESISTANCE FOR MAXIMUM HEAT DISSIPATION
- **UL RECOGNIZED - FILE #E141956**

MECHANICAL DATA

- Case: Molded plastic, U/L Flammability Rating 94V-0
- Terminals: Round silver plated copper pins or fast-on terminals
- Soldering: Per MIL-STD 202 Method 208 guaranteed (Note 1)
- Polarity: Marked on side of case
- Mounting Position: Any. Through hole for #8 screw.
Max. mounting torque = 20 in-lb.
- Weight: Fast-on Terminals - 0.7 Ounces (20.0 Grams)
Wire Leads - 0.55 Ounce (16.0 Grams)

MECHANICAL SPECIFICATION

SERIES: DB1500P - DB1510P and ADB1504P - ADB1508P

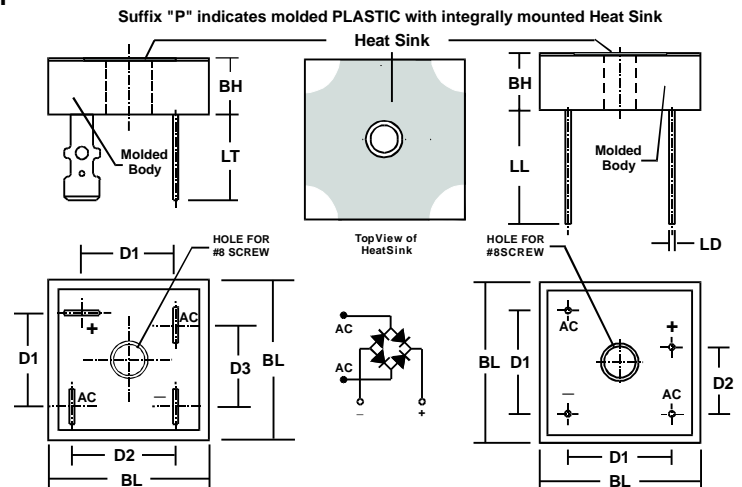

SYM	MILLIMETERS		INCHES	
	MIN	MAX	MIN	MAX
BL	28.4	28.7	1.12	1.13
BH	9.6	9.8	0.38	0.39
D1	15.7	16.7	0.62	0.66
D2	17.5	18.5	0.69	0.73
D3	13.5	14.5	0.53	0.57
LT	n/a	15.2	n/a	0.6

SYM	MILLIMETERS		INCHES	
	MIN	MAX	MIN	MAX
BL	28.4	28.7	1.12	1.13
BH	9.6	9.8	0.38	0.39
D1	17.5	18.5	0.69	0.73
D2	10.9	11.9	0.43	0.47
LL	20.6	n/a	0.81	n/a
LD	1.0	1.1	0.039	0.042

Suffix "T" indicates FAST-ON TERMINALS

Suffix "W" indicates WIRE LEADS

MAXIMUM RATINGS & ELECTRICAL CHARACTERISTICS

Ratings at 25 °C ambient temperature unless otherwise specified. Single phase, half wave, 60Hz, resistive or inductive load. For capacitive loads, derate current by 20%.

PARAMETER (TEST CONDITIONS)	SYMBOL	RATINGS										UNITS
		CONTROLLED AVALANCHE			NON-CONTROLLED AVALANCHE							
Series Number		ADB 1504P	ADB 1506P	ADB 1508P	DB 1500P	DB 1501P	DB 1502P	DB 1504P	DB 1506P	DB 1508P	DB 1510P	
Maximum DC Blocking Voltage	V _{RM}											VOLTS
Working Peak Reverse Voltage	V _{RWM}	400	600	800	50	100	200	400	600	800	1000	
Maximum Peak Recurrent Reverse Voltage	V _{RRM}											
RMS Reverse Voltage	V _{R (RMS)}	280	420	560	35	70	140	280	420	560	700	
Rating for Fusing (Non Repetitive; 1mS < t < 8.3mS)	I ² t	375										AMPS ² SEC
Peak Forward Surge Current. Single 60Hz Half-Sine Wave Superimposed on Rated Load (JEDEC Method). T _J = 150° C	I _{FSM}	300										AMPS
Average Forward Rectified Current @ T _c = 50° C	I _o	15										
Junction Operating and Storage Temperature Range	T _J , T _{STG}	-55 to +150										°C
Minimum Avalanche Voltage	V _{(BR) Min}	450	650	850	n/a							VOLTS
Maximum Avalanche Voltage	V _{(BR) Max}	900	1100	1300	n/a							
Maximum Forward Voltage (Per Diode) at 7.5 Amps DC	V _{FM}	1.03										
Maximum Reverse Current at Rated V _{RM} @ T _A = 25° C @ T _A = 125° C	I _{RM}	1 10										μA
Minimum Insulation Breakdown Voltage (Circuit to Case)	V _{ISO}	2500										VOLTS
Typical Thermal Resistance, Junction to Case	R _{θJC}	1.4										°C/W

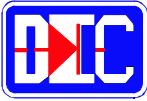

15 AMP SILICON BRIDGE RECTIFIERS

RATING & CHARACTERISTIC CURVES FOR SERIES DB1500P - DB1510P and SERIES ADB1504P - ADB1508P

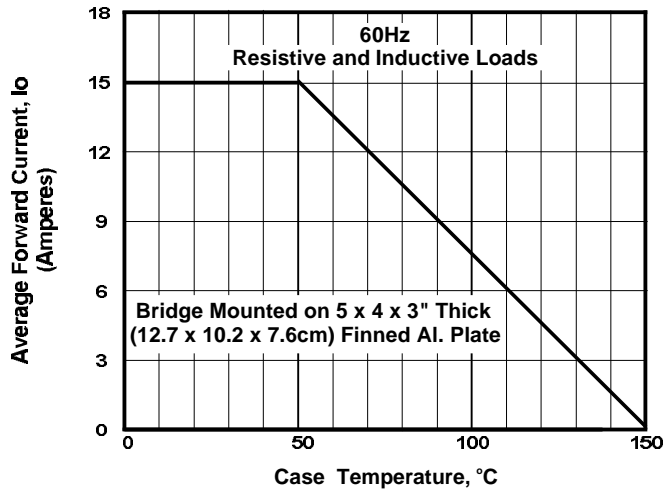

FIGURE 1. FORWARD CURRENT DERATING CURVE

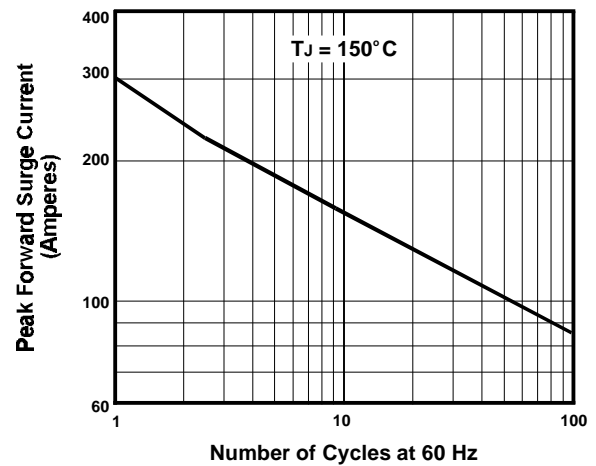

FIGURE 2. MAXIMUM NON-REPETITIVE SURGE CURRENT

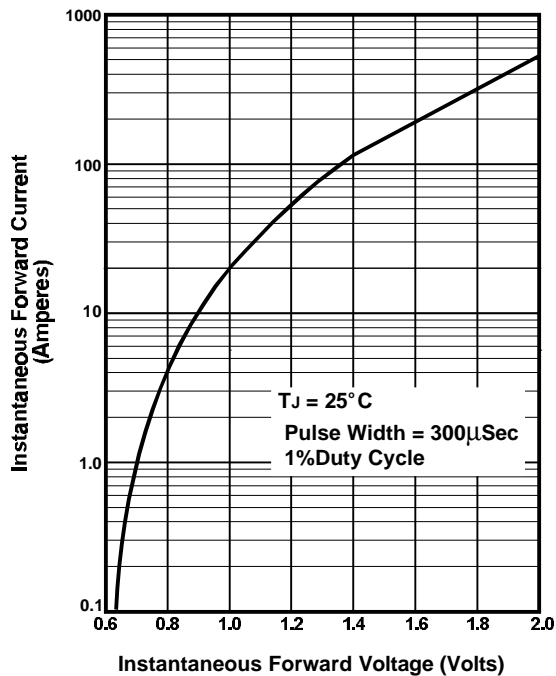

FIGURE 3. TYPICAL FORWARD CHARACTERISTIC PER DIODE

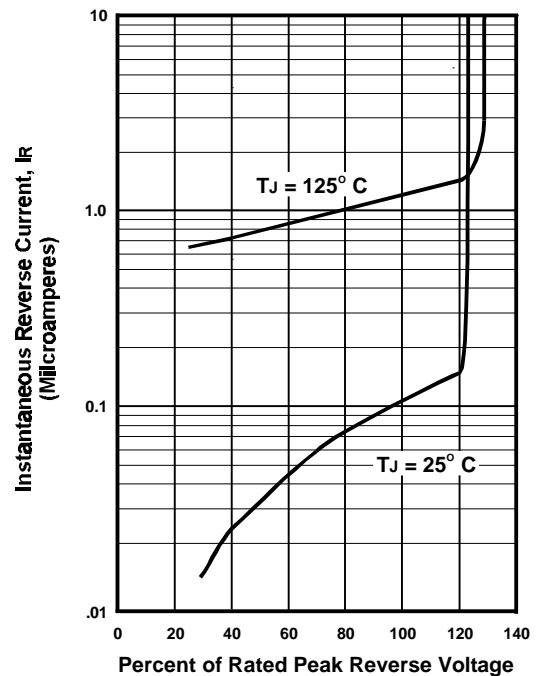
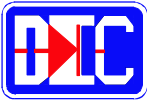

FIGURE 4. TYPICAL REVERSE CHARACTERISTICS



25 AMP SILICON BRIDGE RECTIFIERS

FEATURES

- VOID FREE VACUUM DIE SOLDERING FOR MAXIMUM MECHANICAL STRENGTH AND HEAT DISSIPATION (Solder Voids: Typical < 2%, Max. < 10% of Die Area)
- BUILT-IN STRESS RELIEF MECHANISM FOR SUPERIOR RELIABILITY AND PERFORMANCE
- ELECTRICALLY ISOLATED METAL CASE FOR MAXIMUM HEAT DISSIPATION
- **UL RECOGNIZED - FILE #E141956**

MECHANICAL DATA

- Case: Metal (Potting epoxy carries U/L flammability Rating 94V-0)
- Terminals: Round silver plated copper pins or fast-on terminals
- Soldering: Per MIL-STD 202 Method 208 guaranteed (Note 1)
- Polarity: Marked on side of case
- Mounting Position: Any. Through hole for #8 screw.
Max. mounting torque = 20 in-lb.
- Weight: Fast-on Terminals - 1.1 Ounces (31.6 Grams)
Wire Leads - 0.95 Ounce (28.5 Grams)

MECHANICAL SPECIFICATION

SERIES: DB2500 - DB2510 and ADB2504 - ADB2508

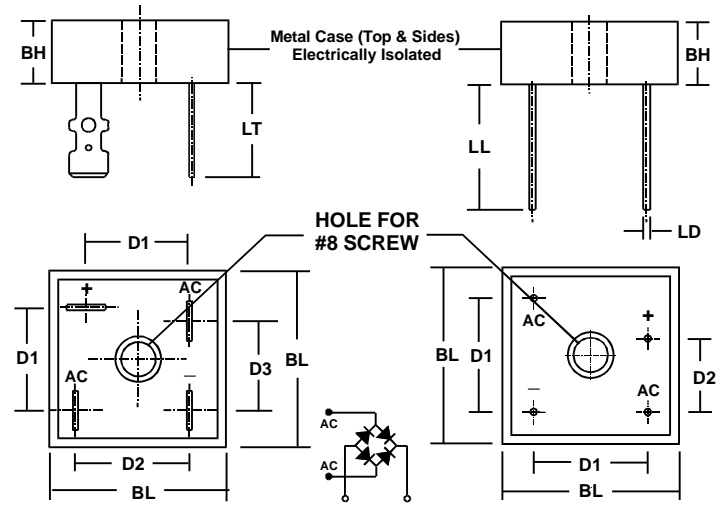

SYM	MILLIMETERS		INCHES	
	MIN	MAX	MIN	MAX
BL	28.4	28.7	1.12	1.13
BH	11.0	11.2	0.43	0.44
D1	15.7	16.7	0.62	0.66
D2	17.5	18.5	0.69	0.73
D3	13.5	14.5	0.53	0.57
LT	n/a	14.2	n/a	0.56

SYM	MILLIMETERS		INCHES	
	MIN	MAX	MIN	MAX
BL	28.4	28.7	1.12	1.13
BH	11.0	11.2	0.43	0.44
D1	17.5	18.5	0.69	0.73
D2	10.9	11.9	0.43	0.47
LL	20.6	n/a	0.81	n/a
LD	1.0	1.1	0.039	0.042

Suffix "T" indicates FAST-ON TERMINALS

Suffix "W" indicates WIRE LEADS

MAXIMUM RATINGS & ELECTRICAL CHARACTERISTICS

Ratings at 25 °C ambient temperature unless otherwise specified. Single phase, half wave, 60Hz, resistive or inductive load. For capacitive loads, derate current by 20%.

PARAMETER (TEST CONDITIONS)	SYMBOL	RATINGS										UNITS
		CONTROLLED AVALANCHE			NON-CONTROLLED AVALANCHE							
		ADB 2504	ADB 2506	ADB 2508	DB 2500	DB 2501	DB 2502	DB 2504	DB 2506	DB 2508	DB 2510	
Series Number												
Maximum DC Blocking Voltage	V _{RM}											
Working Peak Reverse Voltage	V _{RWM}	400	600	800	50	100	200	400	600	800	1000	VOLTS
Maximum Peak Recurrent Reverse Voltage	V _{RRM}											
RMS Reverse Voltage	V _{R (RMS)}	280	420	560	35	70	140	280	420	560	700	
Rating for Fusing (Non Repetitive; 1ms < t < 8.3ms)	I ² t	375										AMPS ² SEC
Peak Forward Surge Current. Single 60Hz Half-Sine Wave Superimposed on Rated Load (JEDEC Method). T _J = 150° C	I _{FSM}	300										AMPS
Average Forward Rectified Current @ T _c = 50° C	I _o	25										
Junction Operating and Storage Temperature Range	T _J , T _{STG}	-55 to +150										°C
Minimum Avalanche Voltage	V _{(BR) Min}	450	650	850	n/a							VOLTS
Maximum Avalanche Voltage	V _{(BR) Max}	900	1100	1300	n/a							
Maximum Forward Voltage (Per Diode) at 12.5 Amps DC	V _{FM}	1.03										
Maximum Reverse Current at Rated V _{RM} @ T _A = 25° C @ T _A = 125° C	I _{RM}	1 10										μA
Minimum Insulation Breakdown Voltage (Circuit to Case)	V _{ISO}	2000										VOLTS
Typical Thermal Resistance, Junction to Case	R _{θJC}	1.6										°C/W

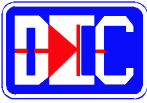

25 AMP SILICON BRIDGE RECTIFIERS

RATING & CHARACTERISTIC CURVES FOR SERIES DB2500 - DB2510 and SERIES ADB2504 - ADB2508

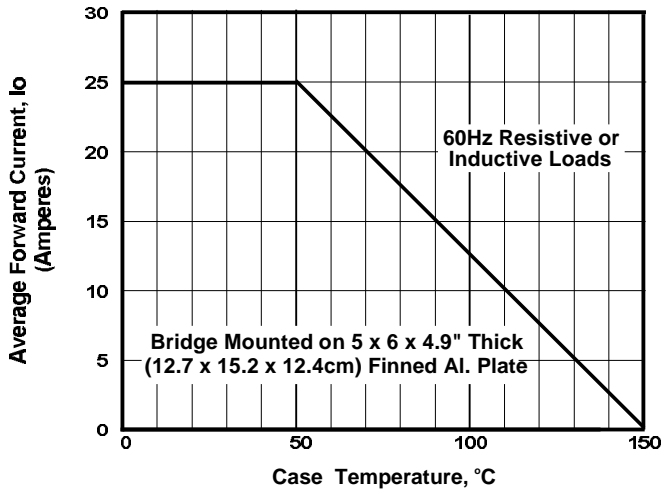

FIGURE 1. FORWARD CURRENT DERATING CURVE

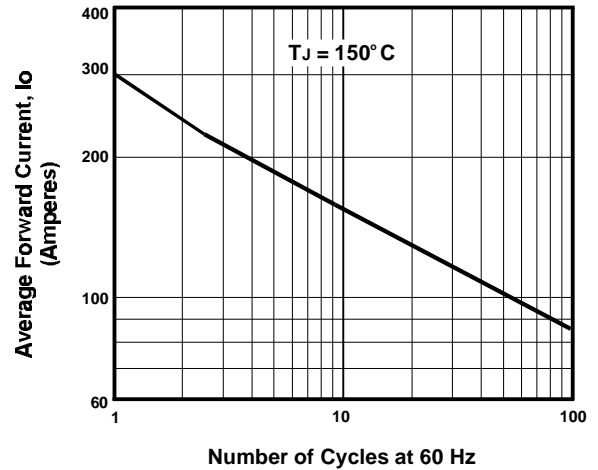

FIGURE 2. MAXIMUM NON-REPETITIVE SURGE CURRENT

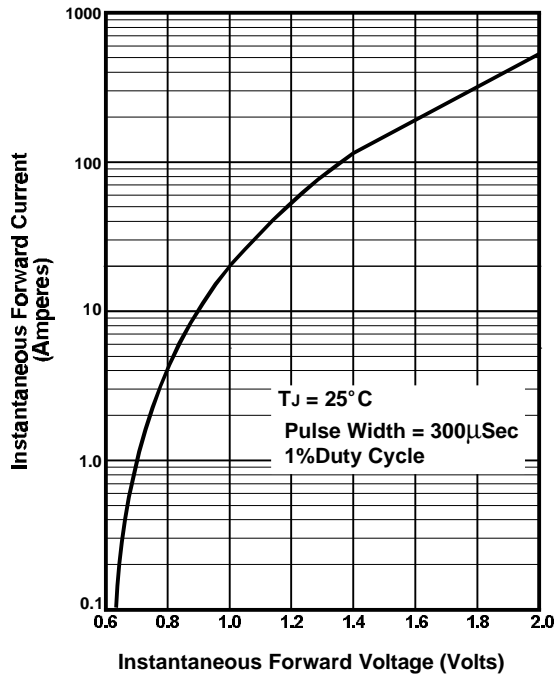

FIGURE 3. TYPICAL FORWARD CHARACTERISTIC PER DIODE

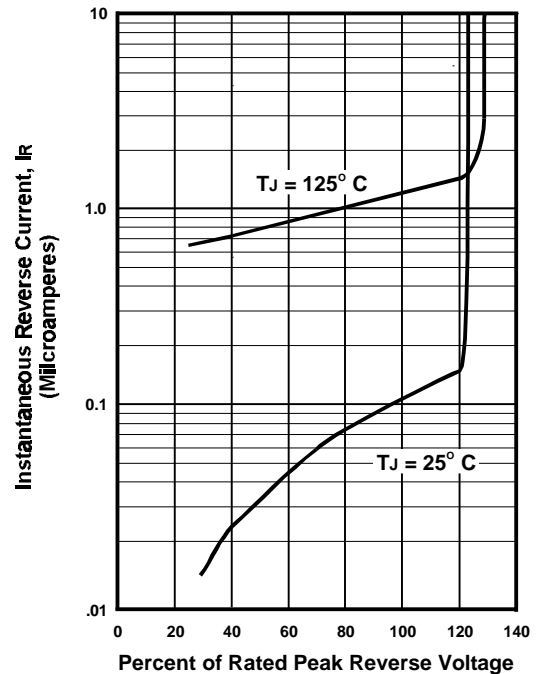
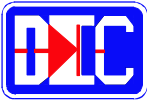

FIGURE 4. TYPICAL REVERSE CHARACTERISTICS



25 AMP SILICON BRIDGE RECTIFIERS

FEATURES

- **VOID FREE VACUUM DIE SOLDERING FOR MAXIMUM MECHANICAL STRENGTH AND HEAT DISSIPATION (Solder Voids: Typical < 2%, Max. < 10% of Die Area)**
- **BUILT-IN STRESS RELIEF MECHANISM FOR SUPERIOR RELIABILITY AND PERFORMANCE**
- **INTEGRALLY MOLDED HEAT SINK PROVIDES VERY LOW THERMAL RESISTANCE FOR MAXIMUM HEAT DISSIPATION**
- **UL RECOGNIZED - FILE #E141956**

MECHANICAL DATA

- **Case:** Molded plastic, U/L Flammability Rating 94V-0
- **Terminals:** Round silver plated copper pins or fast-on terminals
- **Soldering:** Per MIL-STD 202 Method 208 guaranteed (Note 1)
- **Polarity:** Marked on side of case
- **Mounting Position:** Any. Through hole for #8 screw.
Max. mounting torque = 20 in-lb.
- **Weight:** Fast-on Terminals - 0.7 Ounces (20.0 Grams)
Wire Leads - 0.55 Ounce (16.0 Grams)

MECHANICAL SPECIFICATION

SERIES: DB2500P - DB2510P and ADB2504P - ADB2508P

Suffix "P" indicates molded PLASTIC with integrally mounted Heat Sink

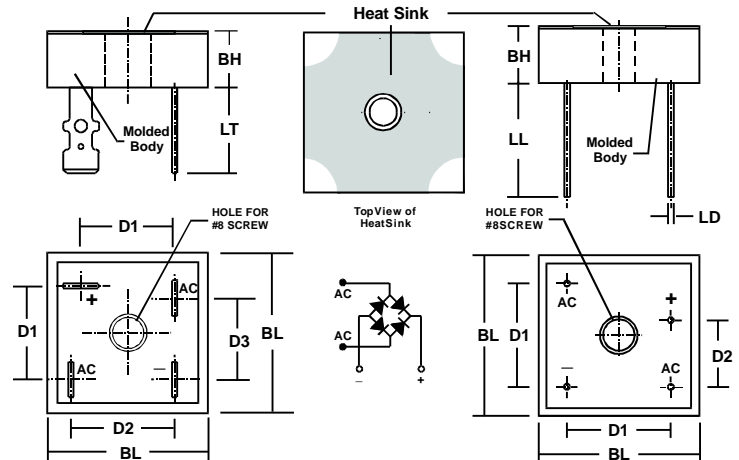

SYM	MILLIMETERS		INCHES	
	MIN	MAX	MIN	MAX
BL	28.4	28.7	1.12	1.13
BH	9.6	9.8	0.38	0.39
D1	15.7	16.7	0.62	0.66
D2	17.5	18.5	0.69	0.73
D3	13.5	14.5	0.53	0.57
LT	n/a	15.2	n/a	0.6

SYM	MILLIMETERS		INCHES	
	MIN	MAX	MIN	MAX
BL	28.4	28.7	1.12	1.13
BH	9.6	9.8	0.38	0.39
D1	17.5	18.5	0.69	0.73
D2	10.9	11.9	0.43	0.47
LL	20.6	n/a	0.81	n/a
LD	1.0	1.1	0.039	0.042

Suffix "T" indicates FAST-ON TERMINALS

Suffix "W" indicates WIRE LEADS

MAXIMUM RATINGS & ELECTRICAL CHARACTERISTICS

Ratings at 25 °C ambient temperature unless otherwise specified. Single phase, half wave, 60Hz, resistive or inductive load. For capacitive loads, derate current by 20%.

PARAMETER (TEST CONDITIONS)	SYMBOL	RATINGS									UNITS	
		CONTROLLED AVALANCHE			NON-CONTROLLED AVALANCHE							
Series Number		ADB 2504P	ADB 2506P	ADB 2508P	DB 2500P	DB 2501P	DB 2502P	DB 2504P	DB 2506P	DB 2508P	DB 2510P	
Maximum DC Blocking Voltage	V _{RM}											VOLTS
Working Peak Reverse Voltage	V _{RWM}	400	600	800	50	100	200	400	600	800	1000	
Maximum Peak Recurrent Reverse Voltage	V _{RRM}											
RMS Reverse Voltage	V _{R (RMS)}	280	420	560	35	70	140	280	420	560	700	
Rating for Fusing (Non Repetitive; 1mS < t < 8.3mS)	I ² t	373									AMPS ² SEC	
Peak Forward Surge Current. Single 60Hz Half-Sine Wave Superimposed on Rated Load (JEDEC Method). T _J = 150° C	I _{FSM}	300									AMPS	
Average Forward Rectified Current @ T _c = 50° C	I _o	25										
Junction Operating and Storage Temperature Range	T _J , T _{STG}	-55 to +150									°C	
Minimum Avalanche Voltage	V _{(BR) Min}	450	650	850	n/a						VOLTS	
Maximum Avalanche Voltage	V _{(BR) Max}	900	1100	1300	n/a							
Maximum Forward Voltage (Per Diode) at 12.5 Amps DC	V _{FM}	1.03										
Maximum Reverse Current at Rated V _{RM} @ T _A = 25° C @ T _A = 125° C	I _{RM}	1 10									μA	
Minimum Insulation Breakdown Voltage (Circuit to Case)	V _{ISO}	2500									VOLTS	
Typical Thermal Resistance, Junction to Case	R _{θJC}	1.2									°C/W	

3.0125dbp

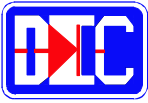

25 AMP SILICON BRIDGE RECTIFIERS

RATING & CHARACTERISTIC CURVES FOR SERIES DB2500P - DB2510P and SERIES ADB2504P - ADB2508P

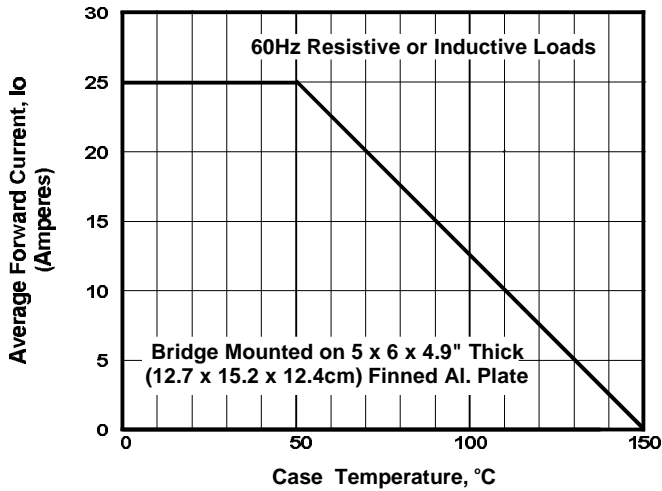

FIGURE 1. FORWARD CURRENT DERATING CURVE

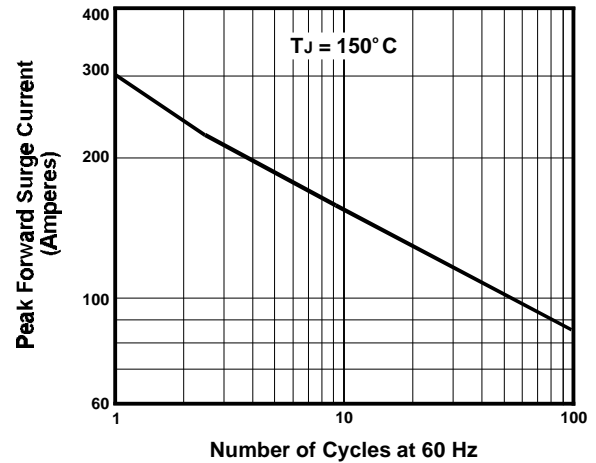

FIGURE 2. MAXIMUM NON-REPETITIVE SURGE CURRENT

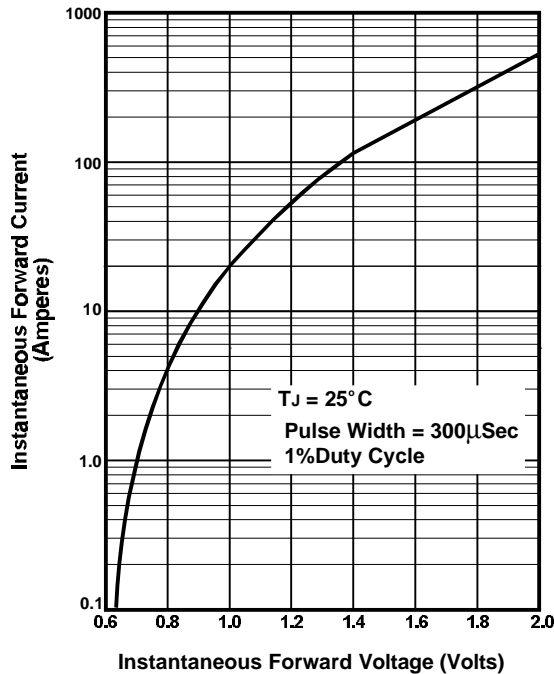

FIGURE 3. TYPICAL FORWARD CHARACTERISTIC PER DIODE

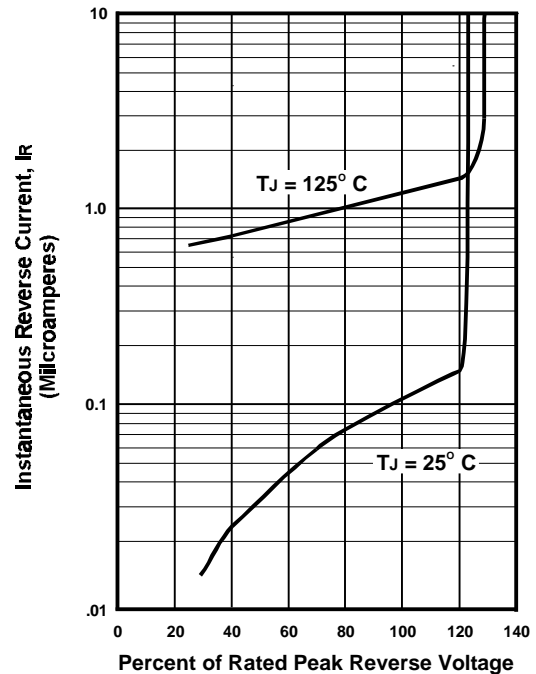
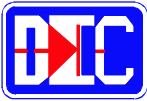

FIGURE 4. TYPICAL REVERSE CHARACTERISTICS



35 AMP SILICON BRIDGE RECTIFIERS

FEATURES

- **VOID FREE VACUUM DIE SOLDERING FOR MAXIMUM MECHANICAL STRENGTH AND HEAT DISSIPATION (Solder Voids: Typical < 2%, Max. < 10% of Die Area)**
- **BUILT-IN STRESS RELIEF MECHANISM FOR SUPERIOR RELIABILITY AND PERFORMANCE**
- **ELECTRICALLY ISOLATED METAL CASE FOR MAXIMUM HEAT DISSIPATION**
- **UL RECOGNIZED - FILE #E141956**

MECHANICAL DATA

- **Case:** Metal (Potting epoxy carries U/L flammability Rating 94V-0)
- **Terminals:** Round silver plated copper pins or fast-on terminals
- **Soldering:** Per MIL-STD 202 Method 208 guaranteed (Note 1)
- **Polarity:** Marked on side of case
- **Mounting Position:** Any. Through hole for #8 screw.
Max. mounting torque = 20 in-lb.
- **Weight:** Fast-on Terminals - 1.1 Ounces (31.6 Grams)
Wire Leads - 0.95 Ounce (28.5 Grams)

MECHANICAL SPECIFICATION

SERIES: DB3500 - DB3510 and ADB3504 - ADB3508

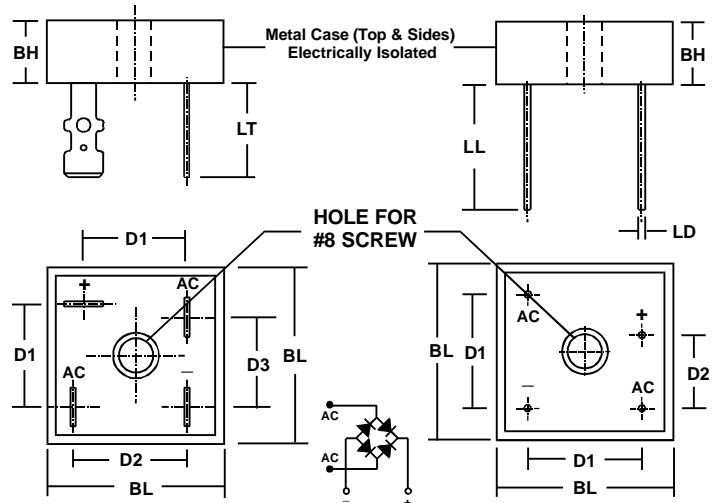

SYM	MILLIMETERS		INCHES	
	MIN	MAX	MIN	MAX
BL	28.4	28.7	1.12	1.13
BH	11.0	11.2	0.43	0.44
D1	15.7	16.7	0.62	0.66
D2	17.5	18.5	0.69	0.73
D3	13.5	14.5	0.53	0.57
LT	n/a	14.2	n/a	0.56

SYM	MILLIMETERS		INCHES	
	MIN	MAX	MIN	MAX
BL	28.4	28.7	1.12	1.13
BH	11.0	11.2	0.43	0.44
D1	17.5	18.5	0.69	0.73
D2	10.9	11.9	0.43	0.47
LL	20.6	n/a	0.81	n/a
LD	1.0	1.1	0.039	0.042

Suffix "T" indicates FAST-ON TERMINALS

Suffix "W" indicates WIRE LEADS

MAXIMUM RATINGS & ELECTRICAL CHARACTERISTICS

Ratings at 25 °C ambient temperature unless otherwise specified. Single phase, half wave, 60Hz, resistive or inductive load. For capacitive loads, derate current by 20%.

PARAMETER (TEST CONDITIONS)	SYMBOL	RATINGS										UNITS
		CONTROLLED AVALANCHE			NON-CONTROLLED AVALANCHE							
		ADB 3504	ADB 3506	ADB 3508	DB 3500	DB 3501	DB 3502	DB 3504	DB 3506	DB 3508	DB 3510	
Series Number												
Maximum DC Blocking Voltage	V _{RM}											
Working Peak Reverse Voltage	V _{RWM}	400	600	800	50	100	200	400	600	800	1000	VOLTS
Maximum Peak Recurrent Reverse Voltage	V _{RRM}											
RMS Reverse Voltage	V _{R (RMS)}	280	420	560	35	70	140	280	420	560	700	
Rating for Fusing (Non Repetitive; 1mS < t < 8.3mS)	I ² t	664										AMPS ² SEC
Peak Forward Surge Current. Single 60Hz Half-Sine Wave Superimposed on Rated Load (JEDEC Method). T _J = 150° C	I _{FSM}	400										AMPS
Average Forward Rectified Current @ T _c = 50° C	I _o	35										
Junction Operating and Storage Temperature Range	T _J , T _{STG}	-55 to +150										°C
Minimum Avalanche Voltage	V _{(BR) Min}	450	650	850	n/a							VOLTS
Maximum Avalanche Voltage	V _{(BR) Max}	900	1100	1300	n/a							
Maximum Forward Voltage (Per Diode) at 17.5 Amps DC	V _{FM}	1.03										
Maximum Reverse Current at Rated V _{RM} @ T _A = 25° C @ T _A = 125° C	I _{RM}	1 10										μA
Minimum Insulation Breakdown Voltage (Circuit to Case)	V _{ISO}	2000										VOLTS
Typical Thermal Resistance, Junction to Case	R _{θJC}	1.6										°C/W

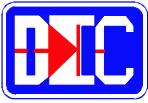

35 AMP SILICON BRIDGE RECTIFIERS

RATING & CHARACTERISTIC CURVES FOR SERIES DB3500 - DB3510 and SERIES ADB3504 - ADB3508

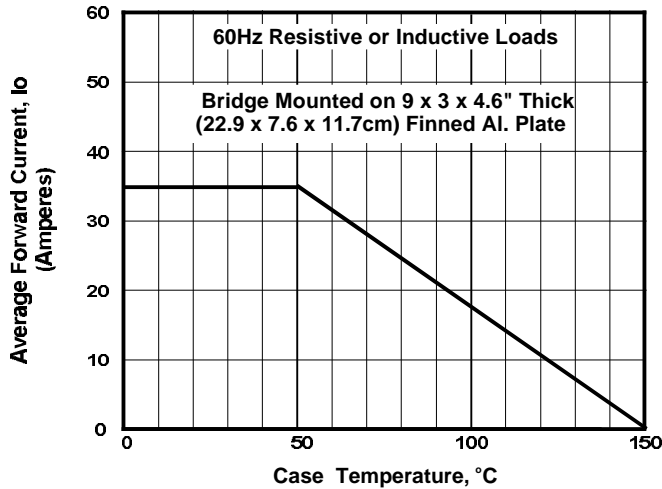

FIGURE 1. FORWARD CURRENT DERATING CURVE

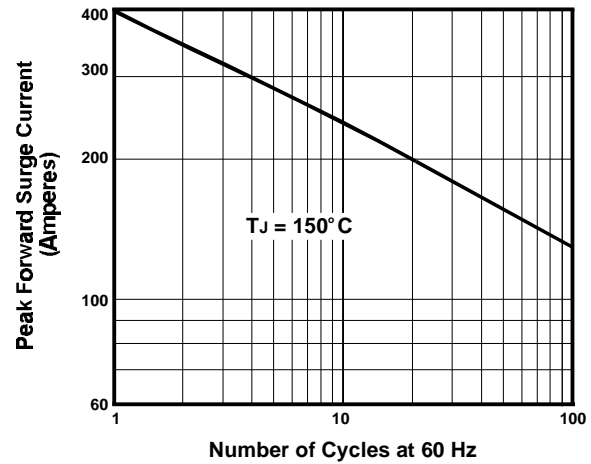

FIGURE 2. MAXIMUM NON-REPETITIVE SURGE CURRENT

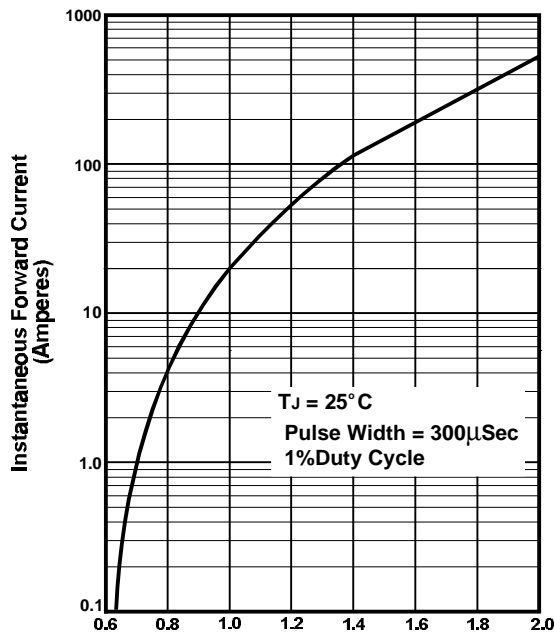

FIGURE 3. TYPICAL FORWARD CHARACTERISTICS PER DIODE

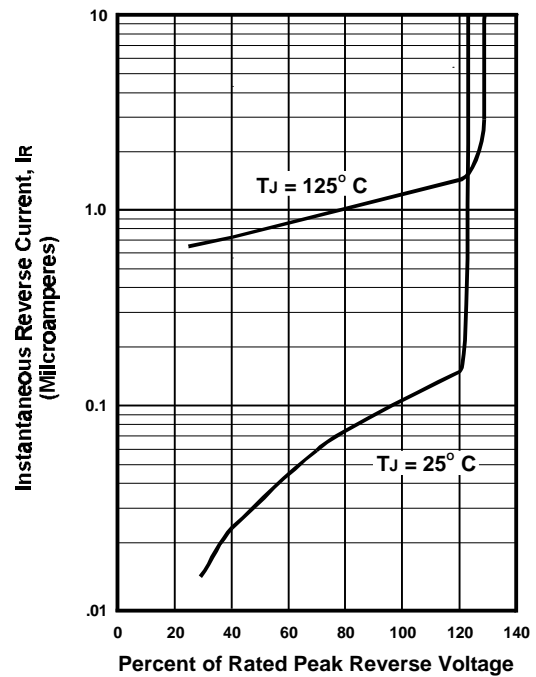
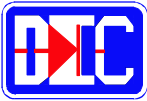

FIGURE 4. TYPICAL REVERSE CHARACTERISTICS



35 AMP SILICON BRIDGE RECTIFIERS

FEATURES

- **VOID FREE VACUUM DIE SOLDERING FOR MAXIMUM MECHANICAL STRENGTH AND HEAT DISSIPATION (Solder Voids: Typical < 2%, Max. < 10% of Die Area)**
- **BUILT-IN STRESS RELIEF MECHANISM FOR SUPERIOR RELIABILITY AND PERFORMANCE**
- **INTEGRALLY MOLDED HEAT SINK PROVIDES VERY LOW THERMAL RESISTANCE FOR MAXIMUM HEAT DISSIPATION**
- **UL RECOGNIZED - FILE #E141956**

MECHANICAL DATA

- **Case:** Molded plastic, U/L Flammability Rating 94V-0
- **Terminals:** Round silver plated copper pins or fast-on terminals
- **Soldering:** Per MIL-STD 202 Method 208 guaranteed
- **Polarity:** Marked on side of case
- **Mounting Position:** Any. Through hole for #8 screw.
Max. mounting torque = 20 in-lb.
- **Weight:** Fast-on Terminals - 0.7 Ounces (20.0 Grams)
Wire Leads - 0.55 Ounces (16.0 Grams)

MECHANICAL SPECIFICATION

SERIES: DB3500P - DB3510P and ADB3504P - ADB3508P

Suffix "P" indicates molded PLASTIC with integrally mounted Heat Sink

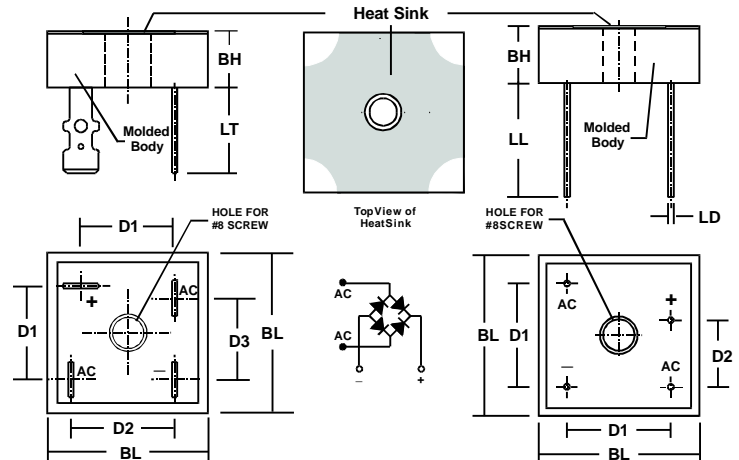

SYM	MILLIMETERS		INCHES	
	MIN	MAX	MIN	MAX
BL	28.4	28.7	1.12	1.13
BH	9.6	9.8	0.38	0.39
D1	15.7	16.7	0.62	0.66
D2	17.5	18.5	0.69	0.73
D3	13.5	14.5	0.53	0.57
LT	n/a	15.2	n/a	0.6

SYM	MILLIMETERS		INCHES	
	MIN	MAX	MIN	MAX
BL	28.4	28.7	1.12	1.13
BH	9.6	9.8	0.38	0.39
D1	17.5	18.5	0.69	0.73
D2	10.9	11.9	0.43	0.47
LL	20.6	n/a	0.81	n/a
LD	1.0	1.1	0.039	0.042

Suffix "T" indicates FAST-ON TERMINALS

Suffix "W" indicates WIRE LEADS

MAXIMUM RATINGS & ELECTRICAL CHARACTERISTICS

Ratings at 25 °C ambient temperature unless otherwise specified. Single phase, half wave, 60Hz, resistive or inductive load. For capacitive loads, derate current by 20%.

PARAMETER (TEST CONDITIONS)	SYMBOL	RATINGS										UNITS
		CONTROLLED AVALANCHE			NON-CONTROLLED AVALANCHE							
		ADB 3504P	ADB 3506P	ADB 3508P	DB 3500P	DB 3501P	DB 3502P	DB 3504P	DB 3506P	DB 3508P	DB 3510P	
Series Number												
Maximum DC Blocking Voltage	V _{RM}											VOLTS
Working Peak Reverse Voltage	V _{RWM}	400	600	800	50	100	200	400	600	800	1000	
Maximum Peak Recurrent Reverse Voltage	V _{RRM}											
RMS Reverse Voltage	V _{R (RMS)}	280	420	560	35	70	140	280	420	560	700	
Rating for Fusing (Non Repetitive; 1mS < t < 8.3mS)	I ² t	664										AMPS ² SEC
Peak Forward Surge Current. Single 60Hz Half-Sine Wave Superimposed on Rated Load (JEDEC Method). T _J = 150° C	I _{FSM}	400										AMPS
Average Forward Rectified Current @ T _c = 50° C	I _o	35										
Junction Operating and Storage Temperature Range	T _J , T _{STG}	-55 to +150										°C
Minimum Avalanche Voltage	V _{(BR) Min}	450	650	850	n/a							VOLTS
Maximum Avalanche Voltage	V _{(BR) Max}	900	1100	1300	n/a							
Maximum Forward Voltage (Per Diode) at 17.5 Amps DC	V _{FM}	1.03										
Maximum Reverse Current at Rated V _{RM} @ T _A = 25° C @ T _A = 125° C	I _{RM}	1 10										μA
Minimum Insulation Breakdown Voltage (Circuit to Case)	V _{ISO}	2500										VOLTS
Typical Thermal Resistance, Junction to Case	R _{θJC}	1.2										°C/W

3.0135dbp

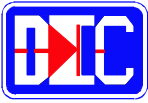

35 AMP SILICON BRIDGE RECTIFIERS

RATING & CHARACTERISTIC CURVES FOR SERIES DB3500P - DB3510P and SERIES ADB3504P - ADB3508P

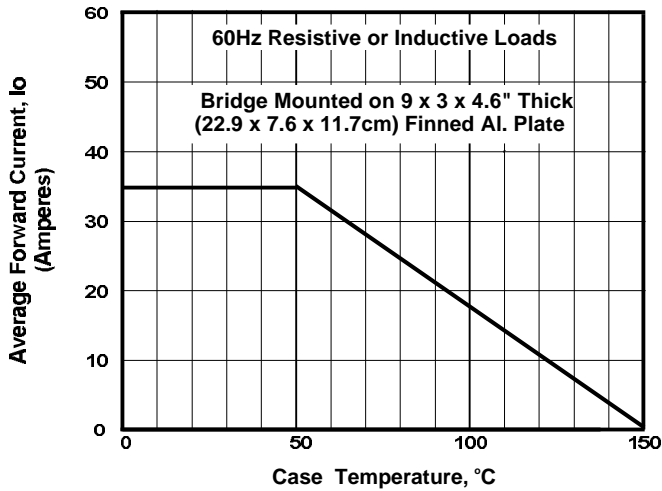

FIGURE 1. FORWARD CURRENT DERATING CURVE

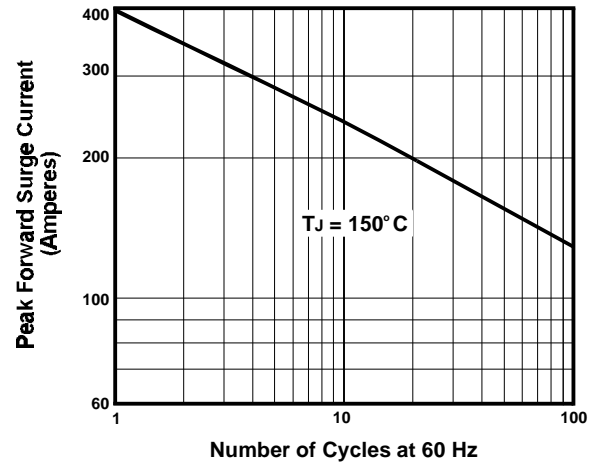

FIGURE 2. MAXIMUM NON-REPETITIVE SURGE CURRENT

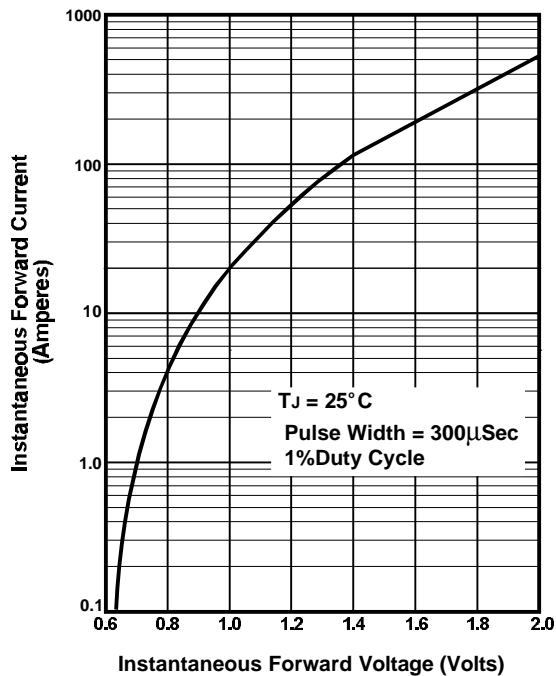

FIGURE 3. TYPICAL FORWARD CHARACTERISTIC PER DIODE

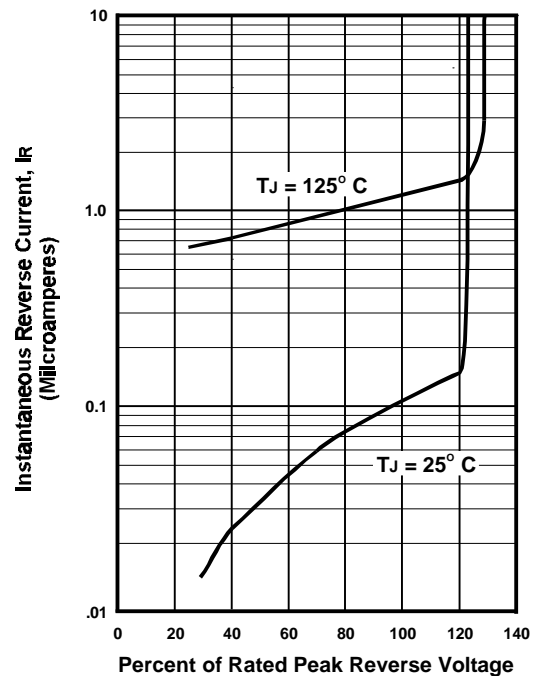
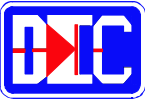

FIGURE 4. TYPICAL REVERSE CHARACTERISTICS



40 AMP SILICON BRIDGE RECTIFIERS

FEATURES

- VOID FREE VACUUM DIE SOLDERING FOR MAXIMUM MECHANICAL STRENGTH AND HEAT DISSIPATION (Solder Voids: Typical < 2%, Max. < 10% of Die Area)
- BUILT-IN STRESS RELIEF MECHANISM FOR SUPERIOR RELIABILITY AND PERFORMANCE
- INTEGRALLY MOLDED HEAT SINK PROVIDES VERY LOW THERMAL RESISTANCE FOR MAXIMUM HEAT TRANSFER
- SPACE SAVING IN-LINE DESIGN FOR PRINTED CIRCUIT BOARD APPLICATIONS

UL RECOGNIZED - FILE #E124962

MECHANICAL DATA

- Case: Molded plastic, U/L Flammability Rating 94V-0
- Terminals: Round silver plated pins
- Soldering: Per MIL-STD 202 Method 208 guaranteed
- Polarity: Marked on case
- Mounting Position: Any. Bolt down on heatsink
Maximum mounting torque = 20 in. lb.
- Weight: 0.6 Ounces (17 Grams)

MECHANICAL SPECIFICATION

SDB PACKAGE SHOWN ACTUAL SIZE

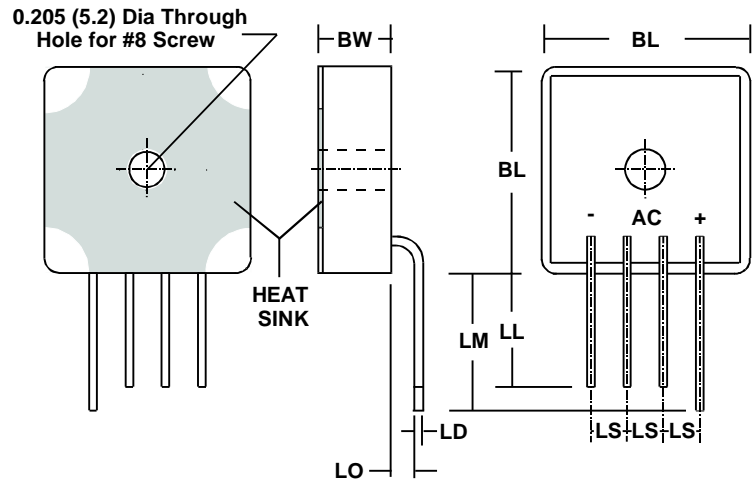

SYM	MILLIMETERS		INCHES	
	MIN	MAX	MIN	MAX
BL	28.4	28.7	1.12	1.13
BW	n/a	10.3	n/a	0.405
LD	1.27 Typ		0.050 Typ	
LL	15.9	n/a	0.625	n/a
LM	19.0	n/a	0.750	n/a
LO	3.175 Nom		0.125 Nom	
LS	5.08 Typ		0.200 Typ	

MAXIMUM RATINGS & ELECTRICAL CHARACTERISTICS

Ratings at 25 °C ambient temperature unless otherwise specified.
 Single phase, half wave, 60Hz, resistive or inductive load.
 For capacitive loads, derate current by 20%.

PARAMETER (TEST CONDITIONS)	SYMBOL	RATINGS							UNITS
		SDB 4000	SDB 4001	SDB 4002	SDB 4004	SDB 4006	SDB 4008	SDB 4010	
Series Number									
Maximum DC Blocking Voltage	V _{RM}	50	100	200	400	600	800	1000	VOLTS
Maximum RMS Voltage	V _{RM} S	35	70	140	280	420	560	700	
Maximum Peak Recurrent Reverse Voltage	V _{RRM}	50	100	200	400	600	800	1000	
Average Forward Rectified Current @ T _c = 55 °C	I _o	40							AMPS
Peak Forward Surge Current. Single 60Hz Half-Sine Wave Superimposed on Rated Load (JEDEC Method). T _J = 175° C	I _{FSM}	500							
Forward Voltage (Per Diode) at 20 Amps DC Max. Typ.	V _{FM}	0.96 0.93					1.00 0.97		VOLTS
Maximum Average DC Reverse Current At Rated DC Blocking Voltage @ T _A = 25° C @ T _A = 125° C	I _{RM}	2 20							μA
Minimum Insulation Breakdown Voltage (Circuit to Case)	V _{ISO}	2500							VOLTS
Typical Thermal Resistance, Junction to Case	R _{θJC}	1.1							°C/W
Junction Operating and Storage Temperature Range	T _J , T _{STG}	-55 to +175							°C

3.01 40sdb

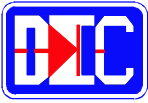

40 AMP SILICON BRIDGE RECTIFIERS

RATING & CHARACTERISTIC CURVES FOR SDB4000-4010 SERIES

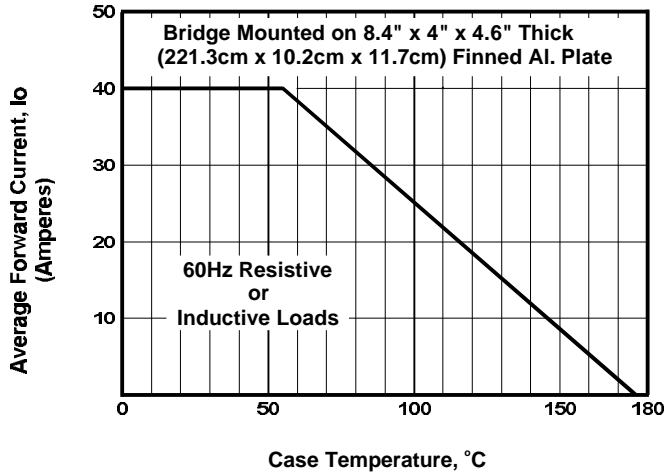

FIGURE 1. FORWARD CURRENT DERATING CURVE

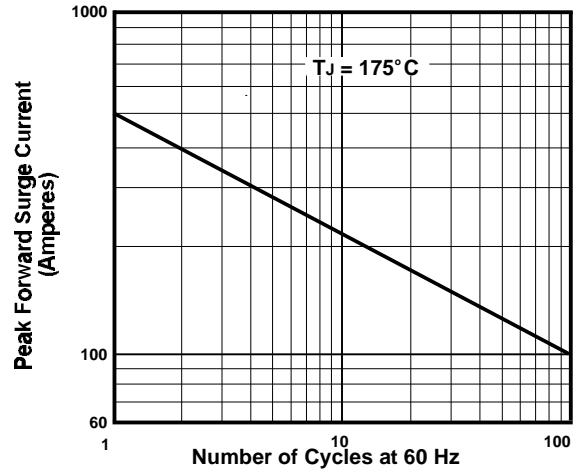

FIGURE 2. MAXIMUM NON-REPETITIVE SURGE CURRENT

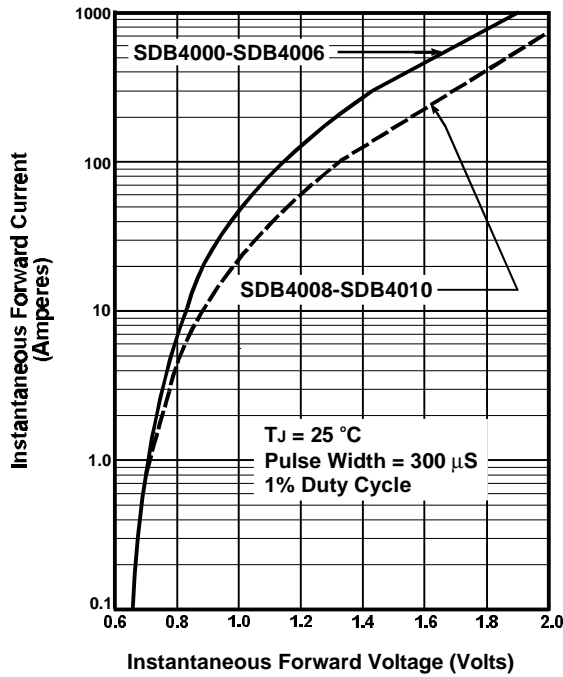

FIGURE 3. TYPICAL FORWARD CHARACTERISTIC PER DIODE

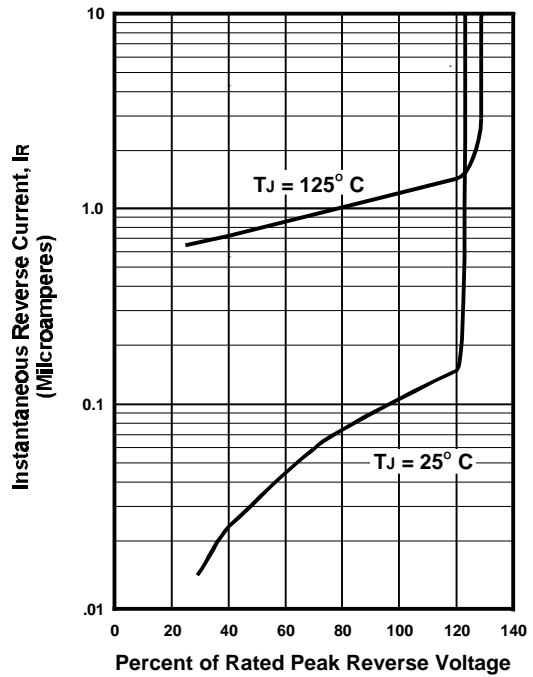
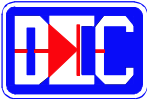

FIGURE 4. TYPICAL REVERSE CHARACTERISTICS



50 AMP SILICON BRIDGE RECTIFIERS

FEATURES

- VOID FREE VACUUM DIE SOLDERING FOR MAXIMUM MECHANICAL STRENGTH AND HEAT DISSIPATION (Solder Voids: Typical < 2%, Max. < 10% of Die Area)
- BUILT-IN STRESS RELIEF MECHANISM FOR SUPERIOR RELIABILITY AND PERFORMANCE
- INTEGRALLY MOLDED HEAT SINK PROVIDES VERY LOW THERMAL RESISTANCE FOR MAXIMUM HEAT TRANSFER
- SPACE SAVING IN-LINE DESIGN FOR PRINTED CIRCUIT BOARD APPLICATIONS

UL RECOGNIZED - FILE #E124962

MECHANICAL DATA

- Case: Molded plastic, U/L Flammability Rating 94V-0
- Terminals: Round silver plated pins
- Soldering: Per MIL-STD 202 Method 208 guaranteed
- Polarity: Marked on case
- Mounting Position: Any. Bolt down on heatsink
Maximum mounting torque = 20 in. lb.
- Weight: 0.6 Ounces (17 Grams)

MECHANICAL SPECIFICATION

SDB PACKAGE SHOWN ACTUAL SIZE

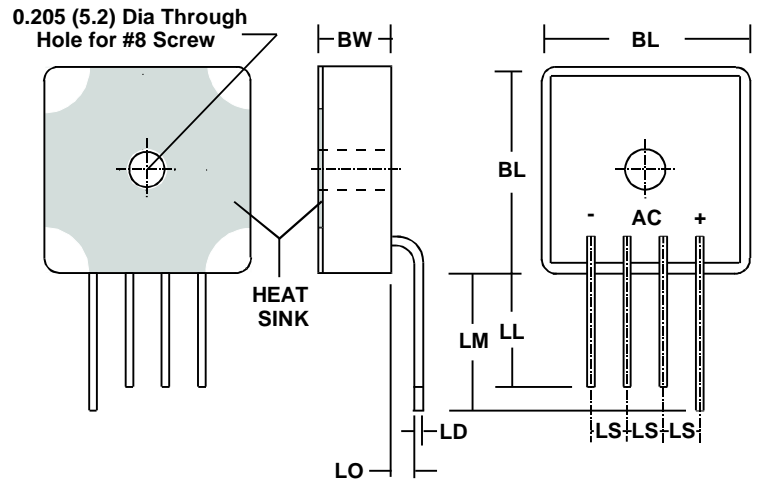

SYM	MILLIMETERS		INCHES	
	MIN	MAX	MIN	MAX
BL	28.4	28.7	1.12	1.13
BW	n/a	10.3	n/a	0.405
LD	1.27 Typ		0.050 Typ	
LL	15.9	n/a	0.625	n/a
LM	19.0	n/a	0.750	n/a
LO	3.175 Nom		0.125 Nom	
LS	5.08 Typ		0.200 Typ	

MAXIMUM RATINGS & ELECTRICAL CHARACTERISTICS

Ratings at 25 °C ambient temperature unless otherwise specified.
 Single phase, half wave, 60Hz, resistive or inductive load.
 For capacitive loads, derate current by 20%.

PARAMETER (TEST CONDITIONS)	SYMBOL	RATINGS								UNITS
		SDB 5000	SDB 5001	SDB 5002	SDB 5004	SDB 5006	SDB 5008	SDB 5010		
Series Number										
Maximum DC Blocking Voltage	V _{RM}	50	100	200	400	600	800	1000		VOLTS
Maximum RMS Voltage	V _{RM} S	35	70	140	280	420	560	700		
Maximum Peak Recurrent Reverse Voltage	V _{RRM}	50	100	200	400	600	800	1000		
Average Forward Rectified Current @ T _c = 55° C	I _o	50								AMPS
Peak Forward Surge Current. Single 60Hz Half-Sine Wave Superimposed on Rated Load (JEDEC Method). T _J = 175° C	I _{FSM}	600								
Forward Voltage (Per Diode) at 20 Amps DC Max. Typ.	V _{FM}	0.96 0.93				1.00 0.97				VOLTS
Maximum Average DC Reverse Current At Rated DC Blocking Voltage @ T _A = 25° C @ T _A = 125° C	I _{RM}	2 20								μA
Minimum Insulation Breakdown Voltage (Circuit to Case)	V _{ISO}	2500								VOLTS
Typical Thermal Resistance, Junction to Case	R _{θJC}	1.10								°C/W
Junction Operating and Storage Temperature Range	T _J , T _{STG}	-55 to +175								°C

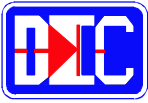

50 AMP SILICON BRIDGE RECTIFIERS

RATING & CHARACTERISTIC CURVES FOR SERIES SDB5000 - SDB5010

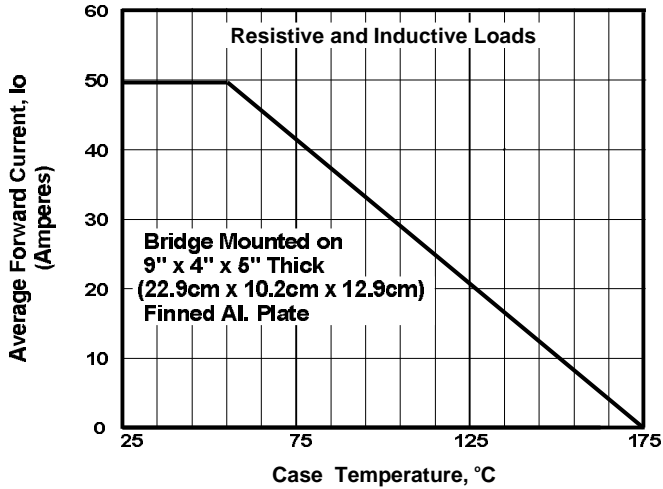

FIGURE 1. FORWARD CURRENT DERATING CURVE

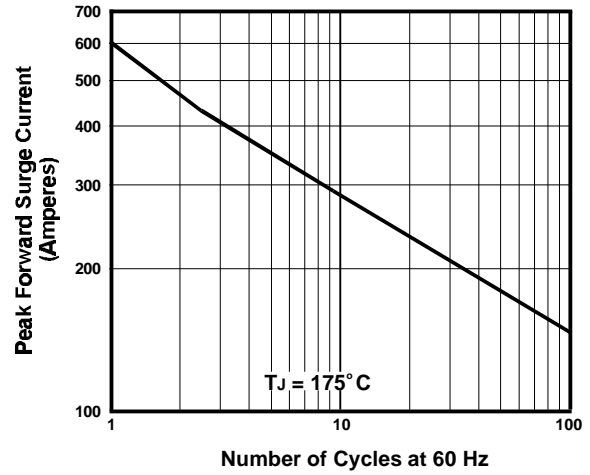

FIGURE 2. MAXIMUM NON-REPETITIVE SURGE CURRENT

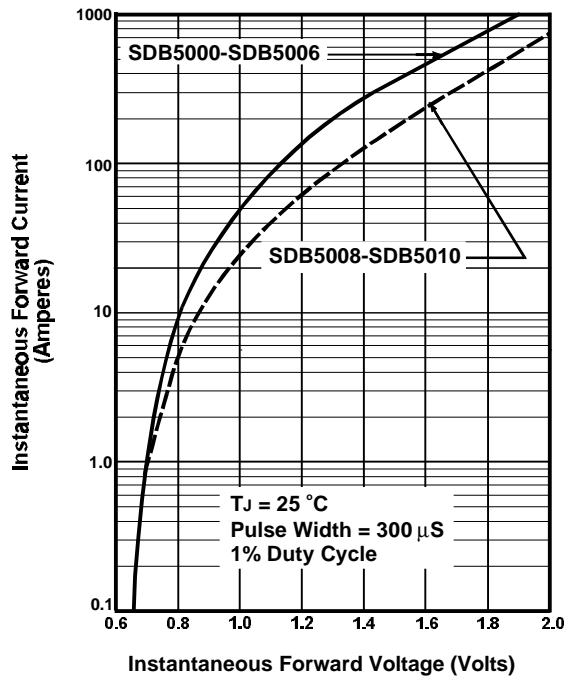

FIGURE 3. TYPICAL FORWARD CHARACTERISTIC PER DIODE

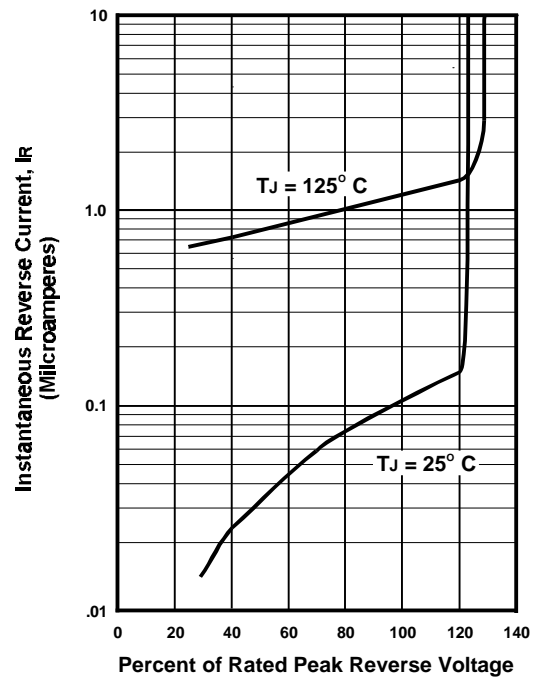
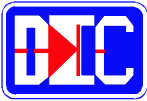

FIGURE 4. TYPICAL REVERSE CHARACTERISTICS



50 AMP SILICON BRIDGE RECTIFIERS

FEATURES

- VOID FREE VACUUM DIE SOLDERING FOR MAXIMUM MECHANICAL STRENGTH AND HEAT DISSIPATION (Solder Voids: Typical < 2%, Max. < 10% of Die Area)
- BUILT-IN STRESS RELIEF MECHANISM FOR SUPERIOR RELIABILITY AND PERFORMANCE
- INTEGRALLY MOLDED HEAT SINK PROVIDES VERY LOW THERMAL RESISTANCE FOR MAXIMUM HEAT DISSIPATION
- **UL RECOGNIZED - FILE #E141956**

MECHANICAL DATA

- Case: Molded plastic, U/L Flammability Rating 94V-0
- Terminals: Round silver plated copper pins or fast-on terminals
- Soldering: Per MIL-STD 202 Method 208 guaranteed
- Polarity: Marked on side of case
- Mounting Position: Any. Through hole for #8 screw.
Max. mounting torque = 20 in-lb.
- Weight: Fast-on Terminals - 0.7 Ounces (20.0 Grams)
Wire Leads - 0.55 Ounce (16.0 Grams)

MECHANICAL SPECIFICATION

SERIES: DB5000P - DB5010P and ADB5004P - ADB5008P

Suffix "P" indicates molded PLASTIC with integrally mounted Heat Sink

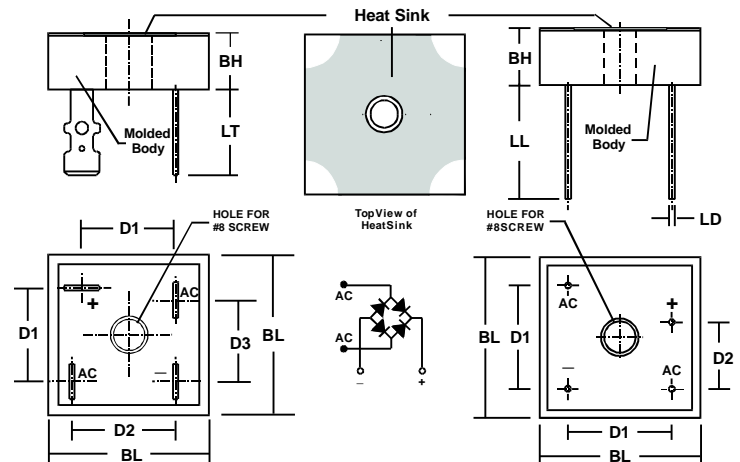

SYM	MILLIMETERS		INCHES	
	MIN	MAX	MIN	MAX
BL	28.4	28.7	1.12	1.13
BH	9.6	9.8	0.38	0.39
D1	15.7	16.7	0.62	0.66
D2	17.5	18.5	0.69	0.73
D3	13.5	14.5	0.53	0.57
LT	n/a	15.2	n/a	0.6

SYM	MILLIMETERS		INCHES	
	MIN	MAX	MIN	MAX
BL	28.4	28.7	1.12	1.13
BH	9.6	9.8	0.38	0.39
D1	17.5	18.5	0.69	0.73
D2	10.9	11.9	0.43	0.47
LL	20.6	n/a	0.81	n/a
LD	1.0	1.1	0.039	0.042

Suffix "T" indicates FAST-ON TERMINALS

Suffix "W" indicates WIRE LEADS

MAXIMUM RATINGS & ELECTRICAL CHARACTERISTICS

Ratings at 25 °C ambient temperature unless otherwise specified. Single phase, half wave, 60Hz, resistive or inductive load. For capacitive loads, derate current by 20%.

PARAMETER (TEST CONDITIONS)	SYMBOL	RATINGS										UNITS
		CONTROLLED AVALANCHE			NON-CONTROLLED AVALANCHE							
		ADB 5004P	ADB 5006P	ADB 5008P	DB 5000P	DB 5001P	DB 5002P	DB 5004P	DB 5006P	DB 5008P	DB 5010P	
Series Number												
Maximum DC Blocking Voltage	V _{RM}											VOLTS
Working Peak Reverse Voltage	V _{RWM}	400	600	800	50	100	200	400	600	800	1000	
Maximum Peak Recurrent Reverse Voltage	V _{RRM}											
RMS Reverse Voltage	V _{R (RMS)}	280	420	560	35	70	140	280	420	560	700	
Rating for Fusing (Non-repetitive; 1ms < t < 8.3ms)	I ² t	1000										AMPS ² SEC
Peak Forward Surge Current. Single 60Hz Half-Sine Wave Superimposed on Rated Load (JEDEC Method). T _J = 175° C	I _{FSM}	600										AMPS
Average Forward Rectified Current @ T _c = 55° C	I _o	50										
Junction Operating and Storage Temperature Range	T _J , T _{STG}	-55 to +175										°C
Minimum Avalanche Voltage	V _{(BR) Min}	450	650	850	n/a							VOLTS
Maximum Avalanche Voltage	V _{(BR) Max}	900	1100	1300	n/a							
Forward Voltage Drop (Per Diode) at 20 Amps DC	V _{FM} Max. Typ.	0.96	1.00				0.96		1.00			
		0.93	0.97				0.93		0.97			
Maximum Reverse Current at Rated V _{RM}	I _{RM}	2										μA
		20										
Minimum Insulation Breakdown Voltage (Circuit to Case)	V _{ISO}	2500										VOLTS
Typical Thermal Resistance, Junction to Case	R _{θJC}	1.10										°C/W

3.01 5000p

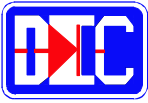

50 AMP SILICON BRIDGE RECTIFIERS

RATING & CHARACTERISTIC CURVES FOR SERIES DB5000P - DB5010P and SERIES ADB5004P - ADB5008P

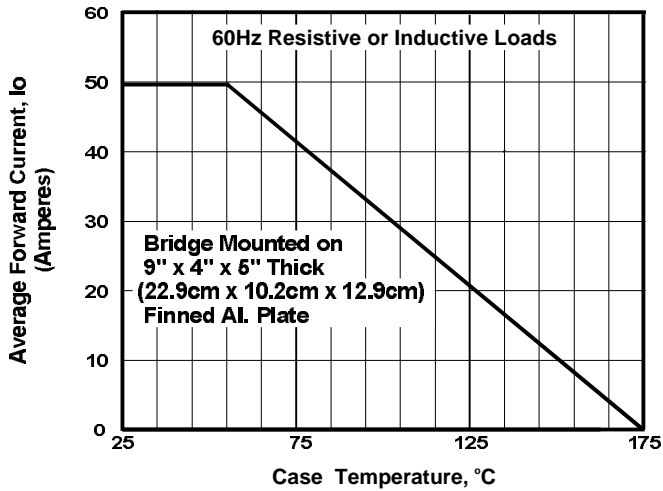

FIGURE 1. FORWARD CURRENT DERATING CURVE

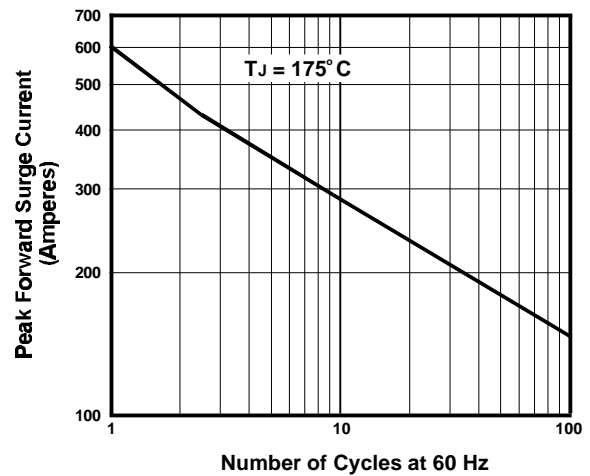

FIGURE 2. MAXIMUM NON-REPETITIVE SURGE CURRENT

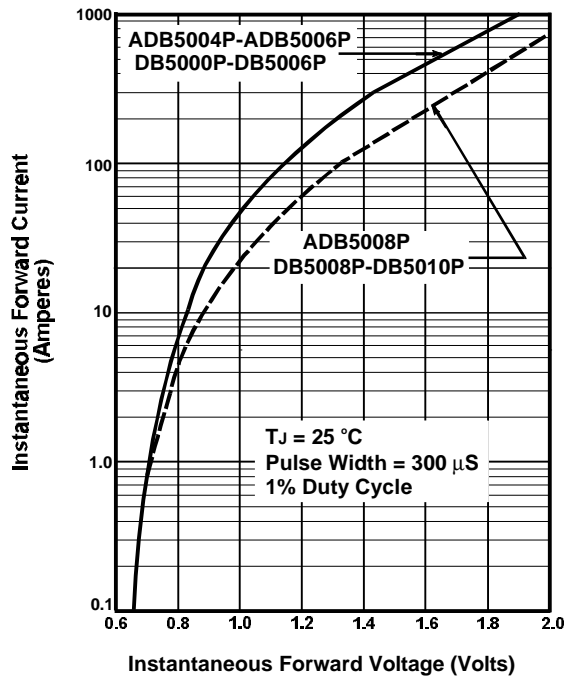

FIGURE 3. TYPICAL FORWARD CHARACTERISTIC PER DIODE

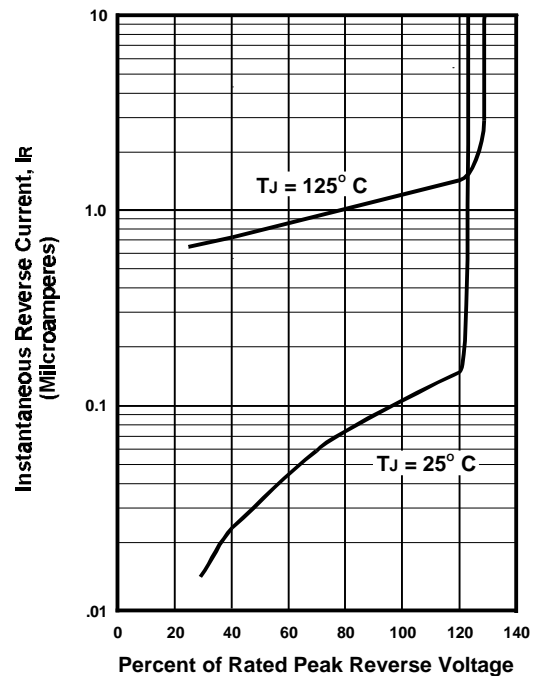

FIGURE 4. TYPICAL REVERSE CHARACTERISTICS

SECTION F

RESERVED

SECTION G

FAST RECOVERY

FULL WAVE

BRIDGE RECTIFIERS

DUAL IN-LINE PACKAGE

1 AMPERE

50 to 1000 VOLTS



CYLINDRICAL PACKAGE

1.5 AMPERES

50 to 1000 VOLTS



VERTICAL, SIDE LOOKING, PACKAGE

2 AMPERES

50 to 1000 VOLTS

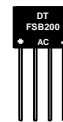

RECTANGULAR HORIZONTAL PACKAGE

3 to 6 AMPERES

50 to 1000 VOLTS



RECTANGULAR HORIZONTAL PACKAGES

25 to 35 AMPERES

50 to 1000 VOLTS

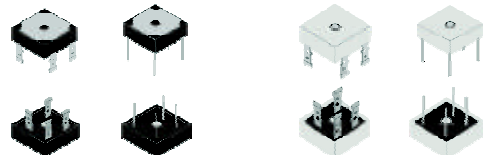



1 AMP FAST RECOVERY BRIDGE RECTIFIERS

FEATURES

- PRV Ratings from 50 to 1000 Volts
- Surge overload rating to 50 Amps peak
- Reliable low cost molded plastic construction
- Ideal for printed circuit board applications
- Fast switching for high efficiency

UL RECOGNIZED - FILE #E124962

MECHANICAL DATA

- Case: Molded plastic, U/L Flammability Rating 94V-0
- Terminals: Rectangular pins
- Soldering: Per MIL-STD 202 Method 208 guaranteed
- Polarity: Marked on case
- Mounting Position: Any
- Weight: 0.05 Ounces (1.3 Grams)

MECHANICAL SPECIFICATION

ACTUAL SIZE OF THE FDI PACKAGE

SERIES FDI100 - FDI110

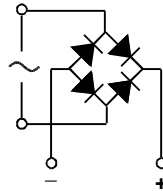
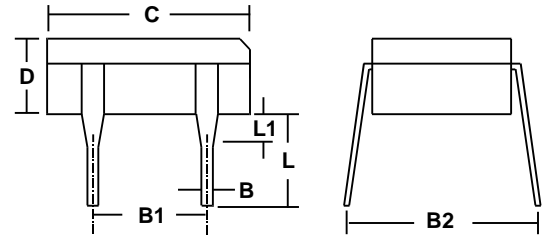
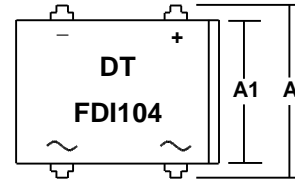
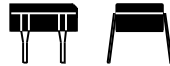

Sym	Minimum		Maximum	
	in	mm	in	mm
A	0.290	7.4	0.310	8.9
A1	0.245	6.2	0.255	6.5
B	0.016	0.41	0.020	0.51
B1	0.195	5.0	0.205	5.2
B2	0.300	7.6	0.350	8.9
C	0.355	9.3	0.365	9.3
D	0.125	3.2	0.135	3.4
L	0.155	3.9	0.165	4.3
L1	0.060*	1.5*		

* This dimension is "Typical".

MAXIMUM RATINGS & ELECTRICAL CHARACTERISTICS

Ratings at 25 °C ambient temperature unless otherwise specified.
 Single phase, half wave, 60Hz, resistive or inductive load.
 For capacitive loads, derate current by 20%.

PARAMETER (TEST CONDITIONS)	SYMBOL	RATINGS							UNITS
		FDI 100	FDI 101	FDI 102	FDI 104	FDI 106	FDI 108	FDI 110	
Series Number									
Maximum DC Blocking Voltage	V _{RM}	50	100	200	400	600	800	1000	VOLTS
Maximum RMS Voltage	V _{RMS}	35	70	140	280	420	560	700	
Maximum Peak Recurrent Reverse Voltage	V _{RRM}	50	100	200	400	600	800	1000	
Average Forward Rectified Current @ T _A = 40 °C	I _O	1							AMPS
Peak Forward Surge Current (8.3mS single half sine wave superimposed on rated load)	I _{FSM}	50							
Maximum Forward Voltage at 1 Amp DC	V _{FM}	1.3							VOLTS
Maximum Average DC Reverse Current @ T _A = 25 °C	I _{RM}	10							μA
At Rated DC Blocking Voltage @ T _A = 100 °C		1							
Maximum Reverse Recovery Time (Note 1) @ T _J = 25 °C	T _{RR}	200		300		500		nS	
Maximum Thermal Resistance, Junction to Ambient (Note 2)	R _{θJA}	40							°C/W
Junction Operating and Storage Temperature Range	T _J , T _{STG}	-55 to +150							°C

NOTES: (1) T_J=25°C, I_F=0.5A, I_R=1A, I_{RR}=0.25A

(2) Thermal resistance from junction to ambient with bridge mounted on PC Board with 0.5" sq. (13mm sq.) copper pads

3.01015d

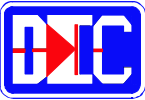

1.5 AMP FAST RECOVERY BRIDGE RECTIFIERS

FEATURES

- PRV Ratings from 50 to 1000 Volts
- Surge overload rating to 45 Amps peak
- Reliable low cost molded plastic construction
- Ideal for printed circuit board applications
- Fast switching for high efficiency

UL RECOGNIZED - FILE #E141956

MECHANICAL DATA

- Case: Molded plastic, U/L Flammability Rating 94V-0
- Terminals: Round silver plated pins
- Soldering: Per MIL-STD 202 Method 208 guaranteed
- Polarity: Marked on case
- Mounting Position: Any
- Weight: 0.05 Ounces (1.3 Grams)

MECHANICAL SPECIFICATION

ACTUAL SIZE OF
WB PACKAGE

SERIES FWB150 - FWB1510

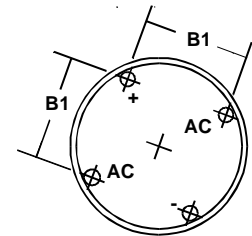
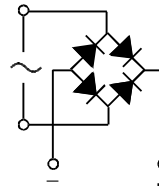
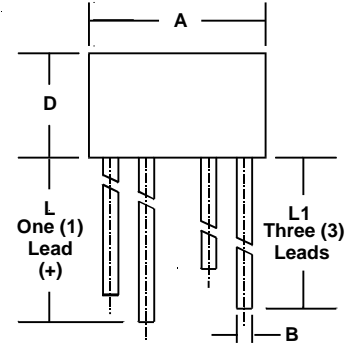

SYM	MILLIMETERS		INCHES	
	MIN	MAX	MIN	MAX
A	8.6	8.89	0.340	0.350
B	0.76	0.81	0.030	0.032
B1	4.6	5.6	0.180	0.220
D	5.1	5.6	0.200	0.220
L	30.5	n/a	1.20	n/a
L1	25.4	n/a	1.0	n/a

MAXIMUM RATINGS & ELECTRICAL CHARACTERISTICS

Ratings at 25 °C ambient temperature unless otherwise specified.
 Single phase, half wave, 60Hz, resistive or inductive load.
 For capacitive loads, derate current by 20%.

PARAMETER (TEST CONDITIONS)	SYMBOL	RATINGS							UNITS
		FWB 150	FWB 151	FWB 152	FWB 154	FWB 156	FWB 158	FWB 1510	
Series Number									
Maximum DC Blocking Voltage	V _{RM}	50	100	200	400	600	800	1000	VOLTS
Maximum RMS Voltage	V _{RMS}	35	70	140	280	420	560	700	
Maximum Peak Recurrent Reverse Voltage	V _{RRM}	50	100	200	400	600	800	1000	
Average Forward Rectified Current @ T _c = 55 °C	I _O	1.5							AMPS
Peak Forward Surge Current (8.3mS single half sine wave superimposed on rated load)	I _{FSM}	45							
Maximum Forward Voltage (Per Diode) at 1 Amp DC	V _{FM}	1.3							VOLTS
Maximum Average DC Reverse Current at Rated DC Blocking Voltage (Per Bridge Element) @ T _A = 25 °C @ T _A = 100 °C	I _{RM}	10 1							μA mA
Maximum Reverse Recovery Time (Note 1)	T _{RR}	200		300		500		nS	
Thermal Energy (Rating for Fusing, t < 8.3 mS)	I ² t	6.6							AMPS ² SEC
Typical Thermal Resistance, Junction to Ambient (Note 2)	R _{θJA}	40							°C/W
Junction Operating and Storage Temperature Range	T _J , T _{STG}	-55 to +150							°C

NOTES: (1) T_J=25°C, I_F=0.5A, I_R=1A, I_{RR}=0.25A
 (2) Mounted on PC Board with 0.2" sq. (5.5mm sq.) copper pads and lead length of 0.375" (9.5mm)

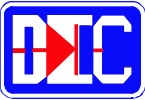

2 AMP FAST RECOVERY BRIDGE RECTIFIERS

FEATURES

- PRV Ratings from 50 to 1000 Volts
- Surge overload rating to 50 Amps peak
- Reliable low cost molded plastic construction
- Ideal for printed circuit board applications
- Fast switching for high efficiency
- **UL RECOGNIZED - FILE #E124962**

MECHANICAL DATA

- Case: Molded plastic, U/L Flammability Rating 94V-0
- Terminals: Rectangular pins
- Soldering: Per MIL-STD 202 Method 208 guaranteed
- Polarity: Marked on case
- Mounting Position: Any
- Weight: 0.1 Ounces (2.8 Grams)

MECHANICAL SPECIFICATION

ACTUAL SIZE OF SB2 PACKAGE

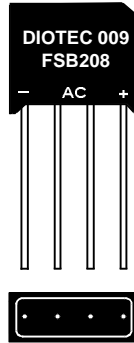

SERIES FSB200 - FSB210

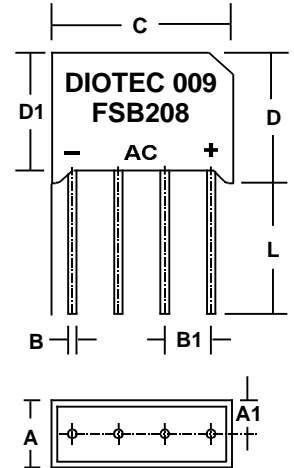

SYM	MILLIMETERS		INCHES	
	MIN	MAX	MIN	MAX
A	5.99	7.01	0.236	0.276
A1	2.99	3.51	0.118	0.138
B	0.71	0.89	0.028	0.035
B1	3.55	4.00	0.140	0.160
C	16.0	18.0	0.63	0.71
D	14.0	15.0	0.55	0.59
D1	13.2	13.7	0.52	0.54
L	12.7	n/a	0.50	n/a

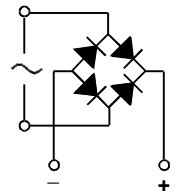

MAXIMUM RATINGS & ELECTRICAL CHARACTERISTICS

Ratings at 25 °C ambient temperature unless otherwise specified.
 Single phase, half wave, 60Hz, resistive or inductive load.
 For capacitive loads, derate current by 20%.

PARAMETER (TEST CONDITIONS)	SYMBOL	RATINGS							UNITS
		FSB 200	FSB 201	FSB 202	FSB 204	FSB 206	FSB 208	FSB 210	
Series Number									
Maximum DC Blocking Voltage	V _{RM}	50	100	200	400	600	800	1000	VOLTS
Maximum RMS Voltage	V _{RMS}	35	70	140	280	420	560	700	
Maximum Peak Recurrent Reverse Voltage	V _{RRM}	50	100	200	400	600	800	1000	
Average Forward Rectified Current @ T _A = 55 °C	I _O	2							AMPS
Peak Forward Surge Current (8.3mS single half sine wave superimposed on rated load)	I _{FSM}	50							
Maximum Forward Voltage at 1 Amp DC	V _{FM}	1							VOLTS
Maximum Average DC Reverse Current @ T _A = 25 °C	I _{RM}	10							μA
At Rated DC Blocking Voltage @ T _A = 125 °C		500							
Maximum Reverse Recovery Time (Note 1) @ T _J = 25 °C	T _{RR}	200		300		500		nS	
Maximum Thermal Resistance, Junction to Ambient (Note 2)	R _{θJA}	30							°C/W
Junction Operating and Storage Temperature Range	T _J , T _{STG}	-55 to +150							°C

NOTES: (1) T_J = 25°C, I_F = 0.5A, I_R = 1A, I_{RR} = 0.25A
 (2) Bridge mounted on PC Board with 0.47" sq. (12mm sq.) copper pads

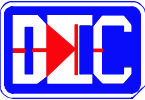

3 AMP FAST RECOVERY BRIDGE RECTIFIERS

FEATURES

- PRV Ratings from 50 to 1000 Volts
- Surge overload rating to 50 Amps peak
- Reliable low cost molded plastic construction
- Ideal for printed circuit board applications
- Fast switching for high efficiency
- **UL RECOGNIZED - FILE #E124962**

MECHANICAL DATA

- Case: Molded plastic, U/L Flammability Rating 94V-0
- Terminals: Round silver plated copper pins
- Soldering: Per MIL-STD 202 Method 208 guaranteed
- Polarity: Marked on side of case; positive lead at beveled corner
- Mounting Position: Any. Through hole provided for #6 screw
- Weight: 0.11 Ounces (3.36 Grams)

MECHANICAL SPECIFICATION

ACTUAL SIZE OF
FDB PACKAGE

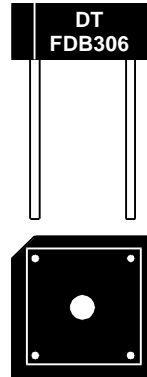

SERIES FDB300 - FDB310

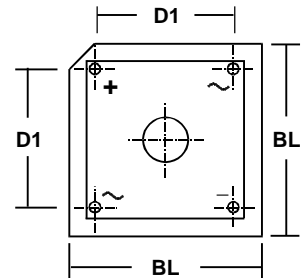
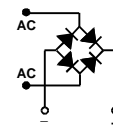
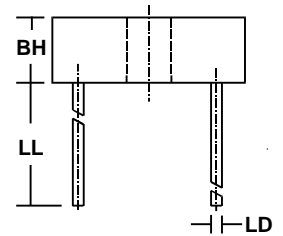

SYM	MILLIMETERS		INCHES	
	MIN	MAX	MIN	MAX
BL	14.7	15.7	0.58	0.62
BH	4.8	5.3	0.19	0.21
D1	10.3	11.3	0.405	0.445
LL	19.0	n/a	0.75	n/a
LD	0.7	0.9	0.028	0.035

MAXIMUM RATINGS & ELECTRICAL CHARACTERISTICS

Ratings at 25 °C ambient temperature unless otherwise specified.
 Single phase, half wave, 60Hz, resistive or inductive load.
 For capacitive loads, derate current by 20%.

PARAMETER (TEST CONDITIONS)	SYMBOL	RATINGS							UNITS
		FDB 300	FDB 301	FDB 302	FDB 304	FDB 306	FDB 308	FDB 310	
Series Number									
Maximum DC Blocking Voltage	V _{RM}	50	100	200	400	600	800	1000	VOLTS
Maximum RMS Voltage	V _{RMS}	35	70	140	280	420	560	700	
Maximum Peak Recurrent Reverse Voltage	V _{RRM}	50	100	200	400	600	800	1000	
Average Forward Rectified Current @ T _c = 50 °C	I _O	2							AMPS
Peak Forward Surge Current (8.3mS single half sine wave superimposed on rated load)	I _{FSM}	50							
Maximum Forward Voltage (Per Diode) at 1.5 Amps DC	V _{FM}	1.3							VOLTS
Maximum Average DC Reverse Current at Rated DC Blocking Voltage @ T _A = 25 °C @ T _A = 100 °C	I _{RM}	10 1							μA mA
Maximum Reverse Recovery Time (Note 1)	T _{RR}	200		300		500		nS	
Thermal Energy (Rating for Fusing, t < 8.3 mS)	I ² t	10							AMPS ² SEC
Maximum Thermal Resistance, Junction to Case (Note 2)	R _{θJC}	2.5							°C/W
Junction Operating and Storage Temperature Range	T _J , T _{STG}	-55 to +150							°C

NOTES: (1) T_J=25°C, I_F=0.5A, I_R=1A, I_{RR}=0.25A
 (2) Bridge mounted on 4.0" sq. x 0.11" thick (10.5cm sq. x 0.3cm) aluminum plate

3.01031db

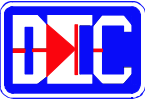

6 AMP FAST RECOVERY BRIDGE RECTIFIERS

FEATURES

- PRV Ratings from 50 to 1000 Volts
- Surge overload rating to 90 Amps peak
- Reliable low cost molded plastic construction
- Ideal for printed circuit board applications
- Fast switching for high efficiency

UL RECOGNIZED - FILE #E124962

MECHANICAL DATA

- Case: Molded plastic, U/L Flammability Rating 94V-0
- Terminals: Round silver plated copper pins
- Soldering: Per MIL-STD 202 Method 208 guaranteed
- Polarity: Marked on side of case; positive lead at bevelled corner
- Mounting Position: Any. Through hole provided for #6 screw
- Weight: 0.11 Ounces (3.36 Grams)

MECHANICAL SPECIFICATION

ACTUAL SIZE OF
FDB PACKAGE

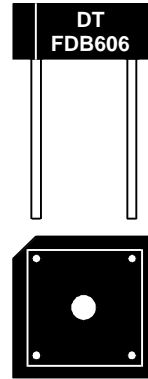

SERIES FDB600 - FDB610

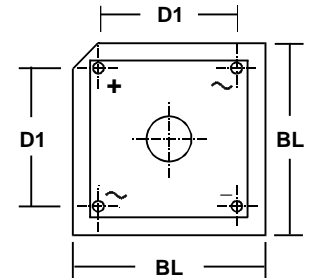
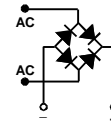
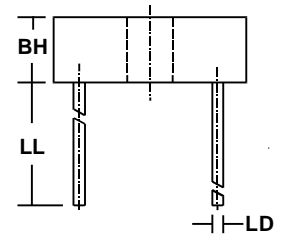

SYM	MILLIMETERS		INCHES	
	MIN	MAX	MIN	MAX
BL	14.7	15.7	0.58	0.62
BH	5.8	6.9	0.23	0.27
D1	10.3	11.3	0.405	0.445
LL	19.0	n/a	0.75	n/a
LD	1.0	1.1	0.039	0.042

MAXIMUM RATINGS & ELECTRICAL CHARACTERISTICS

Ratings at 25 °C ambient temperature unless otherwise specified.
 Single phase, half wave, 60Hz, resistive or inductive load.
 For capacitive loads, derate current by 20%.

PARAMETER (TEST CONDITIONS)	SYMBOL	RATINGS							UNITS
		FDB 600	FDB 601	FDB 602	FDB 604	FDB 606	FDB 608	FDB 610	
Series Number									
Maximum DC Blocking Voltage	V _{RM}	50	100	200	400	600	800	1000	VOLTS
Maximum RMS Voltage	V _{RMS}	35	70	140	280	420	560	700	
Maximum Peak Recurrent Reverse Voltage	V _{RRM}	50	100	200	400	600	800	1000	
Average Forward Rectified Current @ T _c = 50 °C	I _O	6							AMPS
Peak Forward Surge Current (8.3mS single half sine wave superimposed on rated load)	I _{FSM}	90							
Maximum Forward Voltage (Per bridge Element) at 3 Amps DC	V _{FM}	1.3							VOLTS
Maximum Average DC Reverse Current At Rated DC Blocking Voltage (Per Bridge Element-Note 2)	I _{RM}	10							μA
		1							mA
Maximum Reverse Recovery Time (Note 1)	T _{RR}	200		300		500		nS	
Thermal Energy (Rating for Fusing, t < 8.3 mS)	I ² t	60							AMPS ² SEC
Typical Thermal Resistance, Junction to Case (Note 2)	R _{θJC}	8							°C/W
Junction Operating and Storage Temperature Range	T _J , T _{STG}	-55 to +150							°C

NOTES: (1) T_J=25°C, I_F=0.5A, I_R=1A, I_{RR}=0.25A
 (2) Bridge mounted on 4.0" sq. x 0.11" thick (10.5cm sq. x 0.3cm) aluminum plate

3.0106f0b

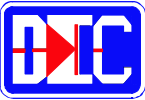

25 AMP FAST RECOVERY BRIDGE RECTIFIERS

FEATURES

- PRV Ratings from 50 to 1000 Volts
- Surge overload rating to 300 Amps peak
- Reliable low cost molded plastic construction
- Ideal for printed circuit board applications
- Fast switching for high efficiency
- **UL RECOGNIZED - FILE #E141956**

MECHANICAL DATA

- Case: Metal (Potting epoxy carries U/L Flammability Rating 94V-0)
- Terminals: Round silver plated copper pins or fast-on terminals
- Soldering: Per MIL-STD 202 Method 208 guaranteed
- Polarity: Marked on side of case
- Mounting Position: Any. Through hole for #8 screw.
Max. mounting torque = 20 in-lb.
- Weight: Fast-on Terminals - 1.1 Ounces (31.6 Grams)
Wire Leads - 0.95 Ounces (28.5 Grams)

MECHANICAL SPECIFICATION

SERIES FDB2500 - FDB2510

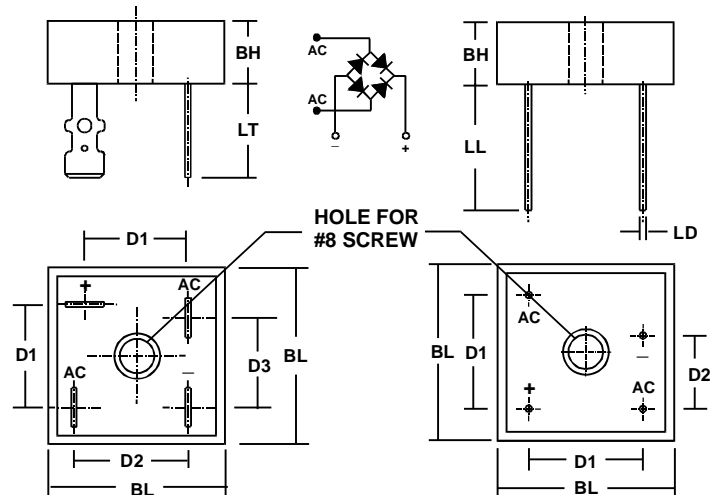

SYM	MILLIMETERS		INCHES	
	MIN	MAX	MIN	MAX
BL	28.4	28.7	1.12	1.13
BH	11.0	11.2	0.43	0.44
D1	15.7	16.7	0.62	0.66
D2	17.5	18.5	0.69	0.73
D3	13.5	14.5	0.53	0.57
LT	n/a	14.2	n/a	0.56

SYM	MILLIMETERS		INCHES	
	MIN	MAX	MIN	MAX
BL	28.4	28.7	1.12	1.13
BH	11.0	11.2	0.43	0.44
D1	17.5	18.5	0.69	0.73
D2	10.9	11.9	0.43	0.47
D3	20.6	n/a	0.81	n/a
LD	1.0	1.1	0.039	0.042

Suffix "T" indicates FAST-ON TERMINALS

Suffix "W" indicates WIRE LEADS

MAXIMUM RATINGS & ELECTRICAL CHARACTERISTICS

Ratings at 25 °C ambient temperature unless otherwise specified.
 Single phase, half wave, 60Hz, resistive or inductive load.
 For capacitive loads, derate current by 20%.

PARAMETER (TEST CONDITIONS)	SYMBOL	RATINGS								UNITS
		FDB 2500	FDB 2501	FDB 2502	FDB 2504	FDB 2506	FDB 2508	FDB 2510		
Series Number										
Maximum DC Blocking Voltage	V _{RM}	50	100	200	400	600	800	1000		VOLTS
Maximum RMS Voltage	V _{RMS}	35	70	140	280	420	560	700		
Maximum Peak Recurrent Reverse Voltage	V _{RRM}	50	100	200	400	600	800	1000		
Average Forward Rectified Current @ T _c = 55 °C	I _o	25								AMPS
Peak Forward Surge Current (8.3mS single half sine wave superimposed on rated load)	I _{FSM}	300								
Maximum Forward Voltage (Per Bridge Element) at 12.5 Amps DC	V _{FM}	1.3								VOLTS
Maximum Average DC Reverse Current at Rated DC Blocking Voltage (Per Bridge Element-Note 2)	I _{RM}	10 1								μA mA
Maximum Reverse Recovery Time (Note 1)	T _{RR}	200		300		500			nS	
Thermal Energy (Rating for Fusing, t < 8.3 mS)	I ² t	373								AMPS ² SEC
Typical Thermal Resistance, Junction to Case (Note 2)	R _{θJC}	1.6								°C/W
Junction Operating and Storage Temperature Range	T _J , T _{STG}	-55 to +150								°C

NOTES: (1) T_J=25°C, I_F=0.5A, I_R=1A, I_{RR}=0.25A
 (2) Bridge mounted on an 5" x 6" x 4.9" thick (12.7cm x 15.2cm x 12.4cm) finned aluminum plate

3.0125fdbm

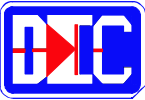

25 AMP FAST RECOVERY BRIDGE RECTIFIERS

FEATURES

- PRV Ratings from 50 to 1000 Volts
- Surge overload rating to 300 Amps peak
- Reliable low cost molded plastic construction
- Ideal for printed circuit board applications
- Fast switching for high efficiency
- **UL RECOGNIZED - FILE #E141956**

MECHANICAL DATA

- Case: Molded plastic, U/L Flammability Rating 94V-0
- Terminals: Round silver plated copper pins or fast-on terminals
- Soldering: Per MIL-STD 202 Method 208 guaranteed
- Polarity: Marked on side of case
- Mounting Position: Any. Through hole for #8 screw.
Max. mounting torque = 20 in-lb.
- Weight: Fast-on Terminals - 0.7 Ounces (20.0 Grams)
Wire Leads - 0.55 Ounces (16.0 Grams)

MECHANICAL SPECIFICATION

SERIES FDB2500P - FDB2510P

Suffix "P" indicates molded PLASTIC with integrally mounted Heat Sink

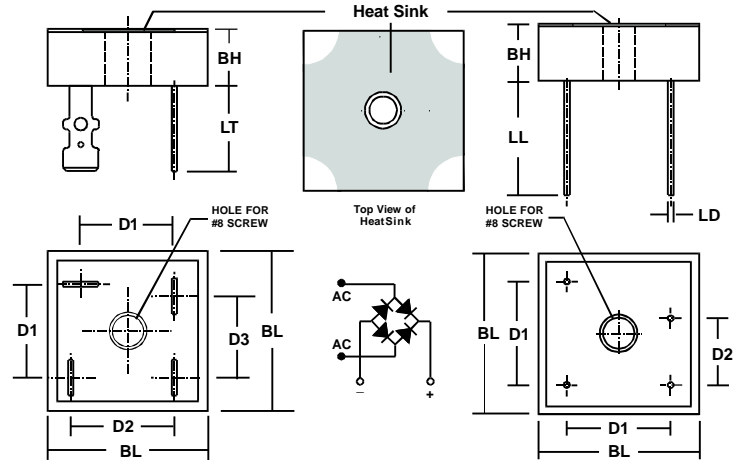

SYM	MILLIMETERS		INCHES	
	MIN	MAX	MIN	MAX
BL	28.4	28.7	1.12	1.13
BH	9.6	9.8	0.38	0.39
D1	15.7	16.7	0.62	0.66
D2	17.5	18.5	0.69	0.73
D3	13.5	14.5	0.53	0.57
LT	n/a	15.2	n/a	0.6

SYM	MILLIMETERS		INCHES	
	MIN	MAX	MIN	MAX
BL	28.4	28.7	1.12	1.13
BH	9.6	9.8	0.38	0.39
D1	17.5	18.5	0.69	0.73
D2	10.9	11.9	0.43	0.47
LL	20.6	n/a	0.81	n/a
LD	1.0	1.1	0.039	0.042

Suffix "T" indicates FAST-ON TERMINALS

Suffix "W" indicates WIRE LEADS

MAXIMUM RATINGS & ELECTRICAL CHARACTERISTICS

Ratings at 25 °C ambient temperature unless otherwise specified.
 Single phase, half wave, 60Hz, resistive or inductive load.
 For capacitive loads, derate current by 20%.

PARAMETER (TEST CONDITIONS)	SYMBOL	RATINGS								UNITS
		FDB 2500P	FDB 2501P	FDB 2502P	FDB 2504P	FDB 2506P	FDB 2508P	FDB 2510P		
Series Number										
Maximum DC Blocking Voltage	V _{RM}	50	100	200	400	600	800	1000		VOLTS
Maximum RMS Voltage	V _{RMS}	35	70	140	280	420	560	700		
Maximum Peak Recurrent Reverse Voltage	V _{RRM}	50	100	200	400	600	800	1000		
Average Forward Rectified Current @ T _c = 55 °C	I _O	25								AMPS
Peak Forward Surge Current (8.3mS single half sine wave superimposed on rated load)	I _{FSM}	300								
Maximum Forward Voltage (Per Bridge Element) at 12.5 Amps DC	V _{FM}	1.3								VOLTS
Maximum Average DC Reverse Current at Rated DC Blocking Voltage (Per bridge Element-Note 2)	I _{RM}	10 1								μA mA
Maximum Reverse Recovery Time (Note 1)	T _{RR}	200		300		500			nS	
Thermal Energy (Rating for Fusing, t < 8.3 mS)	I ² t	373								AMPS ² SEC
Typical Thermal Resistance, Junction to Case (Note 2)	R _{θJC}	1.2								°C/W
Junction Operating and Storage Temperature Range	T _J , T _{STG}	-55 to +150								°C

NOTES: (1) T_J=25°C, I_F=0.5A, I_R=1A, I_{RR}=0.25A
 (2) Bridge mounted on an 5" x 6" x 4.9" thick (12.7cm x 15.2cm x 12.4cm) finned aluminum plate

3.01250pp

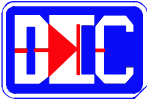

35 AMP FAST RECOVERY BRIDGE RECTIFIERS

FEATURES

- PRV Ratings from 50 to 1000 Volts
- Surge overload rating to 400 Amps peak
- Reliable low cost molded plastic construction
- Ideal for printed circuit board applications
- Fast switching for high efficiency

UL RECOGNIZED - FILE #E124962

MECHANICAL DATA

- Case: Metal (Potting epoxy carries U/L Flammability Rating 94V-0)
- Terminals: Round silver plated copper pins or fast-on terminals
- Soldering: Per MIL-STD 202 Method 208 guaranteed
- Polarity: Marked on side of case
- Mounting Position: Any. Through hole for #8 screw.
Max. mounting torque = 20 in-lb.
- Weight: Fast-on Terminals - 1.1 Ounces (31.6 Grams)
Wire Leads - 0.95 Ounces (28.5 Grams)

MECHANICAL SPECIFICATION

SERIES FDB3500 - FDB3510

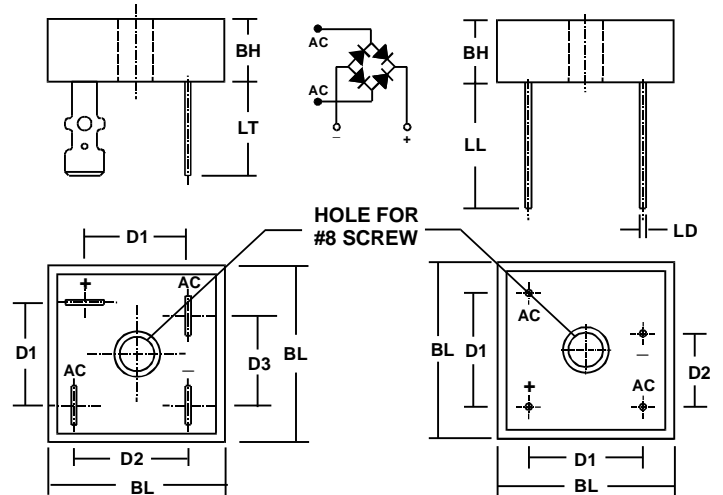

SYM	MILLIMETERS		INCHES	
	MIN	MAX	MIN	MAX
BL	28.4	28.7	1.12	1.13
BH	11.0	11.2	0.43	0.44
D1	15.7	16.7	0.62	0.66
D2	17.5	18.5	0.69	0.73
D3	13.5	14.5	0.53	0.57
LT	n/a	14.2	n/a	0.56

SYM	MILLIMETERS		INCHES	
	MIN	MAX	MIN	MAX
BL	28.4	28.7	1.12	1.13
BH	11.0	11.2	0.43	0.44
D1	17.5	18.5	0.69	0.73
D2	10.9	11.9	0.43	0.47
D3	20.6	n/a	0.81	n/a
LD	1.0	1.1	0.039	0.042

Suffix "T" indicates FAST-ON TERMINALS

Suffix "W" indicates WIRE LEADS

MAXIMUM RATINGS & ELECTRICAL CHARACTERISTICS

Ratings at 25 °C ambient temperature unless otherwise specified.
 Single phase, half wave, 60Hz, resistive or inductive load.
 For capacitive loads, derate current by 20%.

PARAMETER (TEST CONDITIONS)	SYMBOL	RATINGS								UNITS
		FDB 3500	FDB 3501	FDB 3502	FDB 3504	FDB 3506	FDB 3508	FDB 3510		
Series Number										
Maximum DC Blocking Voltage	V _{RM}	50	100	200	400	600	800	1000		VOLTS
Maximum RMS Voltage	V _{RMS}	35	70	140	280	420	560	700		
Maximum Peak Recurrent Reverse Voltage	V _{RRM}	50	100	200	400	600	800	1000		
Average Forward Rectified Current @ T _c = 55 °C	I _o	35								AMPS
Peak Forward Surge Current (8.3mS single half sine wave superimposed on rated load)	I _{FSM}	400								
Maximum Forward Voltage (Per Bridge Element) at 17.5 Amps DC	V _{FM}	1.3								VOLTS
Maximum Average DC Reverse Current at Rated DC Blocking Voltage (Per Bridge Element-Note 2)	I _{RM}	10 1								μA mA
Maximum Reverse Recovery Time (Note 1)	T _{RR}	200		300		500			nS	
Thermal Energy (Rating for Fusing, t < 8.3 mS)	I ² t	664								AMPS ² SEC
Typical Thermal Resistance, Junction to Case (Note 2)	R _{θJC}	1.6								°C/W
Junction Operating and Storage Temperature Range	T _J , T _{STG}	-55 to +150								°C

NOTES: (1) T_J=25°C, I_F=0.5A, I_R=1A, I_{RR}=0.25A
 (2) Bridge mounted on an 9" x 3" x 4.6" thick (22.9cm x 7.6cm x 11.7cm) finned aluminum plate

3.0135fdbm

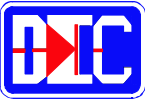

35 AMP FAST RECOVERY BRIDGE RECTIFIERS

FEATURES

- PRV Ratings from 50 to 1000 Volts
- Surge overload rating to 400 Amps peak
- Reliable low cost molded plastic construction
- Ideal for printed circuit board applications
- Fast switching for high efficiency

UL RECOGNIZED - FILE #E141956

MECHANICAL DATA

- Case: Molded plastic, U/L Flammability Rating 94V-0
- Terminals: Round silver plated copper pins or fast-on terminals
- Soldering: Per MIL-STD 202 Method 208 guaranteed
- Polarity: Marked on side of case
- Mounting Position: Any. Through hole for #8 screw.
Max. mounting torque = 20 in-lb.
- Weight: Fast-on Terminals - 0.7 Ounces (20.0 Grams)
Wire Leads - 0.55 Ounces (16.0 Grams)

MECHANICAL SPECIFICATION

SERIES FDB3500P - FDB3510P

Suffix "P" indicates molded PLASTIC with integrally mounted Heat Sink

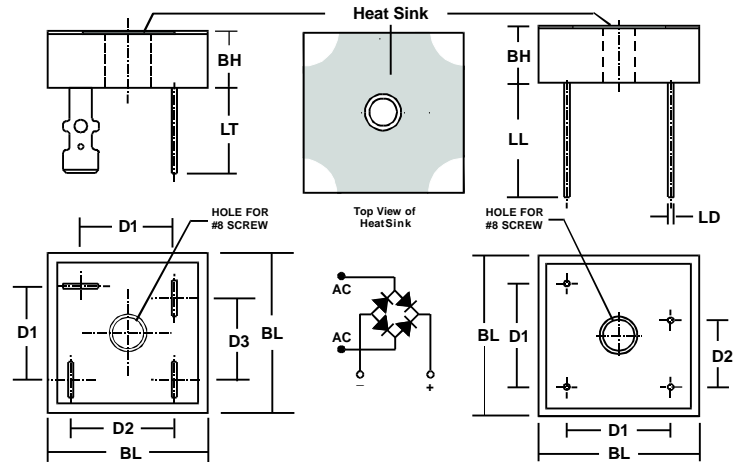

SYM	MILLIMETERS		INCHES	
	MIN	MAX	MIN	MAX
BL	28.4	28.7	1.12	1.13
BH	9.6	9.8	0.38	0.39
D1	15.7	16.7	0.62	0.66
D2	17.5	18.5	0.69	0.73
D3	13.5	14.5	0.53	0.57
LT	n/a	15.2	n/a	0.6

SYM	MILLIMETERS		INCHES	
	MIN	MAX	MIN	MAX
BL	28.4	28.7	1.12	1.13
BH	9.6	9.8	0.38	0.39
D1	17.5	18.5	0.69	0.73
D2	10.9	11.9	0.43	0.47
LL	20.6	n/a	0.81	n/a
LD	1.0	1.1	0.039	0.042

Suffix "T" indicates FAST-ON TERMINALS

Suffix "W" indicates WIRE LEADS

MAXIMUM RATINGS & ELECTRICAL CHARACTERISTICS

Ratings at 25 °C ambient temperature unless otherwise specified.
 Single phase, half wave, 60Hz, resistive or inductive load.
 For capacitive loads, derate current by 20%.

PARAMETER (TEST CONDITIONS)	SYMBOL	RATINGS								UNITS	
		FDB 3500P	FDB 3501P	FDB 3502P	FDB 3504P	FDB 3506P	FDB 3508P	FDB 3510P			
Series Number											
Maximum DC Blocking Voltage	V _{RM}	50	100	200	400	600	800	1000		VOLTS	
Maximum RMS Voltage	V _{RMS}	35	70	140	280	420	560	700			
Maximum Peak Recurrent Reverse Voltage	V _{RRM}	50	100	200	400	600	800	1000			
Average Forward Rectified Current @ T _c = 55 °C	I _O	35									AMPS
Peak Forward Surge Current (8.3mS single half sine wave superimposed on rated load)	I _{FSM}	400									
Maximum Forward Voltage, Per Diode, at 17.5 Amps DC	V _{FM}	1.3									VOLTS
Maximum Average DC Reverse Current at Rated DC Blocking Voltage Per Diode (Note 2)	I _{RM}	10									μA mA
		1									
Maximum Reverse Recovery Time (Note 1)	T _{RR}	200		300		500				nS	
Thermal Energy (Rating for Fusing, t < 8.3 mS)	I ² t	664									AMPS ² SEC
Typical Thermal Resistance, Junction to Case (Note 2)	R _{θJC}	1.2									°C/W
Operating and Storage Temperature Range	T _J , T _{STG}	-55 to +150									°C

NOTES: (1) T_J=25°C, I_F=0.5A, I_R=1A, I_{RR}=0.25A
 (2) Bridge mounted on an 9" x 3" x 4.6" thick (22.9cm x 7.6cm x 11.7cm) finned aluminum plate

SECTION H
***GENERAL PURPOSE
AND
FAST RECOVERY DIODES***

GENERAL PURPOSE DIODES

1-6 AMPERES
50 to 1000 VOLTS

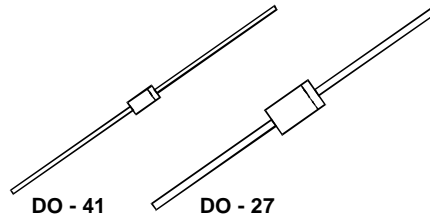

ULTRA FAST SWITCHING DIODES

0.150 AMPERES
75 VOLTS

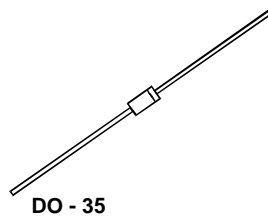

FAST RECOVERY SILICON DIODES

1-8 AMPERES
50 to 1000 VOLTS

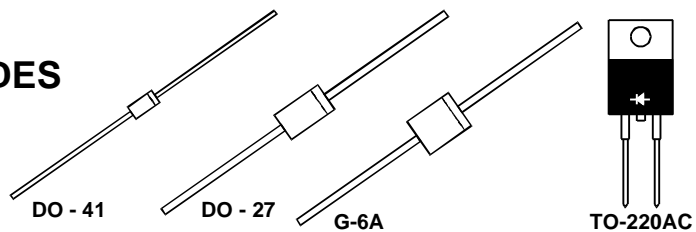

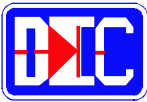

1 AMP GENERAL PURPOSE SILICON DIODES

FEATURES

- Low cost
- Low leakage
- Low forward voltage drop
- High current capacity
- Easily cleaned with freon, alcohol, chlorothene and similar solvents

MECHANICAL SPECIFICATION

ACTUAL SIZE OF
DO-41 PACKAGE

SERIES 1N4001 - 1N4007

DO - 41

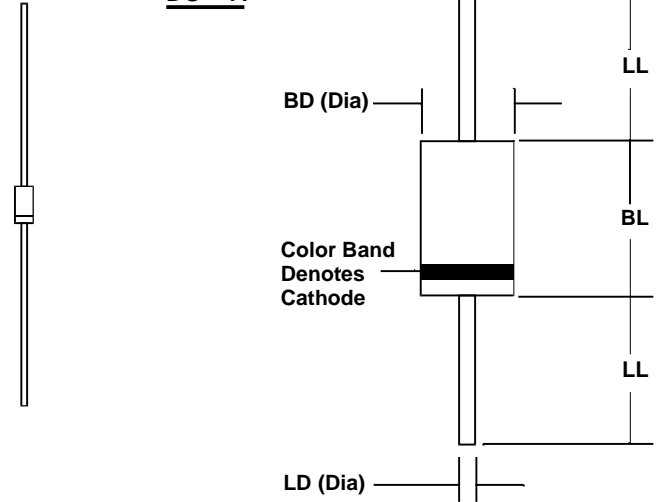

MECHANICAL DATA

- Case: JEDEC DO-41, molded plastic (U/L Flammability Rating 94V-0)
- Terminals: Plated axial leads
- Soldering: Per MIL-STD 202 Method 208 guaranteed
- Polarity: Color band denotes cathode
- Mounting Position: Any
- Weight: 0.012 Ounces (0.34 Grams)

Sym	Minimum		Maximum	
	In	mm	In	mm
BL	0.160	4.1	0.205	5.2
BD	0.103	2.6	0.107	2.7
LL	1.00	25.4		
LD	0.028	0.71	0.034	0.86

MAXIMUM RATINGS & ELECTRICAL CHARACTERISTICS

Ratings at 25 °C ambient temperature unless otherwise specified.
 Single phase, half wave, 60Hz, resistive or inductive load.
 For capacitive loads, derate current by 20%.

PARAMETER (TEST CONDITIONS)	SYMBOL	RATINGS							UNITS
		1N4001	1N4002	1N4003	1N4004	1N4005	1N4006	1N4007	
Series Number									
Maximum DC Blocking Voltage	V _{RM}	50	100	200	400	600	800	1000	VOLTS
Maximum RMS Voltage	V _{RMS}	35	70	140	280	420	560	700	
Maximum Peak Recurrent Reverse Voltage	V _{RRM}	50	100	200	400	600	800	1000	
Average Forward Rectified Current @ T _A = 75 °C (Lead length = 0.375 in. (9.5 mm))	I _o	1							AMPS
Peak Forward Surge Current (8.3 mSec single half sine wave superimposed on rated load)	I _{FSM}	50							
Maximum Forward Voltage at 1 Amp DC	V _{FM}	1							VOLTS
Maximum Full Cycle Reverse Current @ T _L = 75 °C (Note 1)	I _{RM(AV)}	30							μA
Maximum Average DC Reverse Current At Rated DC Blocking Voltage	I _{RM}	5							
Typical Thermal Resistance, Junction to Ambient (Note 1)	R _{θJA}	30							°C/W
Typical Junction Capacitance (Note 2)	C _J	26							pF
Operating and Storage Temperature Range	T _J , T _{STG}	-65 to +175							°C

NOTES: (1) Lead length = 0.375 in. (9.5 mm)
 (2) Measured at 1MHz & applied reverse voltage of 4 volts

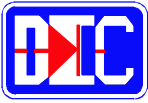

1 AMP GENERAL PURPOSE SILICON DIODES

RATING & CHARACTERISTIC CURVES FOR SERIES 1N4001 - 1N4007

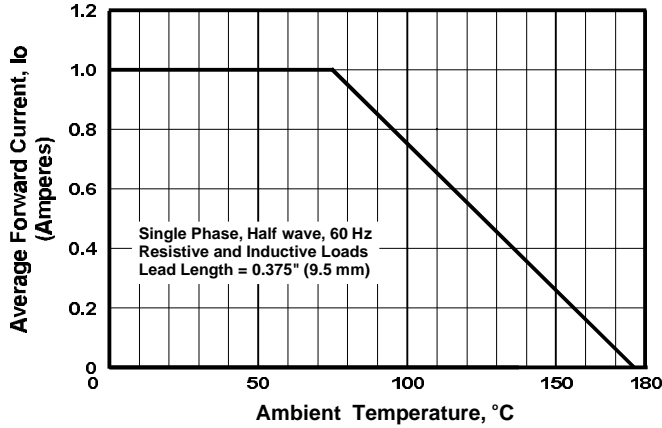

FIGURE 1. FORWARD CURRENT DERATING CURVE

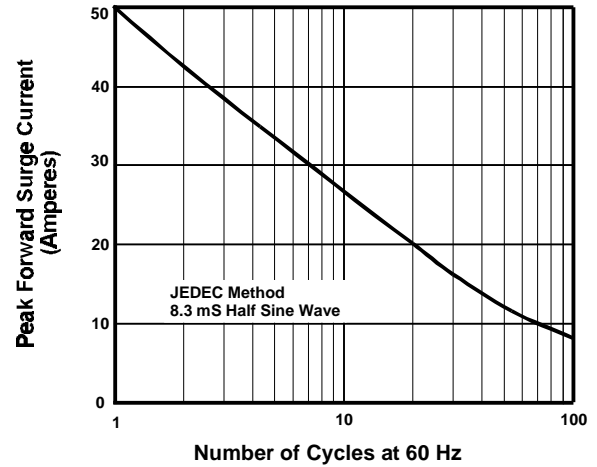

FIGURE 2. MAXIMUM NON-REPETITIVE SURGE CURRENT

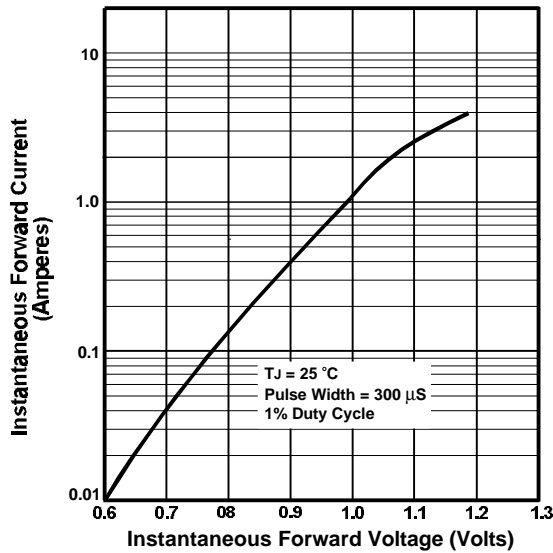

FIGURE 3. TYPICAL FORWARD CHARACTERISTIC PER DIODE

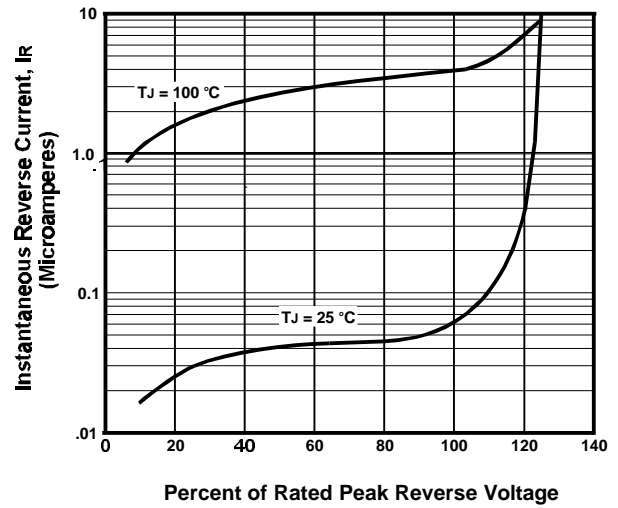

FIGURE 4. TYPICAL REVERSE CHARACTERISTICS

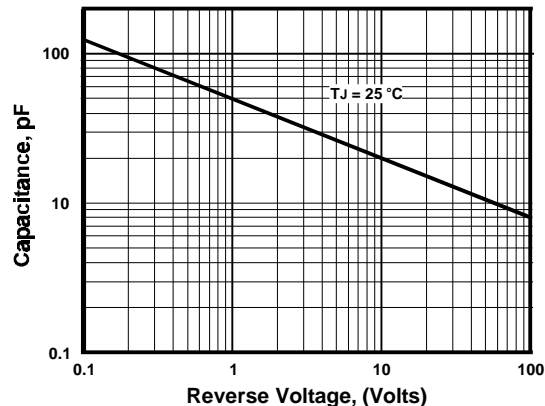

FIGURE 5. TYPICAL JUNCTION CAPACITANCE PER DIODE

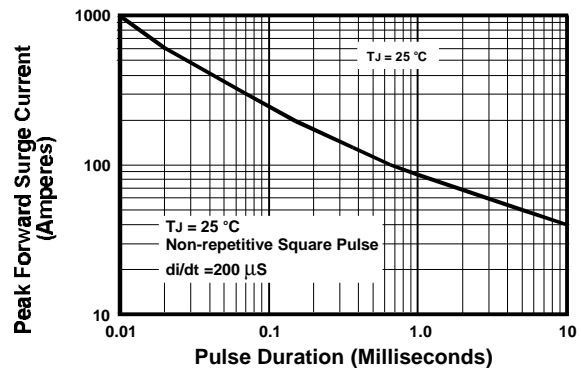
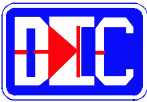

FIGURE 6. PEAK FORWARD SURGE CURRENT



1 AMP SOFT GLASS PASSIVATED SILICON DIODES

FEATURES

- PROPRIETARY **SOFT GLASS[®]** JUNCTION PASSIVATION FOR SUPERIOR RELIABILITY AND PERFORMANCE
- VOID FREE VACUUM DIE SOLDERING FOR MAXIMUM MECHANICAL STRENGTH AND HEAT DISSIPATION (Solder Voids: Typical $\leq 2\%$, Max. $\leq 10\%$ of Die Area)
- EXTREMELY LOW LEAKAGE AT HIGH TEMPERATURES
- LOW FORWARD VOLTAGE DROP
- 1A at $T_A = 75^\circ\text{C}$ WITH NO THERMAL RUNAWAY

MECHANICAL DATA

- Case: JEDEC DO-41, molded plastic (U/L Flammability Rating 94V-0)
- Terminals: Plated axial leads
- Soldering: Per MIL-STD 202 Method 208 guaranteed
- Polarity: Color band denotes cathode
- Mounting Position: Any
- Weight: 0.012 Ounces (0.34 Grams)

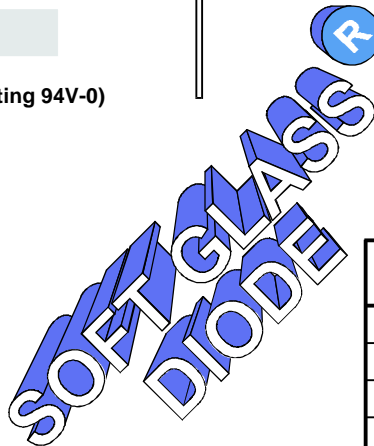

MECHANICAL SPECIFICATION

ACTUAL SIZE OF
DO-41 PACKAGE

SERIES 1N4001G - 1N4007G

DO - 41

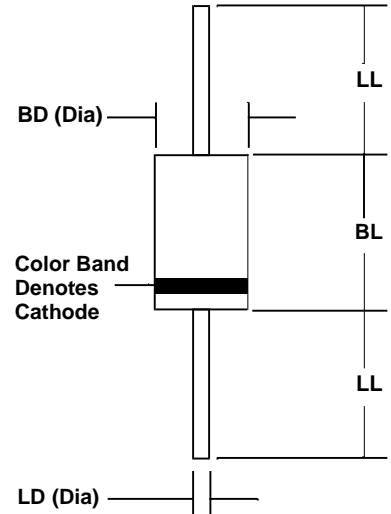

Sym	Minimum		Maximum	
	In	mm	In	mm
BL	0.160	4.1	0.205	5.2
BD	0.103	2.6	0.107	2.7
LL	1.00	25.4		
LD	0.028	0.71	0.034	0.86

MAXIMUM RATINGS & ELECTRICAL CHARACTERISTICS

Ratings at 25°C ambient temperature unless otherwise specified.
 Single phase, half wave, 60Hz, resistive or inductive load.
 For capacitive loads, derate current by 20%.

PARAMETER (TEST CONDITIONS)	SYMBOL	RATINGS							UNITS
		1N 4001G	1N 4002G	1N 4003G	1N 4004G	1N 4005G	1N 4006G	1N 4007G	
Maximum DC Blocking Voltage	V_{RM}	50	100	200	400	600	800	1000	VOLTS
Maximum RMS Voltage	V_{RMS}	35	70	140	280	420	560	700	
Maximum Peak Recurrent Reverse Voltage	V_{RRM}	50	100	200	400	600	800	1000	
Average Forward Rectified Current @ $T_A = 75^\circ\text{C}$ (Lead length = 0.375 in. (9.5 mm))	I_o	1							AMPS
Peak Forward Surge Current (8.3 mSec single half sine wave superimposed on rated load)	I_{FSM}	50							
Maximum Forward Voltage at 1 Amp DC	V_{FM}	1							VOLTS
Maximum Full Cycle Reverse Current @ $T_L = 75^\circ\text{C}$ (Note 1)	$I_{RM(AV)}$	10							μA
Maximum Average DC Reverse Current At Rated DC Blocking Voltage	I_{RM}	1 20							
Typical Thermal Resistance, Junction to Ambient (Note 1)	$R_{\theta JA}$	30							$^\circ\text{C/W}$
Typical Junction Capacitance (Note 2)	C_J	10							pF
Operating and Storage Temperature Range	T_J, T_{STG}	-65 to +175							$^\circ\text{C}$

NOTES: (1) Lead length = 0.375 in. (9.5 mm)
 (2) Measured at 1MHz & applied reverse voltage of 4 volts

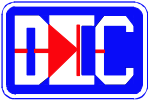

1 AMP SOFT GLASS PASSIVATED SILICON DIODES

RATING & CHARACTERISTIC CURVES FOR SERIES 1N4001G - 1N4007G

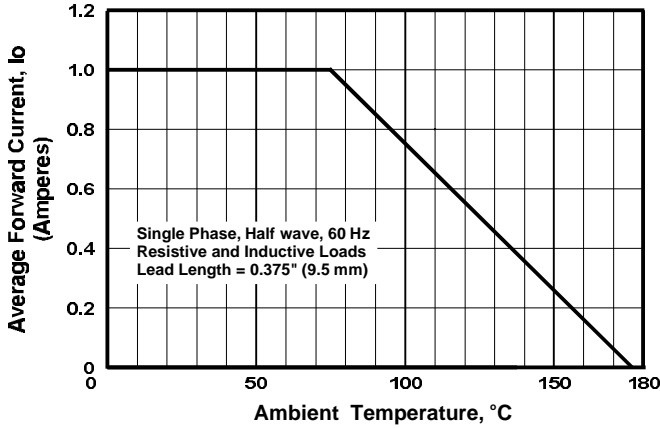

FIGURE 1. FORWARD CURRENT DERATING CURVE

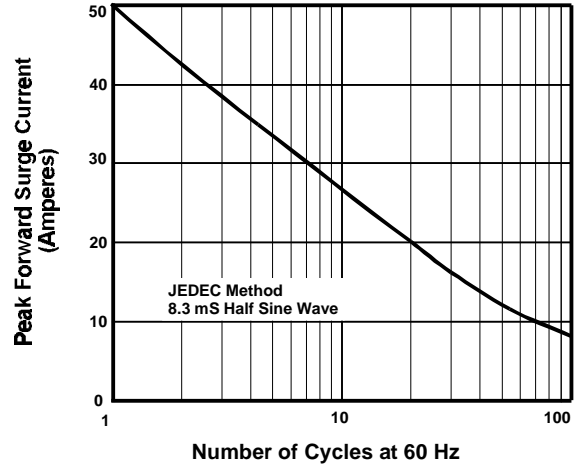

FIGURE 2. MAXIMUM NON-REPETITIVE SURGE CURRENT

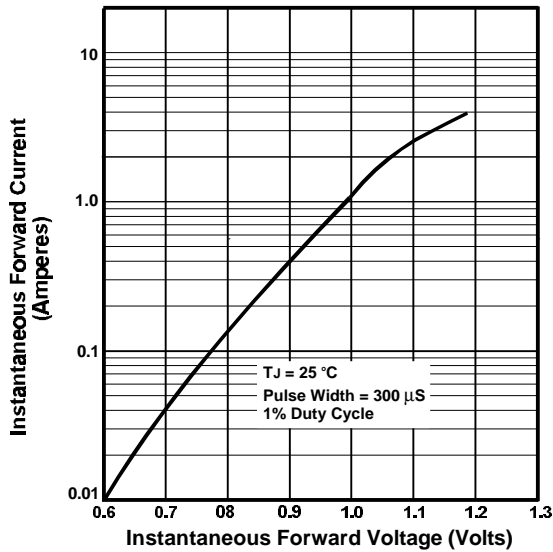

FIGURE 3. TYPICAL FORWARD CHARACTERISTIC PER DIODE

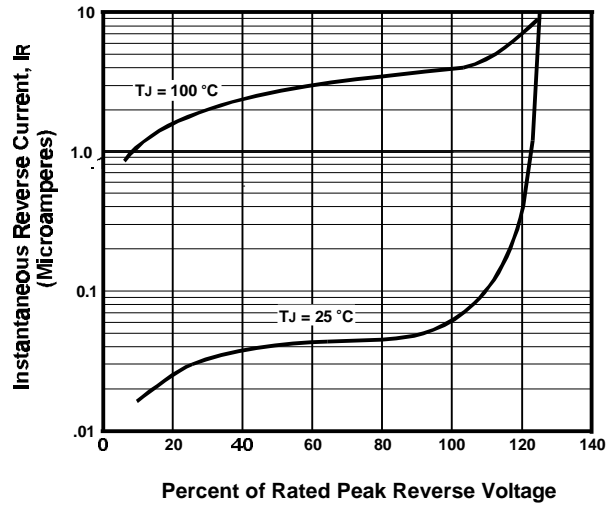

FIGURE 4. TYPICAL REVERSE CHARACTERISTICS

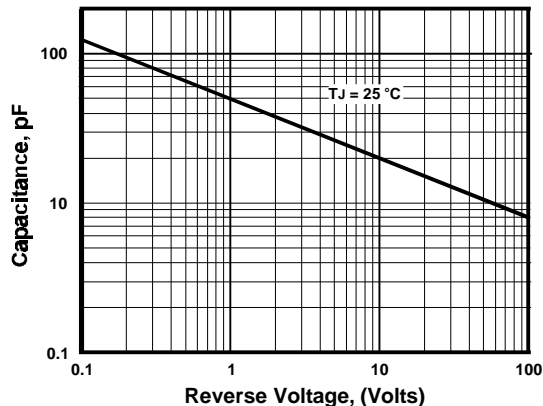

FIGURE 5. TYPICAL JUNCTION CAPACITANCE PER DIODE

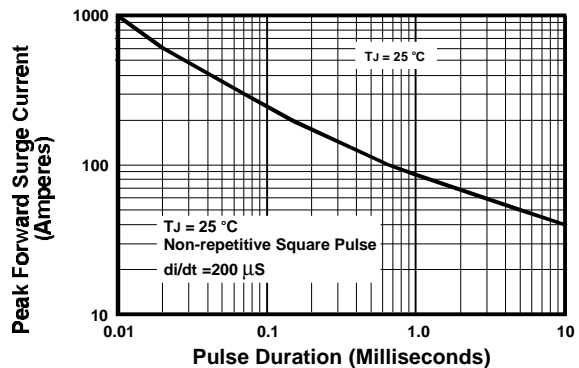
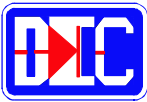

FIGURE 6. PEAK FORWARD SURGE CURRENT



1 AMP HIGH RELIABILITY SILICON DIODES

FEATURES

- PROPRIETARY **SOFT GLASS[®]** JUNCTION PASSIVATION FOR SUPERIOR RELIABILITY AND PERFORMANCE
- VOID FREE VACUUM DIE SOLDERING FOR MAXIMUM MECHANICAL STRENGTH AND HEAT DISSIPATION (Solder Voids: Typical $\leq 2\%$, Max. $\leq 10\%$ of Die Area)
- EXTREMELY LOW LEAKAGE AT HIGH TEMPERATURES
- LOW FORWARD VOLTAGE DROP
- 1A at $T_A = 75^\circ\text{C}$ WITH NO THERMAL RUNAWAY

MECHANICAL DATA

- Case: JEDEC DO-41, molded silica glass (U/L Flammability Rating 94V-0)
- Terminals: Plated axial leads
- Soldering: Per MIL-STD 202 Method 208 guaranteed
- Polarity: Color band denotes cathode
- Mounting Position: Any
- Weight: 0.012 Ounces (0.34 Grams)

MECHANICAL SPECIFICATION

ACTUAL SIZE OF DO-41 PACKAGE

SERIES GP100 - GP110

DO - 41

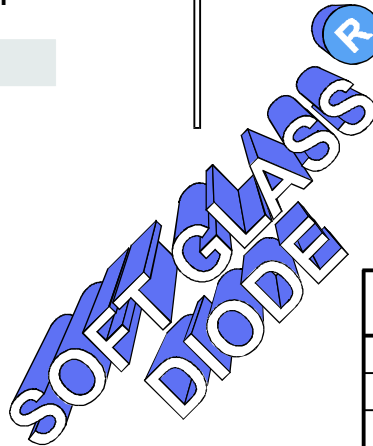
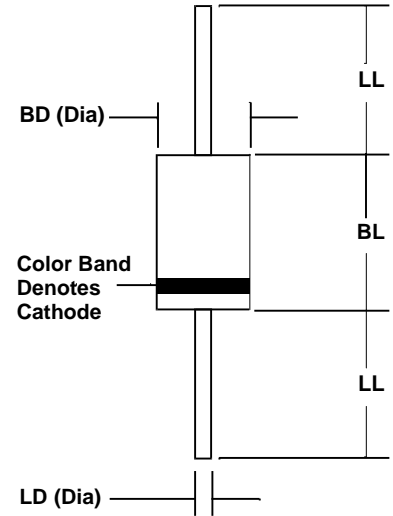

Sym	Minimum		Maximum	
	In	mm	In	mm
BL	0.160	4.1	0.205	5.2
BD	0.103	2.6	0.107	2.7
LL	1.00	25.4		
LD	0.028	0.71	0.034	0.86

MAXIMUM RATINGS & ELECTRICAL CHARACTERISTICS

Ratings at 25 °C ambient temperature unless otherwise specified.
 Single phase, half wave, 60Hz, resistive or inductive load.
 For capacitive loads, derate current by 20%.

PARAMETER (TEST CONDITIONS)	SYMBOL	RATINGS							UNITS
		GP100	GP101	GP102	GP104	GP106	GP108	GP110	
Series Number									
Maximum DC Blocking Voltage	V_{RM}	50	100	200	400	600	800	1000	VOLTS
Maximum RMS Voltage	V_{RMS}	35	70	140	280	420	560	700	
Maximum Peak Recurrent Reverse Voltage	V_{RRM}	50	100	200	400	600	800	1000	
Average Forward Rectified Current @ $T_A = 75^\circ\text{C}$, Lead length = 0.375 in. (9.5 mm)	I_o	1							AMPS
Peak Forward Surge Current (8.3 mSec single half sine wave superimposed on rated load)	I_{FSM}	50							
Maximum Forward Voltage at 1 Amp DC	V_{FM}	1							VOLTS
Maximum Full Cycle Reverse Current @ $T_L = 75^\circ\text{C}$ (Note 1)	$I_{RM(AV)}$	5							μA
Maximum Average DC Reverse Current At Rated DC Blocking Voltage	I_{RM}	0.5 30.0							
Typical Thermal Resistance, Junction to Ambient (Note 1)	$R_{\theta JA}$	30							$^\circ\text{C/W}$
Typical Junction Capacitance (Note 2)	C_J	10							pF
Operating and Storage Temperature Range	T_J, T_{STG}	-65 to +175							$^\circ\text{C}$

NOTES: (1) Lead length = 0.375 in. (9.5 mm)
 (2) Measured at 1MHz & applied reverse voltage of 4 volts

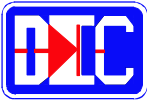

1 AMP HIGH RELIABILITY SILICON DIODES

RATING & CHARACTERISTIC CURVES FOR SERIES GP100 - GP110

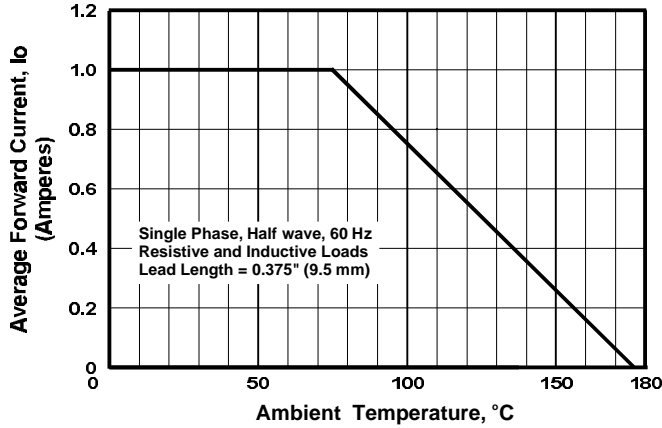

FIGURE 1. FORWARD CURRENT DERATING CURVE

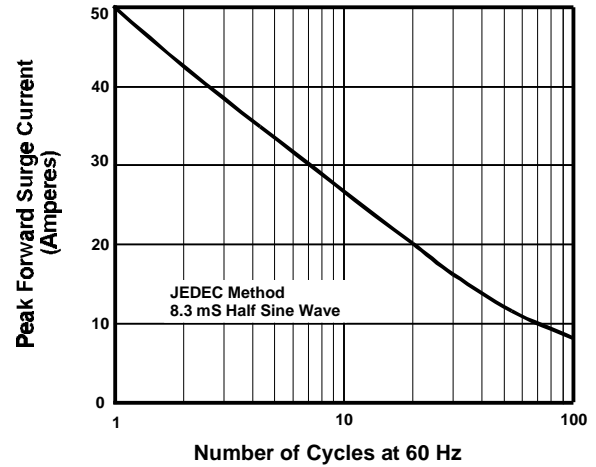

FIGURE 2. MAXIMUM NON-REPETITIVE SURGE CURRENT

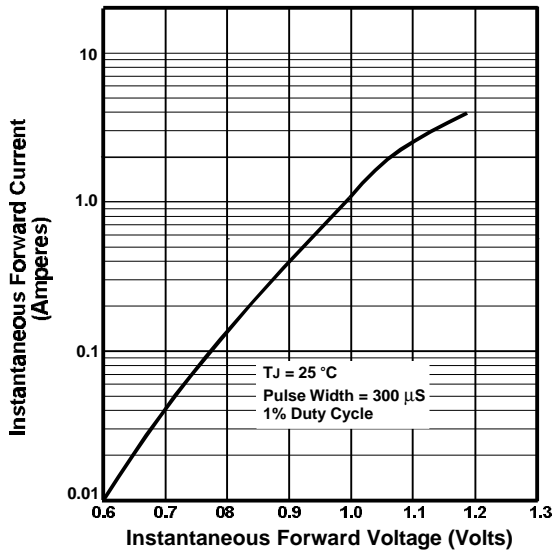

FIGURE 3. TYPICAL FORWARD CHARACTERISTIC PER DIODE

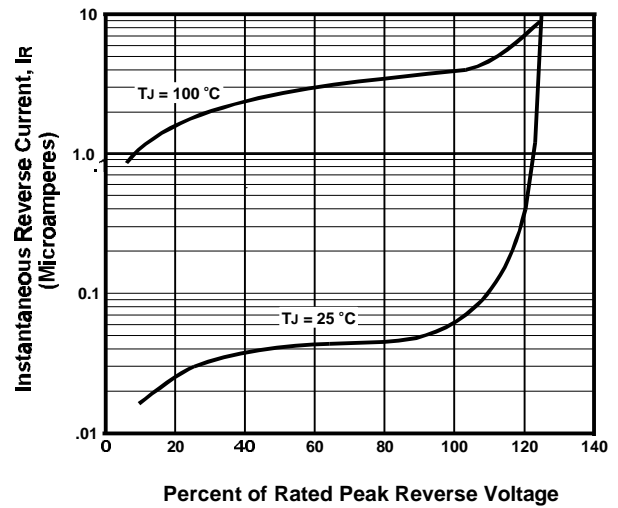

FIGURE 4. TYPICAL REVERSE CHARACTERISTICS

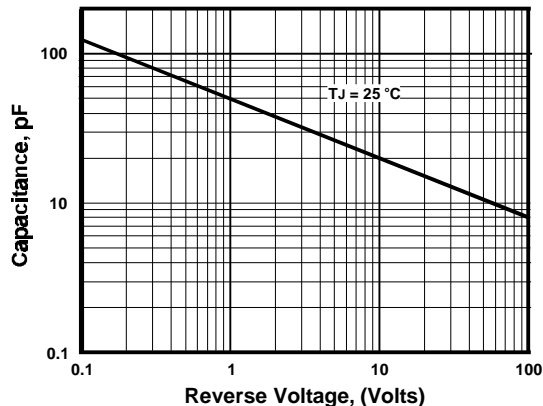

FIGURE 5. TYPICAL JUNCTION CAPACITANCE PER DIODE

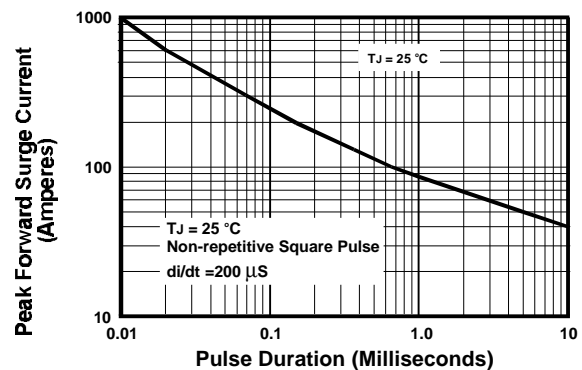
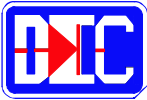

FIGURE 6. PEAK FORWARD SURGE CURRENT



1 AMP SURFACE MOUNT RECTIFIERS

FEATURES

- Low profile package - designed for surface mount applications
- Built-in strain relief, ideal for automated placement
- Glass passivated chip junction
- High temperature soldering: 250 °C/10 seconds at terminals

MECHANICAL DATA

- Case: Molded epoxy, U/L Flammability Rating 94V-0
- Terminals: Solder plated
- Soldering: Per MIL-STD 202 Method 208 guaranteed
- Polarity: Color band identifies cathode terminal
- Weight: 0.004 Ounces (0.115 Grams)

MECHANICAL SPECIFICATION

SERIES S1A - S1M

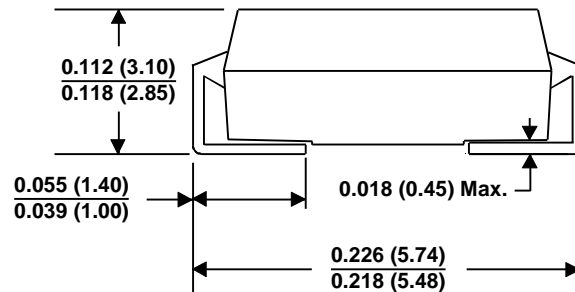
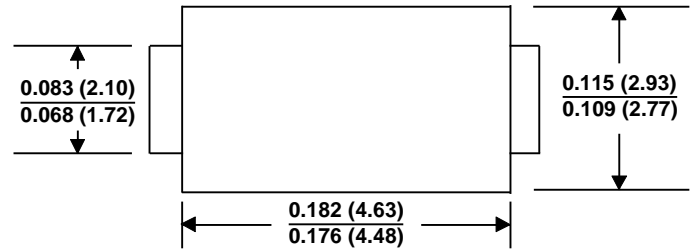

MAXIMUM RATINGS & ELECTRICAL CHARACTERISTICS

Ratings at 25 °C ambient temperature unless otherwise specified.
 Single phase, half wave, 60Hz, resistive or inductive load.
 For capacitive loads, derate current by 20%.

PARAMETER (TEST CONDITIONS)	SYMBOL	RATINGS							UNITS
		S1A	S1B	S1D	S1G	S1J	S1K	S1M	
Series Number									
Maximum Recurrent Peak Reverse Voltage	V _{RRM}	50	100	200	400	600	800	1000	VOLTS
Maximum RMS Voltage	V _{RMS}	35	70	140	280	420	560	700	
Maximum DC Blocking Voltage	V _{DC}	50	100	200	400	600	800	1000	
Maximum Average Forward Rectified Current @ T _L = 110 °C	I _(AV)	1.0							AMPS
Peak Forward Surge Current (8.3mS single half sine wave superimposed on rated load- JEDEC Method) T _L = 110 °C	I _{FSM}	40.0							
Maximum Instantaneous Forward Voltage at 1.0 Amp DC	V _{FM}	1.10							VOLTS
Maximum DC Reverse Current At Rated DC Blocking Voltage @ T _A = 25 °C	I _{RM}	1.0							μA
@ T _A = 125 °C		50.0							
Typical Reverse Recovery Time (Note 1)	T _{RR}	1.8							μS
Typical Junction Capacitance (Note 2)	C _J	12.0							pF
Typical Thermal Resistance (Note 3)	R _{θJL} R _{θJA}	27.0 75.0							°C/W
Operating and Storage Temperature Range	T _J , T _{STG}	-55 to +150							°C

NOTES: (1) Reverse Recovery Test Conditions: I_F = 0.5A, I_R = 1.0A, I_{RR} = 0.25A
 (2) Measured at 1.0 MHz and Applied Reverse Voltage of 4.0 Volts
 (3) Thermal Resistance From Junction to Ambient and Junction to Lead Mounted on 0.2" x 0.2" (5.0mm x 5.0mm) Copper Pad A reas

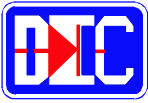

1 AMP SURFACE MOUNT RECTIFIERS

RATING & CHARACTERISTIC CURVES FOR SERIES S1A - S1M

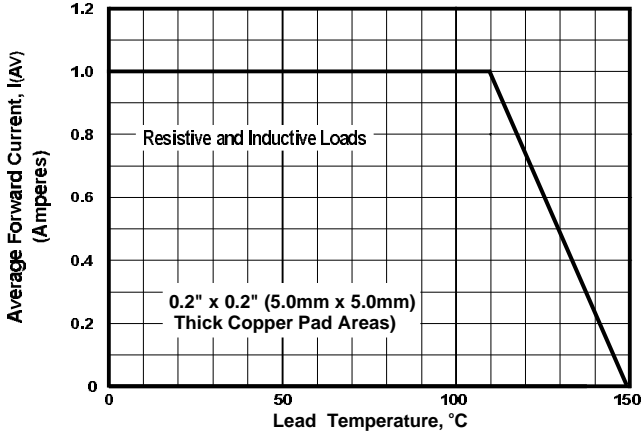

FIGURE 1. FORWARD CURRENT DERATING CURVE

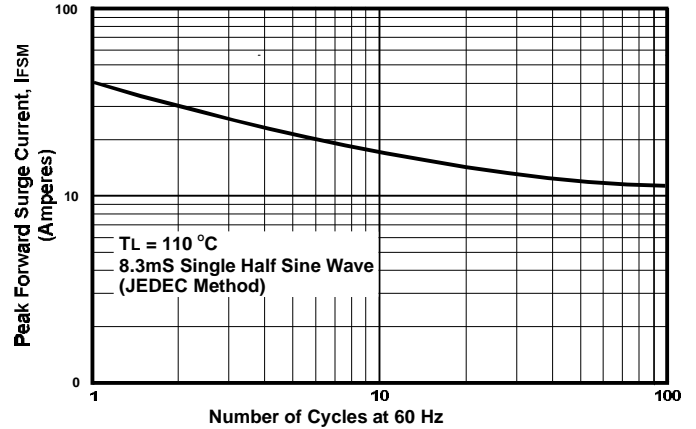

FIGURE 2. MAXIMUM NON-REPETITIVE PEAK FORWARD SURGE CURRENT

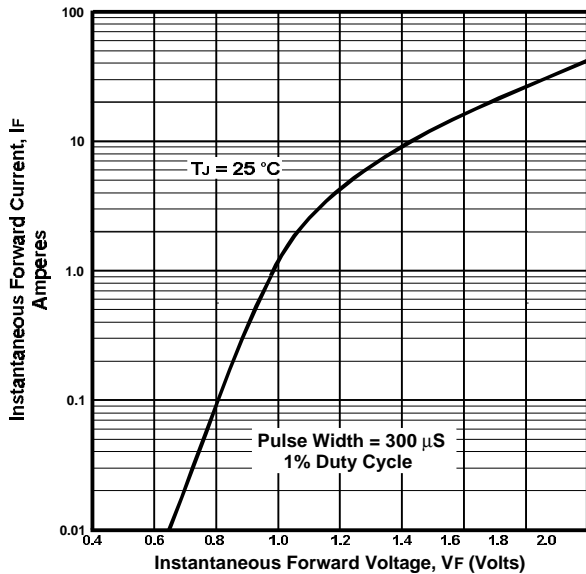

FIGURE 3. TYPICAL INSTANTANEOUS FORWARD CHARACTERISTIC

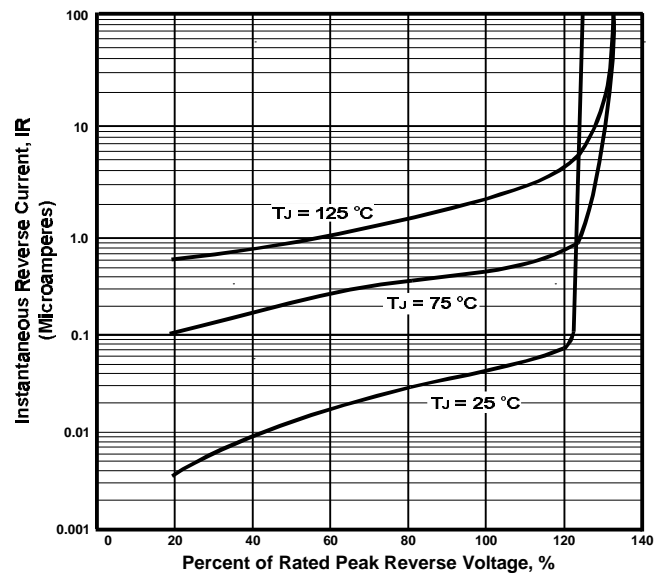

FIGURE 4. TYPICAL REVERSE CHARACTERISTICS

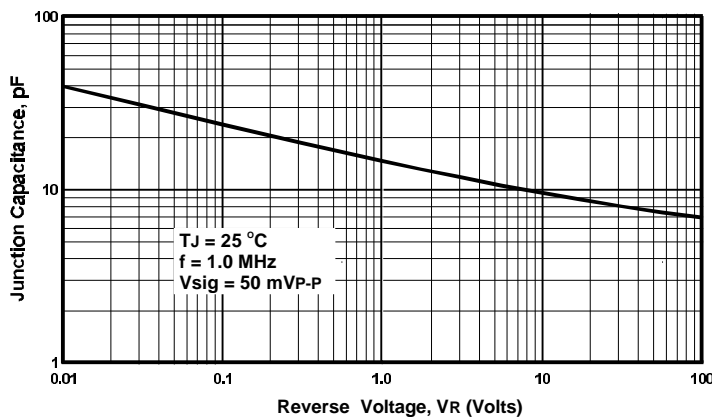

FIGURE 5. TYPICAL JUNCTION CAPACITANCE

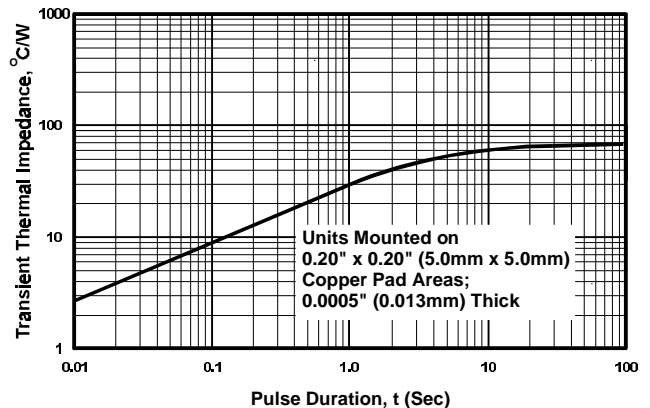
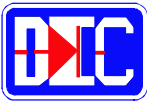

FIGURE 6. TRANSIENT THERMAL IMPEDANCE



1.5 AMP GENERAL PURPOSE SILICON DIODES

FEATURES

- Low cost
- Low leakage
- Low forward voltage drop
- High current capacity
- Easily cleaned with freon, alcohol, chlorothene and similar solvents

MECHANICAL SPECIFICATION

ACTUAL SIZE OF
DO-15 PACKAGE

SERIES 1N5391 - 1N5399

DO - 15

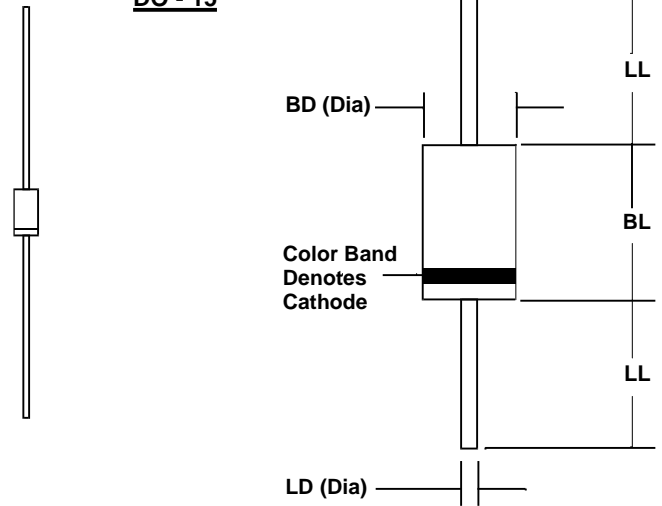

MECHANICAL DATA

- Case: JEDEC DO-15 molded plastic (U/L Flammability Rating 94V-0)
- Terminals: Plated axial leads
- Soldering: Per MIL-STD 202 Method 208 guaranteed
- Polarity: Color band denotes cathode
- Mounting Position: Any
- Weight: 0.01 Ounces (0.4 Grams)

Sym	Minimum		Maximum	
	In	mm	In	mm
BL	0.240	6.01	0.255	6.48
BD	0.130	3.3	0.140	3.6
LL	1.00	25.4		
LD	0.028	0.71	0.034	0.86

MAXIMUM RATINGS & ELECTRICAL CHARACTERISTICS

Ratings at 25 °C ambient temperature unless otherwise specified.
 Single phase, half wave, 60Hz, resistive or inductive load.
 For capacitive loads, derate current by 20%.

PARAMETER (TEST CONDITIONS)	SYMBOL	RATINGS								UNITS
		1N5391	1N5392	1N5393	1N5395	1N5397	1N5398	1N5399		
Series Number										
Maximum DC Blocking Voltage	V _{RM}	50	100	200	400	600	800	1000		VOLTS
Maximum RMS Voltage	V _{RMS}	35	70	140	280	420	560	700		
Maximum Peak Recurrent Reverse Voltage	V _{RRM}	50	100	200	400	600	800	1000		
Average Forward Rectified Current @ T _A = 75 °C, Lead length = 0.375 in. (9.5 mm)	I _O	1.5								AMPS
Peak Forward Surge Current (8.3 mSec single half sine wave superimposed on rated load)	I _{FSM}	60								
Maximum Forward Voltage at 1.5 Amps DC	V _{FM}	1								VOLTS
Maximum Full Cycle Reverse Current @ T _L = 75 °C (Note 1)	I _{RM(AV)}	30								μA
Maximum Average DC Reverse Current @ T _A = 25 °C At Rated DC Blocking Voltage @ T _A = 100 °C	I _{RM}	5								
Typical Thermal Resistance, Junction to Ambient (Note 1)	R _{θJA}	50								°C/W
Typical Junction Capacitance (Note 2)	C _J	30								pF
Operating and Storage Temperature Range	T _J , T _{STG}	-65 to +175								°C

NOTES: (1) Lead length = 0.375 in. (9.5 mm)
 (2) Measured at 1MHz & applied reverse voltage of 4 volts

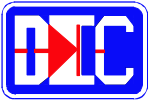

1.5 AMP GENERAL PURPOSE SILICON DIODES

RATING & CHARACTERISTIC CURVES FOR SERIES 1N5391 - 1N5399

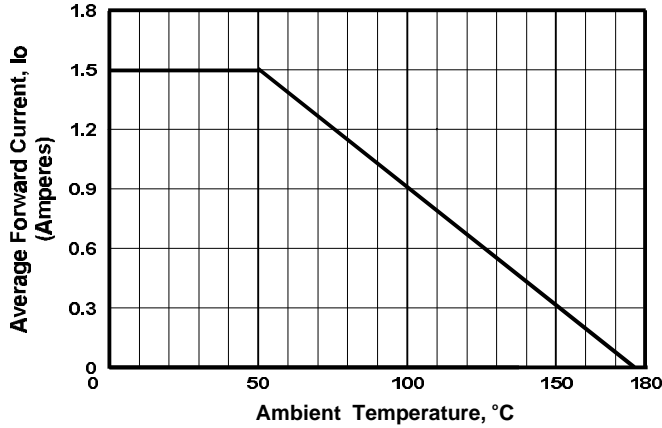

FIGURE 1. FORWARD CURRENT DERATING CURVE

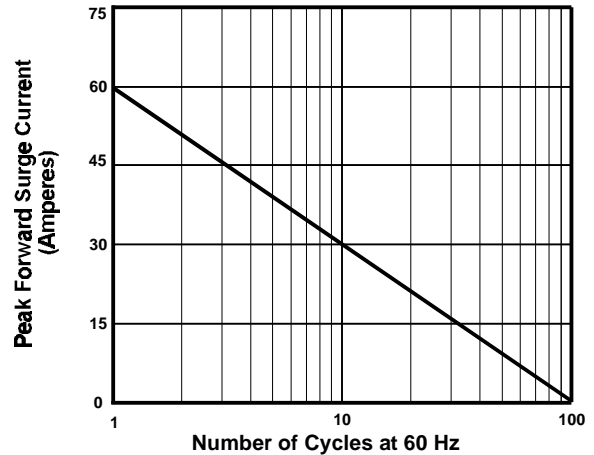

FIGURE 2. MAXIMUM NON-REPETITIVE SURGE CURRENT

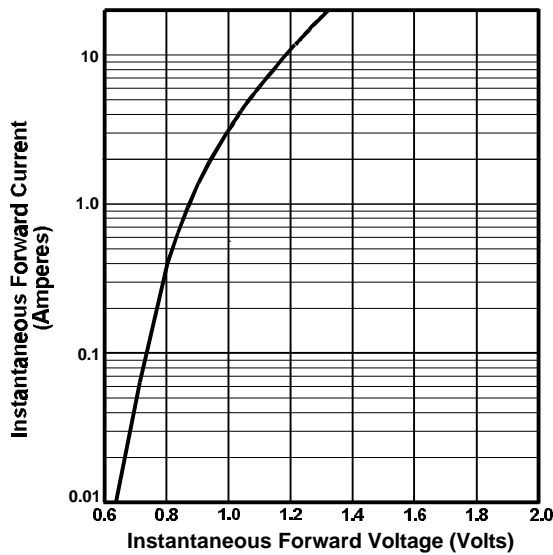

FIGURE 3. TYPICAL FORWARD CHARACTERISTIC PER DIODE

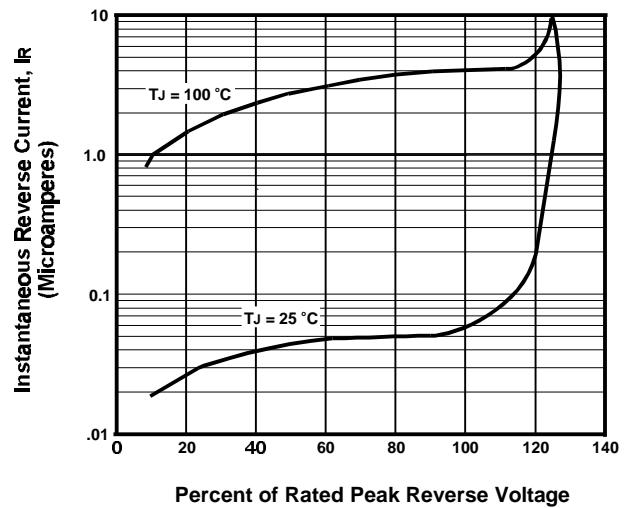

FIGURE 4. TYPICAL REVERSE CHARACTERISTICS

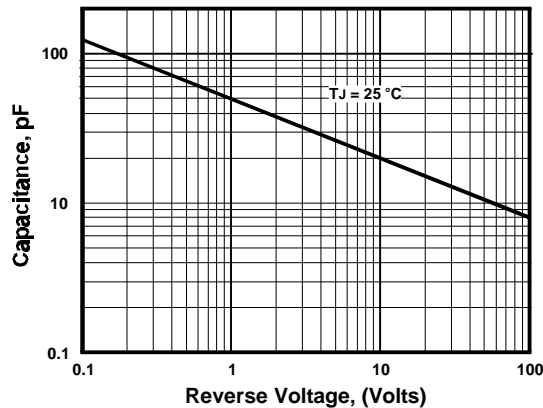
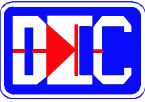

FIGURE 5. TYPICAL JUNCTION CAPACITANCE PER DIODE



2 AMP SOFT GLASS PASSIVATED DIODES

FEATURES

- PROPRIETARY **SOFT GLASS[®]** JUNCTION PASSIVATION FOR SUPERIOR RELIABILITY AND PERFORMANCE
- VOID FREE VACUUM DIE SOLDERING FOR MAXIMUM MECHANICAL STRENGTH AND HEAT DISSIPATION (Solder Voids: Typical $\leq 2\%$, Max. $\leq 10\%$ of Die Area)
- EXTREMELY LOW LEAKAGE AT HIGH TEMPERATURES
- LOW FORWARD VOLTAGE DROP
- 1A at $T_A = 75^\circ\text{C}$ WITH NO THERMAL RUNAWAY

MECHANICAL DATA

- Case: JEDEC DO-41 molded plastic (UL Flammability Rating 94V-0)
- Terminals: Plated axial leads
- Soldering: Per MIL-STD 202 Method 208 guaranteed
- Polarity: Color band denotes cathode
- Mounting Position: Any
- Weight: 0.01 Ounces (0.4 Grams)

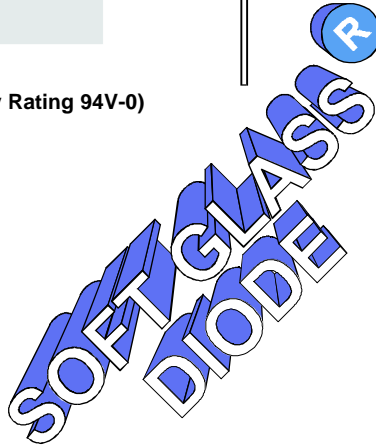

MECHANICAL SPECIFICATION

ACTUAL SIZE OF DO-41 PACKAGE

SERIES GP200 - GP210

DO - 41

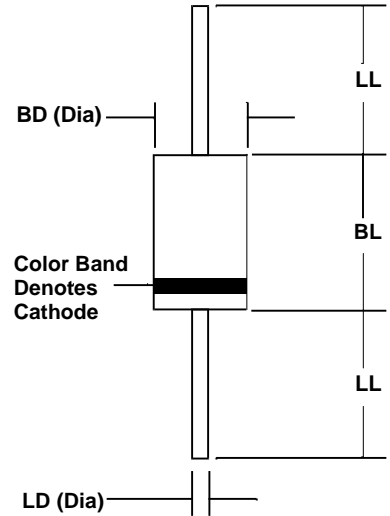

Sym	Minimum		Maximum	
	In	mm	In	mm
BL	0.160	4.1	0.205	5.2
BD	0.103	2.6	0.107	2.7
LL	1.00	25.4		
LD	0.028	0.71	0.034	0.86

MAXIMUM RATINGS & ELECTRICAL CHARACTERISTICS

Ratings at 25 °C ambient temperature unless otherwise specified.
 Single phase, half wave, 60Hz, resistive or inductive load.
 For capacitive loads, derate current by 20%.

PARAMETER (TEST CONDITIONS)	SYMBOL	RATINGS							UNITS
		GP200	GP201	GP202	GP204	GP206	GP208	GP210	
Series Number									
Maximum DC Blocking Voltage	V_{RM}	50	100	200	400	600	800	1000	VOLTS
Maximum RMS Voltage	V_{RMS}	35	70	140	280	420	560	700	
Maximum Peak Recurrent Reverse Voltage	V_{RRM}	50	100	200	400	600	800	1000	
Average Forward Rectified Current @ $T_A = 75^\circ\text{C}$, Lead length = 0.375 in. (9.5 mm)	I_o	2							AMPS
Peak Forward Surge Current (8.3 mSec single half sine wave superimposed on rated load)	I_{FSM}	70							
Maximum Forward Voltage at 2 Amps DC	V_{FM}	1.1							VOLTS
Maximum Reverse Recovery Time ($I_F=0.5A$, $I_R=1A$, $I_{RR}=0.25A$)	T_{RR}	30							μA
Maximum Average DC Reverse Current @ $T_A = 25^\circ\text{C}$ At Rated DC Blocking Voltage @ $T_A = 100^\circ\text{C}$	I_{RM}	5 50							
Typical Junction Capacitance (Note 1)	C_J	40							pF
Operating and Storage Temperature Range	T_J, T_{STG}	-65 to +175							$^\circ\text{C}$

NOTES: (1) Measured at 1MHz & applied reverse voltage of 4 volts
 (2) 300 nS available - consult factory

4.97 fppd200

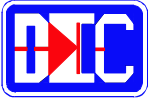

2 AMP SOFT GLASS PASSIVATED SILICON DIODES

RATING & CHARACTERISTIC CURVES FOR SERIES GP200 - GP210

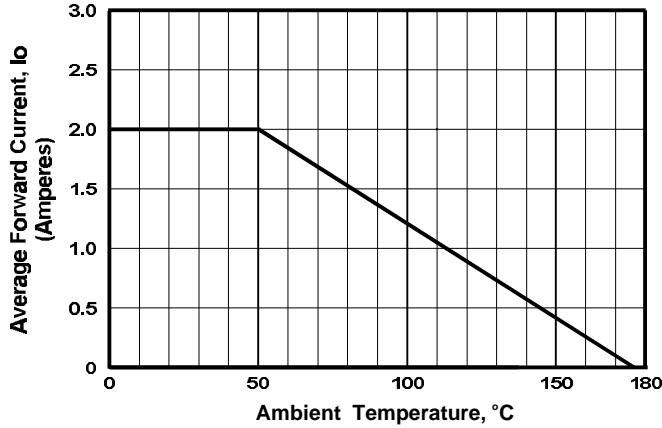

FIGURE 1. FORWARD CURRENT DERATING CURVE

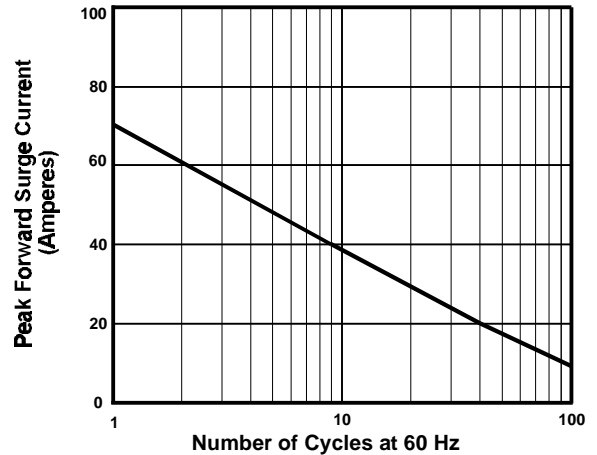

FIGURE 2. MAXIMUM NON-REPETITIVE SURGE CURRENT

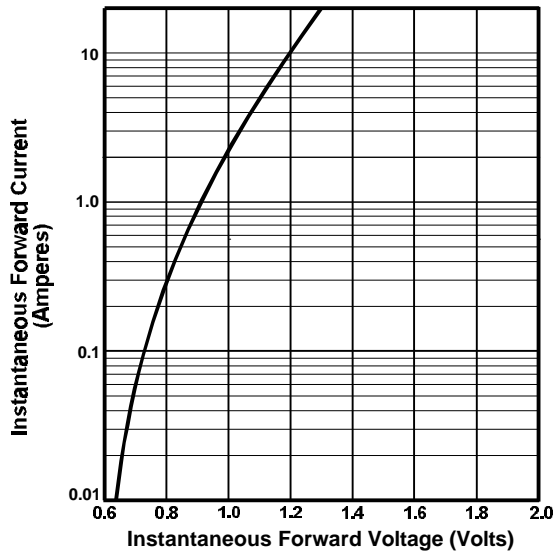

FIGURE 3. TYPICAL FORWARD CHARACTERISTIC PER DIODE

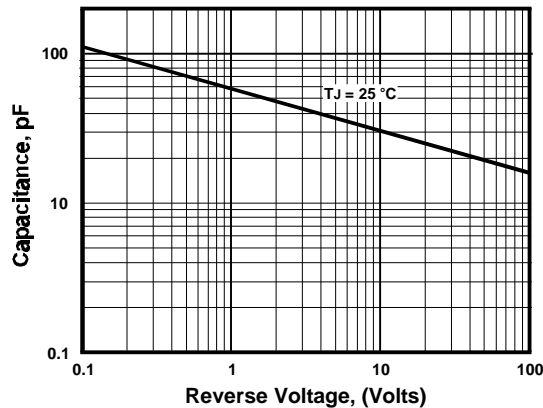
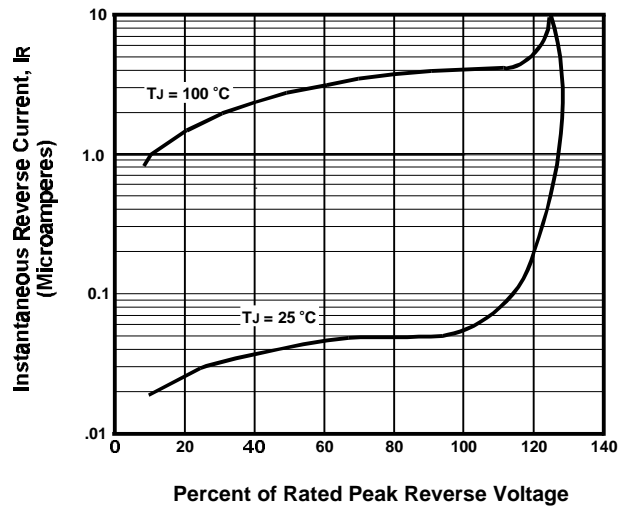
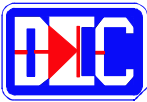

FIGURE 5. TYPICAL JUNCTION CAPACITANCE PER DIODE



3 AMP GENERAL PURPOSE SILICON DIODES

FEATURES

- Low cost
- Low leakage
- Low forward voltage drop
- High current capacity
- Easily cleaned with freon, alcohol, chlorothene and similar solvents

MECHANICAL SPECIFICATION

ACTUAL SIZE OF
DO-27 PACKAGE

SERIES 1N5400 - 1N5408

DO - 27

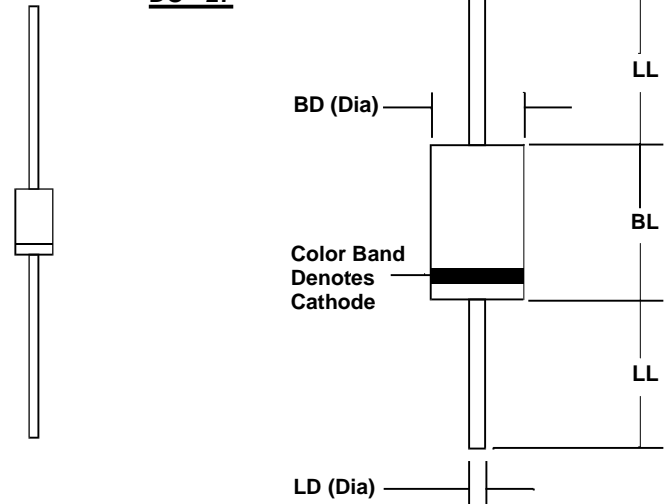

MECHANICAL DATA

- Case: JEDEC DO-27 molded plastic (U/L Flammability Rating 94V-0)
- Terminals: Plated axial leads
- Soldering: Per MIL-STD 202 Method 208 guaranteed
- Polarity: Color band denotes cathode
- Mounting Position: Any
- Weight: 0.02 Ounces (0.7 Grams)

Sym	Minimum		Maximum	
	In	mm	In	mm
BL			0.365	9.28
BD			0.205	5.2
LL	1.00	25.4		
LD	0.048	1.2	0.052	1.3

MAXIMUM RATINGS & ELECTRICAL CHARACTERISTICS

Ratings at 25 °C ambient temperature unless otherwise specified.
 Single phase, half wave, 60Hz, resistive or inductive load.
 For capacitive loads, derate current by 20%.

PARAMETER (TEST CONDITIONS)	SYMBOL	RATINGS								UNITS
		1N5400	1N5401	1N5402	1N5404	1N5406	1N5407	1N5408		
Series Number										
Maximum DC Blocking Voltage	V _{RM}	50	100	200	400	600	800	1000		VOLTS
Maximum RMS Voltage	V _{RMS}	35	70	140	280	420	560	700		
Maximum Peak Recurrent Reverse Voltage	V _{RRM}	50	100	200	400	600	800	1000		
Average Forward Rectified Current @ T _A = 75 °C Lead length = 0.375 in. (9.5 mm)	I _O	3								AMPS
Peak Forward Surge Current (8.3 mSec single half sine wave superimposed on rated load)	I _{FSM}	200								
Maximum Forward Voltage at 3 Amps DC	V _{FM}	1								VOLTS
Maximum Full Cycle Reverse Current @ T _L = 75 °C (Note 1)	I _{RM(AV)}	30								μA
Maximum Average DC Reverse Current At Rated DC Blocking Voltage	I _{RM}	5								
Typical Thermal Resistance, Junction to Ambient (Note 1)	R _{θJA}	18								°C/W
Typical Junction Capacitance (Note 2)	C _J	70								pF
Operating and Storage Temperature Range	T _J , T _{STG}	-65 to +175								°C

NOTES: (1) Lead length = 0.375 in. (9.5 mm)
 (2) Measured at 1MHz & applied reverse voltage of 4 volts

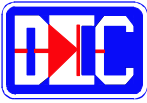

3 AMP GENERAL PURPOSE SILICON DIODES

RATING & CHARACTERISTIC CURVES FOR SERIES 1N5400 - 1N5408

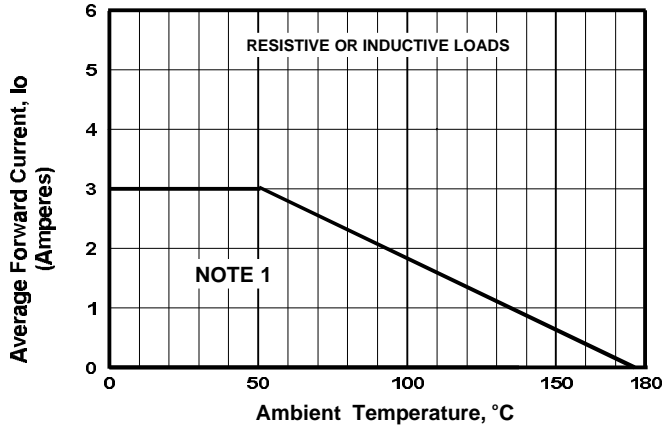

FIGURE 1. FORWARD CURRENT DERATING CURVE

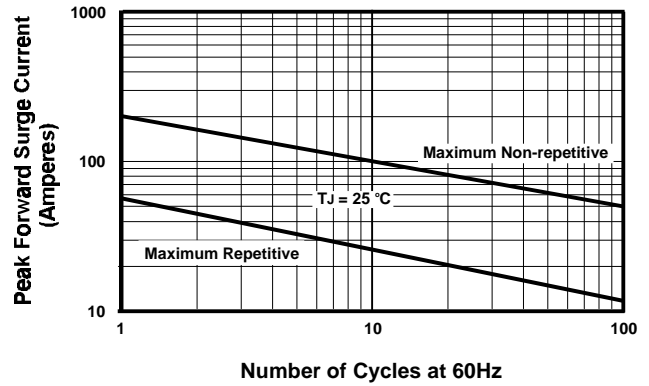

FIGURE 2. FORWARD SURGE CURRENT

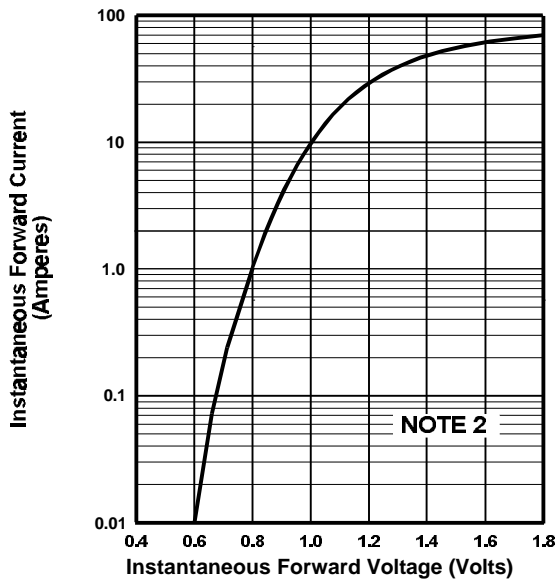

FIGURE 3. TYPICAL FORWARD CHARACTERISTICS

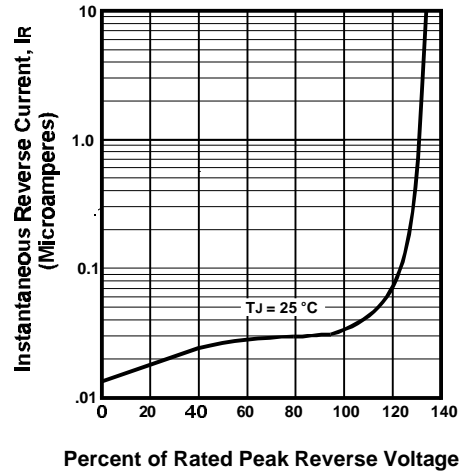

FIGURE 4. TYPICAL REVERSE CHARACTERISTICS

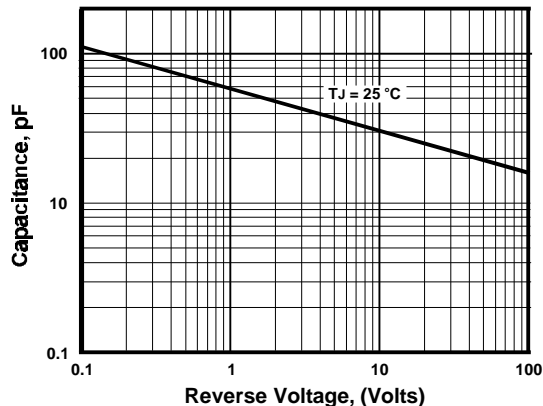
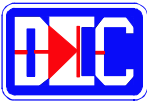

FIGURE 5. TYPICAL JUNCTION CAPACITANCE

NOTES

- (1) Single Phase, Half Wave, 60 Hz; Lead Length = 0.375" (9.5mm)
- (2) $T_J = 25^\circ\text{C}$, Pulse Width = 300 μSec , 1.0% Duty Cycle



3 AMP SOFT GLASS PASSIVATED SILICON DIODES

FEATURES

- PROPRIETARY **SOFT GLASS[®]** JUNCTION PASSIVATION FOR SUPERIOR RELIABILITY AND PERFORMANCE
- VOID FREE VACUUM DIE SOLDERING FOR MAXIMUM MECHANICAL STRENGTH AND HEAT DISSIPATION (Solder Voids: Typical $\leq 2\%$, Max. $\leq 10\%$ of Die Area)
- EXTREMELY LOW LEAKAGE AT HIGH TEMPERATURES
- LOW FORWARD VOLTAGE DROP
- 3A at $T_A = 75^\circ\text{C}$ WITH NO THERMAL RUNAWAY

MECHANICAL DATA

- Case: JEDEC DO-27 molded plastic (UL Flammability Rating 94V-0)
- Terminals: Plated axial leads
- Soldering: Per MIL-STD 202 Method 208 guaranteed
- Polarity: Color band denotes cathode
- Mounting Position: Any
- Weight: 0.02 Ounces (0.7 Grams)

SOFT GLASS[®] DIODE

MECHANICAL SPECIFICATION

ACTUAL SIZE OF DO-27 PACKAGE

SERIES 1N5400G - 1N5408G

DO - 27

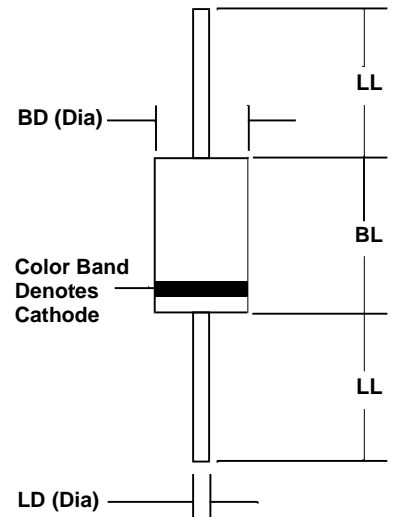

Sym	Minimum		Maximum	
	In	mm	In	mm
BL			0.365	9.28
BD			0.205	5.2
LL	1.00	25.4		
LD	0.048	1.2	0.052	1.3

MAXIMUM RATINGS & ELECTRICAL CHARACTERISTICS

Ratings at 25 °C ambient temperature unless otherwise specified.
 Single phase, half wave, 60Hz, resistive or inductive load.
 For capacitive loads, derate current by 20%.

PARAMETER (TEST CONDITIONS)	SYMBOL	RATINGS							UNITS
		1N 5400G	1N 5401G	1N 5402G	1N 5404G	1N 5406G	1N 5407G	1N 5408G	
Maximum DC Blocking Voltage	V_{RM}	50	100	200	400	600	800	1000	VOLTS
Maximum RMS Voltage	V_{RMS}	35	70	140	280	420	560	700	
Maximum Peak Recurrent Reverse Voltage	V_{RRM}	50	100	200	400	600	800	1000	
Average Forward Rectified Current @ $T_A = 75^\circ\text{C}$ (Lead length = 0.375 in. (9.5 mm))	I_o	3							AMPS
Peak Forward Surge Current (8.3 mSec single half sine wave superimposed on rated load)	I_{FSM}	200							
Maximum Forward Voltage at 3 Amps DC	V_{FM}	1							VOLTS
Maximum Full Cycle Reverse Current @ $T_L = 75^\circ\text{C}$ (Note 1)	$I_{RM(AV)}$	20							μA
Maximum Average DC Reverse Current At Rated DC Blocking Voltage	I_{RM}	50							
Typical Thermal Resistance, Junction to Ambient (Note 1)	$R_{\theta JA}$	18							$^\circ\text{C/W}$
Typical Junction Capacitance (Note 2)	C_J	70							pF
Operating and Storage Temperature Range	T_J, T_{STG}	-65 to +175							$^\circ\text{C}$

NOTES: (1) Lead length = 0.375 in. (9.5 mm)
 (2) Measured at 1MHz & applied reverse voltage of 4 volts

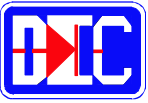

3 AMP SOFT GLASS PASSIVATED SILICON DIODES

RATING & CHARACTERISTIC CURVES FOR SERIES 1N5400G - 1N5408G

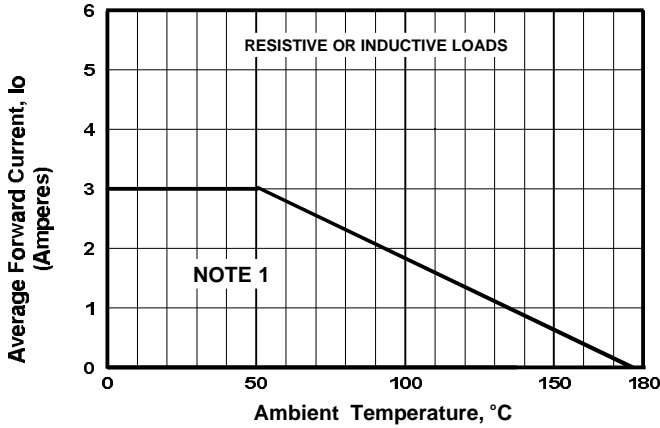

FIGURE 1. FORWARD CURRENT DERATING CURVE

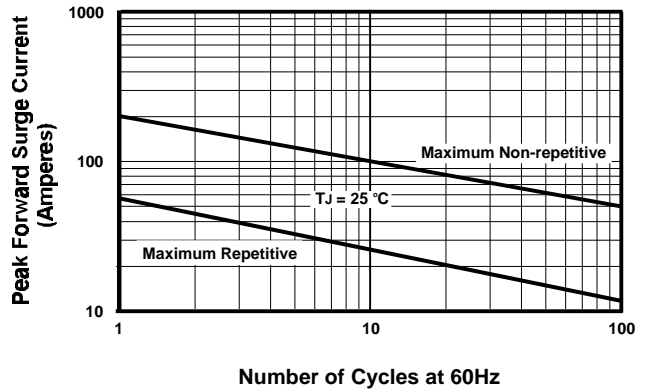

FIGURE 2. FORWARD SURGE CURRENT

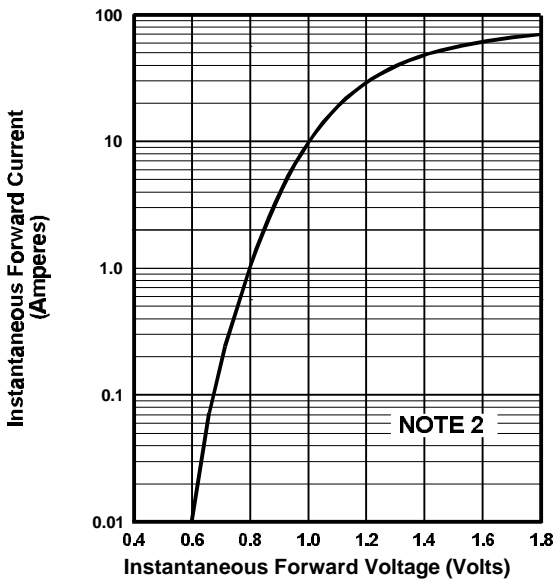

FIGURE 3. TYPICAL FORWARD CHARACTERISTICS

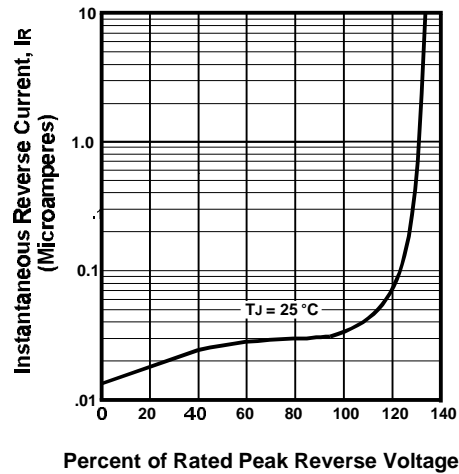

FIGURE 4. TYPICAL REVERSE CHARACTERISTICS

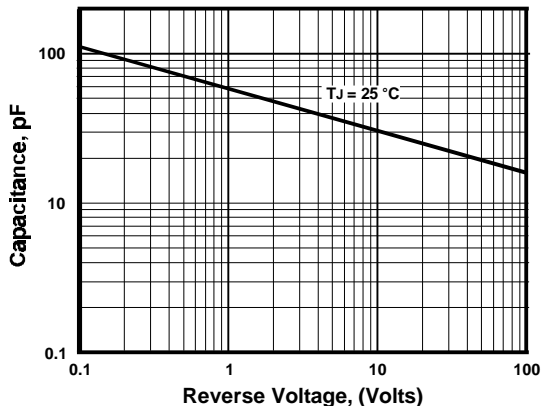
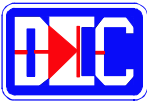

FIGURE 5. TYPICAL JUNCTION CAPACITANCE

NOTES

- (1) Single Phase, Half Wave, 60 Hz; Lead Length = 0.375" (9.5mm)
- (2) T_J = 25 °C, Pulse Width = 300 μSec, 1.0% Duty Cycle



4 AMP HIGH RELIABILITY SOFT GLASS PASSIVATED SILICON DIODES

FEATURES

- PROPRIETARY **SOFT GLASS[®]** JUNCTION PASSIVATION FOR SUPERIOR RELIABILITY AND PERFORMANCE
- VOID FREE VACUUM DIE SOLDERING FOR MAXIMUM MECHANICAL STRENGTH AND HEAT DISSIPATION (Solder Voids: Typical $\leq 2\%$, Max. $\leq 10\%$ of Die Area)
- EXTREMELY LOW LEAKAGE AT HIGH TEMPERATURES
- LOW FORWARD VOLTAGE DROP
- 4A at $T_A = 75^\circ\text{C}$ WITH NO THERMAL RUNAWAY

MECHANICAL DATA

- Case: JEDEC DO-27 molded silica glass (U/L Flammability Rating 94V-0)
- Terminals: Plated axial leads
- Soldering: Per MIL-STD 202 Method 208 guaranteed
- Polarity: Color band denotes cathode
- Mounting Position: Any
- Weight: 0.02 Ounces (0.7 Grams)

MECHANICAL SPECIFICATION

ACTUAL SIZE OF DO-27 PACKAGE

SERIES GP400 - GP410

DO - 27

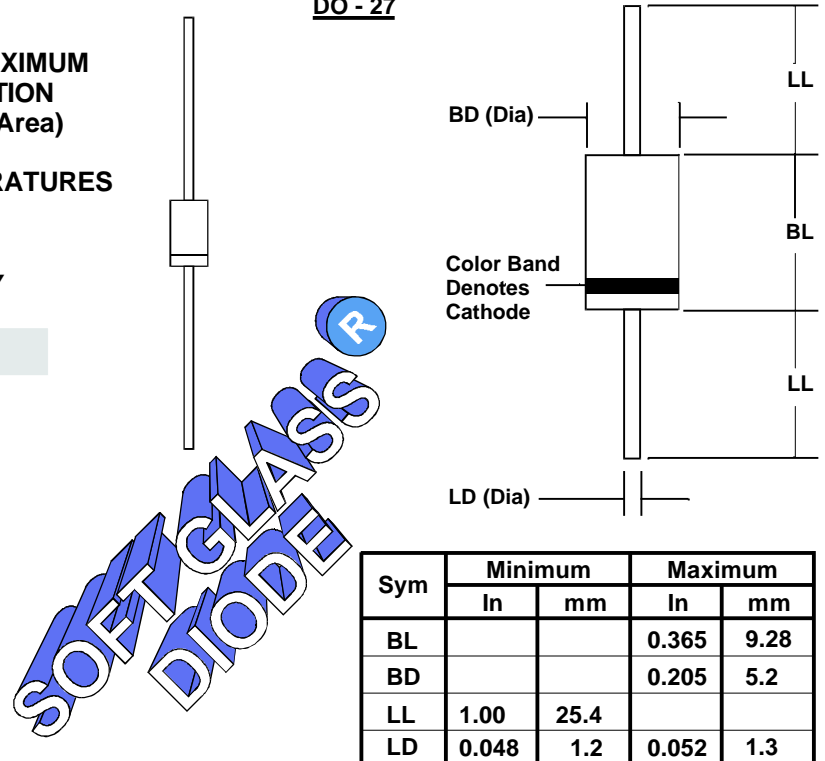

Sym	Minimum		Maximum	
	In	mm	In	mm
BL			0.365	9.28
BD			0.205	5.2
LL	1.00	25.4		
LD	0.048	1.2	0.052	1.3

MAXIMUM RATINGS & ELECTRICAL CHARACTERISTICS

Ratings at 25 °C ambient temperature unless otherwise specified.
 Single phase, half wave, 60Hz, resistive or inductive load.
 For capacitive loads, derate current by 20%.

PARAMETER (TEST CONDITIONS)	SYMBOL	RATINGS							UNITS
		GP400	GP401	GP402	GP404	GP406	GP408	GP410	
Series Number									
Maximum DC Blocking Voltage	V_{RM}	50	100	200	400	600	800	1000	VOLTS
Maximum RMS Voltage	V_{RMS}	35	70	140	280	420	560	700	
Maximum Peak Recurrent Reverse Voltage	V_{RRM}	50	100	200	400	600	800	1000	
Average Forward Rectified Current @ $T_A = 75^\circ\text{C}$, Lead length = 0.375 in. (9.5 mm)	I_o	4							AMPS
Peak Forward Surge Current (8.3 mSec single half sine wave superimposed on rated load)	I_{FSM}	200							
Maximum Forward Voltage at 4 Amps DC	V_{FM}	1							VOLTS
Maximum Full Cycle Reverse Current @ $T_L = 75^\circ\text{C}$ (Note 1)	$I_{RM(AV)}$	20							μA
Maximum Average DC Reverse Current @ $T_A = 25^\circ\text{C}$ At Rated DC Blocking Voltage @ $T_A = 100^\circ\text{C}$	I_{RM}	50							
Typical Thermal Resistance, Junction to Ambient (Note 1)	$R_{\theta JA}$	18							$^\circ\text{C/W}$
Typical Junction Capacitance (Note 2)	C_J	70							pF
Operating and Storage Temperature Range	T_J, T_{STG}	-65 to +175							$^\circ\text{C}$

NOTES: (1) Lead length = 0.375 in. (9.5 mm)
 (2) Measured at 1MHz & applied reverse voltage of 4 volts

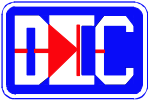

4 AMP HIGH RELIABILITY SOFT GLASS PASSIVATED SILICON DIODES

RATING & CHARACTERISTIC CURVES FOR SERIES GP400 - GP410

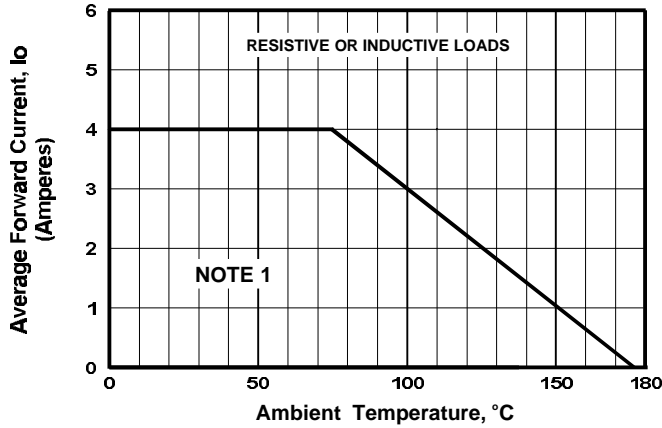

FIGURE 1. FORWARD CURRENT DERATING CURVE

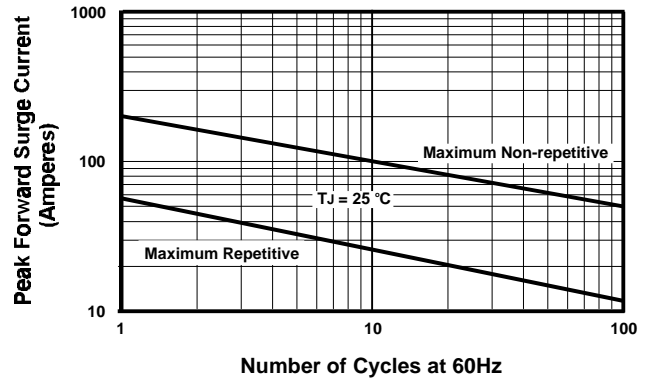

FIGURE 2. FORWARD SURGE CURRENT

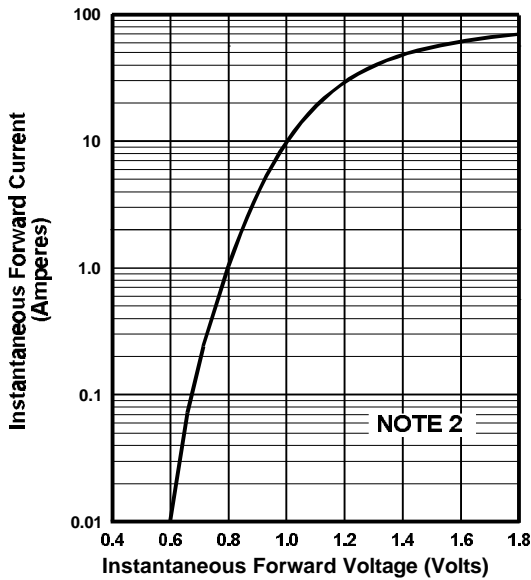

FIGURE 3. TYPICAL FORWARD CHARACTERISTICS

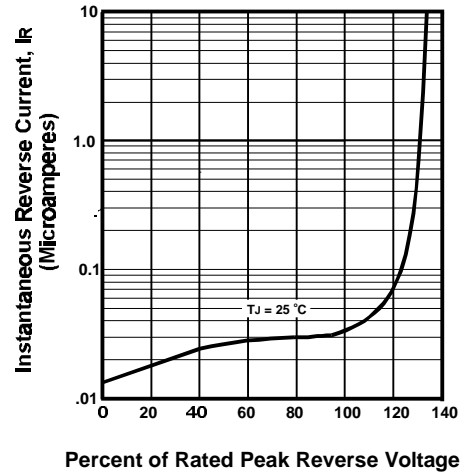

FIGURE 4. TYPICAL REVERSE CHARACTERISTICS

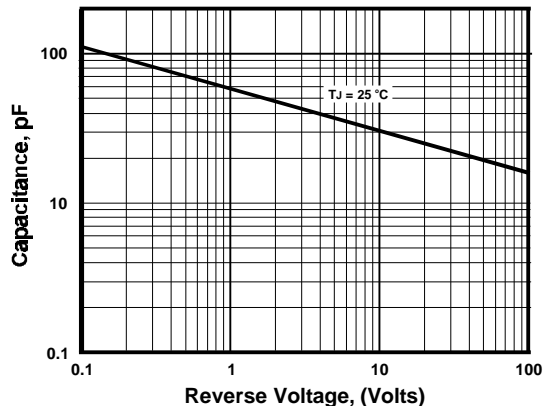
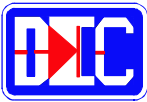

FIGURE 5. TYPICAL JUNCTION CAPACITANCE

NOTES

- (1) Single Phase, Half Wave, 60 Hz; Lead Length = 0.375" (9.5mm)
- (2) T_J = 25 °C, Pulse Width = 300 μSec, 1.0% Duty Cycle



6 AMP GENERAL PURPOSE SILICON DIODES

FEATURES

- Low cost
- Low leakage
- Low forward voltage drop
- High current capacity
- Easily cleaned with freon, alcohol, chloroethene and similar solvents

MECHANICAL DATA

- Case: Molded epoxy (U/L Flammability Rating 94V-0)
- Terminals: Plated axial leads
- Soldering: Per MIL-STD 202 Method 208 guaranteed
- Polarity: Color band denotes cathode
- Mounting Position: Any
- Weight: 0.07 Ounces (2.1 Grams)

MECHANICAL SPECIFICATION

ACTUAL SIZE OF
GP600 PACKAGE

SERIES GP600 - GP610

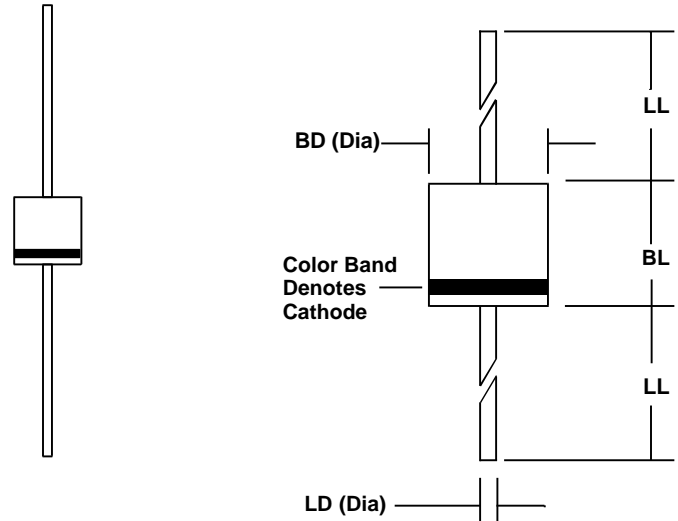

Sym	Minimum		Maximum	
	In	mm	In	mm
BL	0.340	8.6	0.360	9.1
BD	0.340	8.6	0.360	9.1
LL	1.00	25.4		
LD	0.048	1.2	0.052	1.3

MAXIMUM RATINGS & ELECTRICAL CHARACTERISTICS

Ratings at 25 °C ambient temperature unless otherwise specified.
 Single phase, half wave, 60Hz, resistive or inductive load.
 For capacitive loads, derate current by 20%.

PARAMETER (TEST CONDITIONS)	SYMBOL	RATINGS							UNITS
		GP600	GP601	GP602	GP604	GP606	GP608	GP610	
Series Number									
Maximum DC Blocking Voltage	V _{RM}	50	100	200	400	600	800	1000	VOLTS
Maximum RMS Voltage	V _{RMS}	35	70	140	280	420	560	700	
Maximum Peak Recurrent Reverse Voltage	V _{RRM}	50	100	200	400	600	800	1000	
Average Forward Rectified Current @ T _A = 60 °C, Lead length = 0.375 in. (9.5 mm)	I _O	6							AMPS
Peak Forward Surge Current (8.3 mSec single half sine wave superimposed on rated load)	I _{FSM}	400							
Maximum Forward Voltage at 6 Amps DC	V _{FM}	1							VOLTS
Maximum Full Cycle Reverse Current @ T _L = 75 °C (Note 1)	I _{RM(AV)}	25							μA
Maximum Average DC Reverse Current @ T _A = 25 °C	I _{RM}	10							
At Rated DC Blocking Voltage @ T _A = 100 °C		100							
Typical Thermal Resistance, Junction to Ambient (Note 1)	R _{θJA}	10							°C/W
Typical Junction Capacitance (Note 2)	C _J	100							pF
Operating and Storage Temperature Range	T _J , T _{STG}	-65 to +175							°C

NOTES: (1) Lead length = 0.375 in. (9.5 mm)
 (2) Measured at 1MHz & applied reverse voltage of 4 volts

01.00 fgpdp601

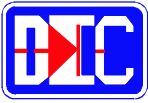

6 AMP GENERAL PURPOSE SILICON DIODES

RATING & CHARACTERISTIC CURVES FOR SERIES GP600 - GP610

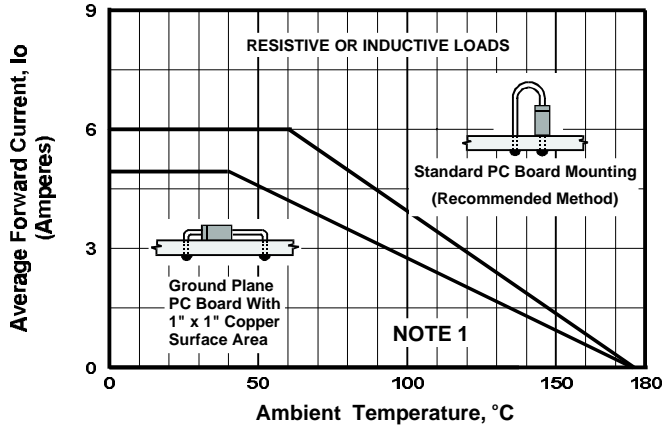

FIGURE 1. FORWARD CURRENT DERATING CURVE

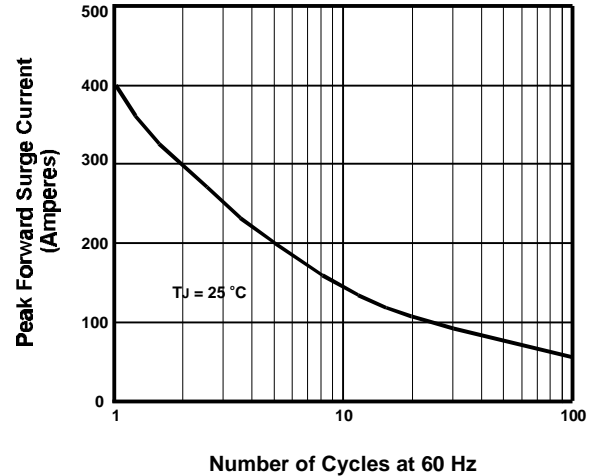

FIGURE 2. MAXIMUM NON-REPETITIVE SURGE CURRENT

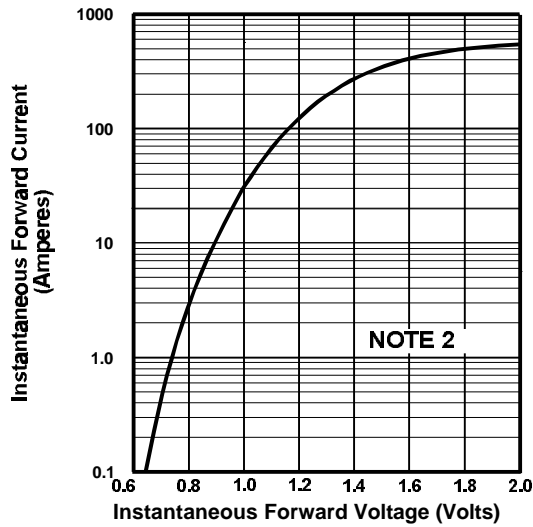

FIGURE 3. TYPICAL FORWARD CHARACTERISTICS

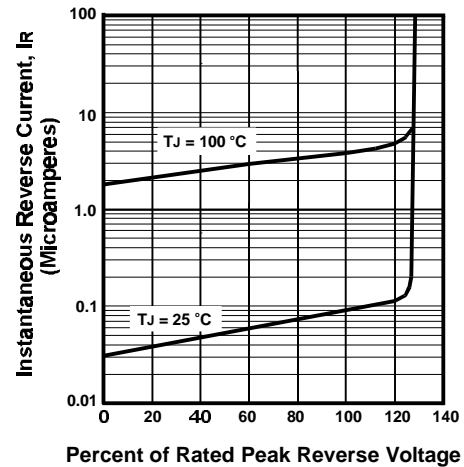

FIGURE 4. TYPICAL REVERSE CHARACTERISTICS

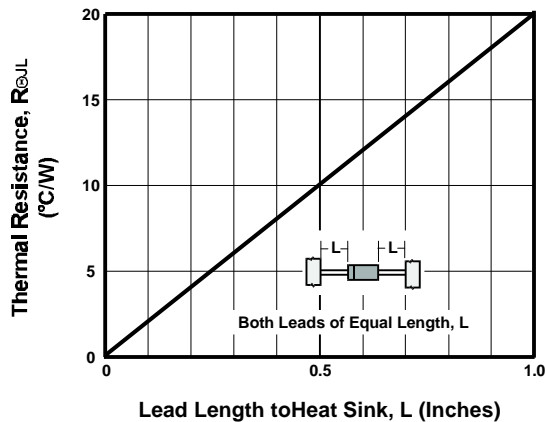
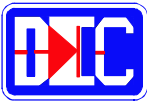

FIGURE 5. TYPICAL THERMAL RESISTANCE

NOTES

- (1) Single Phase, Half Wave, 60 Hz
- (2) $T_J = 25^\circ\text{C}$, Pulse Width = 300 μSec , 1.0% Duty Cycle



1N4148 MINIATURE ULTRA FAST SWITCHING DIODE

FEATURES

- Hermetically sealed glass package
- Low cost
- Super fast recovery time
- Low leakage
- Low forward voltage drop
- High current capability

MECHANICAL SPECIFICATION

ACTUAL SIZE OF
DO-35 PACKAGE

1N4148

DO-35

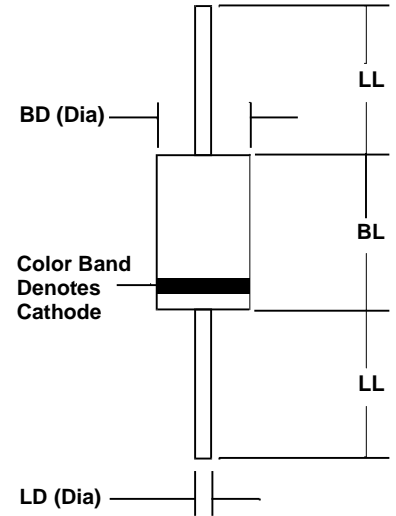

MECHANICAL DATA

- Case: JEDEC DO-35 molded glass (U/L Flammability Rating 94V-0)
- Terminals: Plated axial leads
- Soldering: Per MIL-STD 202 Method 208 guaranteed
- Polarity: Color band denotes cathode
- Mounting Position: Any
- Weight: 0.005 Ounces (0.14 Grams)

Sym	Minimum		Maximum	
	In	mm	In	mm
BL	0.142	3.6	0.150	3.81
BD	0.07	1.78	0.072	1.83
LL	1.00	25.4		
LD	0.02	0.52	0.03	0.8

MAXIMUM RATINGS & ELECTRICAL CHARACTERISTICS

Ratings at 25 °C ambient temperature unless otherwise specified.
 Single phase, half wave, 60Hz, resistive or inductive load.
 For capacitive loads, derate current by 20%.

PARAMETER (TEST CONDITIONS)	SYMBOL	RATINGS	UNITS
Series Number		1N4148	
Breakdown Voltage at $I_R = 5 \mu A$	V_B	75	VOLTS
Breakdown Voltage at $I_R = 100 \mu A$	V_B	100	
Maximum Peak Recurrent Reverse Voltage	V_{RRM}	75	
Average Forward Rectified Current @ $T_A = 50^\circ C$, Lead length = 0.375 in. (9.5 mm)	I_o	150	mA
Peak Forward Surge Current	I_{FSM}	1 4	AMPS
Maximum Forward Voltage at 10 mA DC	V_{FM}	1	VOLTS
Maximum Power Dissipation	P_{FM}	500	mW
Maximum Average DC Reverse Current	I_{RM}	25 5	nA μA
Maximum Reverse Recovery Time (Note 1)	T_{RR}	4	nS
Typical Junction Capacitance (Note 2)	C_J	4	pF
Operating and Storage Temperature Range	T_J, T_{STG}	-65 to +175	$^\circ C$

NOTES: (1) Measured at $I_R = 10 \text{ mA}$, $V_R = 6V$, $R_L = 100\Omega$; recover to 1 mA
 (2) Measured at 1MHz & applied reverse voltage of 0 volts DC



1N4148 MINIATURE ULTRA FAST SWITCHING DIODE

RATING & CHARACTERISTIC CURVES FOR THE 1N4148

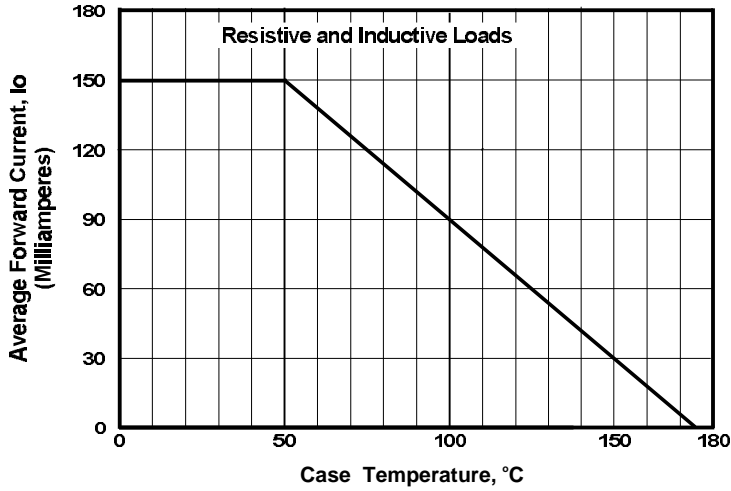

FIGURE 1. FORWARD CURRENT DERATING CURVE

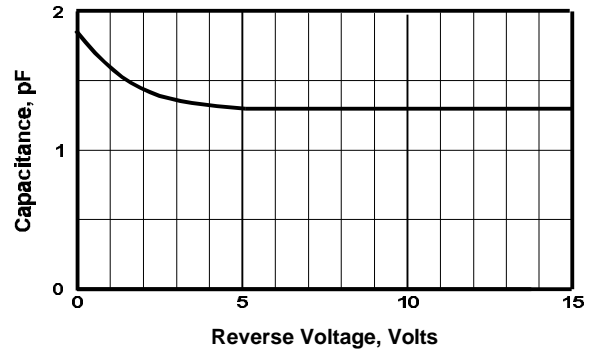

FIGURE 2. TYPICAL JUNCTION CAPACITANCE

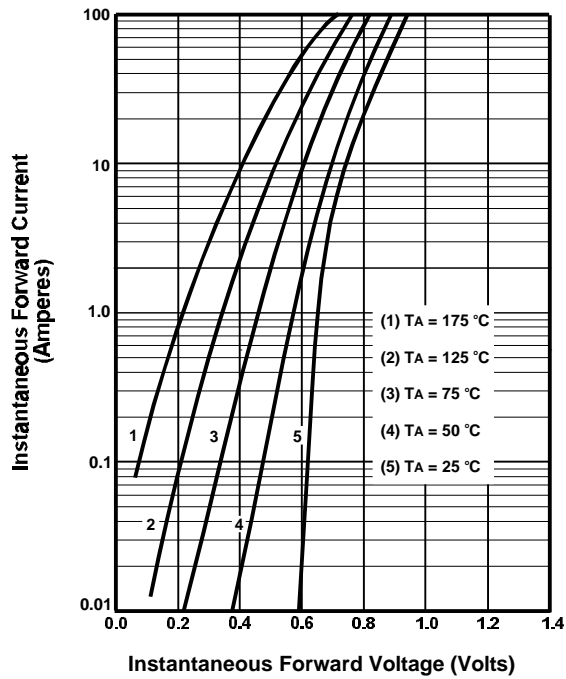

FIGURE 3. TYPICAL FORWARD CHARACTERISTIC PER DIODE

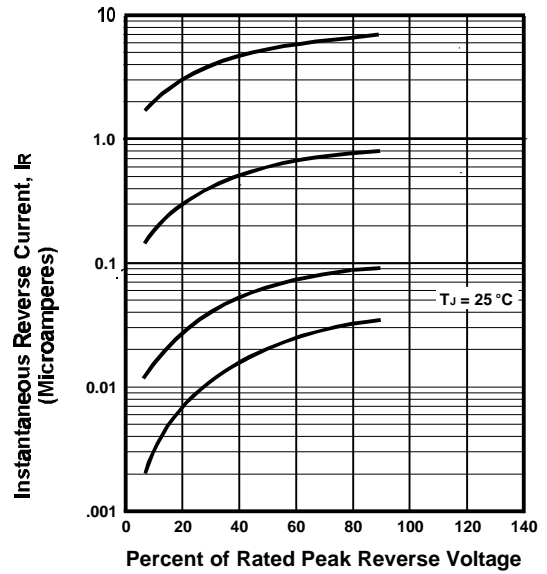
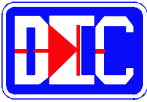

FIGURE 4. TYPICAL REVERSE CHARACTERISTICS



1 AMP FAST RECOVERY SILICON DIODES

FEATURES

- Low cost
- Low leakage
- Low forward voltage drop
- High current capacity
- Fast switching for high efficiency

MECHANICAL DATA

- Case: JEDEC DO-41, molded plastic (U/L Flammability Rating 94V-0)
- Terminals: Plated axial leads
- Soldering: Per MIL-STD 202 Method 208 guaranteed
- Polarity: Color band denotes cathode
- Mounting Position: Any
- Weight: 0.012 Ounces (0.34 Grams)

MECHANICAL SPECIFICATION

ACTUAL SIZE OF
DO-41 PACKAGE

SERIES 1N4933 - 1N4937

DO - 41

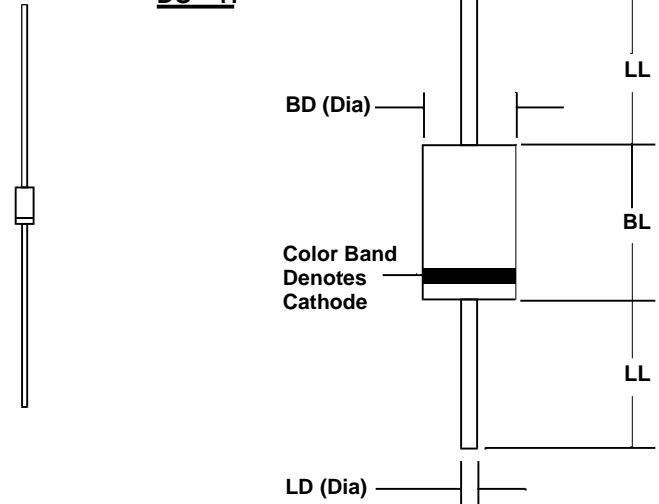

Sym	Minimum		Maximum	
	In	mm	In	mm
BL	0.160	4.1	0.205	5.2
BD	0.103	2.6	0.107	2.7
LL	1.00	25.4		
LD	0.028	0.71	0.034	0.86

MAXIMUM RATINGS & ELECTRICAL CHARACTERISTICS

Ratings at 25 °C ambient temperature unless otherwise specified.
 Single phase, half wave, 60Hz, resistive or inductive load.
 For capacitive loads, derate current by 20%.

PARAMETER (TEST CONDITIONS)	SYMBOL	RATINGS					UNITS
		1N4933	1N4934	1N4935	1N4936	1N4937	
Series Number		1N4933	1N4934	1N4935	1N4936	1N4937	
Maximum DC Blocking Voltage	V _{RM}	50	100	200	400	600	VOLTS
Maximum RMS Voltage	V _{RMS}	35	70	140	280	420	
Maximum Peak Recurrent Reverse Voltage	V _{RRM}	50	100	200	400	600	
Average Forward Rectified Current @ T _A = 75 °C, Lead length = 0.375 in. (9.5 mm)	I _O	1					AMPS
Peak Forward Surge Current (8.3 mSec single half sine wave superimposed on rated load)	I _{FSM}	30					
Maximum Forward Voltage at 1 Amp DC	V _{FM}	1.2					VOLTS
Maximum Reverse Recovery Time (I _F =1A, V _R =30V - See Fig. 5)	T _{RR}	200					nS
Maximum Average DC Reverse Current @ T _A = 25°C At Rated DC Blocking Voltage @ T _A = 100°C	I _{RM}	5 100					μA
Typical Thermal Resistance, Junction to Ambient (Note 1)	R _{θJA}	41					°C/W
Typical Junction Capacitance (Note 2)	C _J	15					pF
Operating and Storage Temperature Range	T _J , T _{STG}	-65 to +175					°C

NOTES: (1) Thermal resistance from junction to ambient with diode mounted on PC Board and lead lengths = 0.375 in. (9.5 mm)
 (2) Measured at 1MHz & applied reverse voltage of 4 volts

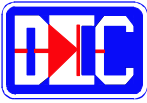

1 AMP FAST RECOVERY SILICON DIODES

RATING & CHARACTERISTIC CURVES FOR SERIES 1N4933 - 1N4937

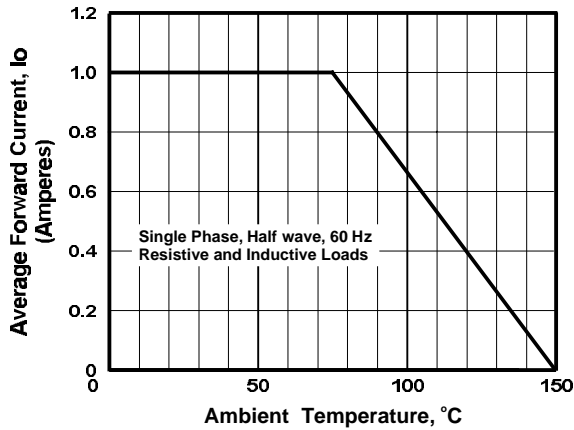

FIGURE 1. FORWARD CURRENT DERATING CURVE

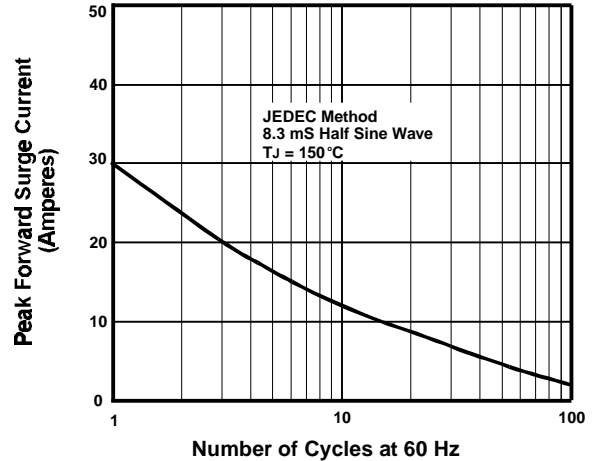

FIGURE 2. MAXIMUM NON-REPETITIVE SURGE CURRENT

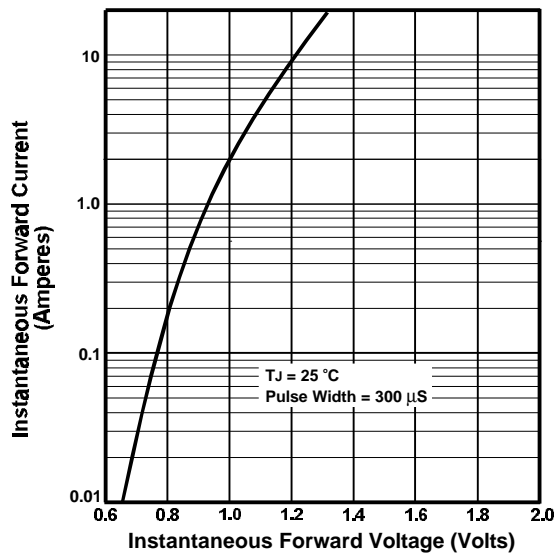

FIGURE 3. TYPICAL FORWARD CHARACTERISTIC PER DIODE

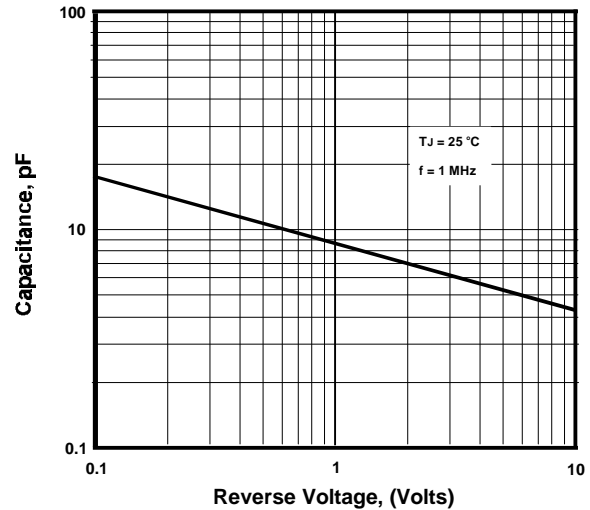

FIGURE 4. TYPICAL JUNCTION CAPACITANCE PER DIODE

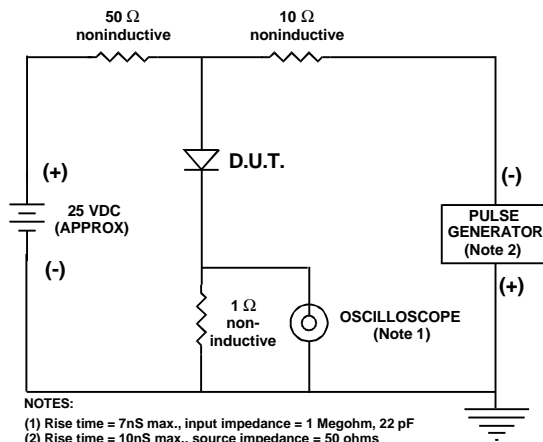
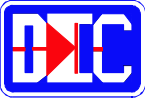

FIGURE 5. REVERSE RECOVERY TEST SETUP AND TIME CHARACTERISTIC



1 AMP FAST RECOVERY SILICON DIODES

FEATURES

- Low cost
- Low leakage
- Low forward voltage drop
- High current capacity
- Fast switching for high efficiency

MECHANICAL DATA

- Case: JEDEC DO-41, molded plastic (U/L Flammability Rating 94V-0)
- Terminals: Plated axial leads
- Soldering: Per MIL-STD 202 Method 208 guaranteed
- Polarity: Color band denotes cathode
- Mounting Position: Any
- Weight: 0.012 Ounces (0.34 Grams)

MECHANICAL SPECIFICATION

ACTUAL SIZE OF
DO-41 PACKAGE

SERIES RP100 - RP110

DO - 41

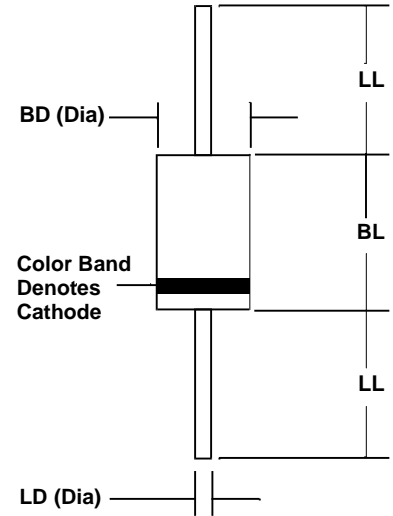

Sym	Minimum		Maximum	
	In	mm	In	mm
BL	0.160	4.1	0.205	5.2
BD	0.103	2.6	0.107	2.7
LL	1.00	25.4		
LD	0.028	0.71	0.034	0.86

MAXIMUM RATINGS & ELECTRICAL CHARACTERISTICS

Ratings at 25 °C ambient temperature unless otherwise specified.
 Single phase, half wave, 60Hz, resistive or inductive load.
 For capacitive loads, derate current by 20%.

PARAMETER (TEST CONDITIONS)	SYMBOL	RATINGS							UNITS
		RP100	RP101	RP102	RP104	RP106	RP108	RP110	
Series Number									
Maximum DC Blocking Voltage	V _{RM}	50	100	200	400	600	800	1000	VOLTS
Maximum RMS Voltage	V _{RMS}	35	70	140	280	420	560	700	
Maximum Peak Recurrent Reverse Voltage	V _{RRM}	50	100	200	400	600	800	1000	
Average Forward Rectified Current @ T _A = 75 °C (Lead length = 0.375 in. (9.5 mm))	I _o	1							AMPS
Peak Forward Surge Current (8.3 mSec single half sine wave superimposed on rated load)	I _{FSM}	30							
Maximum Forward Voltage at 1 Amp DC	V _{FM}	1.3							VOLTS
Maximum Reverse Recovery Time (I _F =0.5A, I _R =1A, I _{RR} =0.25A)	T _{RR}	150			250	500 (Note 3)			nS
Maximum Average DC Reverse Current At Rated DC Blocking Voltage	I _{RM}	5							μA
		50							
Typical Thermal Resistance, Junction to Ambient (Note 1)	R _{θJA}	50							°C/W
Typical Junction Capacitance (Note 2)	C _J	15							pF
Operating and Storage Temperature Range	T _J , T _{STG}	-65 to +175							°C

NOTES: (1) Thermal resistance junction to ambient with diode mounted on PC Board and lead lengths = 0.375 in. (9.5 mm)
 (2) Measured at 1MHz & applied reverse voltage of 4 volts
 (3) 300nS available - consult factory

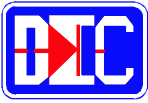

1 AMP FAST RECOVERY SILICON DIODES

RATING & CHARACTERISTIC CURVES FOR SERIES RP100 - RP110

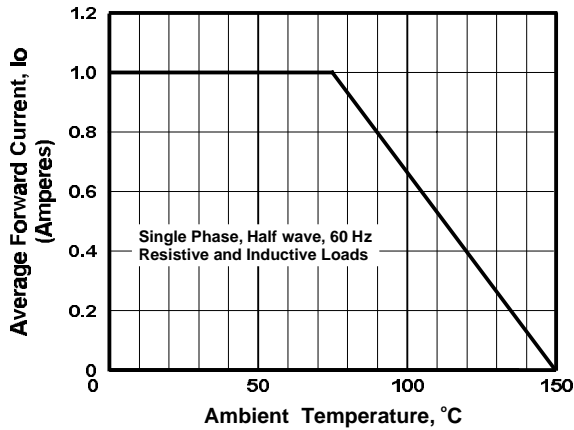

FIGURE 1. FORWARD CURRENT DERATING CURVE

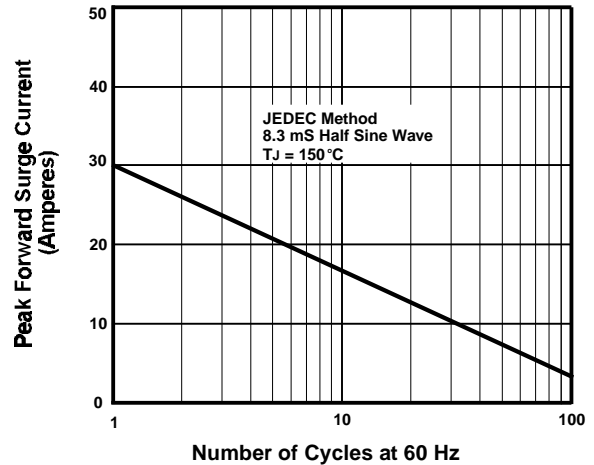

FIGURE 2. MAXIMUM NON-REPETITIVE SURGE CURRENT

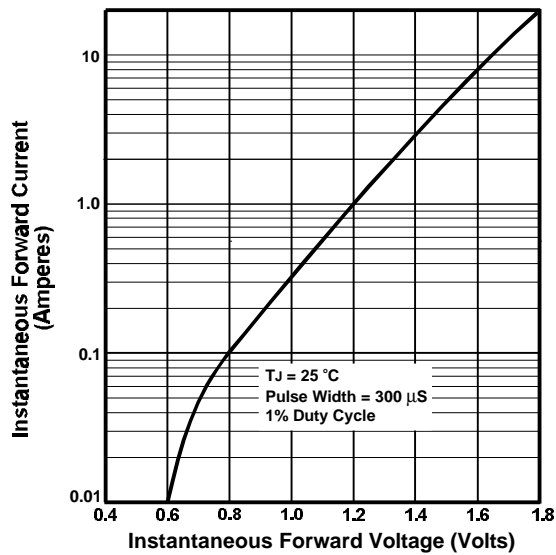

FIGURE 3. TYPICAL FORWARD CHARACTERISTIC

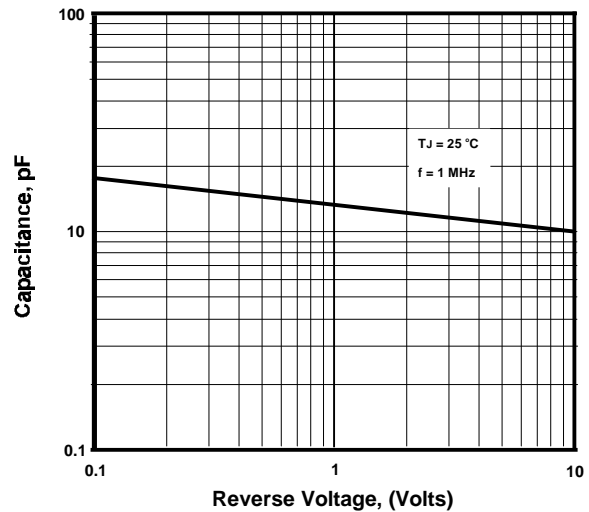

FIGURE 4. TYPICAL JUNCTION CAPACITANCE

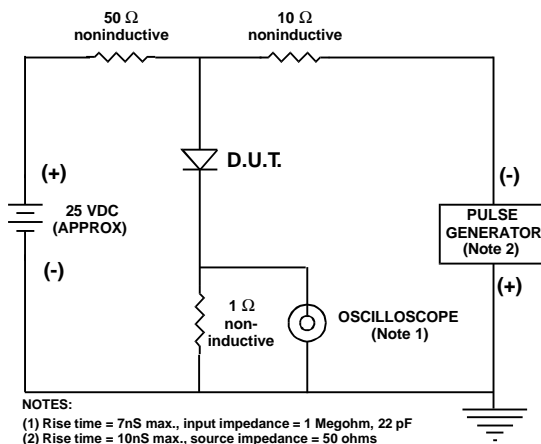
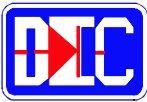

FIGURE 5. REVERSE RECOVERY TEST SETUP AND TIME CHARACTERISTIC



1 AMP HIGH RELIABILITY FAST RECOVERY DIODES

FEATURES

- PROPRIETARY **SOFT GLASS[®]** JUNCTION PASSIVATION FOR SUPERIOR RELIABILITY AND PERFORMANCE
- VOID FREE VACUUM DIE SOLDERING FOR MAXIMUM MECHANICAL STRENGTH AND HEAT DISSIPATION (Solder Voids: Typical $\leq 2\%$, Max. $\leq 10\%$ of Die Area)
- EXTREMELY LOW LEAKAGE AT HIGH TEMPERATURES
- LOW FORWARD VOLTAGE DROP
- 1A at $T_A = 75^\circ\text{C}$ WITH NO THERMAL RUNAWAY

MECHANICAL DATA

- Case: JEDEC DO-41, molded silica glass (U/L Flammability Rating 94V-0)
- Terminals: Plated axial leads
- Soldering: Per MIL-STD 202E Method 208 guaranteed
- Polarity: Color band denotes cathode
- Mounting Position: Any
- Weight: 0.012 Ounces (0.34 Grams)

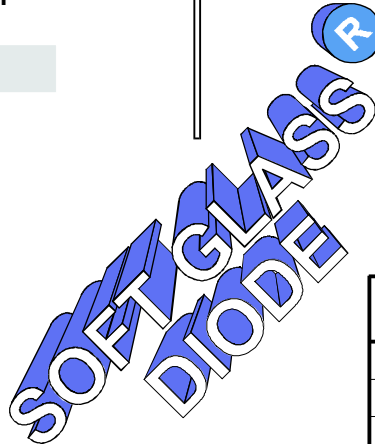

MECHANICAL SPECIFICATION

ACTUAL SIZE OF DO-41 PACKAGE

SERIES RGP100 - RGP110

DO - 41

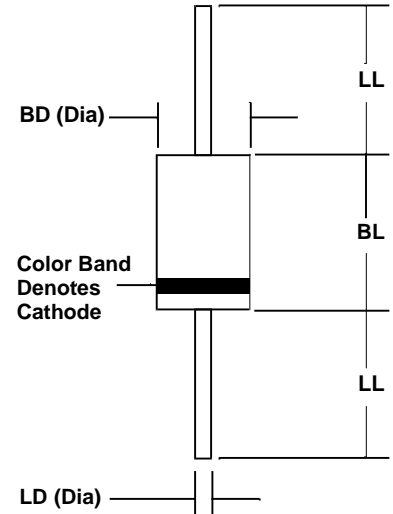

Sym	Minimum		Maximum	
	In	mm	In	mm
BL	0.160	4.1	0.205	5.2
BD	0.103	2.6	0.107	2.7
LL	1.00	25.4		
LD	0.028	0.71	0.034	0.86

MAXIMUM RATINGS & ELECTRICAL CHARACTERISTICS

Ratings at 25 °C ambient temperature unless otherwise specified.
 Single phase, half wave, 60Hz, resistive or inductive load.
 For capacitive loads, derate current by 20%.

PARAMETER (TEST CONDITIONS)	SYMBOL	RATINGS							UNITS
		RGP 100	RGP 101	RGP 102	RGP 104	RGP 106	RGP 108	RGP 110	
Series Number									
Maximum DC Blocking Voltage	V_{RM}	50	100	200	400	600	800	1000	VOLTS
Maximum RMS Voltage	V_{RMS}	35	70	140	280	420	560	700	
Maximum Peak Recurrent Reverse Voltage	V_{RRM}	50	100	200	400	600	800	1000	
Average Forward Rectified Current @ $T_A = 75^\circ\text{C}$, Lead length = 0.375 in. (9.5 mm)	I_o	1							AMPS
Peak Forward Surge Current (8.3 mSec single half sine wave superimposed on rated load)	I_{FSM}	50							
Maximum Forward Voltage at 1 Amp DC	V_{FM}	1.2							VOLTS
Maximum Reverse Recovery Time ($I_F=0.5A$, $I_R=1A$, $I_{RR}=0.25A$)	T_{RR}	150			250	500 (Note 3)			nS
Maximum Average DC Reverse Current At Rated DC Blocking Voltage	I_{RM}	0.5 25							μA
Typical Thermal Resistance, Junction to Ambient (Note 1)	$R_{\theta JA}$	55							$^\circ\text{C/W}$
Typical Junction Capacitance (Note 2)	C_J	15							pF
Operating and Storage Temperature Range	T_J, T_{STG}	-65 to +175							$^\circ\text{C}$

NOTES: (1) Lead length = 0.375 in. (9.5 mm)
 (2) Measured at 1MHz & applied reverse voltage of 4 volts
 (3) 300nS available - consult factory

437f5pd100

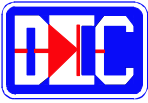

1 AMP HIGH RELIABILITY FAST RECOVERY DIODES

RATING & CHARACTERISTIC CURVES FOR SERIES RGP100 - RGP110

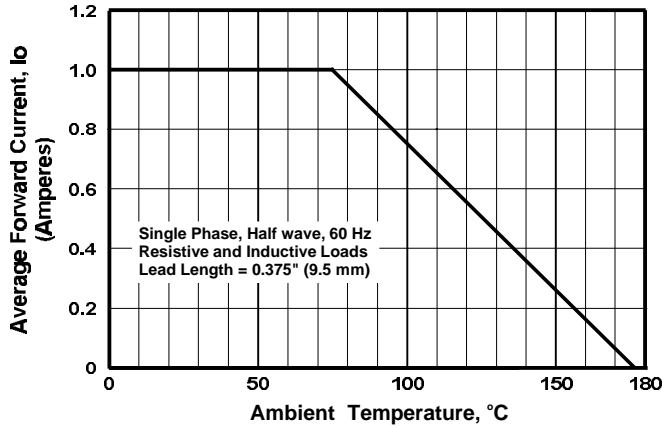

FIGURE 1. FORWARD CURRENT DERATING CURVE

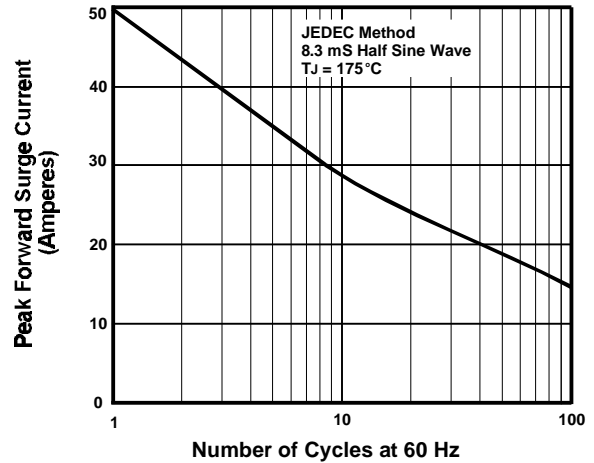

FIGURE 2. MAXIMUM NON-REPETITIVE SURGE CURRENT

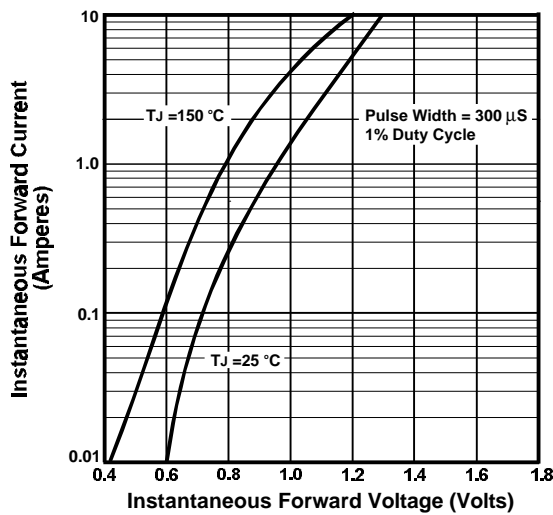

FIGURE 3. TYPICAL FORWARD CHARACTERISTIC

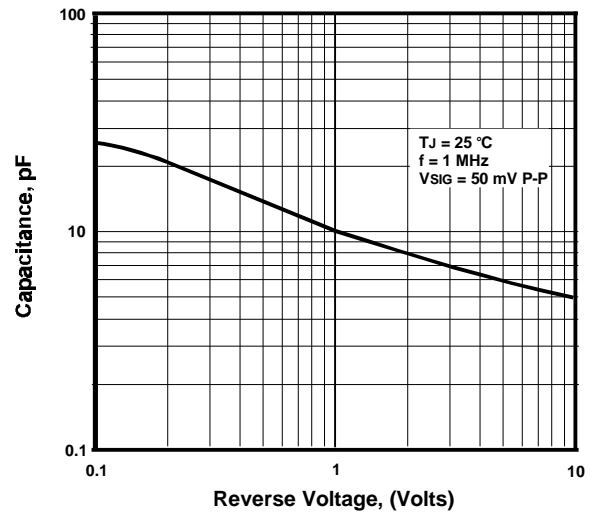

FIGURE 4. TYPICAL JUNCTION CAPACITANCE

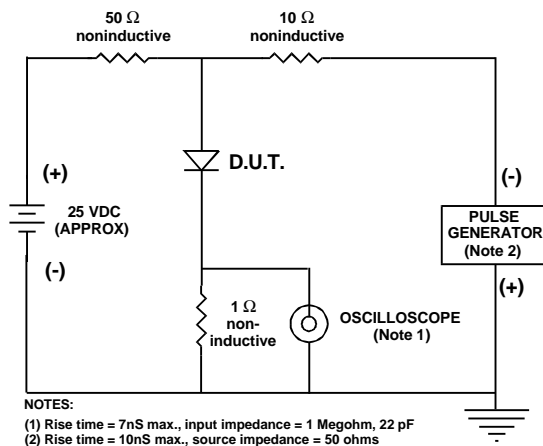
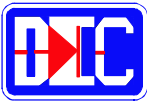

FIGURE 5. REVERSE RECOVERY TEST SETUP AND TIME CHARACTERISTIC



2 AMP FAST RECOVERY SILICON DIODES

FEATURES

- PROPRIETARY **SOFT GLASS®** JUNCTION PASSIVATION FOR SUPERIOR RELIABILITY AND PERFORMANCE
- VOID FREE VACUUM DIE SOLDERING FOR MAXIMUM MECHANICAL STRENGTH AND HEAT DISSIPATION (Solder Voids: Typical $\leq 2\%$, Max. $\leq 10\%$ of Die Area)
- EXTREMELY LOW LEAKAGE AT HIGH TEMPERATURES
- LOW FORWARD VOLTAGE DROP
- 2A at $T_A = 75^\circ\text{C}$ WITH NO THERMAL RUNAWAY

MECHANICAL DATA

- Case: JEDEC DO-41 molded plastic (UL Flammability Rating 94V-0)
- Terminals: Plated axial leads
- Soldering: Per MIL-STD 202 Method 208 guaranteed
- Polarity: Color band denotes cathode
- Mounting Position: Any
- Weight: 0.01 Ounces (0.4 Grams)

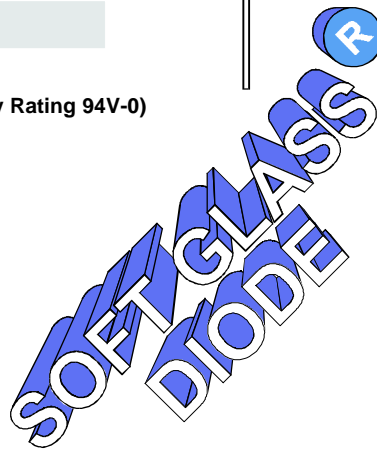

MECHANICAL SPECIFICATION

ACTUAL SIZE OF DO-41 PACKAGE

SERIES RGP200 - RGP210

DO - 41

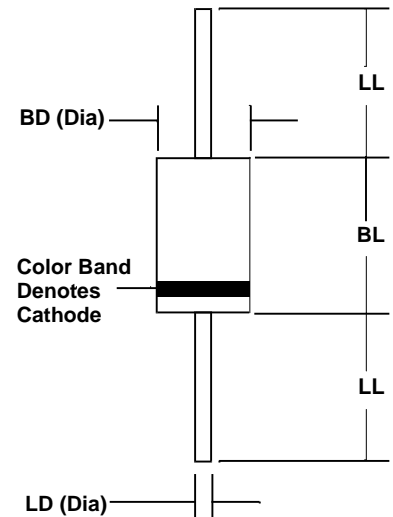

Sym	Minimum		Maximum	
	In	mm	In	mm
BL	0.160	4.1	0.205	5.2
BD	0.103	2.6	0.107	2.7
LL	1.00	25.4		
LD	0.028	0.71	0.034	0.86

MAXIMUM RATINGS & ELECTRICAL CHARACTERISTICS

Ratings at 25°C ambient temperature unless otherwise specified.
 Single phase, half wave, 60Hz, resistive or inductive load.
 For capacitive loads, derate current by 20%.

PARAMETER (TEST CONDITIONS)	SYMBOL	RATINGS							UNITS
		RGP 200	RGP 201	RGP 202	RGP 204	RGP 206	RGP 208	RGP 210	
Series Number									
Maximum DC Blocking Voltage	V_{RM}	50	100	200	400	600	800	1000	VOLTS
Maximum RMS Voltage	V_{RMS}	35	70	140	280	420	560	700	
Maximum Peak Recurrent Reverse Voltage	V_{RRM}	50	100	200	400	600	800	1000	
Average Forward Rectified Current @ $T_A = 75^\circ\text{C}$, Lead length = 0.375 in. (9.5 mm)	I_o	2							AMPS
Peak Forward Surge Current (8.3 mSec single half sine wave superimposed on rated load)	I_{FSM}	60							
Maximum Forward Voltage at 2 Amps DC	V_{FM}	1.3							VOLTS
Maximum Reverse Recovery Time ($I_F=0.5A$, $I_R=1A$, $I_{RR}=0.25A$)	T_{RR}	150			250	500 (Note 2)			nS
Maximum Average DC Reverse Current @ $T_A = 25^\circ\text{C}$ At Rated DC Blocking Voltage @ $T_A = 100^\circ\text{C}$	I_{RM}	1.0 100							μA
Typical Junction Capacitance (Note 1)	C_J	15							pF
Operating and Storage Temperature Range	T_J, T_{STG}	-65 to +175							$^\circ\text{C}$

NOTES: (1) Measured at 1MHz & applied reverse voltage of 4 volts
 (2) 300 nS available - consult factory

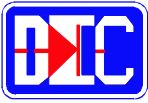

2 AMP FAST RECOVERY SILICON DIODES

RATING & CHARACTERISTIC CURVES FOR SERIES RGP200 - RGP210

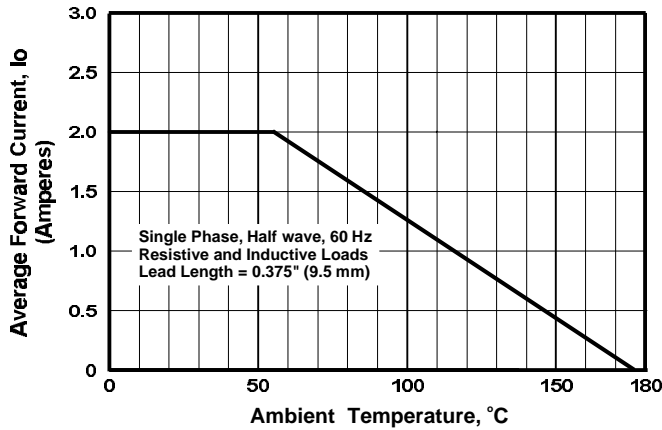

FIGURE 1. FORWARD CURRENT DERATING CURVE

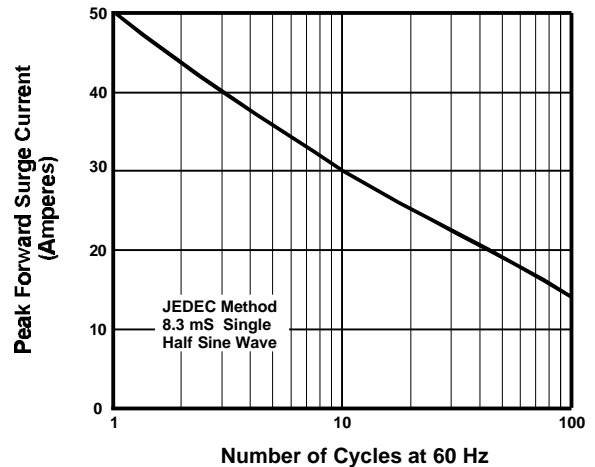

FIGURE 2. MAXIMUM NON-REPETITIVE SURGE CURRENT

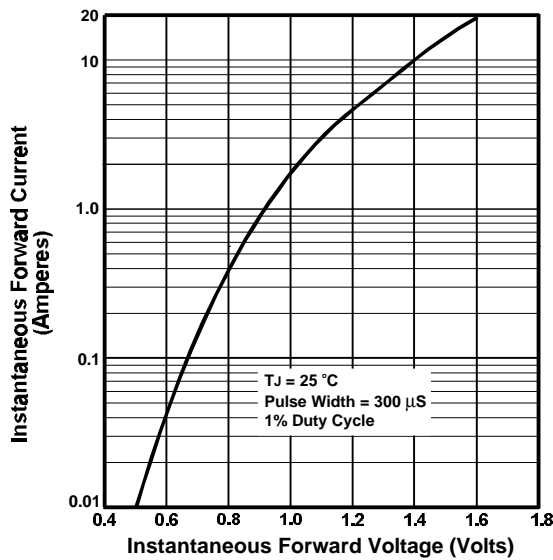

FIGURE 3. TYPICAL FORWARD CHARACTERISTIC

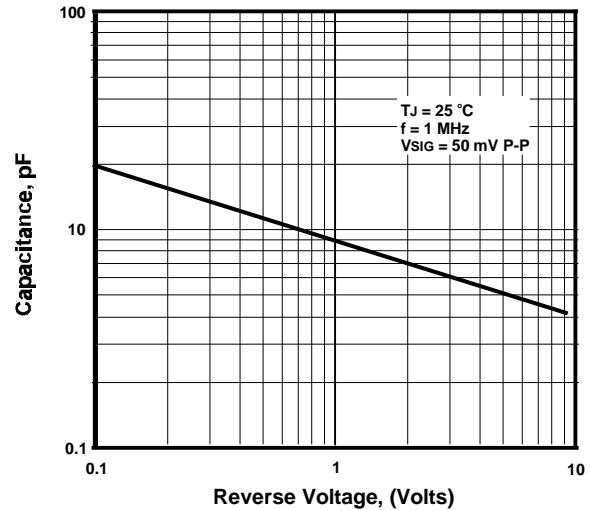

FIGURE 4. TYPICAL JUNCTION CAPACITANCE

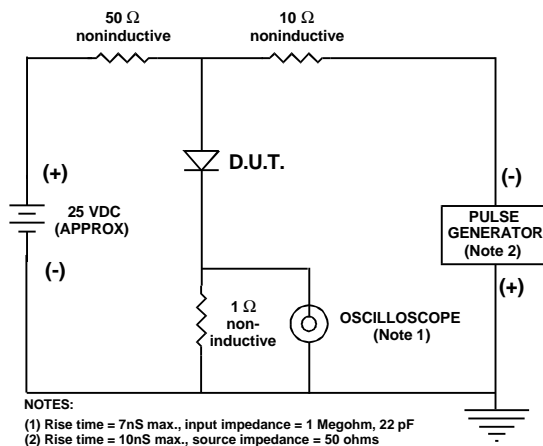
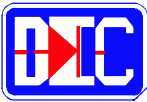

FIGURE 5. REVERSE RECOVERY TEST SETUP AND TIME CHARACTERISTIC



3 AMP FAST RECOVERY SILICON DIODES

FEATURES

- Low cost
- Low leakage
- Low forward voltage drop
- High current capacity
- Fast switching for high efficiency

MECHANICAL DATA

- Case: JEDEC DO-27 molded plastic (U/L Flammability Rating 94V-0)
- Terminals: Plated axial leads
- Soldering: Per MIL-STD 202 Method 208 guaranteed
- Polarity: Color band denotes cathode
- Mounting Position: Any
- Weight: 0.02 Ounces (0.7 Grams)

MECHANICAL SPECIFICATION

ACTUAL SIZE OF
DO-27 PACKAGE

SERIES RP300 - RP310

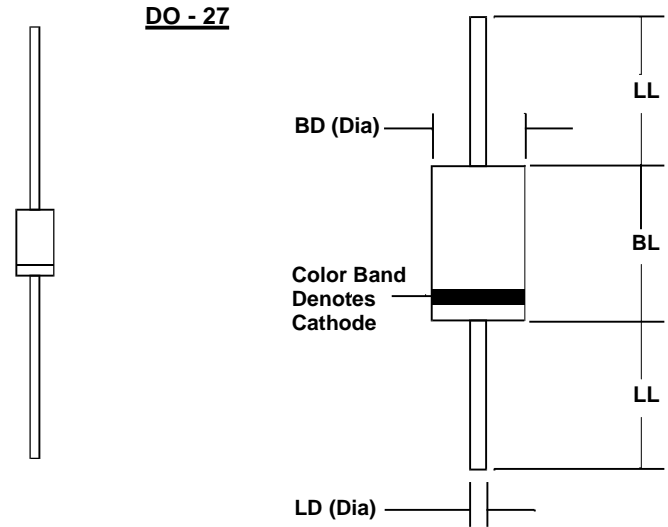

Sym	Minimum		Maximum	
	In	mm	In	mm
BL			0.365	9.28
BD			0.205	5.2
LL	1.00	25.4		
LD	0.048	1.2	0.052	1.3

MAXIMUM RATINGS & ELECTRICAL CHARACTERISTICS

Ratings at 25 °C ambient temperature unless otherwise specified.
 Single phase, half wave, 60Hz, resistive or inductive load.
 For capacitive loads, derate current by 20%.

PARAMETER (TEST CONDITIONS)	SYMBOL	RATINGS								UNITS
		RP300	RP301	RP302	RP304	RP306	RP308	RP310		
Series Number										
Maximum DC Blocking Voltage	V _{RM}	50	100	200	400	600	800	1000		VOLTS
Maximum RMS Voltage	V _{RMS}	35	70	140	280	420	560	700		
Maximum Peak Recurrent Reverse Voltage	V _{RRM}	50	100	200	400	600	800	1000		
Average Forward Rectified Current @ T _A = 55 °C, Lead length = 0.375 in. (9.5 mm)	I _O	3								AMPS
Peak Forward Surge Current (8.3 mSec single half sine wave superimposed on rated load)	I _{FSM}	200								
Maximum Forward Voltage at 3 Amps DC	V _{FM}	1.3								VOLTS
Maximum Reverse Recovery Time (I _F =0.5A, I _R =1A, I _{RR} =0.25A)	T _{RR}	150				250	500 (Note 2)			nS
Maximum Average DC Reverse Current At Rated DC Blocking Voltage	I _{RM}	10 150								μA
Typical Junction Capacitance (Note 1)	C _J	60								pF
Operating and Storage Temperature Range	T _J , T _{STG}	-65 to +175								°C

NOTES: (1) Maximum allowable reverse voltage of 4 volts
 (2) Maximum allowable reverse voltage of 4 volts

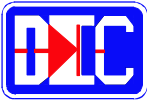

3 AMP FAST RECOVERY SILICON DIODES

RATING & CHARACTERISTIC CURVES FOR SERIES RP300 - RP310

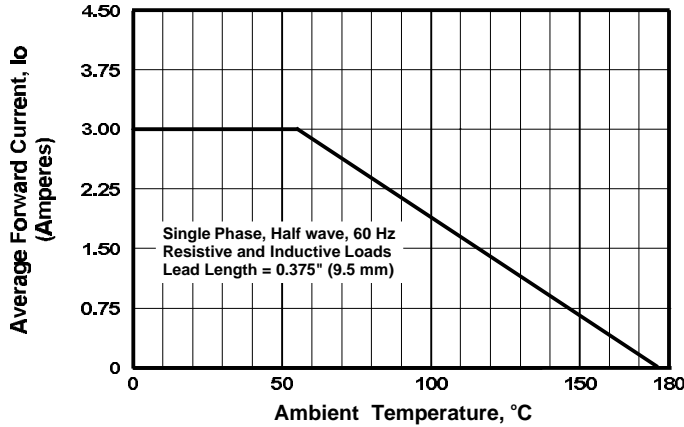

FIGURE 1. FORWARD CURRENT DERATING CURVE

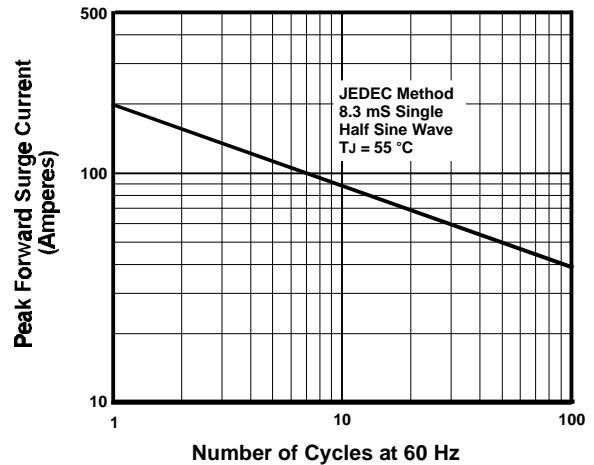

FIGURE 2. MAXIMUM NON-REPETITIVE SURGE CURRENT

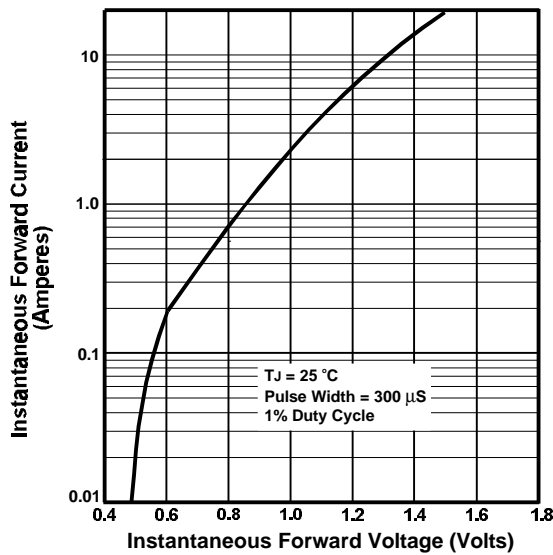

FIGURE 3. TYPICAL FORWARD CHARACTERISTIC

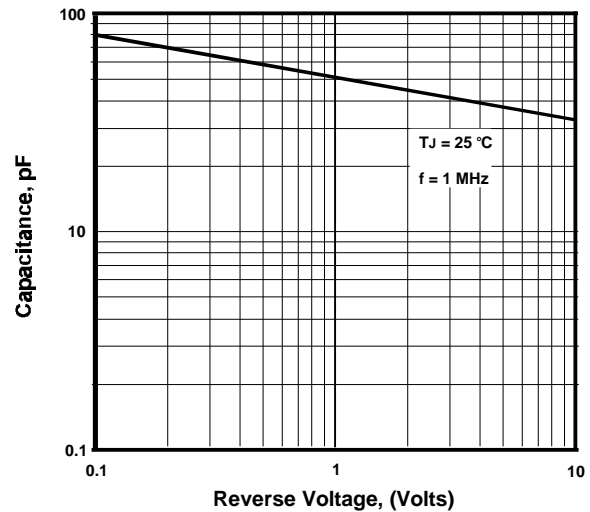

FIGURE 4. TYPICAL JUNCTION CAPACITANCE

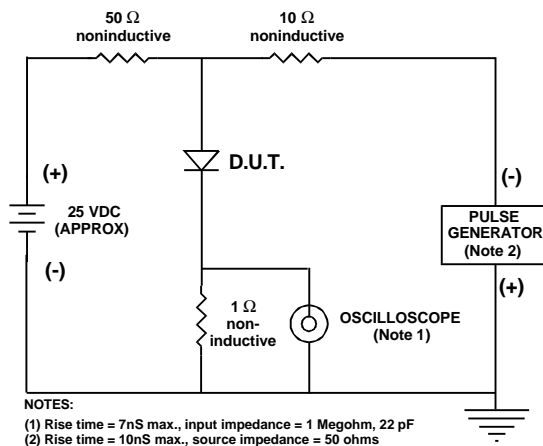
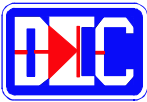

FIGURE 5. REVERSE RECOVERY TEST SETUP AND TIME CHARACTERISTIC



3 AMP HIGH RELIABILITY FAST RECOVERY DIODES

FEATURES

- PROPRIETARY **SOFT GLASS[®]** JUNCTION PASSIVATION FOR SUPERIOR RELIABILITY AND PERFORMANCE
- VOID FREE VACUUM DIE SOLDERING FOR MAXIMUM MECHANICAL STRENGTH AND HEAT DISSIPATION (Solder Voids: Typical $\leq 2\%$, Max. $\leq 10\%$ of Die Area)
- EXTREMELY LOW LEAKAGE AT HIGH TEMPERATURES
- LOW FORWARD VOLTAGE DROP
- 3A at $T_A = 55^\circ\text{C}$ WITH NO THERMAL RUNAWAY

MECHANICAL DATA

- Case: JEDEC DO-27 molded silica glass (U/L Flammability Rating 94V-0)
- Terminals: Plated axial leads
- Soldering: Per MIL-STD 202 Method 208 guaranteed
- Polarity: Color band denotes cathode
- Mounting Position: Any
- Weight: 0.02 Ounces (0.7 Grams)

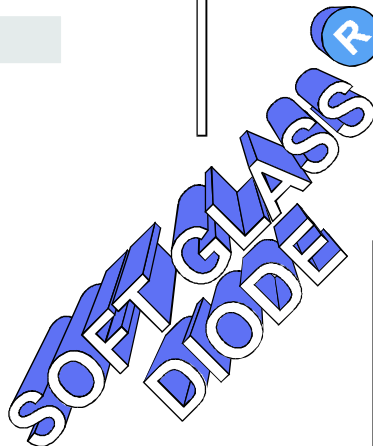

MECHANICAL SPECIFICATION

ACTUAL SIZE OF DO-27 PACKAGE

SERIES RGP300 - RGP310

DO - 27

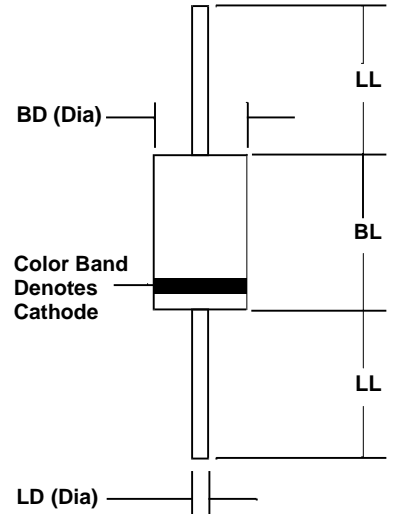

Sym	Minimum		Maximum	
	In	mm	In	mm
BL			0.365	9.28
BD			0.205	5.2
LL	1.00	25.4		
LD	0.048	1.2	0.052	1.3

MAXIMUM RATINGS & ELECTRICAL CHARACTERISTICS

Ratings at 25 °C ambient temperature unless otherwise specified.
 Single phase, half wave, 60Hz, resistive or inductive load.
 For capacitive loads, derate current by 20%.

PARAMETER (TEST CONDITIONS)	SYMBOL	RATINGS							UNITS
		RGP 300	RGP 301	RGP 302	RGP 304	RGP 306	RGP 308	RGP 310	
Series Number									
Maximum DC Blocking Voltage	V_{RM}	50	100	200	400	600	800	1000	VOLTS
Maximum RMS Voltage	V_{RMS}	35	70	140	280	420	560	700	
Maximum Peak Recurrent Reverse Voltage	V_{RRM}	50	100	200	400	600	800	1000	
Average Forward Rectified Current @ $T_A = 55^\circ\text{C}$, Lead length = 0.375 in. (9.5 mm)	I_o	3							AMPS
Peak Forward Surge Current (8.3 mSec single half sine wave superimposed on rated load)	I_{FSM}	200							
Maximum Forward Voltage at 3 Amps DC	V_{FM}	1.2							VOLTS
Maximum Reverse Recovery Time ($I_F=0.5A, I_R=1A, I_{RR}=0.25A$)	T_{RR}	150			250	500 (Note 3)			nS
Maximum Average DC Reverse Current @ $T_A = 25^\circ\text{C}$ At Rated DC Blocking Voltage @ $T_A = 100^\circ\text{C}$	I_{RM}	2 100							μA
Typical Junction Capacitance (Note 2)	C_J	40							pF
Operating and Storage Temperature Range	T_J, T_{STG}	-65 to +175							$^\circ\text{C}$

NOTES: (1) Lead length = 0.375 in. (9.5 mm)
 (2) Measured at 1MHz & applied reverse voltage of 4 volts
 (3) 300 nS available - consult with factory

4.9715sp300

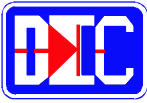

3 AMP HIGH RELIABILITY FAST RECOVERY DIODES

RATING & CHARACTERISTIC CURVES FOR SERIES RGP300 - RGP310

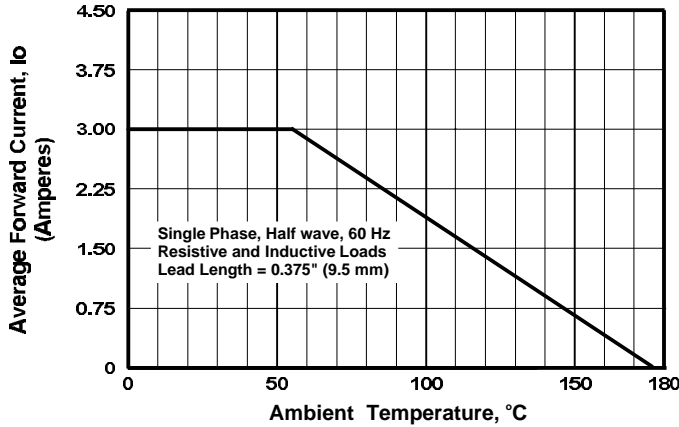

FIGURE 1. FORWARD CURRENT DERATING CURVE

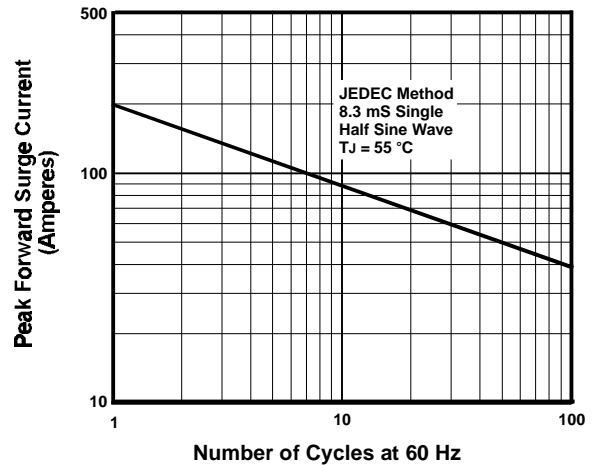

FIGURE 2. MAXIMUM NON-REPETITIVE SURGE CURRENT

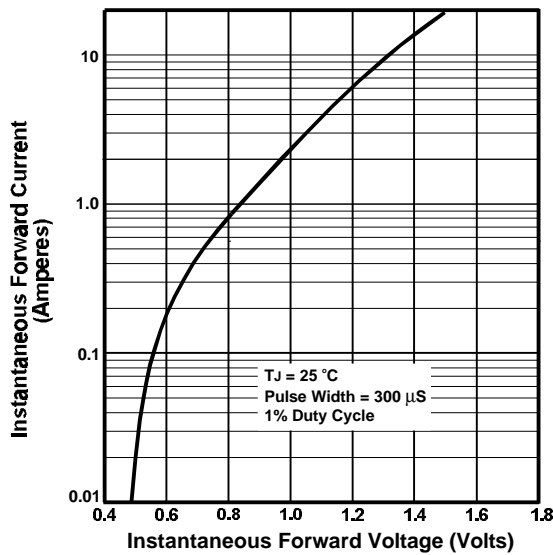

FIGURE 3. TYPICAL FORWARD CHARACTERISTIC

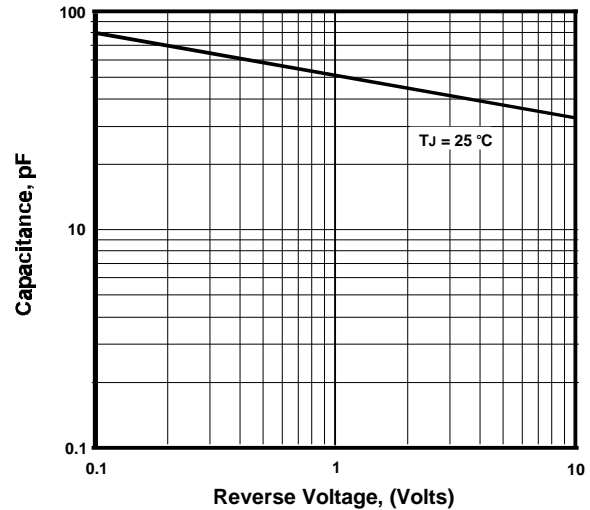

FIGURE 4. TYPICAL JUNCTION CAPACITANCE

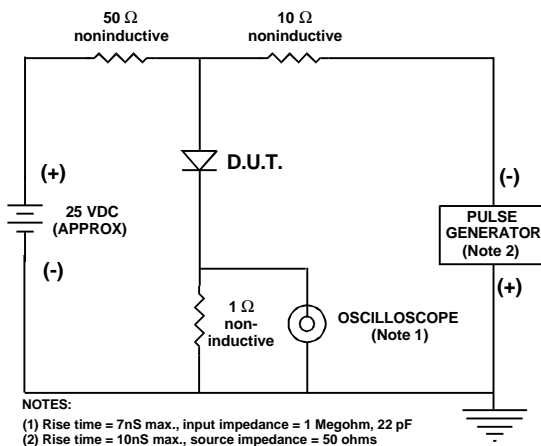

FIGURE 5. REVERSE RECOVERY TEST SETUP AND TIME CHARACTERISTIC



6 AMP FAST RECOVERY SILICON DIODES

FEATURES

- Low cost
- Low leakage
- Low forward voltage drop
- High current capacity
- Fast switching for high efficiency

MECHANICAL DATA

- Case: Molded epoxy (U/L Flammability Rating 94V-0)
- Terminals: Plated axial leads
- Soldering: Per MIL-STD 202 Method 208 guaranteed
- Polarity: Color band denotes cathode
- Mounting Position: Any
- Weight: 0.07 Ounces (2.1 Grams)

MECHANICAL SPECIFICATION

ACTUAL SIZE OF RP600 PACKAGE



SERIES RP600 - RP610

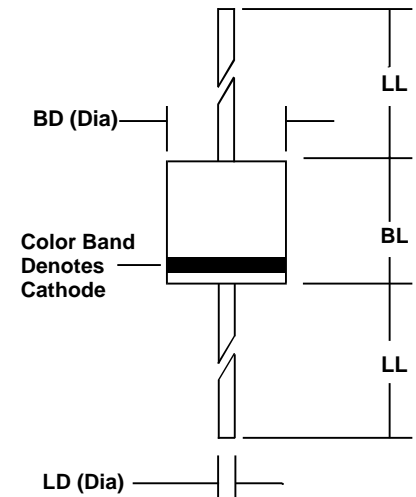

Sym	Minimum		Maximum	
	In	mm	In	mm
BL	0.340	8.6	0.360	9.1
BD	0.340	8.6	0.360	9.1
LL	1.00	25.4		
LD	0.048	1.2	0.052	1.3

MAXIMUM RATINGS & ELECTRICAL CHARACTERISTICS

Ratings at 25 °C ambient temperature unless otherwise specified.
 Single phase, half wave, 60Hz, resistive or inductive load.
 For capacitive loads, derate current by 20%.

PARAMETER (TEST CONDITIONS)	SYMBOL	RATINGS								UNITS
		RP600	RP601	RP602	RP604	RP606	RP608	RP610		
Series Number										
Maximum DC Blocking Voltage	V _{RM}	50	100	200	400	600	800	1000		VOLTS
Maximum RMS Voltage	V _{RMS}	35	70	140	280	420	560	700		
Maximum Peak Recurrent Reverse Voltage	V _{RRM}	50	100	200	400	600	800	1000		
Average Forward Rectified Current @ T _A = 60 °C, Lead length = 0.375 in. (9.5 mm)	I _O	6								AMPS
Peak Forward Surge Current (8.3 mSec single half sine wave superimposed on rated load)	I _{FSM}	300								
Maximum Forward Voltage at 6 Amps DC	V _{FM}	1.3								VOLTS
Maximum Reverse Recovery Time (I _F =0.5A, I _R =1A, I _{RR} =0.25A)	T _{RR}	150				250	500 (Note 3)			nS
Maximum Average DC Reverse Current At Rated DC Blocking Voltage	I _{RM}	10 200								μA
Typical Junction Capacitance (Note 2)	C _J	100								pF
Operating and Storage Temperature Range	T _J , T _{STG}	-65 to +175								°C

NOTES: (1) Lead length = 0.375 in. (9.5 mm)
 (2) Measured at 1MHz & applied reverse voltage of 4 volts
 (3) 300 nS available - consult with factory

01.00ffsdp601

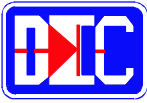

6 AMP FAST RECOVERY DIODES

RATING & CHARACTERISTIC CURVES FOR SERIES RP600 - RP610

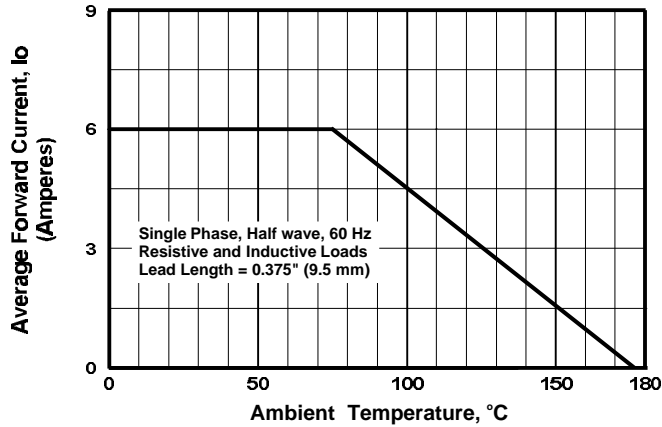

FIGURE 1. FORWARD CURRENT DERATING CURVE

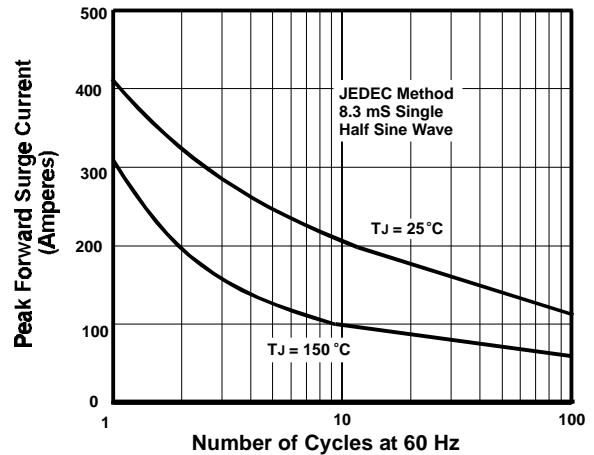

FIGURE 2. MAXIMUM NON-REPETITIVE SURGE CURRENT

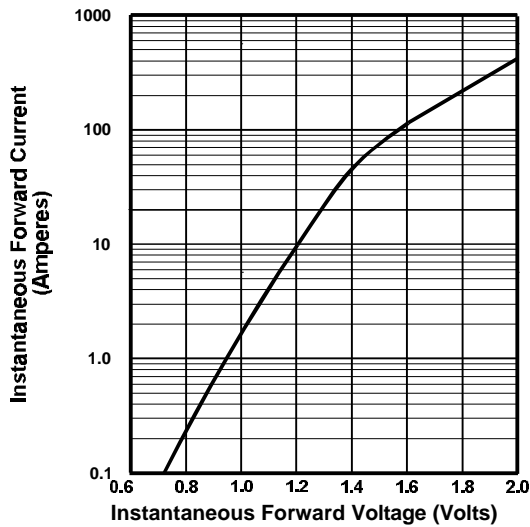

FIGURE 3. TYPICAL FORWARD CHARACTERISTICS

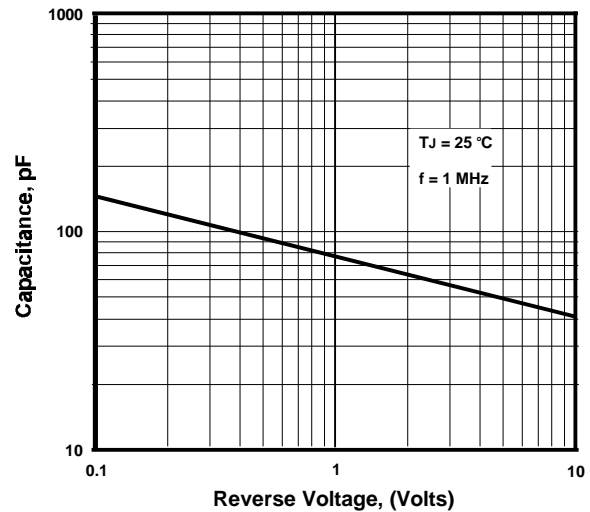

FIGURE 4. TYPICAL JUNCTION CAPACITANCE

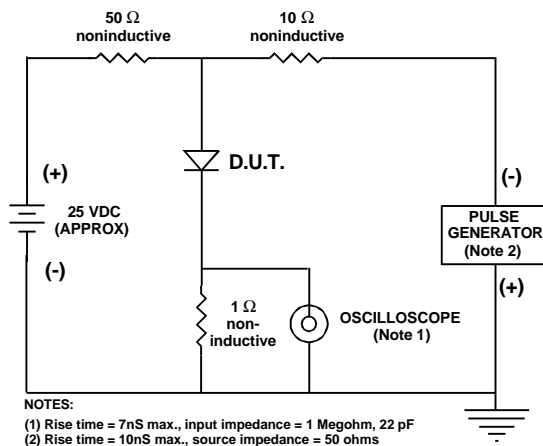
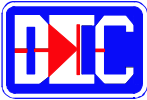

FIGURE 5. REVERSE RECOVERY TEST SETUP AND TIME CHARACTERISTIC



8 AMP FAST RECOVERY RECTIFIERS

FEATURES

- Glass Passivated for high reliability/temperature performance
- Low switching noise
- Low forward voltage drop
- Low thermal resistance
- High surge current capability
- Fast switching for high efficiency
- Low leakage

MECHANICAL SPECIFICATION

ACTUAL SIZE OF
TO-220AC PACKAGE

SERIES RGP800 - RGP806

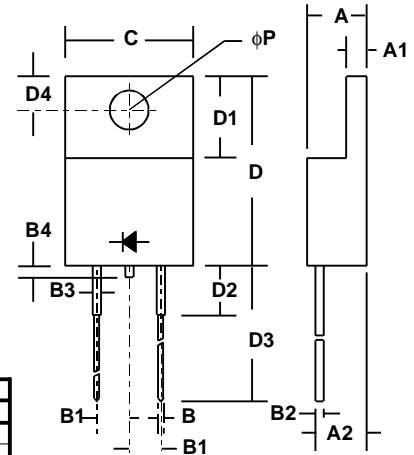
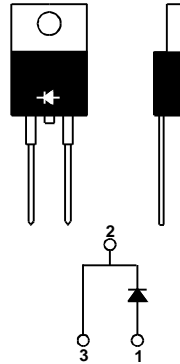

MECHANICAL DATA

- Case: TO-220 molded plastic (U/L Flammability Rating 94V-0)
- Terminals: Plated rectangular pins
- Solderability: Per MIL-STD 202 Method 208 guaranteed
- Polarity: Marked on case
- Mounting Position: Any
- Weight: 0.07 Ounces (2.05 Grams)

Sym	Minimum		Maximum	
	in	mm	in	mm
A			0.187	4.75
A1	0.121*	4.75*		
A2	0.14*	3.56*		
B	0.035	0.9	0.043	1.1
B1	0.09	2.3	0.102	2.6
B2	0.025*	0.64*		
B3	0.050*	1.27*		
B4			0.04	1.0
C			0.413	10.5
D	0.59	15.0	0.61	15.5
D1	0.262*	6.6*		
D2			0.16	4.0
D3	0.54	13.7	0.60	15.2
D4	0.108*	2.75*		
φP	0.126*	3.2*		

TO - 220AC

* These dimensions are "Typicals".

MAXIMUM RATINGS & ELECTRICAL CHARACTERISTICS

Ratings at 25 °C ambient temperature unless otherwise specified.
 Single phase, half wave, 60Hz, resistive or inductive load.
 For capacitive loads, derate current by 20%.

PARAMETER (TEST CONDITIONS)	SYMBOL	RATINGS					UNITS
		RGP800	RGP801	RGP802	RGP804	RGP806	
Series Number							
Maximum DC Blocking Voltage	V _{RM}	50	100	200	400	600	VOLTS
Maximum RMS Voltage	V _{RMS}	35	70	140	280	420	
Maximum Peak Recurrent Reverse Voltage	V _{RRM}	50	100	200	400	600	
Average Forward Rectified Current @ T _c = 110 °C	I _o	8					AMPS
Peak Forward Surge Current (8.3mS single half sine wave superimposed on rated load)	I _{FSM}	150					
Maximum Forward Voltage at 8 Amps DC	V _{FM}	1.3					VOLTS
Maximum Average DC Reverse Current @ T _c = 25 °C	I _{RM}	10					μA
At Rated DC Blocking Voltage @ T _c = 100 °C		250					
Typical Thermal Resistance, Junction to Case	R _{θJC}	3					°C/W
Typical Junction Capacitance (Note 1)	C _J	55					pF
Maximum Reverse Recovery Time (I _F =0.5A, I _R =1A, I _{RR} =0.25A)	T _{RR}	150			200	250	nSec
Junction Operating and Storage Temperature Range	T _J , T _{STG}	-50 to +150					°C

NOTES: (1) Measured at 1MHz and an applied reverse voltage of 4 volts.

4.971fsg800

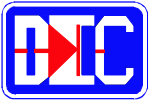

8 AMP FAST RECOVERY DIODES

RATING & CHARACTERISTIC CURVES FOR SERIES RGP800 - RGP806

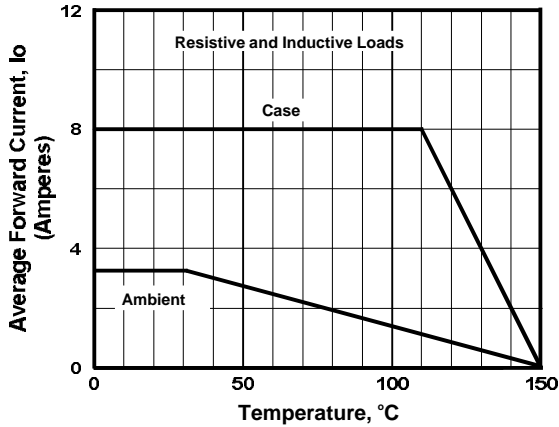

FIGURE 1. FORWARD CURRENT DERATING CURVE

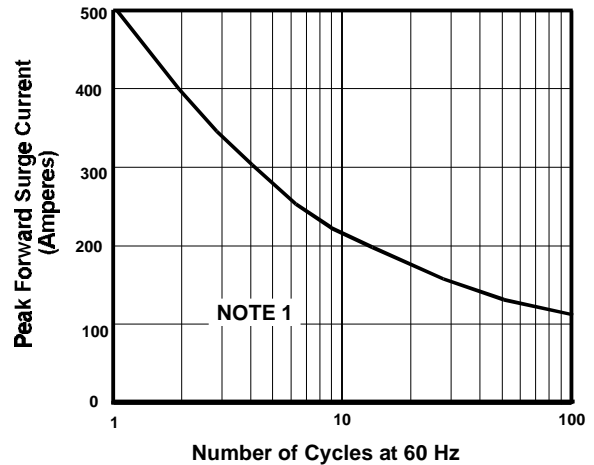

FIGURE 2. MAXIMUM NON-REPETITIVE SURGE CURRENT

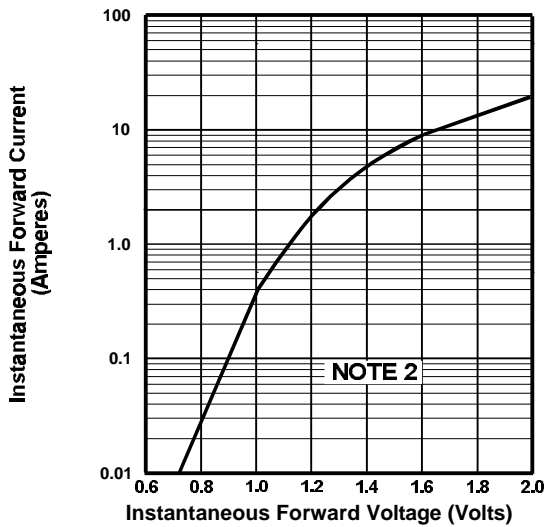

FIGURE 3. TYPICAL FORWARD CHARACTERISTICS

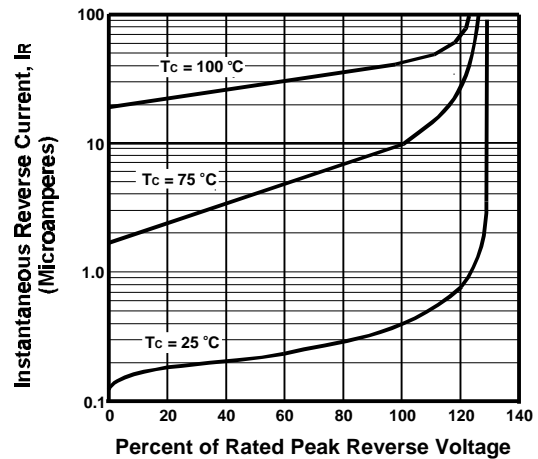

FIGURE 4. TYPICAL REVERSE CHARACTERISTICS

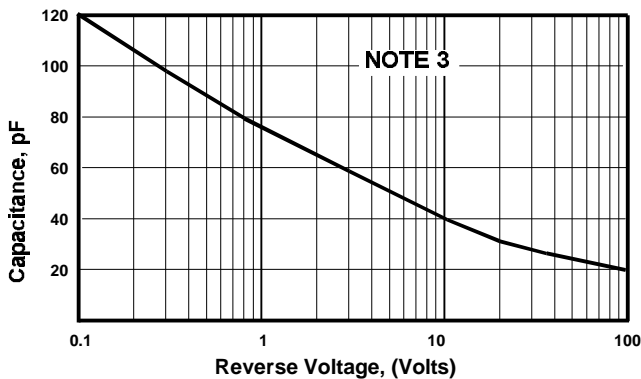

FIGURE 5. TYPICAL JUNCTION CAPACITANCE

NOTES

- (1) JEDEC Method, 8.3 mSec. Single Half Sine Wave, T_J = 150 °C
- (2) T_J = 25 °C, Pulse Width = 300 μSec, 2.0% Duty Cycle
- (3) T_J = 25 °C, f = 1 MHz

SECTION I

HIGH

VOLTAGE

DIODES

STANDARD AND FAST RECOVERY

DO-41 PACKAGE
200 to 500 MILLIAMPERES
1200 to 5000 VOLTS

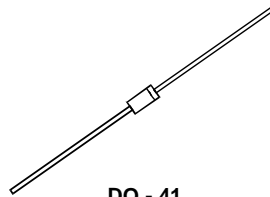

DO - 41

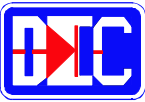

HIGH VOLTAGE DIODE RECTIFIERS

FEATURES

- PROPRIETARY **SOFT GLASS[®]** JUNCTION PASSIVATION FOR SUPERIOR RELIABILITY AND PERFORMANCE
- VOID FREE VACUUM DIE SOLDERING FOR MAXIMUM MECHANICAL STRENGTH AND HEAT DISSIPATION (Solder Voids: Typical $\leq 2\%$, Max. $\leq 10\%$ of Die Area)
- EXTREMELY LOW LEAKAGE AT HIGH TEMPERATURES
- LOW FORWARD VOLTAGE DROP
- HIGH CURRENT CAPABILITY

MECHANICAL DATA

- Case: JEDEC DO-41 molded plastic (U/L Flammability Rating 94V-0)
- Terminals: Plated axial leads
- Soldering: Per MIL-STD 202 Method 208 guaranteed
- Polarity: Color band denotes cathode
- Mounting Position: Any
- Weight: DO-41 - 0.012 Ounces (0.34 Grams)

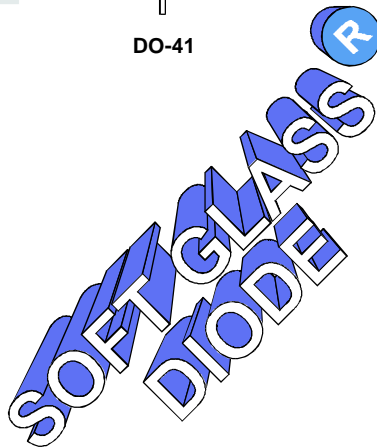

MECHANICAL SPECIFICATION

ACTUAL SIZE OF DO-41 PACKAGE

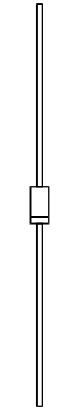

DO-41

SERIES GP1120 - GP1500

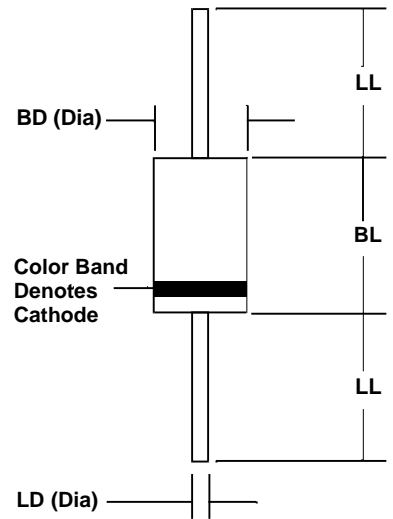

Sym	Minimum		Maximum	
	In	mm	In	mm
BL	0.160	4.1	0.205	5.2
BD	0.103	2.6	0.107	2.7
LL	1.00	25.4		
LD	0.028	0.71	0.034	0.86

MAXIMUM RATINGS & ELECTRICAL CHARACTERISTICS

Ratings at 25 °C ambient temperature unless otherwise specified.
 Single phase, half wave, 60Hz, resistive or inductive load.
 For capacitive loads, derate current by 20%.

PARAMETER (TEST CONDITIONS)	SYMBOL	RATINGS										UNITS
		GP 1150	GP 1180	GP 1200	GP 1250	GP 1300	GP 1400	GP 1500	GP 1600			
Series Number												
Maximum DC Blocking Voltage	V _{RM}	1500	1800	2000	2500	3000	4000	5000	6000			VOLTS
Maximum RMS Voltage	V _{RMS}	1050	1260	1400	1750	2100	2800	3500	4200			
Maximum Peak Recurrent Reverse Voltage	V _{RRM}	1500	1800	2000	2500	3000	4000	5000	6000			
Average Forward Rectified Current @ T _A = 50 °C, Lead length = 0.375 in. (9.5 mm)	I _o	1000			500			200				mA
Peak Forward Surge Current (8.3 mSec single half sine wave superimposed on rated load)	I _{FSM}	35			25			15				AMPS
Maximum Forward Voltage at Rated Forward Current	V _{FM}	1.5			3.0			4.5	6.0			VOLTS
Maximum Average DC Reverse Current At Rated DC Blocking Voltage @ T _A = 25°C	I _{RM}	1.0										μA
Typical Junction Capacitance (Note 1)	C _J	12										pF
Operating and Storage Temperature Range	T _J , T _{STG}	-65 to +150										°C

NOTES: (1) Measured at 1MHz & applied reverse voltage of 4 volts

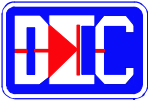

HIGH VOLTAGE DIODE RECTIFIERS

RATING & CHARACTERISTIC CURVES FOR SERIES GP1150 - GP1600

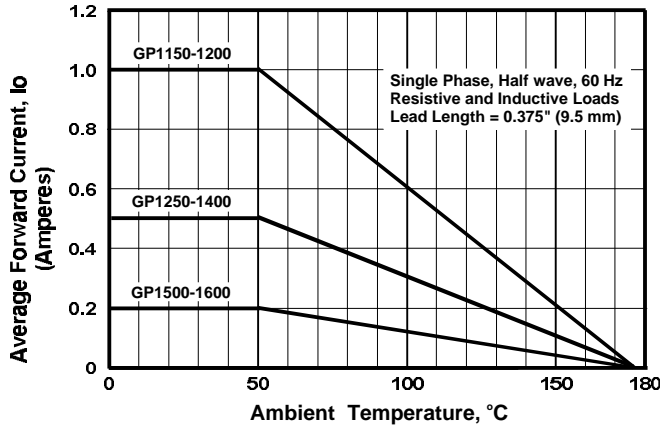

FIGURE 1. FORWARD CURRENT DERATING CURVE

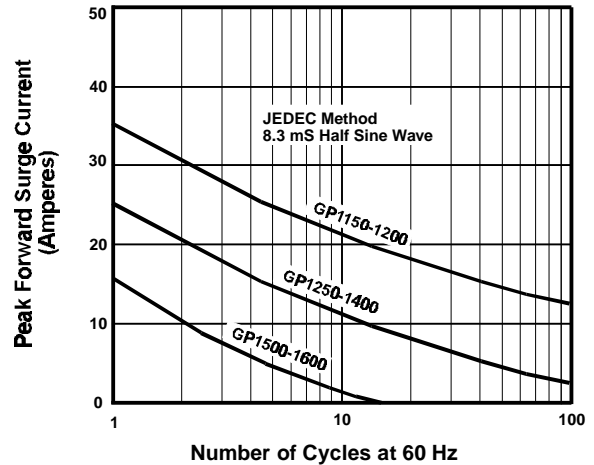

FIGURE 2. MAXIMUM NON-REPETITIVE SURGE CURRENT

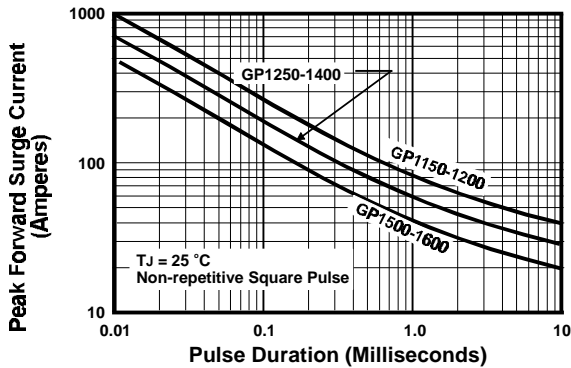

FIGURE 6. PEAK FORWARD SURGE CURRENT

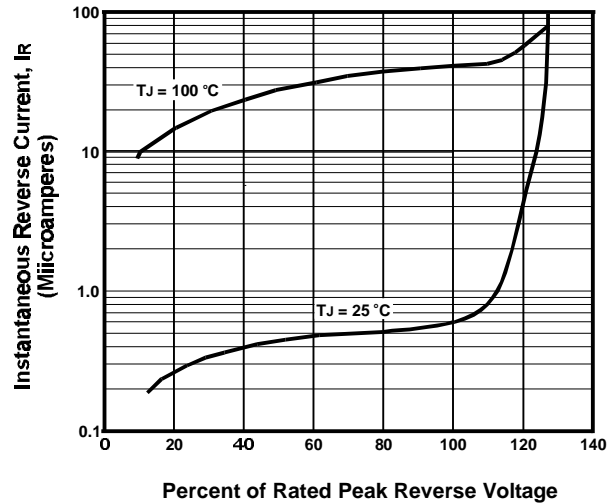

FIGURE 4. TYPICAL REVERSE CHARACTERISTICS

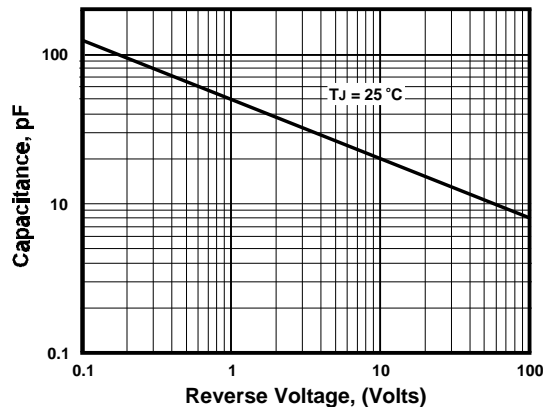
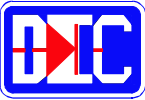

FIGURE 5. TYPICAL JUNCTION CAPACITANCE PER DIODE



HIGH VOLTAGE FAST RECOVERY DIODES

FEATURES

- PROPRIETARY **SOFT GLASS[®]** JUNCTION PASSIVATION FOR SUPERIOR RELIABILITY AND PERFORMANCE
- VOID FREE VACUUM DIE SOLDERING FOR MAXIMUM MECHANICAL STRENGTH AND HEAT DISSIPATION (Solder Voids: Typical $\leq 2\%$, Max. $\leq 10\%$ of Die Area)
- EXTREMELY LOW LEAKAGE AT HIGH TEMPERATURES
- LOW FORWARD VOLTAGE DROP
- HIGH CURRENT CAPABILITY

MECHANICAL DATA

- Case: JEDEC DO-41 molded plastic (U/L Flammability Rating 94V-0)
- Terminals: Plated axial leads
- Soldering: Per MIL-STD 202 Method 208 guaranteed
- Polarity: Color band denotes cathode
- Mounting Position: Any
- Weight: DO-41 - 0.012 Ounces (0.34 Grams)

SOFT GLASS
DIODE

MECHANICAL SPECIFICATION

ACTUAL SIZE OF DO-41 PACKAGE

SERIES RP1120 - RP1500

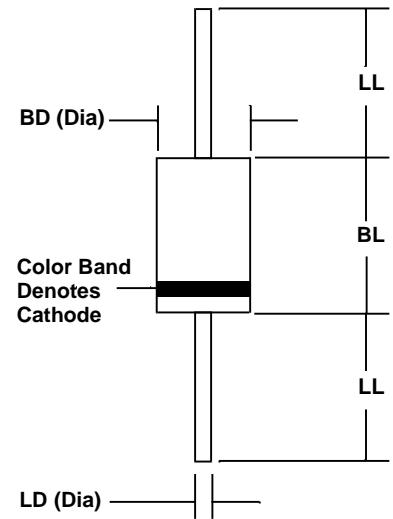
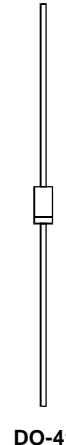

Sym	Minimum		Maximum	
	In	mm	In	mm
BL	0.160	4.1	0.205	5.2
BD	0.103	2.6	0.107	2.7
LL	1.00	25.4		
LD	0.028	0.71	0.034	0.86

MAXIMUM RATINGS & ELECTRICAL CHARACTERISTICS

Ratings at 25 °C ambient temperature unless otherwise specified.
 Single phase, half wave, 60Hz, resistive or inductive load.
 For capacitive loads, derate current by 20%.

PARAMETER (TEST CONDITIONS)	SYMBOL	RATINGS									UNITS
		RGP 1120	RGP 1150	RGP 1180	RGP 1200	RGP 1250	RGP 1300	RGP 1400	RGP 1500		
Series Number											
Maximum DC Blocking Voltage	V _{RM}	1200	1500	1800	2000	2500	3000	4000	5000		VOLTS
Maximum RMS Voltage	V _{RMS}	840	1050	1260	1400	1750	2100	2800	3500		
Maximum Peak Recurrent Reverse Voltage	V _{RRM}	1200	1500	1800	2000	2500	3000	4000	5000		
Average Forward Rectified Current @ T _A = 50 °C (Lead length = 0.375 in. (9.5 mm))	I _o	800			400			200			mA
Peak Forward Surge Current (8.3 mSec single half sine wave superimposed on rated load)	I _{FSM}	30			20			10			AMPS
Maximum Forward Voltage at Rated Forward Current	V _{FM}	2.5			4.5			6.5			VOLTS
Maximum Average DC Reverse Current At Rated DC Blocking Voltage @ T _A = 25 °C	I _{RM}	1.0									µA
Maximum Reverse Recovery Time (I _F =0.5A, I _R =1A, I _{RR} =0.25A)	T _{RR}	500									nS
Operating and Storage Temperature Range	T _J , T _{STG}	-65 to +125				-65 to +150					°C

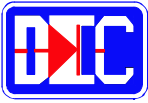

HIGH VOLTAGE FAST RECOVERY RECTIFIERS

RATING & CHARACTERISTIC CURVES FOR SERIES RGP1120 - RGP1500

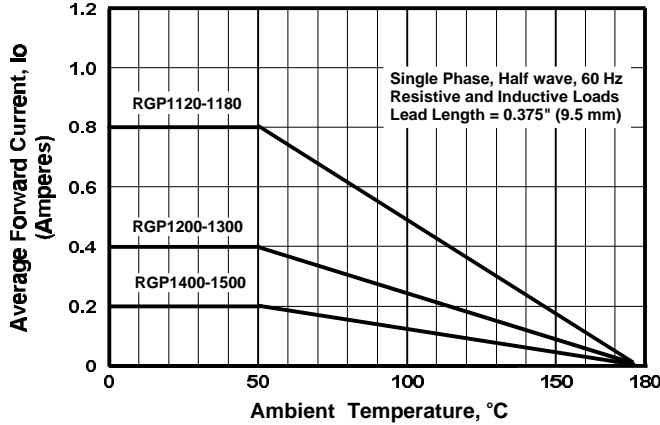

FIGURE 1. FORWARD CURRENT DERATING CURVE

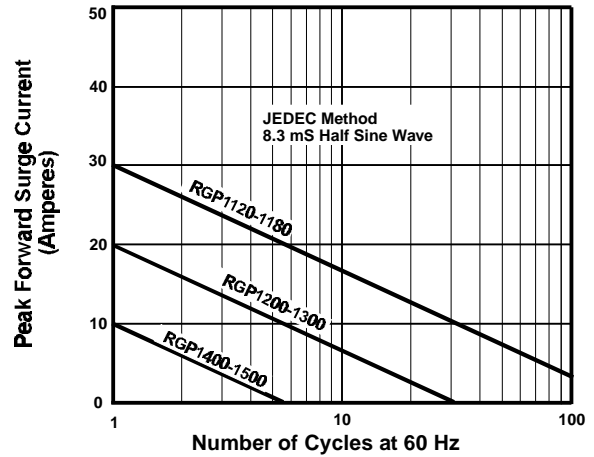

FIGURE 2. MAXIMUM NON-REPETITIVE SURGE CURRENT

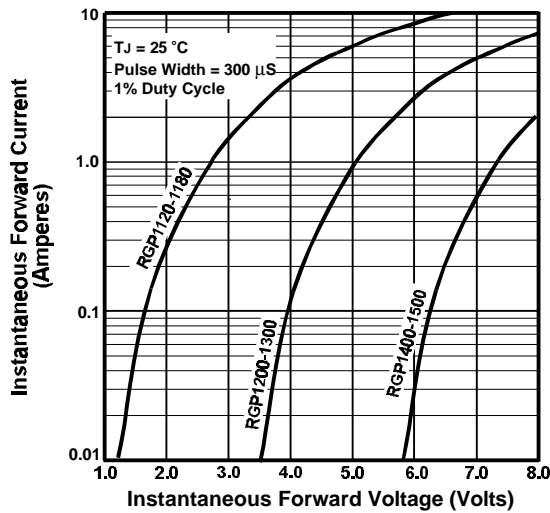

FIGURE 3. TYPICAL FORWARD CHARACTERISTIC

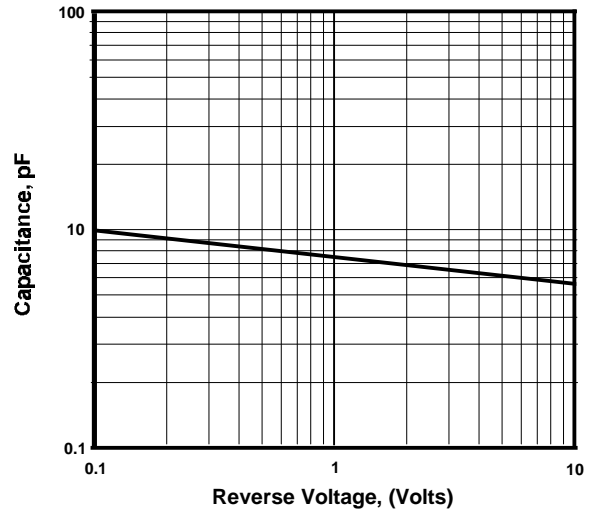

FIGURE 4. TYPICAL JUNCTION CAPACITANCE

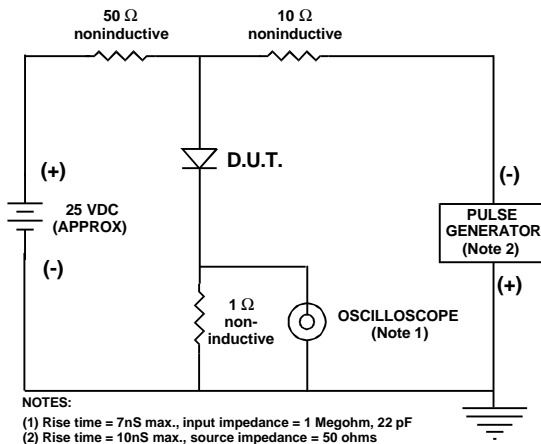
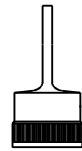

FIGURE 5. REVERSE RECOVERY TEST SETUP AND TIME CHARACTERISTIC

AUTOMOTIVE DIODES

Transient Voltage Suppressors (Section J)

PRESS FIT



MOLDED PRODUCTS



DIODE CELLS



AXIAL LEAD

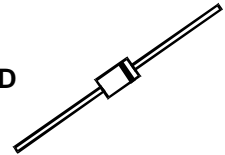

Standard Diodes (Section K)

MOLDED PRODUCTS



DIODE CELLS



SECTION J
AUTOMOTIVE DIODES
TRANSIENT VOLTAGE
SUPPRESSORS

PRESS FIT

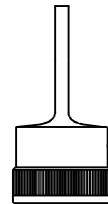

MOLDED PRODUCTS



DIODE CELLS



AXIAL LEAD

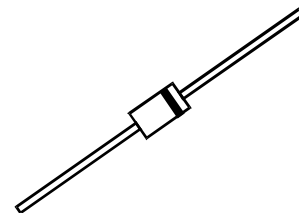

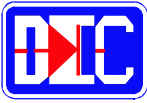

35 AMP PRESS FIT TVS DIODES

FEATURES

- PROPRIETARY **SOFT GLASS[®]** JUNCTION PASSIVATION FOR SUPERIOR RELIABILITY AND PERFORMANCE
- VOID FREE VACUUM DIE SOLDERING FOR MAXIMUM MECHANICAL STRENGTH AND HEAT DISSIPATION (Solder Voids: Typical < 2%, Max. < 10% of Die Area)
- Large die for high power capability
- Very low forward voltage drop
- Increased capacity by parallel operation
- Protects expensive automotive electronics and mobile equipment

MECHANICAL DATA

- Case: Nickel plated copper
- Finish: All external surfaces are corrosion resistant and the contact areas are readily solderable
- Soldering Temperature: 250 °C maximum
- Mounting Position: Any. Maximum force used for diode insertion to be 12 KN
- Polarity: Color coded polarity mark and part number on cap base (ANODE on LEAD; Part No.=TVS3527PFA) (CATHODE on LEAD; Part No.=TVS3527PFC)

MECHANICAL SPECIFICATION

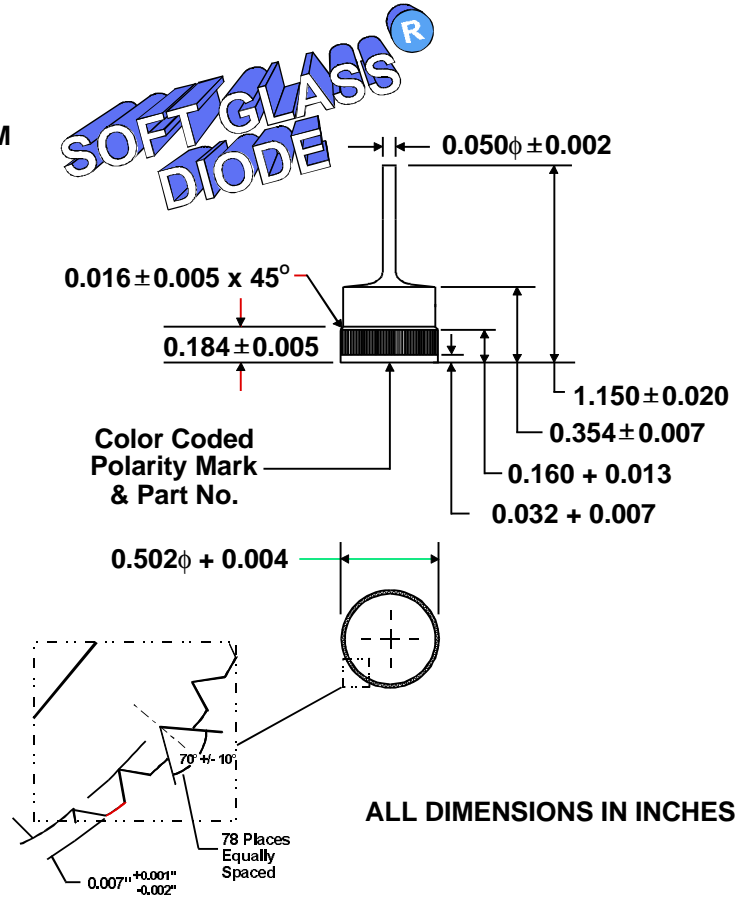

MAXIMUM RATINGS & ELECTRICAL CHARACTERISTICS

Ratings at 25 °C ambient temperature unless otherwise specified.

PARAMETER (TEST CONDITIONS)	SYMBOL	RATINGS		UNITS
		TVS3527PFC	TVS3527PFA	
Series Number				
Maximum Recurrent Peak Reverse Voltage	V _{RRM}	23	23	VOLTS
Working Peak Reverse Voltage	V _{RWM}			
Maximum DC Blocking Voltage	V _{DC}			
Breakdown Voltage (I _R = 100 mA dc, T _c = 25 °C)	V _(BR)	24 Min / 32 Max	24 Min / 32 Max	
Average Forward Rectified Current	I _o	35	35	AMPS
Non-repetitive Peak Forward Surge Current (Half wave, single phase, 60 Hz sine applied to rated load)	I _{FSM}	600	600	
Repetitive Peak Reverse Surge Current (Time Constant = 10 mSec Duty Cycle ≤ 1.0%, T _c = 25 °C)	I _{RSM}	110	110	
Instantaneous Forward Voltage (I _F = 100A @ 300 μSec pulse, T _c = 25 °C)	V _F	1.05 1.00	1.05 1.00	VOLTS
Maximum DC Reverse Current (V _R = 20V DC, T _c = 25 °C)	I _R	200	200	nA
Maximum Thermal Resistance, Junction to Case (Note 1)	R _{θJC}	0.8	0.8	°C/W
Junction Operating & Storage Temperature Range	T _J , T _{STG}	-65 to +175	-65 to +175	°C

Notes: 1) Single Side Cooled

3.011vs3527pf

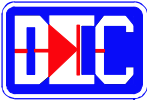

60 AMP PRESS FIT TVS DIODES

FEATURES

- PROPRIETARY **SOFT GLASS[®]** JUNCTION PASSIVATION FOR SUPERIOR RELIABILITY AND PERFORMANCE
- VOID FREE VACUUM DIE SOLDERING FOR MAXIMUM MECHANICAL STRENGTH AND HEAT DISSIPATION (Solder Voids: Typical < 2%, Max. < 10% of Die Area)
- Large die for high power capability
- Very low forward voltage drop
- Increased capacity by parallel operation
- Protects expensive automotive electronics and mobile equipment

MECHANICAL SPECIFICATION

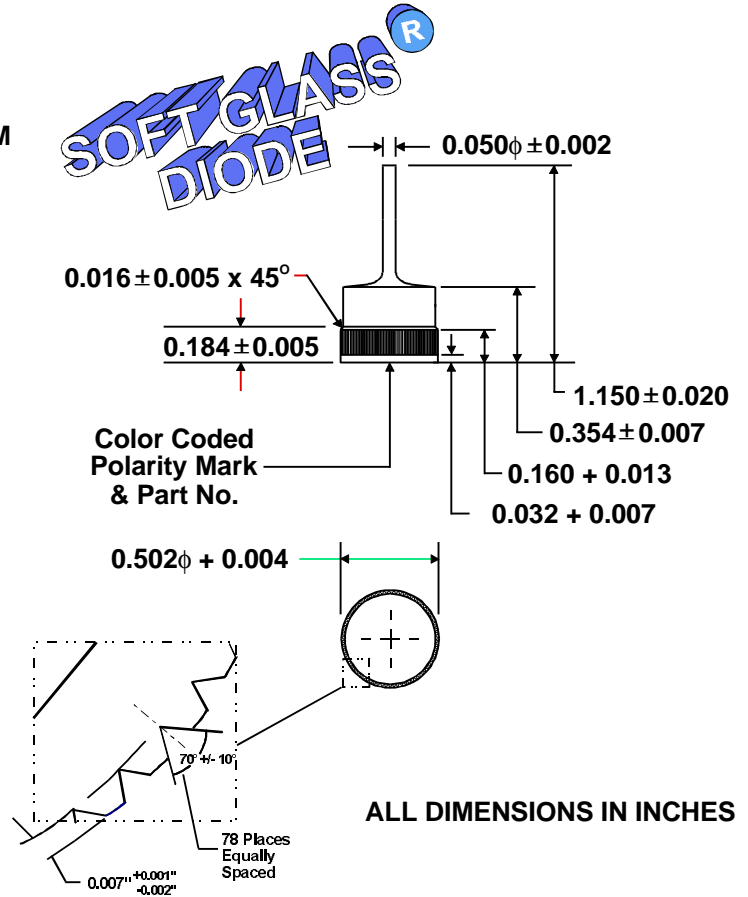

MECHANICAL DATA

- Case: Nickel plated copper
- Finish: All external surfaces are corrosion resistant and the contact areas are readily solderable
- Soldering Temperature: 250 °C maximum
- Mounting Position: Any. Maximum force used for diode insertion to be 12 KN
- Polarity: Color coded polarity mark and part number on cap base (ANODE on LEAD; Part No.=TVS6027PFA) (CATHODE on LEAD; Part No.=TVS6027PFC)

ALL DIMENSIONS IN INCHES

MAXIMUM RATINGS & ELECTRICAL CHARACTERISTICS

Ratings at 25 °C ambient temperature unless otherwise specified.

PARAMETER (TEST CONDITIONS)	SYMBOL	RATINGS		UNITS
		TVS6027PFC	TVS6027PFA	
Series Number				
Maximum Recurrent Peak Reverse Voltage	VRRM			VOLTS
Working Peak Reverse Voltage	VRWM	23	23	
Maximum DC Blocking Voltage	VDC			
Breakdown Voltage (IR = 100 mA dc, Tc = 25 °C)	V(BR)	24 Min / 32 Max	24 Min / 32 Max	
Average Forward Rectified Current	Io	60	60	AMPS
Non-repetitive Peak Forward Surge Current (Half wave, single phase, 60 Hz sine applied to rated load)	IFSM	800	800	
Repetitive Peak Reverse Surge Current (Time Constant = 10 mSec Duty Cycle ≤ 1.0%, Tc = 25 °C)	IRSM	140	140	
Instantaneous Forward Voltage (IF = 100A @ 300 μSec pulse, Tc = 25 °C)	VF	Maximum	1.05	VOLTS
		Typical	1.00	
Maximum DC Reverse Current (VR = 20V DC, Tc = 25 °C)	IR	200	200	nA
Maximum Thermal Resistance, Junction to Case (Note 1)	RθJC	0.8	0.8	°C/W
Junction Operating & Storage Temperature Range	TJ, TSTG	-65 to +175	-65 to +175	°C

Notes: 1) Single Side Cooled

3.011vs6027pf

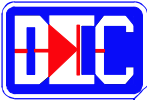

35 AMP OVERVOLTAGE TRANSIENT SUPPRESSORS

FEATURES

- PROPRIETARY **SOFT GLASS[®]** JUNCTION PASSIVATION FOR SUPERIOR RELIABILITY AND PERFORMANCE
- VOID FREE VACUUM DIE SOLDERING FOR MAXIMUM MECHANICAL STRENGTH AND HEAT DISSIPATION
- Large die for high power capability
- Very low forward voltage drop
- Increased capacity by parallel operation
- Protects expensive automotive electronics and mobile equipment

MECHANICAL SPECIFICATION

*Die Size:
0.180" x 0.180"
Square*

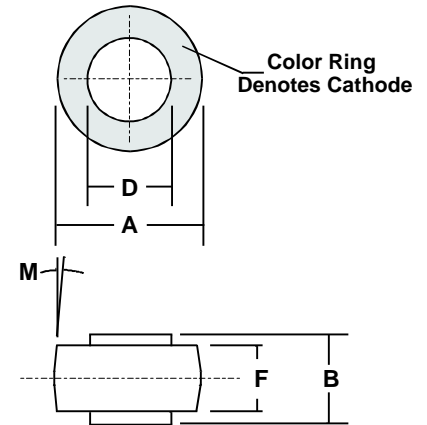

MECHANICAL DATA

- Case: Transfer molded plastic
- Finish: All external surfaces are silver plated for corrosion resistance superior solderability
- Soldering Temperature: 250 °C maximum
- Mounting Position: Any
- Polarity: Color band denotes cathode
- Weight: 0.6 Ounces (1.8 Grams)

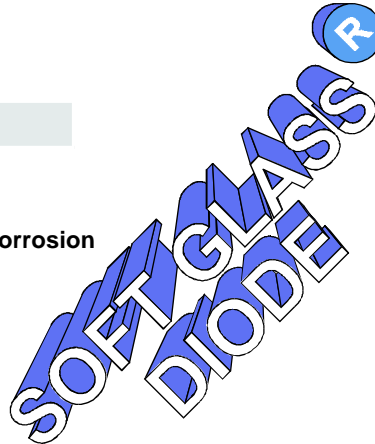

DIM	MILLIMETERS		INCHES	
	MIN	MAX	MIN	MAX
A	9.78	10.29	0.385	0.405
B	6.05	6.20	0.238	0.244
D	5.54	5.60	0.218	0.220
F	4.19	4.45	0.165	0.175
M	5° NOM		5° NOM	

MAXIMUM RATINGS & ELECTRICAL CHARACTERISTICS

Ratings at 25 °C ambient temperature unless otherwise specified.
 Single phase, half wave, 60 Hz resistive or inductive load.

PARAMETER (TEST CONDITIONS)	SYMBOL	RATINGS	UNITS
Series Number		TVS3527	
Maximum Recurrent Peak Reverse Voltage	VRRM	23	VOLTS
Working Peak Reverse Voltage	VRWM		
Maximum DC Blocking Voltage	V _{DC}		
Breakdown Voltage (I _R = 100 mA dc, T _c = 25 °C)	V(BR)	24 Min / 32 Max	
Average Forward Rectified Current	I _O	35	AMPS
Non-repetitive Peak Forward Surge Current (Half wave, single phase, 60 Hz sine applied to rated load)	I _{FSM}	600	
Repetitive Peak Reverse Surge Current (Time Constant = 10 mSec Duty Cycle ≤ 1.0%, T _c = 25 °C)	I _{RSM}	110	
Instantaneous Forward Voltage (I _F = 100A @ 300 μSec pulse, T _c = 25 °C)	V _F	1.05 1.00 (Typical)	VOLTS
Maximum DC Reverse Current (V _R = 20V DC, T _c = 25 °C)	I _R	200	nA
Maximum Thermal Resistance, Junction to Case (Note 1)	R _{θJC}	0.8	°C/W
Junction Operating & Storage Temperature Range	T _J , T _{STG}	-65 to +175	°C

Notes: 1) Single Side Cooled

3.01 11/25

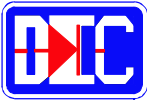

35 AMP OVERVOLTAGE TRANSIENT SUPPRESSORS

FEATURES

- PROPRIETARY **SOFT GLASS[®]** JUNCTION PASSIVATION FOR SUPERIOR RELIABILITY AND PERFORMANCE
- VOID FREE VACUUM DIE SOLDERING FOR MAXIMUM MECHANICAL STRENGTH AND HEAT DISSIPATION
- Large die for high power capability
- Very low forward voltage drop
- Increased capacity by parallel operation
- Protects expensive automotive electronics and mobile equipment

MECHANICAL SPECIFICATION

Die Size:
0.180" x 0.180"
Square

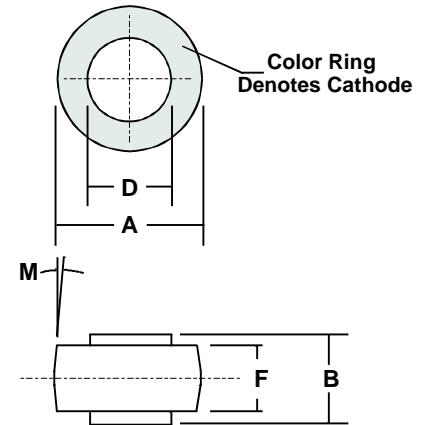

MECHANICAL DATA

- Case: Transfer molded plastic
- Finish: All external surfaces are silver plated for corrosion resistance superior solderability
- Soldering Temperature: 250 °C maximum
- Mounting Position: Any
- Polarity: Color band denotes cathode
- Weight: 0.6 Ounces (1.8 Grams)

SOFT GLASS[®]
DIODE

DIM	MILLIMETERS		INCHES	
	MIN	MAX	MIN	MAX
A	8.43	8.69	0.332	0.342
B	5.94	6.25	0.234	0.246
D	5.46	5.71	0.215	0.225
F	4.19	4.45	0.165	0.175
M	5° NOM		5° NOM	

MAXIMUM RATINGS & ELECTRICAL CHARACTERISTICS

Ratings at 25 °C ambient temperature unless otherwise specified.
 Single phase, half wave, 60 Hz resistive or inductive load.

PARAMETER (TEST CONDITIONS)	SYMBOL	RATINGS	UNITS
Series Number		TVS3527S	
Maximum Recurrent Peak Reverse Voltage	V _{RRM}	23	VOLTS
Working Peak Reverse Voltage	V _{RWM}		
Maximum DC Blocking Voltage	V _{DC}		
Breakdown Voltage (I _R = 100 mA dc, T _c = 25 °C)	V _(BR)	24 Min / 32 Max	
Average Forward Rectified Current	I _o	35	AMPS
Non-repetitive Peak Forward Surge Current (Half wave, single phase, 60 Hz sine applied to rated load)	I _{FSM}	600	
Repetitive Peak Reverse Surge Current (Time Constant = 10 mSec Duty Cycle ≤ 1.0%, T _c = 25 °C)	I _{RSM}	110	
Instantaneous Forward Voltage (I _F = 100A @ 300 μSec pulse, T _c = 25 °C)	V _F	1.05 1.00 (Typical)	VOLTS
Maximum DC Reverse Current (V _R = 20V DC, T _c = 25 °C)	I _R	200	nA
Maximum Thermal Resistance, Junction to Case (Note 1)	R _{θJC}	0.8	°C/W
Junction Operating & Storage Temperature Range	T _J , T _{STG}	-65 to +175	°C

Notes: 1) Single Side Cooled

3.011v35s

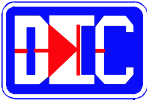

35 AMP OVERVOLTAGE TRANSIENT DISH DIODE

FEATURES

- VOID FREE VACUUM DIE SOLDERING FOR MAXIMUM MECHANICAL STRENGTH AND HEAT DISSIPATION
- PROPRIETARY *SOFT GLASS*[®] JUNCTION PASSIVATION FOR SUPERIOR RELIABILITY AND PERFORMANCE
- Large die for high power capability
- Very low forward voltage drop
- Built-in stress relief mechanism for die protection
- Silver plated substrates for corrosion resistance and superior soldeability
- Soldering temperature: 250 °C maximum
- Protects expensive automotive electronics and mobile equipment

MECHANICAL SPECIFICATION

Die Size:
 0.180" x 0.180"
 Square

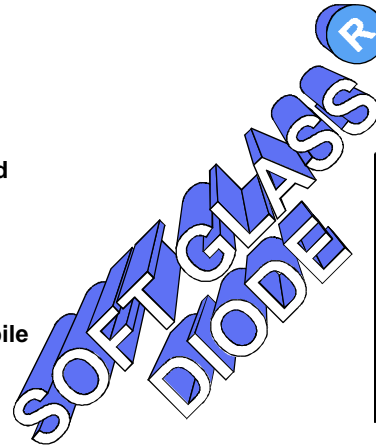
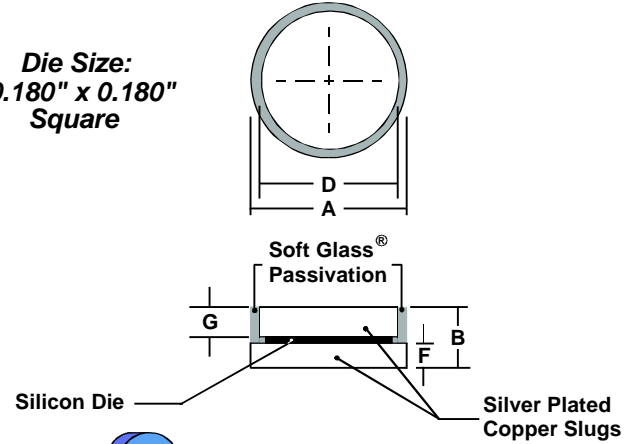

DIM	MILLIMETERS		INCHES	
	MIN	MAX	MIN	MAX
A	5.33	5.46	0.210	0.215
B	2.03	2.16	0.080	0.085
D	4.70	4.83	0.185	0.190
F	0.64	0.76	0.025	0.030
G	0.96	1.09	0.038	0.043

MAXIMUM RATINGS & ELECTRICAL CHARACTERISTICS

Ratings at 25 °C ambient temperature unless otherwise specified.

PARAMETER (TEST CONDITIONS)	SYMBOL	RATINGS	UNITS
Series Number		TVS3527D	
Maximum Recurrent Peak Reverse Voltage	V _{RRM}	23	VOLTS
Working Peak Reverse Voltage	V _{RWM}		
Maximum DC Blocking Voltage	V _{DC}		
Breakdown Voltage (I _R = 100 mA dc, T _c = 25 °C)	V _(BR)	24 Min / 32 Max	
Average Rectified Forward Current (Single phase, Resistive load, 60 Hz)	I _o	35	AMPS
Non-repetitive Peak Forward Surge Current (Half wave, Single phase, 60 Hz sine applied to rated load)	I _{FSM}	500	
Repetitive Peak Reverse Surge Current (Time constant = 10 mSec Duty cycle ≤ 1.0%, T _c = 25 °C)	I _{RSM}	110	
Instantaneous Forward Voltage (I _F = 80A @ 300 μSec pulse, T _c = 25 °C)	V _F	1.05 1.00 (Typical)	VOLTS
Maximum DC Reverse Current (V _R = 20V DC, T _c = 25 °C)	I _R	200	nA
Maximum Thermal Resistance, Junction to Lead (Note 1)	R _{θJC}	0.8	°C/W
Junction Operating & Storage Temperature Range	T _J , T _{STG}	-65 to +175	°C

Notes: 1) Single Side Cooled

3.01 tvs35d

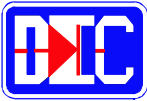

50 AMP OVERVOLTAGE TRANSIENT SUPPRESSORS

FEATURES

- PROPRIETARY **SOFT GLASS[®]** JUNCTION PASSIVATION FOR SUPERIOR RELIABILITY AND PERFORMANCE
- VOID FREE VACUUM DIE SOLDERING FOR MAXIMUM MECHANICAL STRENGTH AND HEAT DISSIPATION
- INDUSTRY'S LARGEST DIE FOR HIGHEST POWER CAPABILITY
- Very low forward voltage drop
- Increased capacity by parallel operation
- Protects expensive automotive electronics and mobile equipment

MECHANICAL SPECIFICATION

Die Size:
 0.216" Flat to Flat
 Hex

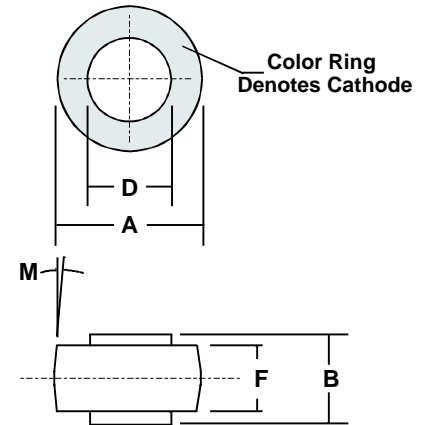

MECHANICAL DATA

- Case: Transfer molded plastic
- Finish: All external surfaces are silver plated for corrosion resistance superior solderability
- Soldering Temperature: 250 °C maximum
- Mounting Position: Any
- Polarity: Color band denotes cathode
- Weight: 0.6 Ounces (1.8 Grams)

SOFT GLASS[®]
DIODE

DIM	MILLIMETERS		INCHES	
	MIN	MAX	MIN	MAX
A	9.78	10.29	0.385	0.405
B	6.05	6.20	0.238	0.244
D	5.54	5.60	0.218	0.220
F	4.19	4.45	0.165	0.175
M	5° NOM		5° NOM	

MAXIMUM RATINGS & ELECTRICAL CHARACTERISTICS

Ratings at 25 °C ambient temperature unless otherwise specified.
 Single phase, half wave, 60 Hz resistive or inductive load.

PARAMETER (TEST CONDITIONS)	SYMBOL	RATINGS	UNITS
Series Number		TVS5027	
Maximum Recurrent Peak Reverse Voltage	VRRM	23	VOLTS
Working Peak Reverse Voltage	VRWM		
Maximum DC Blocking Voltage	V _{DC}		
Breakdown Voltage (I _R = 100 mA dc, T _c = 25 °C)	V(BR)	24 Min / 32 Max	
Average Forward Rectified Current	I _O	50	AMPS
Non-repetitive Peak Forward Surge Current (Half wave, single phase, 60 Hz sine applied to rated load)	I _{FSM}	800	
Repetitive Peak Reverse Surge Current (Time Constant = 10 mSec Duty Cycle ≤ 1.0%, T _c = 25 °C)	I _{RSM}	140	
Instantaneous Forward Voltage (I _F = 100A @ 300 μSec pulse, T _c = 25 °C)	V _F	1.05 1.00	VOLTS
Maximum DC Reverse Current (V _R = 20V DC, T _c = 25 °C)	I _R	200	nA
Maximum Thermal Resistance, Junction to Case (Note 1)	R _{θJC}	0.8	°C/W
Junction Operating & Storage Temperature Range	T _J , T _{STG}	-65 to +175	°C

Notes: 1) Single Side Cooled

1.99720-0010

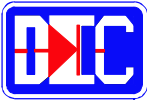

50 AMP OVERVOLTAGE TRANSIENT SUPPRESSORS

FEATURES

- PROPRIETARY **SOFT GLASS[®]** JUNCTION PASSIVATION FOR SUPERIOR RELIABILITY AND PERFORMANCE
- VOID FREE VACUUM DIE SOLDERING FOR MAXIMUM MECHANICAL STRENGTH AND HEAT DISSIPATION
- INDUSTRY'S LARGEST DIE FOR HIGHEST POWER CAPABILITY
- Very low forward voltage drop
- Increased capacity by parallel operation
- Protects expensive automotive electronics and mobile equipment

MECHANICAL SPECIFICATION

Die Size:
 0.216" Flat to Flat
 Hex

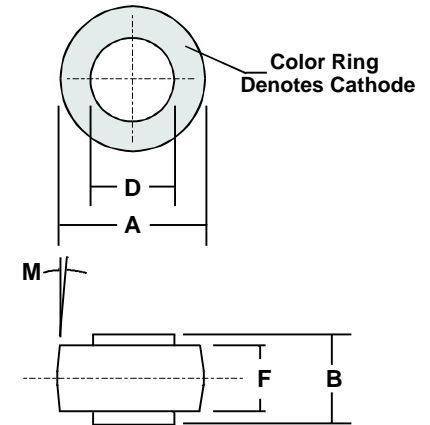

MECHANICAL DATA

- Case: Transfer molded plastic
- Finish: All external surfaces are silver plated for corrosion resistance superior solderability
- Soldering Temperature: 250 °C maximum
- Mounting Position: Any
- Polarity: Color band denotes cathode
- Weight: 0.6 Ounces (1.8 Grams)

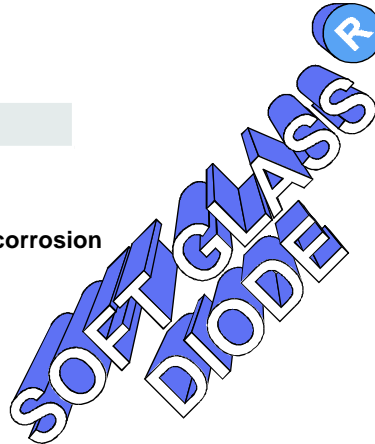

DIM	MILLIMETERS		INCHES	
	MIN	MAX	MIN	MAX
A	8.43	8.69	0.332	0.342
B	5.94	6.25	0.234	0.246
D	5.46	5.71	0.215	0.225
F	4.19	4.45	0.165	0.175
M	5° NOM		5° NOM	

MAXIMUM RATINGS & ELECTRICAL CHARACTERISTICS

Ratings at 25 °C ambient temperature unless otherwise specified.
 Single phase, half wave, 60 Hz resistive or inductive load.

PARAMETER (TEST CONDITIONS)	SYMBOL	RATINGS	UNITS
Series Number		TVS5027S	
Maximum Recurrent Peak Reverse Voltage	VRRM	23	VOLTS
Working Peak Reverse Voltage	VRWM		
Maximum DC Blocking Voltage	V _{DC}		
Breakdown Voltage (I _R = 100 mA dc, T _c = 25 °C)	V(BR)	24 Min / 32 Max	
Average Forward Rectified Current	I _o	50	AMPS
Non-repetitive Peak Forward Surge Current (Half wave, single phase, 60 Hz sine applied to rated load)	I _{FSM}	800	
Repetitive Peak Reverse Surge Current (Time Constant = 10 mSec Duty Cycle ≤ 1.0%, T _c = 25 °C)	I _{RSM}	140	
Instantaneous Forward Voltage (I _F = 100A @ 300 μSecpulse, T _c = 25°C)	V _F	1.05 1.00	VOLTS
Maximum DC Reverse Current (V _R = 20V DC, T _c = 25 °C)	I _R	200	nA
Maximum Thermal Resistance, Junction to Case (Note 1)	R _{θJC}	0.8	°C/W
Junction Operating & Storage Temperature Range	T _J , T _{STG}	-65 to +175	°C

Notes: 1) Single Side Cooled

1.997ud-0910

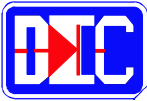

600 WATT TRANSIENT VOLTAGE SUPPRESSORS

FEATURES

- PROPRIETARY **SOFT GLASS[®]** JUNCTION PASSIVATION FOR SUPERIOR RELIABILITY AND PERFORMANCE
- VOID FREE VACUUM DIE SOLDERING FOR MAXIMUM MECHANICAL STRENGTH AND HEAT DISSIPATION
- 600 Watt peak power capability on 10/1000 μ S waveform
- Excellent clamping capability
- Repetition rate (Duty Cycle): 0.01%
- Low incremental surge resistance
- Fast response time (0 to BV Volts)

Unidirectional - typically less than 1pS

Bidirectional - typically less then 5nS

- Typical Reverse Leakage (I_D) less than 1 μ A above 10 Volts

MECHANICAL DATA

- Case: JEDEC DO-41 molded epoxy (UL Flammability Rating 94V-O)
- Terminals: Plated Axial Leads
- Soldering: Per MIL-STD 202 Method 208 guaranteed
- Mounting Position: Any
- Polarity: Color band denotes cathode
- Weight: 0.012 Ounces (0.34 Grams)

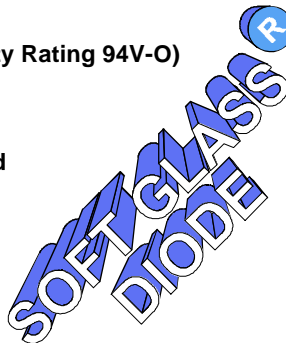

MECHANICAL SPECIFICATION

ACTUAL SIZE OF DO-41 PACKAGE

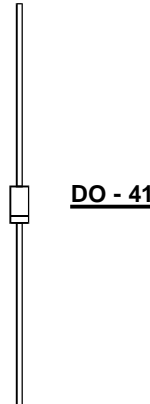

DO - 41

SERIES P6KE6.8 - P6KE400CA

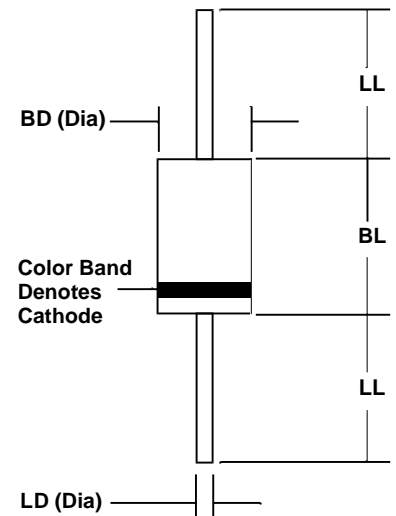

Sym	Minimum		Maximum	
	In	mm	In	mm
BL	0.160	4.1	0.205	5.2
BD	0.103	2.6	0.107	2.7
LL	1.00	25.4		
LD	0.028	0.71	0.034	0.86

MAXIMUM RATINGS & ELECTRICAL CHARACTERISTICS

Ratings at 25 °C ambient temperature unless otherwise specified. Resistive or inductive load.

PARAMETER (TEST CONDITIONS)	SYMBOL	RATINGS	UNITS
Peak Pulse Power Dissipation on 10/1000 μ S Waveform (Note 1, Fig 1)	PPPM	Minimum 600	WATTS
Peak Pulse Current on 10/1000mS Waveform (Note 1, Fig 1)	IPPM	See Table 1	AMPS
Steady State Power Dissipation at $T_L = 75$ °C With Lead Length = 0.375" (9.5mm) (Note 2)	PM(AV)	5.0	WATTS
Peak Forward Surge Current (8.3mS Single Half Sine Wave Superimposed on Rated Load - JEDEC Method) Unidirectional Only. (Note 2)	IFSM	100	AMPS
Maximum Instantaneous Forward Voltage at 50A; Unidirectional Only (Note 2)	V _F	3.5	VOLTS
Junction Operating & Storage Temperature Range	T _J , T _{STG}	-65 to +175	°C/W

Notes:

- 1) Non-Repetitive Current Pulse Per Fig. 3 and Derated Above $T_A = 25$ °C Per Fig 2.
- 2) Mounted on Copper Leaf Area of 1.58 in² (40mm²) Per Fig 5.
- 3) 8.3mS Single Half Sine Wave or Equivalent Square Wave. Duty Cycle = 4 Pulses Per Minute Maximum.

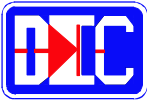

600 WATT TRANSIENT VOLTAGE SUPPRESSORS

RATINGS AND CHARACTERISTIC CURVES FOR SERIES P6KE6.8 - P6KE400CA

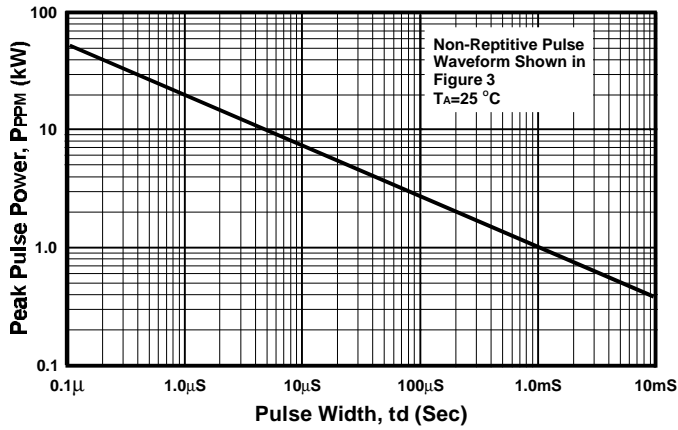

FIGURE 1. PEAK PULSE POWER RATING CURVE

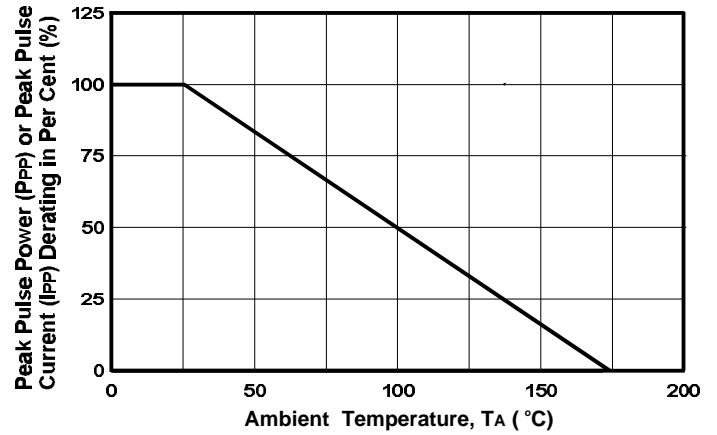

FIGURE 2. PULSE DERATING CURVE

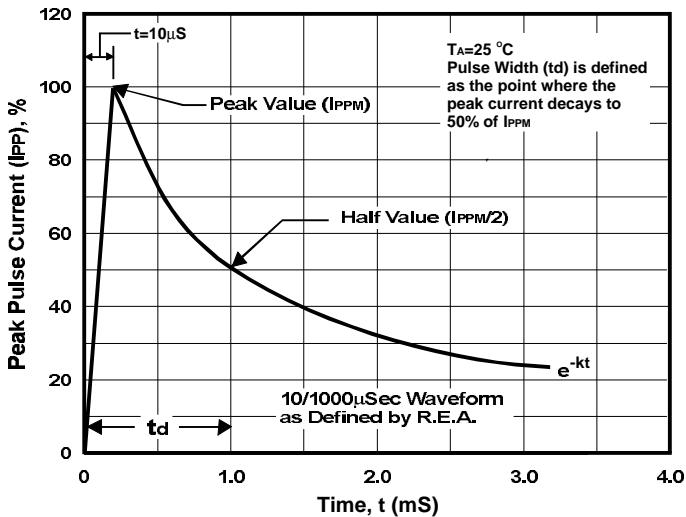

FIGURE 3. PULSE WAVEFORM

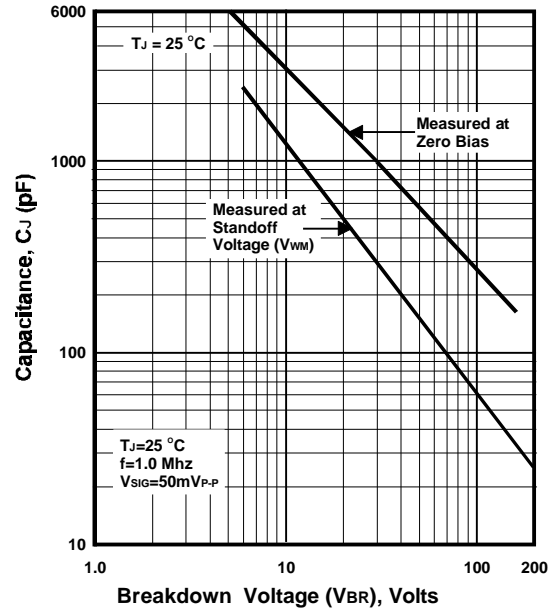

FIGURE 4. TYPICAL JUNCTION CAPACITANCE-UNIDIRECTIONAL

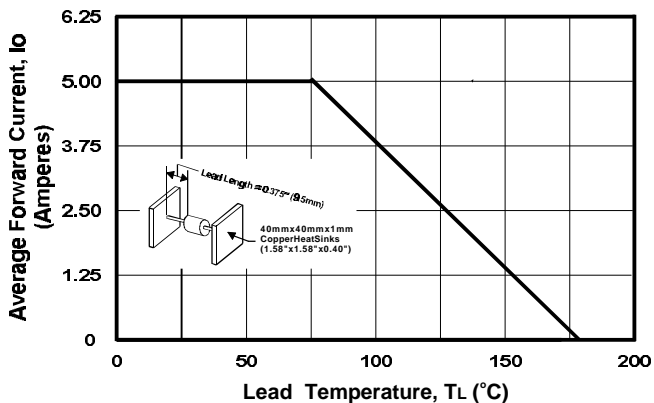

FIGURE 5. STEADY STATE POWER DERATING CURVE

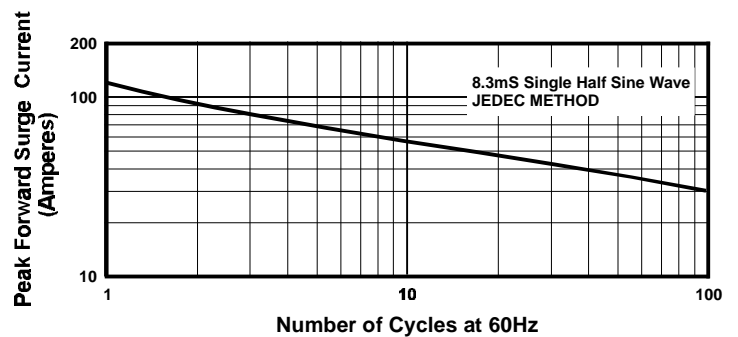
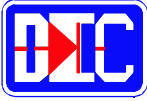

FIGURE 6. MAXIMUM NON-REPETITIVE PEAK FORWARD SURGE CURRENT - UNIDIRECTIONAL



600 WATT TRANSIENT VOLTAGE SUPPRESSORS

RATINGS AND CHARACTERISTIC CURVES FOR SERIES P6KE6.8 - P6KE400CA

FOR BIDIRECTIONAL APPLICATIONS: USE "C" OR "CA" FOR TYPES P6KE6.8-PKE440. FOR EXAMPLE: P6KE6.8C OR P6KE400CA.
 ELECTRICAL CHARACTERISTICS APPLY IN BOTH DIRECTIONS.

PART NO.	BREAKDOWN VOLTAGE (V _{BR}) (NOTE 1)			V _{WM} (VOLTS)	MAX. I _D @ V _{WM} (μA) (Note 3)	MAX. I _{PPM} (AMPS) (Note 2)	V _C @ I _{PPM} (VOLTS)	MAX. TEMPERATURE COEFFICIENT OF V _{BR} (% °C)
	VOLTS		@ I _T (mA)					
	MIN	MAX						
P6KE6.8	6.12	7.48	10	5.50	1000	56	10.8	0.057
P6KE6.8A	6.45	7.14	10	5.80	1000	57	10.5	0.057
P6KE7.5	6.75	8.25	10	6.05	500	51	11.7	0.061
P6KE7.5A	7.13	7.88	10	6.40	500	53	11.3	0.061
P6KE8.2	7.38	9.02	10	6.63	200	48	12.5	0.065
P6KE8.2A	7.79	8.61	10	7.02	200	50	12.1	0.065
P6KE9.1	8.19	10.0	1.0	7.37	50	44	13.8	0.068
P6KE9.1A	8.65	9.55	1.0	7.78	50	45	13.4	0.068
P6KE10	9.00	11.0	1.0	8.10	10	40	15.0	0.073
P6KE10A	9.50	10.5	1.0	8.55	10	41	14.5	0.073
P6KE11	9.90	12.1	1.0	8.92	5.0	37	16.2	0.075
P6KE11A	10.5	11.6	1.0	9.40	5.0	38	15.6	0.075
P6KE12	10.8	13.2	1.0	9.72	5.0	35	17.3	0.078
P6KE12A	11.4	12.6	1.0	10.2	5.0	36	16.7	0.078
P6KE13	11.7	14.3	1.0	10.5	5.0	32	19.0	0.061
P6KE13A	12.4	13.7	1.0	11.1	5.0	33	18.2	0.081
P6KE15	13.5	16.5	1.0	12.1	5.0	27	22.0	0.084
P6KE15A	14.3	15.8	1.0	12.8	5.0	28	21.2	0.084
P6KE16	14.4	17.6	1.0	12.9	5.0	26	23.5	0.086
P6KE16A	15.2	16.8	1.0	13.6	5.0	27	22.5	0.086
P6KE18	16.2	19.8	1.0	14.5	5.0	23	26.5	0.088
P6KE18A	17.1	18.9	1.0	15.3	5.0	24	25.2	0.088
P6KE20	18.0	22.0	1.0	16.2	5.0	21	29.1	0.090
P6KE20A	19.0	21.0	1.0	17.1	5.0	22	27.7	0.090
P6KE22	19.8	24.2	1.0	17.8	5.0	19	31.9	0.092
P6KE22A	20.9	23.1	1.0	18.8	5.0	20	30.6	0.092
P6KE24	21.6	26.4	1.0	19.4	5.0	17	34.7	0.094
P6KE24A	22.8	25.2	1.0	20.5	5.0	18	33.2	0.094
P6KE27	24.3	29.7	1.0	21.8	5.0	15	39.1	0.096
P6KE27A	25.7	28.4	1.0	23.1	5.0	16	37.5	0.096
P6KE30	27.0	33.0	1.0	24.3	5.0	14	43.5	0.097
P6KE30A	28.5	31.5	1.0	25.6	5.0	14.4	41.4	0.097
P6KE33	29.7	36.3	1.0	26.8	5.0	12.6	47.7	0.098
P6KE33A	31.4	34.7	1.0	28.2	5.0	13.2	45.7	0.098
P6KE36	32.4	39.6	1.0	29.1	5.0	11.6	52.0	0.099
P6KE36A	34.2	37.8	1.0	30.8	5.0	12.0	49.9	0.099
P6KE39	35.1	42.9	1.0	31.6	5.0	10.6	56.4	0.100
P6KE39A	37.1	41.0	1.0	33.3	5.0	11.2	53.9	0.100
P6KE43	38.7	47.3	1.0	34.8	5.0	9.6	61.9	0.101
P6KE43A	40.9	45.2	1.0	36.8	5.0	10.1	59.3	0.101
P6KE47	42.3	51.7	1.0	38.1	5.0	8.9	67.8	0.101
P6KE47A	44.7	49.4	1.0	40.2	5.0	9.3	64.8	0.101

Table Symbols:

1. V_{BR} measured after I_T applied for 300μS, I_T=square wave pulse or equivalent
2. Surge current waveform per Figure 3 and derate per Figure 2.
3. For Bidirectional types with V_R of 10 Volts and less, the I_T limit is doubled
4. All Terms and Symbols are consistent with ANSI/IEEE C62.35

- I_D - Reverse Leakage Current
- IPPM - Maximum Peak Pulse Current
- I_T - Test Current (To Determine V_{BR})
- mA - Milliamperes
- Max. - Maximum
- Min - Minimum
- V_{BR} - Breakdown Voltage
- V_C - Clamping Voltage
- V_{WM} - Reverse Standoff Voltage
- % - Per Cent
- °C - Degrees Celsius

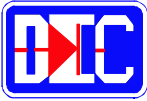

600 WATT TRANSIENT VOLTAGE SUPPRESSORS

RATINGS AND CHARACTERISTIC CURVES FOR SERIES P6KE6.8 - P6KE400CA

FOR BIDIRECTIONAL APPLICATIONS: USE "C" OR "CA" FOR TYPES P6KE6.8-PKE440. FOR EXAMPLE: P6KE6.8C OR P6KE400CA.
 ELECTRICAL CHARACTERISTICS APPLY IN BOTH DIRECTIONS.

PART NO.	BREAKDOWN VOLTAGE (V _{BR}) (NOTE 1)			V _{WM} (VOLTS)	MAX. I _D @ V _{WM} (μA) (Note 3)	MAX. I _{PPM} (AMPS) (Note 2)	V _C @ I _{PPM} (VOLTS)	MAX. TEMPERATURE COEFFICIENT OF V _{BR} (% °C)
	VOLTS		@ I _T (mA)					
	MIN	MAX						
P6KE51	45.9	56.1	1.0	41.3	5.0	8.2	73.5	0.102
P6KE51A	48.5	53.6	1.0	43.6	5.0	8.6	70.1	0.102
P6KE56	50.4	61.6	1.0	45.4	5.0	7.4	80.5	0.103
P6KE56A	53.2	58.8	1.0	47.8	5.0	7.8	77.0	0.103
P6KE62	55.8	68.2	1.0	50.2	5.0	6.8	89.0	0.104
P6KE62A	58.9	65.1	1.0	53.0	5.0	7.1	85.0	0.104
P6KE68	61.2	74.8	1.0	55.1	5.0	6.1	98.0	0.104
P6KE68A	64.6	71.4	1.0	58.1	5.0	6.5	92.0	0.104
P6KE75	67.5	82.5	1.0	60.7	5.0	5.5	108	0.105
P6KE75A	71.3	78.8	1.0	64.1	5.0	5.8	103	0.105
P6KE82	73.8	90.2	1.0	66.4	5.0	5.1	118	0.105
P6KE82A	77.9	86.1	1.0	70.1	5.0	5.3	113	0.105
P6KE91	81.9	100	1.0	73.7	5.0	4.5	131	0.106
P6KE91A	86.5	95.5	1.0	77.8	5.0	4.8	125	0.106
P6KE100	90.0	110	1.0	81.0	5.0	4.2	144	0.106
P6KE100A	95.0	105	1.0	85.5	5.0	4.4	137	0.106
P6KE110	99.0	121	1.0	89.2	5.0	3.8	158	0.107
P6KE110A	105	116	1.0	94.0	5.0	4.0	152	0.107
P6KE120	108	132	1.0	97.2	5.0	3.5	173	0.107
P6KE120A	114	126	1.0	102	5.0	3.6	165	0.107
P6KE130	117	143	1.0	105	5.0	3.2	187	0.107
P6KE130A	124	137	1.0	111	5.0	3.3	179	0.107
P6KE150	135	165	1.0	121	5.0	2.8	215	0.108
P6KE150A	143	158	1.0	128	5.0	2.9	207	0.108
P6KE160	144	176	1.0	130	5.0	2.6	230	0.108
P6KE160A	152	168	1.0	136	5.0	2.7	219	0.108
P6KE170	153	187	1.0	138	5.0	2.5	244	0.108
P6KE170A	162	179	1.0	145	5.0	2.6	234	0.108
P6KE180	162	198	1.0	146	5.0	2.3	258	0.108
P6KE180A	171	189	1.0	154	5.0	2.4	246	0.108
P6KE200	180	220	1.0	162	5.0	2.1	287	0.108
P6KE200A	190	210	1.0	171	5.0	2.2	274	0.108
P6KE220	198	242	1.0	175	5.0	1.75	344	0.108
P6KE220A	209	231	1.0	185	5.0	1.83	328	0.108
P6KE250	225	275	1.0	202	5.0	1.67	360	0.110
P6KE250A	237	263	1.0	214	5.0	1.75	344	0.110
P6KE300	270	330	1.0	243	5.0	1.40	430	0.110
P6KE300A	285	315	1.0	256	5.0	1.45	414	0.110
P6KE350	315	385	1.0	284	5.0	1.20	504	0.110
P6KE350A	332	368	1.0	300	5.0	1.25	482	0.110
P6KE400	360	440	1.0	324	5.0	1.05	574	0.110
P6KE400A	380	420	1.0	342	5.0	1.10	548	0.110
P6KE440	396	484	1.0	356	5.0	0.95	631	0.110
P6KE440A	418	462	1.0	376	5.0	1.00	602	0.110

Table Symbols:

1. V_{BR} measured after I_T applied for 300μS, I_T=square wave pulse or equivalent
2. Surge current waveform per Figure 3 and derate per Figure 2.
3. For Bidirectional types with V_R of 10 Volts and less, the I_R limit is doubled
4. All Terms and Symbols are consistent with ANS/IEEE C62.35

I_D - Reverse Leakage Current
 I_{PPM} - Maximum Peak Pulse Current
 I_T - Test Current (To Determine V_{BR})
 mA - Milliampere
 Max. - Maximum
 Min - Minimum

V_{BR} - Breakdown Voltage
 V_C - Clamping Voltage
 V_{WM} - Reverse Standoff Voltage
 % - Per Cent
 °C - Degrees Celsius

SECTION K
AUTOMOTIVE DIODES
STANDARD DIODES

MOLDED PRODUCTS

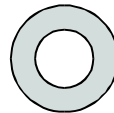

DIODE CELLS





12 AMP PR4 DIODE CELLS

FEATURES

- PROPRIETARY **SOFT GLASS[®]** JUNCTION PASSIVATION FOR SUPERIOR RELIABILITY AND PERFORMANCE
- VOID FREE VACUUM DIE SOLDERING FOR MAXIMUM MECHANICAL STRENGTH AND HEAT DISSIPATION (Solder Voids: Typical < 2%, Max. < 10% of Die Area)
- Large die for high power capability
- Very low forward voltage drop
- Built-in stress relief mechanism for die protection
- Silver plated substrates for easy soldering or installation
- Soldering temperature: 250 °C maximum
- Protects expensive automotive electronics and mobile equipment

SOFT GLASS[®] DIODE

MECHANICAL SPECIFICATION

Die Size:
0.120"
Round

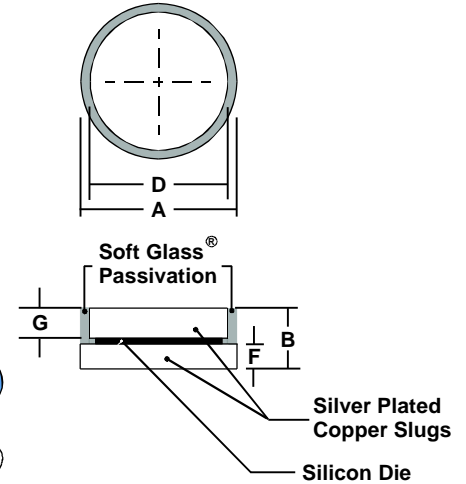

DIM	MILLIMETERS		INCHES	
	MIN	MAX	MIN	MAX
A	3.86	4.06	0.152	0.160
B	1.98	2.18	0.078	0.086
D	3.07	3.28	0.121	0.129
F	0.76 Typ		0.030 Typ	
G	1.02 Typ		0.040 Typ	

MAXIMUM RATINGS & ELECTRICAL CHARACTERISTICS

Ratings at 25 °C ambient temperature unless otherwise specified.

PARAMETER (TEST CONDITIONS)	SYMBOL	RATINGS							UNITS
		BAR 1200D	BAR 1201D	BAR 1202D	BAR 1204D	BAR 1206D	BAR 1208D	BAR 1210D	
Series Number									
Maximum Recurrent Peak Reverse Voltage	VRRM	50	100	200	400	600	800	1000	VOLTS
Working Peak Reverse Voltage	VRWM								
Maximum DC Blocking Voltage	VDC								
Non-repetitive Peak Reverse Voltage (Half wave, Single phase, 60Hz peak)	VRSM	60	120	240	480	720	960	1200	
Average Rectified Forward Current (Single phase, Resistive load, 60Hz)	I _o	12							AMPS
Non-repetitive Peak Forward Surge Current (Half wave, Single phase, 60Hz sine applied to rated load)	I _{FSM}	250							
Maximum Instantaneous Forward Voltage @ I _F = 3 Amps @ I _F = 12 Amps	V _F	0.90			0.95		1.10		VOLTS
Maximum DC Reverse Current At Rated DC Blocking Voltage @ T _c = 25 °C	I _R	0.5							μA
Operating & Storage Temperature Range	T _J , T _{STG}	-65 to +175							°C



25 AMP SOZA DIODE CELLS

FEATURES

- PROPRIETARY **SOFT GLASS[®]** JUNCTION PASSIVATION FOR SUPERIOR RELIABILITY AND PERFORMANCE
- VOID FREE VACUUM DIE SOLDERING FOR MAXIMUM MECHANICAL STRENGTH AND HEAT DISSIPATION (Solder Voids: Typical < 2%, Max. < 10% of Die Area)
- Large die for high power capability
- Very low forward voltage drop
- Built-in stress relief mechanism for die protection
- Silver plated substrates for easy soldering or installation
- Soldering temperature: 250 °C maximum
- Protects expensive automotive electronics and mobile equipment

SOFT GLASS[®] DIODE

Die Size:
0.180"
Round

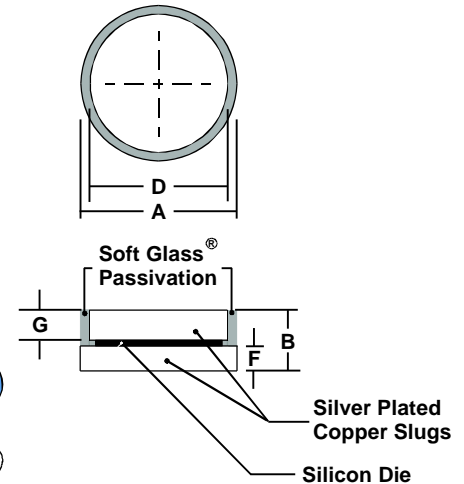

DIM	MILLIMETERS		INCHES	
	MIN	MAX	MIN	MAX
A	5.36	5.56	0.211	0.219
B	1.98	2.18	0.078	0.086
D	4.72	4.93	0.186	0.194
F	0.76 Typ		0.030 Typ	
G	1.02 Typ		0.040 Typ	

MAXIMUM RATINGS & ELECTRICAL CHARACTERISTICS

Ratings at 25 °C ambient temperature unless otherwise specified.

PARAMETER (TEST CONDITIONS)	SYMBOL	RATINGS							UNITS
		BAR 2500D	BAR 2501D	BAR 2502D	BAR 2504D	BAR 2506D	BAR 2508D	BAR 2510D	
Series Number									
Maximum Recurrent Peak Reverse Voltage	VRRM								VOLTS
Working Peak Reverse Voltage	VRWM	50	100	200	400	600	800	1000	
Maximum DC Blocking Voltage	VDC								
Non-repetitive Peak Reverse Voltage (Half wave, Single phase, 60Hz peak)	VRSM	60	120	240	480	720	960	1200	AMPS
Average Rectified Forward Current (Single phase, Resistive load, 60Hz)	I _o	25							
Non-repetitive Peak Forward Surge Current (Half wave, Single phase, 60Hz sine applied to rated load)	I _{FSM}	500							
Maximum Instantaneous Forward Voltage @ I _F = 6 Amps @ I _F = 25 Amps	V _F	0.85			0.90				VOLTS
		1.05			1.10				
Maximum DC Reverse Current At Rated DC Blocking Voltage @ T _c = 25 °C	I _R	0.5							μA
Operating & Storage Temperature Range	T _J , T _{STG}	-65 to +175							°C

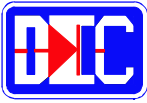

35 AMP BUTTON DIODES

FEATURES

- PROPRIETARY **SOFT GLASS[®]** JUNCTION PASSIVATION FOR SUPERIOR RELIABILITY AND PERFORMANCE
- VOID FREE VACUUM DIE SOLDERING FOR MAXIMUM MECHANICAL STRENGTH AND HEAT DISSIPATION (Solder Voids: Typical < 2%, Max. < 10% of Die Area)
- Compact molded design
- High surge current, 600 A @ $T_J = 175^\circ\text{C}$
- Low cost
- Peak performance at elevated temperatures: 35 A @ $T_J = 175^\circ\text{C}$

MECHANICAL SPECIFICATION

Die Size:
 0.165" x 0.165"
 Square

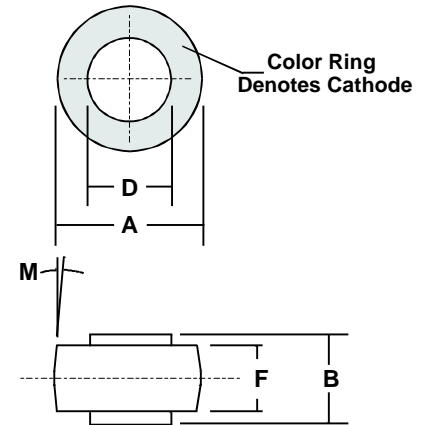

MECHANICAL DATA

- Case: Transfer molded plastic
- Finish: All external surfaces are silver plated for corrosion resistance and superior solderability
- Soldering Temperature: 250 °C maximum
- Mounting Position: Any
- Polarity: Color band denotes cathode
- Weight: 0.6 Ounces (1.8 Grams)

SOFT GLASS[®]
DIODE

DIM	MILLIMETERS		INCHES	
	MIN	MAX	MIN	MAX
A	9.78	10.29	0.385	0.405
B	5.97	6.35	0.235	0.250
D	5.46	5.71	0.215	0.225
F	4.19	4.45	0.165	0.175
M	5° NOM		5° NOM	

MAXIMUM RATINGS & ELECTRICAL CHARACTERISTICS

Ratings at 25 °C ambient temperature unless otherwise specified.

PARAMETER (TEST CONDITIONS)	SYMBOL	RATINGS								UNITS
		BAR 3500	BAR 3501	BAR 3502	BAR 3504	BAR 3506	BAR 3508	BAR 3510		
Series Number										
Maximum DC Blocking Voltage	V _{RRM}									VOLTS
Maximum RMS Voltage	V _{RWM}	50	100	200	400	600	800	1000		
Maximum Peak Recurrent Reverse Voltage	V _{DC}									
Non-repetitive Peak Reverse Voltage (Half wave, single phase, 60 Hz peak)	V _{RSM}	60	120	240	480	720	960	1200		
Average Forward Rectified Current @ T _c = 150 °C	I _O	35								AMPS
Peak Forward Surge Current (8.3mS single half sine wave superimposed on rated load)	I _{FSM}	600								
Repetitive Peak Reverse Surge Current (Half wave, single phase, 60 Hz applied to rated load)	I _{RSM}	110								
Maximum Forward Voltage Drop at 35 Amp DC	V _{FM}	1.1 (Typical 0.95)				1.2				VOLTS
Maximum Average DC Reverse Current @ T _A = 25 °C	I _{RM}	1								μA
At Rated DC Blocking Voltage @ T _A = 100 °C		50								
Maximum Thermal Resistance, Junction to Case (Note 1)	R _{θJC}	0.9								°C/W
Junction Operating and Storage Temperature Range	T _J , T _{STG}	-65 to +175								°C

Notes: 1) Single Side Cooled

BAR35

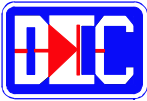

35 AMP BUTTON DIODES

FEATURES

- PROPRIETARY **SOFT GLASS[®]** JUNCTION PASSIVATION FOR SUPERIOR RELIABILITY AND PERFORMANCE
- VOID FREE VACUUM DIE SOLDERING FOR MAXIMUM MECHANICAL STRENGTH AND HEAT DISSIPATION (Solder Voids: Typical < 2%, Max. < 10% of Die Area)
- Compact molded design
- High surge current, 600 A @ $T_J = 175^\circ\text{C}$
- Low cost
- Peak performance at elevated temperatures: 35 A @ $T_J = 175^\circ\text{C}$

MECHANICAL SPECIFICATION

Die Size:
 0.165" x 0.165"
 Square

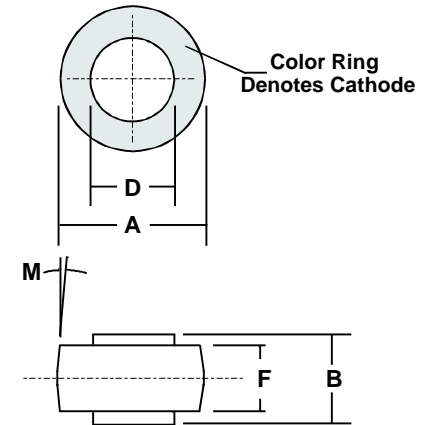

MECHANICAL DATA

- Case: Transfer molded plastic
- Finish: All external surfaces are corrosion resistant and the contact areas are readily solderable
- Soldering Temperature: 250 °C maximum
- Mounting Position: Any
- Polarity: Color band denotes cathode
- Weight: 0.6 Ounces (1.8 Grams)

SOFT GLASS[®]
 DIODE

DIM	MILLIMETERS		INCHES	
	MIN	MAX	MIN	MAX
A	8.43	8.69	0.332	0.342
B	5.94	6.25	0.234	0.246
D	5.46	5.71	0.215	0.225
F	4.19	4.45	0.165	0.175
M	5° NOM		5° NOM	

MAXIMUM RATINGS & ELECTRICAL CHARACTERISTICS

Ratings at 25 °C ambient temperature unless otherwise specified.

PARAMETER (TEST CONDITIONS)	SYMBOL	RATINGS							UNITS
		BAR 3500S	BAR 3501S	BAR 3502S	BAR 3504S	BAR 3506S	BAR 3508S	BAR 3510S	
Series Number									
Maximum DC Blocking Voltage	V _{RRM}								VOLTS
Maximum RMS Voltage	V _{RWM}	50	100	200	400	600	800	1000	
Maximum Peak Recurrent Reverse Voltage	V _{DC}								
Non-repetitive Peak Reverse Voltage (Half wave, single phase, 60 Hz peak)	V _{RSM}	60	120	240	480	720	960	1200	
Average Forward Rectified Current @ T _c =150 °C	I _O	35							AMPS
Peak Forward Surge Current (8.3mS single half sine wave superimposed on rated load)	I _{FSM}	600							
Repetitive Peak Reverse Surge Current (Half wave, single phase, 60 Hz applied to rated load)	I _{RSM}	110							
Maximum Forward Voltage Drop at 35 Amp DC	V _{FM}	1.1 (Typical 0.95)					1.2		VOLTS
Maximum Average DC Reverse Current @ T _A = 25 °C	I _{RM}	1							μA
At Rated DC Blocking Voltage @ T _A = 100 °C		50							
Maximum Thermal Resistance, Junction to Case (Note 1)	R _{θJC}	0.9							°C/W
Junction Operating and Storage Temperature Range	T _J , T _{STG}	-65 to +175							°C

Notes: 1) Single Side Cooled

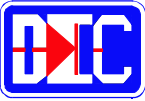

35 AMP JUMBO DIODE CELLS

FEATURES

- PROPRIETARY **SOFT GLASS[®]** JUNCTION PASSIVATION FOR SUPERIOR RELIABILITY AND PERFORMANCE
- VOID FREE VACUUM DIE SOLDERING FOR MAXIMUM MECHANICAL STRENGTH AND HEAT DISSIPATION (Solder Voids: Typical < 2%, Max. < 10% of Die Area)
- Large die for high power capability
- Very low forward voltage drop
- Built-in stress relief mechanism for die protection
- Silver plated substrates for easy soldering or installation
- Soldering temperature: 250 °C maximum
- Protects expensive automotive electronics and mobile equipment

SOFT GLASS[®] DIODE

*Die Size:
0.165" x 0.165"
Square*

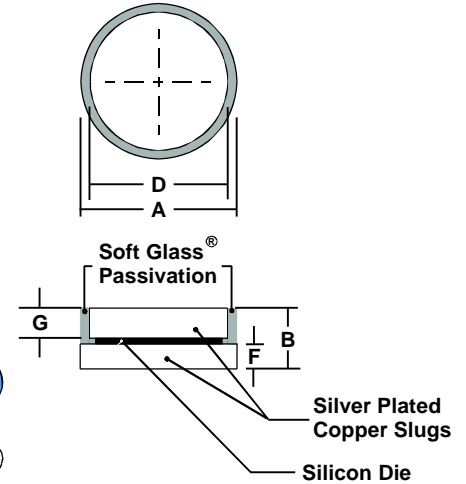

DIM	MILLIMETERS		INCHES	
	MIN	MAX	MIN	MAX
A	5.33	5.46	0.210	0.215
B	2.03	2.16	0.080	0.085
D	4.70	4.83	0.185	0.190
F	0.64	0.76	0.025	0.030
G	0.96	1.09	0.038	0.043

MAXIMUM RATINGS & ELECTRICAL CHARACTERISTICS

Ratings at 25 °C ambient temperature unless otherwise specified.

PARAMETER (TEST CONDITIONS)	SYMBOL	RATINGS								UNITS
		BAR 3500D	BAR 3501D	BAR 3502D	BAR 3504D	BAR 3506D	BAR 3508D	BAR 3510D		
Series Number										
Maximum Recurrent Peak Reverse Voltage	VRRM									VOLTS
Working Peak Reverse Voltage	VRWM	50	100	200	400	600	800	1000		
Maximum DC Blocking Voltage	VDC									
Non-repetitive Peak Reverse Voltage (Half wave, Single phase, 60Hz peak)	VRSM	60	120	240	480	720	960	1200		
Average Rectified Forward Current (Single phase, Resistive load, 60Hz)	I _o	35								AMPS
Non-repetitive Peak Forward Surge Current (Half wave, Single phase, 60Hz sine applied to rated load)	IFSM	600								
Repetitive Peak Reverse Surge Current (Time constant = 10 mSec, Duty cycle ≤ 1.0%, Tc = 25 °C)	IRSM	110								
Maximum Instantaneous Forward Voltage (I _F = 80A @300 μSec pulse, Tc = 25 °C)	V _F	1.1 (1.05 Typical)					1.2			VOLTS
Maximum DC Reverse Current @ Tc = 25 °C At Rated DC Blocking Voltage @ Tc = 100 °C	I _R	0.5					50			μA
Maximum Thermal Resistance, Junction to Lead (Note 1)	R _{θJC}	0.9								°C/W
Operating & Storage Temperature Range	T _J , T _{STG}	-65 to +175								°C

Notes: 1) Single Side Cooled

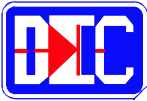

50 AMP BUTTON DIODES

FEATURES

- PROPRIETARY **SOFT GLASS[®]** JUNCTION PASSIVATION FOR SUPERIOR RELIABILITY AND PERFORMANCE
- VOID FREE VACUUM DIE SOLDERING FOR MAXIMUM MECHANICAL STRENGTH AND HEAT DISSIPATION (Solder Voids: Typical < 2%, Max. < 10% of Die Area)
- Compact molded design
- High surge current, 720 A @ $T_J = 175^\circ\text{C}$
- Low cost
- Peak performance at elevated temperatures: 50 A @ $T_J = 175^\circ\text{C}$

MECHANICAL SPECIFICATION

Die Size:
 0.180" x 0.180"
 Square

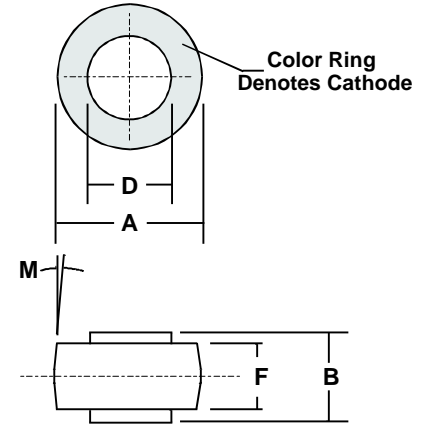

MECHANICAL DATA

- Case: Transfer molded plastic
- Finish: All external surfaces are corrosion resistant and the contact areas are readily solderable
- Soldering Temperature: 250 °C maximum
- Mounting Position: Any
- Polarity: Color band denotes cathode
- Weight: 0.6 Ounces (1.8 Grams)

SOFT GLASS[®]
DIODE

DIM	MILLIMETERS		INCHES	
	MIN	MAX	MIN	MAX
A	9.78	10.29	0.385	0.405
B	6.05	6.20	0.238	0.244
D	5.54	6.60	0.218	0.220
F	4.19	4.45	0.165	0.175
M	5° NOM		5° NOM	

MAXIMUM RATINGS & ELECTRICAL CHARACTERISTICS

Ratings at 25 °C ambient temperature unless otherwise specified.

PARAMETER (TEST CONDITIONS)	SYMBOL	RATINGS								UNITS
		BAR 5000	BAR 5001	BAR 5002	BAR 5004	BAR 5006	BAR 5008	BAR 5010		
Series Number										
Maximum DC Blocking Voltage	V _{RRM}									VOLTS
Maximum RMS Voltage	V _{RWM}	50	100	200	400	600	800	1000		
Maximum Peak Recurrent Reverse Voltage	V _{DC}									
Non-repetitive Peak Reverse Voltage (Half wave, single phase, 60 Hz peak)	V _{RSM}	60	120	240	480	720	960	1200		
Average Forward Rectified Current @ T _c =125 °C	I _O	50								AMPS
Peak Forward Surge Current (8.3mS single half sine wave superimposed on rated load)	I _{FSM}	720								
Repetitive Peak Reverse Surge Current (Half wave, single phase, 60 Hz applied to rated load)	I _{RSM}	120								
Maximum Forward Voltage Drop at 50 Amp DC	V _{FM}	1.1 (Typical 0.95)					1.2			VOLTS
Maximum Average DC Reverse Current @ T _A = 25 °C	I _{RM}	1								μA
At Rated DC Blocking Voltage @ T _A = 100 °C		50								
Maximum Thermal Resistance, Junction to Case (Note 1)	R _{θJC}	0.8								°C/W
Junction Operating and Storage Temperature Range	T _J , T _{STG}	-65 to +175								°C

Notes: 1) Single Side Cooled

BAR50

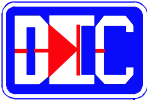

50 AMP BUTTON DIODES

FEATURES

- PROPRIETARY **SOFT GLASS[®]** JUNCTION PASSIVATION FOR SUPERIOR RELIABILITY AND PERFORMANCE
- VOID FREE VACUUM DIE SOLDERING FOR MAXIMUM MECHANICAL STRENGTH AND HEAT DISSIPATION (Solder Voids: Typical < 2%, Max. < 10% of Die Area)
- Compact molded design
- High surge current, 720 A @ $T_J = 175^\circ\text{C}$
- Low cost
- Peak performance at elevated temperatures: 50 A @ $T_J = 175^\circ\text{C}$

MECHANICAL SPECIFICATION

Die Size:
0.180" x 0.180"
Square

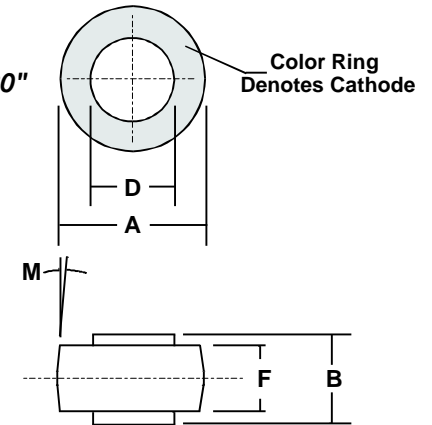

MECHANICAL DATA

- Case: Transfer molded plastic
- Finish: All external surfaces are corrosion resistant and the contact areas are readily solderable
- Soldering Temperature: 250 °C maximum
- Mounting Position: Any
- Polarity: Color band denotes cathode
- Weight: 0.6 Ounces (1.8 Grams)

SOFT GLASS[®]
DIODE

DIM	MILLIMETERS		INCHES	
	MIN	MAX	MIN	MAX
A	8.43	8.69	0.332	0.342
B	5.94	6.25	0.234	0.246
D	5.46	5.71	0.215	0.225
F	4.19	4.45	0.165	0.175
M	5° NOM		5° NOM	

MAXIMUM RATINGS & ELECTRICAL CHARACTERISTICS

Ratings at 25 °C ambient temperature unless otherwise specified.

PARAMETER (TEST CONDITIONS)	SYMBOL	RATINGS							UNITS
		BAR 5000S	BAR 5001S	BAR 5002S	BAR 5004S	BAR 5006S	BAR 5008S	BAR 5010S	
Series Number									
Maximum DC Blocking Voltage	V _{RRM}								VOLTS
Maximum RMS Voltage	V _{RWM}	50	100	200	400	600	800	1000	
Maximum Peak Recurrent Reverse Voltage	V _{DC}								
Non-repetitive Peak Reverse Voltage (Half wave, single phase, 60 Hz peak)	V _{RSM}	60	120	240	480	720	960	1200	
Average Forward Rectified Current @ T _c =125 °C	I _O	50							AMPS
Peak Forward Surge Current (8.3mS single half sine wave superimposed on rated load)	I _{FSM}	720							
Repetitive Peak Reverse Surge Current (Half wave, single phase, 60 Hz applied to rated load)	I _{RSM}	120							
Maximum Forward Voltage Drop at 100 Amp DC	V _{FM}	1.1 (Typical 1.05)					1.2		VOLTS
Maximum Average DC Reverse Current @ T _A = 25 °C	I _{RM}	1							μA
At Rated DC Blocking Voltage @ T _A = 100 °C		50							
Maximum Thermal Resistance, Junction to Case (Note 1)	R _{θJC}	0.8							°C/W
Junction Operating and Storage Temperature Range	T _J , T _{STG}	-65 to +175							°C

Notes: 1) Single Side Cooled

BAR50s

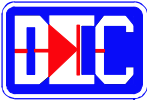

50 AMP JUMBO DIODE CELL

FEATURES

- PROPRIETARY **SOFT GLASS[®]** JUNCTION PASSIVATION FOR SUPERIOR RELIABILITY AND PERFORMANCE
- VOID FREE VACUUM DIE SOLDERING FOR MAXIMUM MECHANICAL STRENGTH AND HEAT DISSIPATION (Solder Voids: Typical < 2%, Max. < 10% of Die Area)
- Large die for high power capability
- Very low forward voltage drop
- Built-in stress relief mechanism for die protection
- Silver plated substrates for easy soldering or installation
- Soldering temperature: 250 °C maximum
- Protects expensive automotive electronics and mobile equipment

SOFT GLASS[®] DIODE

MECHANICAL SPECIFICATION

Die Size:
 0.180" x 0.180"
 Square

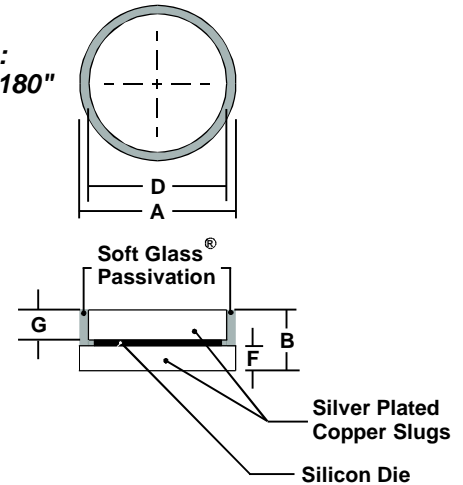

DIM	MILLIMETERS		INCHES	
	MIN	MAX	MIN	MAX
A	7.25	7.35	0.285	0.290
B	2.05	2.15	0.080	0.085
D	6.50	6.60	0.256	0.260
F	0.72	0.82	0.028	0.032
G	0.96	1.07	0.038	0.042

MAXIMUM RATINGS & ELECTRICAL CHARACTERISTICS

Ratings at 25 °C ambient temperature unless otherwise specified.

PARAMETER (TEST CONDITIONS)	SYMBOL	RATINGS							UNITS
		BAR 5000D	BAR 5001D	BAR 5002D	BAR 5004D	BAR 5006D	BAR 5008D	BAR 5010D	
Series Number									
Maximum DC Blocking Voltage	VRRM								VOLTS
Maximum RMS Voltage	VRWM	50	100	200	400	600	800	1000	
Maximum Peak Recurrent Reverse Voltage	VDC								
Non-repetitive Peak Reverse Voltage (Half wave, single phase, 60 Hz peak)	VRSM	60	120	240	480	720	960	1200	
Average Forward Rectified Current @ Tc=125 °C	IO	50							AMPS
Peak Forward Surge Current (8.3mS single half sine wave superimposed on rated load)	IFSM	720							
Repetitive Peak Reverse Surge Current (Half wave, single phase, 60 Hz applied to rated load)	IRSM	120							
Maximum Instantaneous Forward Voltage Drop (IF=100A @ 300 μ Sec Pulse, Tc=25 °C)	VFM	1.1 (1.05 Typical)					1.2		VOLTS
Maximum Average DC Reverse Current @ TA = 25 °C	IRM	2							μA
At Rated DC Blocking Voltage @ TA = 125 °C		50							
Maximum Thermal Resistance, Junction to Case (Note 1)	RθJC	0.8							°C/W
Junction Operating and Storage Temperature Range	TJ, TSTG	-65 to +175							°C

Notes: 1) Single Side Cooled

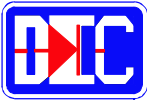

60 AMP BUTTON DIODES

FEATURES

- PROPRIETARY **SOFT GLASS®** JUNCTION PASSIVATION FOR SUPERIOR RELIABILITY AND PERFORMANCE
- VOID FREE VACUUM DIE SOLDERING FOR MAXIMUM MECHANICAL STRENGTH AND HEAT DISSIPATION (Solder Voids: Typical < 2%, Max. < 10% of Die Area)
- Compact molded design
- High surge current, 800 A @ $T_J = 175^\circ\text{C}$
- Low cost
- Peak performance at elevated temperatures: 60 A @ $T_J = 150^\circ\text{C}$

MECHANICAL SPECIFICATION

*Die Size:
0.216" Flat to Flat
Hex*

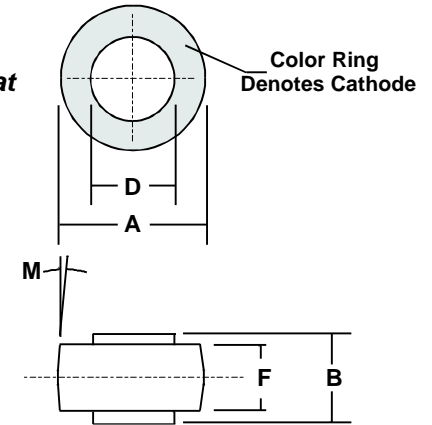

MECHANICAL DATA

- Case: Transfer molded plastic
- Finish: All external surfaces are corrosion resistant and the contact areas are readily solderable
- Soldering Temperature: 250 °C maximum
- Mounting Position: Any
- Polarity: Color band denotes cathode
- Weight: 0.6 Ounces (1.8 Grams)

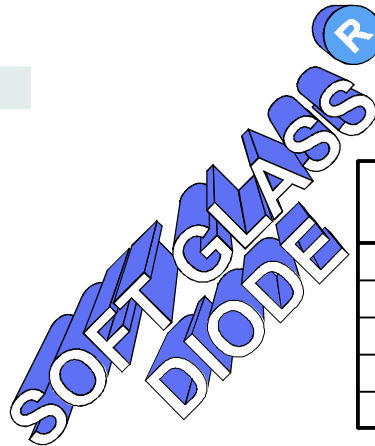

DIM	MILLIMETERS		INCHES	
	MIN	MAX	MIN	MAX
A	9.78	10.29	0.385	0.405
B	6.05	6.20	0.238	0.244
D	5.54	6.60	0.218	0.220
F	4.19	4.45	0.165	0.175
M	5° NOM		5° NOM	

MAXIMUM RATINGS & ELECTRICAL CHARACTERISTICS

Ratings at 25 °C ambient temperature unless otherwise specified.

PARAMETER (TEST CONDITIONS)	SYMBOL	RATINGS							UNITS
		BAR 6000	BAR 6001	BAR 6002	BAR 6004	BAR 6006	BAR 6008	BAR 6010	
Series Number									
Maximum DC Blocking Voltage	VRRM								VOLTS
Maximum RMS Voltage	VRWM	50	100	200	400	600	800	1000	
Maximum Peak Recurrent Reverse Voltage	VDC								
Non-repetitive Peak Reverse Voltage (Half wave, single phase, 60 Hz peak)	VRSM	60	120	240	480	720	960	1200	
Average Forward Rectified Current @ $T_c=125^\circ\text{C}$	I _O	60							AMPS
Peak Forward Surge Current (8.3mS single half sine wave superimposed on rated load)	I _{FSM}	800							
Repetitive Peak Reverse Surge Current (Half wave, single phase, 60 Hz applied to rated load)	I _{RSM}	140							
Maximum Instantaneous Forward Voltage Drop (I _F =100A @ 300 μSec Pulse, T _C =25 °C)	V _{FM}	1.06 (1.03 Typical)					1.10		VOLTS
Maximum Average DC Reverse Current @ T _A = 25 °C	I _{RM}	1							μA
At Rated DC Blocking Voltage @ T _A = 125 °C		50							
Maximum Thermal Resistance, Junction to Case (Note 1)	R _{θJC}	0.8							°C/W
Junction Operating and Storage Temperature Range	T _J , T _{STG}	-65 to +175							°C

Notes: 1) Single Side Cooled

BAR60

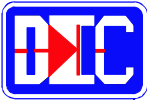

60 AMP BUTTON DIODES

FEATURES

- PROPRIETARY **SOFT GLASS[®]** JUNCTION PASSIVATION FOR SUPERIOR RELIABILITY AND PERFORMANCE
- VOID FREE VACUUM DIE SOLDERING FOR MAXIMUM MECHANICAL STRENGTH AND HEAT DISSIPATION (Solder Voids: Typical < 2%, Max. < 10% of Die Area)
- Compact molded design
- High surge current, 800 A @ $T_J = 175^\circ\text{C}$
- Low cost
- Peak performance at elevated temperatures: 60 A @ $T_J = 150^\circ\text{C}$

MECHANICAL SPECIFICATION

Die Size:
 0.216" Flat to Flat
 Hex

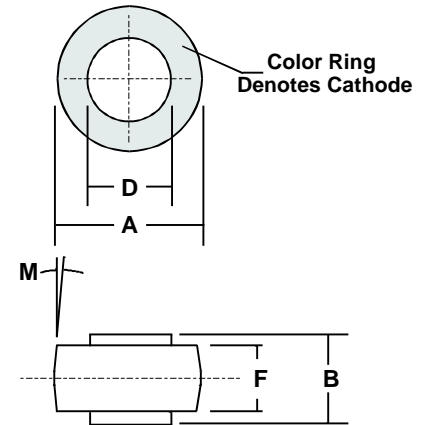

MECHANICAL DATA

- Case: Transfer molded plastic
- Finish: All external surfaces are corrosion resistant and the contact areas are readily solderable
- Soldering Temperature: 250 °C maximum
- Mounting Position: Any
- Polarity: Color band denotes cathode
- Weight: 0.6 Ounces (1.8 Grams)

SOFT GLASS[®] DIODE

DIM	MILLIMETERS		INCHES	
	MIN	MAX	MIN	MAX
A	8.43	8.69	0.332	0.342
B	5.94	6.25	0.234	0.246
D	5.46	5.71	0.215	0.225
F	4.19	4.45	0.165	0.175
M	5° NOM		5° NOM	

MAXIMUM RATINGS & ELECTRICAL CHARACTERISTICS

Ratings at 25 °C ambient temperature unless otherwise specified.

PARAMETER (TEST CONDITIONS)	SYMBOL	RATINGS							UNITS
		BAR 6000S	BAR 6001S	BAR 6002S	BAR 6004S	BAR 6006S	BAR 6008S	BAR 6010S	
Series Number									
Maximum DC Blocking Voltage	V _{RRM}								VOLTS
Maximum RMS Voltage	V _{RWM}	50	100	200	400	600	800	1000	
Maximum Peak Recurrent Reverse Voltage	V _{DC}								
Non-repetitive Peak Reverse Voltage (Half wave, single phase, 60 Hz peak)	V _{RSM}	60	120	240	480	720	960	1200	
Average Forward Rectified Current @ T _c =125 °C	I _O	60							AMPS
Peak Forward Surge Current (8.3mS single half sine wave superimposed on rated load)	I _{FSM}	800							
Repetitive Peak Reverse Surge Current (Half wave, single phase, 60 Hz applied to rated load)	I _{RSM}	140							
Maximum Instantaneous Forward Voltage Drop (I _F =100A @ 300 μSec Pulse, T _C =25 °C)	V _{FM}	1.06 (1.03 Typical)				1.10			VOLTS
Maximum Average DC Reverse Current @ T _A = 25 °C	I _{RM}	1							μA
At Rated DC Blocking Voltage @ T _A = 125 °C		50							
Maximum Thermal Resistance, Junction to Case (Note 1)	R _{θJC}	0.8							°C/W
Junction Operating and Storage Temperature Range	T _J , T _{STG}	-65 to +175							°C

Notes: 1) Single Side Cooled

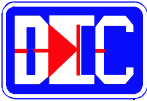

60 AMP BUTTON DIODES

FEATURES

- PROPRIETARY **SOFT GLASS[®]** JUNCTION PASSIVATION FOR SUPERIOR RELIABILITY AND PERFORMANCE
- VOID FREE VACUUM DIE SOLDERING FOR MAXIMUM MECHANICAL STRENGTH AND HEAT DISSIPATION (Solder Voids: Typical < 2%, Max. < 10% of Die Area)
- Compact molded design
- High surge current, 800 A @ $T_J = 175^\circ\text{C}$
- Low cost
- Peak performance at elevated temperatures: 60 A @ $T_J = 150^\circ\text{C}$

MECHANICAL SPECIFICATION

Die Size:
 0.216" Flat to Flat
 Hex

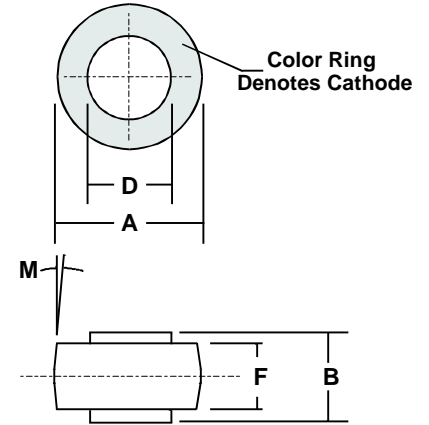

MECHANICAL DATA

- Case: Transfer molded plastic
- Finish: All external surfaces are corrosion resistant and the contact areas are readily solderable
- Soldering Temperature: 250 °C maximum
- Mounting Position: Any
- Polarity: Color band denotes cathode
- Weight: 0.6 Ounces (1.8 Grams)

SOFT GLASS[®] DIODE

DIM	MILLIMETERS		INCHES	
	MIN	MAX	MIN	MAX
A	8.43	8.69	0.332	0.342
B	5.94	6.25	0.234	0.246
D	5.46	5.71	0.215	0.225
F	4.19	4.45	0.165	0.175
M	5° NOM		5° NOM	

MAXIMUM RATINGS & ELECTRICAL CHARACTERISTICS

Ratings at 25 °C ambient temperature unless otherwise specified.

PARAMETER (TEST CONDITIONS)	SYMBOL	RATINGS							UNITS
		BAR 6000S	BAR 6001S	BAR 6002S	BAR 6004S	BAR 6006S	BAR 6008S	BAR 6010S	
Series Number									
Maximum DC Blocking Voltage	V _{RRM}								VOLTS
Maximum RMS Voltage	V _{RWM}	50	100	200	400	600	800	1000	
Maximum Peak Recurrent Reverse Voltage	V _{DC}								
Non-repetitive Peak Reverse Voltage (Half wave, single phase, 60 Hz peak)	V _{RSM}	60	120	240	480	720	960	1200	
Average Forward Rectified Current @ T _c =125 °C	I _O	60							AMPS
Peak Forward Surge Current (8.3mS single half sine wave superimposed on rated load)	I _{FSM}	800							
Repetitive Peak Reverse Surge Current (Half wave, single phase, 60 Hz applied to rated load)	I _{RSM}	140							
Maximum Instantaneous Forward Voltage Drop (I _F =100A @ 300 μ Sec Pulse, T _C =25 °C)	V _{FM}	1.06 (1.03 Typical)				1.10			VOLTS
Maximum Average DC Reverse Current @ T _A = 25 °C	I _{RM}	1							μA
At Rated DC Blocking Voltage @ T _A = 125 °C		50							
Maximum Thermal Resistance, Junction to Case (Note 1)	R _{θJC}	0.8							°C/W
Junction Operating and Storage Temperature Range	T _J , T _{STG}	-65 to +175							°C

Notes: 1) Single Side Cooled

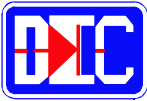

75 AMP BUTTON DIODES

FEATURES

- PROPRIETARY **SOFT GLASS[®]** JUNCTION PASSIVATION FOR SUPERIOR RELIABILITY AND PERFORMANCE
- VOID FREE VACUUM DIE SOLDERING FOR MAXIMUM MECHANICAL STRENGTH AND HEAT DISSIPATION (Solder Voids: Typical < 2%, Max. < 10% of Die Area)
- Compact molded design
- High surge current, 800 A @ $T_J = 175^\circ\text{C}$
- Low cost
- Peak performance at elevated temperatures: 75 A @ $T_J = 150^\circ\text{C}$

MECHANICAL SPECIFICATION

Die Size:
0.250" Diameter
Round

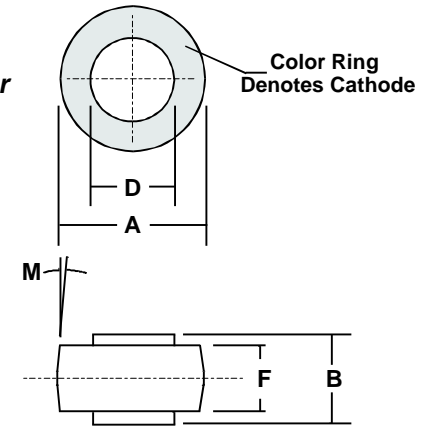

MECHANICAL DATA

- Case: Transfer molded plastic
- Finish: All external surfaces are corrosion resistant and the contact areas are readily solderable
- Soldering Temperature: 250 °C maximum
- Mounting Position: Any
- Polarity: Color band denotes cathode
- Weight: 0.6 Ounces (1.8 Grams)

SOFT GLASS[®]
DIODE

DIM	MILLIMETERS		INCHES	
	MIN	MAX	MIN	MAX
A	9.78	10.29	0.385	0.405
B	6.05	6.20	0.238	0.244
D	5.54	6.60	0.218	0.220
F	4.19	4.45	0.165	0.175
M	5° NOM		5° NOM	

MAXIMUM RATINGS & ELECTRICAL CHARACTERISTICS

Ratings at 25 °C ambient temperature unless otherwise specified.

PARAMETER (TEST CONDITIONS)	SYMBOL	RATINGS							UNITS
		BAR 7500	BAR 7501	BAR 7502	BAR 7504	BAR 7506	BAR 7508	BAR 7510	
Series Number									
Maximum DC Blocking Voltage	VRRM								VOLTS
Maximum RMS Voltage	VRWM	50	100	200	400	600	800	1000	
Maximum Peak Recurrent Reverse Voltage	VDC								
Non-repetitive Peak Reverse Voltage (Half wave, single phase, 60 Hz peak)	VRSM	60	120	240	480	720	960	1200	
Average Forward Rectified Current @ $T_c=150^\circ\text{C}$	I _O	75							AMPS
Peak Forward Surge Current (8.3mS single half sine wave superimposed on rated load)	I _{FSM}	800							
Repetitive Peak Reverse Surge Current (Half wave, single phase, 60 Hz applied to rated load)	I _{RSM}	140							
Maximum Forward Voltage Drop at 100 Amp DC	V _{FM}	1.05 (Typical <1.0)					1.1		VOLTS
Maximum Average DC Reverse Current @ $T_A = 25^\circ\text{C}$ At Rated DC Blocking Voltage @ $T_A = 100^\circ\text{C}$	I _{RM}	1 50							μA
Maximum Thermal Resistance, Junction to Case (Note 1)	R _{θJC}	0.8							°C/W
Junction Operating and Storage Temperature Range	T _J , T _{STG}	-65 to +175							°C

Notes: 1) Single Side Cooled

BARTS

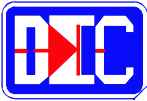

75 AMP BUTTON DIODES

FEATURES

- PROPRIETARY **SOFT GLASS[®]** JUNCTION PASSIVATION FOR SUPERIOR RELIABILITY AND PERFORMANCE
- VOID FREE VACUUM DIE SOLDERING FOR MAXIMUM MECHANICAL STRENGTH AND HEAT DISSIPATION (Solder Voids: Typical < 2%, Max. < 10% of Die Area)
- Compact molded design
- High surge current, 800 A @ $T_J = 175^\circ\text{C}$
- Low cost
- Peak performance at elevated temperatures: 75 A @ $T_J = 150^\circ\text{C}$

MECHANICAL SPECIFICATION

Die Size:
0.250" Diameter
Round

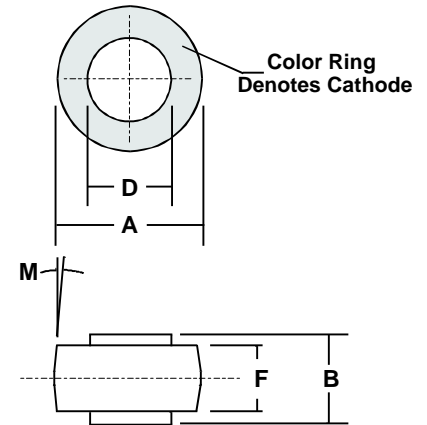

MECHANICAL DATA

- Case: Transfer molded plastic
- Finish: All external surfaces are corrosion resistant and the contact areas are readily solderable
- Soldering Temperature: 250 °C maximum
- Mounting Position: Any
- Polarity: Color band denotes cathode
- Weight: 0.6 Ounces (1.8 Grams)

SOFT GLASS[®]
DIODE

DIM	MILLIMETERS		INCHES	
	MIN	MAX	MIN	MAX
A	8.43	8.69	0.332	0.342
B	5.94	6.25	0.234	0.246
D	5.46	5.71	0.215	0.225
F	4.19	4.45	0.165	0.175
M	5° NOM		5° NOM	

MAXIMUM RATINGS & ELECTRICAL CHARACTERISTICS

Ratings at 25 °C ambient temperature unless otherwise specified.

PARAMETER (TEST CONDITIONS)	SYMBOL	RATINGS								UNITS
		BAR 7500S	BAR 7501S	BAR 7502S	BAR 7504S	BAR 7506S	BAR 7508S	BAR 7510S		
Series Number										
Maximum DC Blocking Voltage	V _{RRM}									VOLTS
Maximum RMS Voltage	V _{RWM}	50	100	200	400	600	800	1000		
Maximum Peak Recurrent Reverse Voltage	V _{DC}									
Non-repetitive Peak Reverse Voltage (Half wave, single phase, 60 Hz peak)	V _{RSM}	60	120	240	480	720	960	1200		
Average Forward Rectified Current @ T _c =150 °C	I _O	75								AMPS
Peak Forward Surge Current (8.3mS single half sine wave superimposed on rated load)	I _{FSM}	800								
Repetitive Peak Reverse Surge Current (Half wave, single phase, 60 Hz applied to rated load)	I _{RSM}	140								
Maximum Forward Voltage Drop at 100 Amp DC	V _{FM}	1.05 (Typical < 1.0)					1.1			VOLTS
Maximum Average DC Reverse Current @ T _A = 25 °C	I _{RM}	1								μA
At Rated DC Blocking Voltage @ T _A = 100 °C		50								
Maximum Thermal Resistance, Junction to Case (Note 1)	R _{θJC}	0.8								°C/W
Junction Operating and Storage Temperature Range	T _J , T _{STG}	-65 to +175								°C

Notes: 1) Single Side Cooled

BAR75S

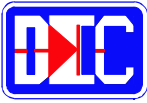

75 AMP JUMBO DIODE CELL

FEATURES

- PROPRIETARY **SOFT GLASS[®]** JUNCTION PASSIVATION FOR SUPERIOR RELIABILITY AND PERFORMANCE
- VOID FREE VACUUM DIE SOLDERING FOR MAXIMUM MECHANICAL STRENGTH AND HEAT DISSIPATION (Solder Voids: Typical < 2%, Max. < 10% of Die Area)
- Large die for high power capability
- Very low forward voltage drop
- Built-in stress relief mechanism for die protection
- Silver plated substrates for easy soldering or installation
- Soldering temperature: 250 °C maximum
- Protects expensive automotive electronics and mobile equipment

SOFT GLASS[®] DIODE

Die Size:
 0.250" Diameter
 Round die

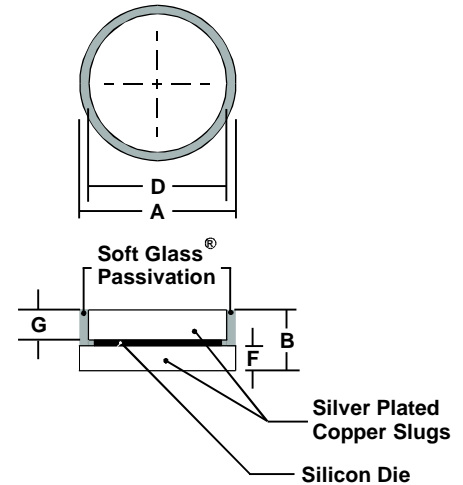

DIM	MILLIMETERS		INCHES	
	MIN	MAX	MIN	MAX
A	7.25	7.35	0.285	0.290
B	2.05	2.15	0.080	0.085
D	6.50	6.60	0.256	0.260
F	0.72	0.82	0.028	0.032
G	0.96	1.07	0.038	0.042

MAXIMUM RATINGS & ELECTRICAL CHARACTERISTICS

Ratings at 25 °C ambient temperature unless otherwise specified.

PARAMETER (TEST CONDITIONS)	SYMBOL	RATINGS							UNITS
		BAR 7500D	BAR 7501D	BAR 7502D	BAR 7504D	BAR 7506D	BAR 7508D	BAR 7510D	
Series Number									
Maximum DC Blocking Voltage	VRRM								VOLTS
Maximum RMS Voltage	VRWM	50	100	200	400	600	800	1000	
Maximum Peak Recurrent Reverse Voltage	VDC								
Non-repetitive Peak Reverse Voltage (Half wave, single phase, 60 Hz peak)	VRSM	60	120	240	480	720	960	1200	
Average Forward Rectified Current @ Tc=125 °C	IO	75							AMPS
Peak Forward Surge Current (8.3mS single half sine wave superimposed on rated load)	IFSM	800							
Repetitive Peak Reverse Surge Current (Half wave, single phase, 60 Hz applied to rated load)	IRSM	140							
Maximum Instantaneous Forward Voltage Drop (IF=100A @ 300 μ Sec Pulse, Tc=25 °C)	VFM	1.05 (1.00 Typical)					1.10		VOLTS
Maximum Average DC Reverse Current @ TA = 25 °C	IRM	2							μA
At Rated DC Blocking Voltage @ TA = 125 °C		50							
Maximum Thermal Resistance, Junction to Case (Note 1)	RθJC	0.8							°C/W
Junction Operating and Storage Temperature Range	TJ, TSTG	-65 to +175							°C

Notes: 1) Single Side Cooled

APPENDICES

PACKAGING INFORMATION

CROSS REFERENCES

ACRONYMS, ABBREVIATIONS, AND SYMBOLS

ALPHA-NUMERIC PRODUCT INDEX

SAMPLE REQUEST FORM

SOFT GLASS DIODE[®]

APPENDIX I - PACKAGING INFORMATION

TAPE AND REEL PACKAGING (AXIAL LEAD DIODES)

DIODE PACKAGE	COMPONENT SPACING FIG 1. "A" Inches (mm)	TAPE SPACING FIG 1. "B" Inches (mm)	REEL DIAMETER FIG 2. "C" Inches (mm)	QUANTITY		CARTON DIMENSIONS Inches (mm)	CARTON GROSS WEIGHT Lbs (Kgs)
				PER REEL	PER CARTON		
DO-41/DT-41	0.200 (5)	0.395 (10)	12.82 (326)	5,000	20,000	14 x 14 x 14 (355 x 355 x 355)	22.0 (10.5)
DO-15/DT-15	0.200 (5)	0.395 (10)	12.82 (326)	3,500	14,000		19.0 (8.5)
DO-27/DT-27	0.395 (10)	0.395 (10)	12.82 (326)	1,250	5,000		21.0 (9.4)
G-6	0.395 (10)	0.395 (10)	12.82 (326)	600	2,400		16.5 (7.5)

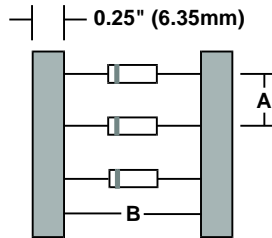

FIGURE 1

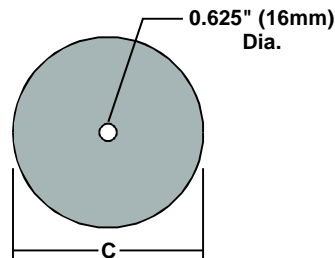

FIGURE 2

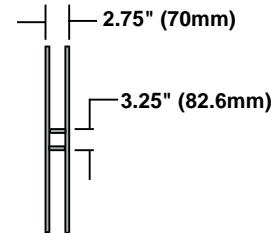

FIGURE 3

BULK PACKAGING

AXIAL LEAD DIODES

PACKAGE	BOX SIZE Inches	CARTON SIZE Inches	QUANTITY		GROSS WEIGHT, Lbs (Kgs)	
			PER BOX	PER CARTON	PER BOX	PER CARTON
DO-41/DT-41	7.88 x 3.31 x 0.94	17.25 x 8.75 x 10.00	1,000	40,000	0.825 (0.37)	43.0 (19.5)
DO-15/DT-15	7.88 x 3.31 x 0.94	17.25 x 8.75 x 10.00	1,500	40,000	1.030 (0.48)	43.0 (19.5)
DO-27/DT-27	12.00 x 3.00 x 1.56	16.50 x 12.25 x 11.25	500	15,000	1.438 (0.65)	44.0 (20.0)
G-6	12.00 x 3.00 x 1.56	16.50 x 12.25 x 11.25	400	12,000	1.500 (0.68)	44.0 (20.0)

BRIDGE RECTIFIERS

WB	12.00 x 4.25 x 3.75	20.0 x 10.0 x 10.0	1,000	10,000	2.50 (1.14)	25.0 (11.4)
SB2	8.50 x 8.50 x 2.12	17.0 x 9.0 x 10.0	400	4,000	2.80 (1.40)	28.0 (15.0)
KBL	12.50 x 6.50 x 0.50	13.5 x 13.5 x 8.0	50 (Tray)	2,000	5.12 (2.35)	39.6 (18.0)
SB4	12.50 x 6.50 x 0.50	13.5 x 13.5 x 8.0	54 (Tray)	2,160	2.87 (1.30)	39.6 (18.0)
SB5	9.50 x 5.50 x 2.50	17.0 x 9.0 x 10.0	100	1,000	3.00 (1.36)	30.0 (13.6)
SBU6	12.50 x 6.50 x 0.50	13.5 x 13.5 x 8.0	50 (Tray)	2,000	2.87 (1.30)	39.6 (18.0)
DB6	7.62 x 7.62 x 1.56	13.5 x 13.5 x 14.0	200	2,000	2.96 (1.48)	29.6 (14.8)
DB8	9.00 x 9.00 x 1.90	17.0 x 9.0 x 10.0	50	500	2.10 (0.96)	21.0 (9.6)
DB25/T	7.62 x 7.62 x 1.56	17.0 x 9.0 x 10.0	50	500	4.00 (1.82)	40.0 (18.2)
DB25/W	7.62 x 7.62 x 1.56	17.0 x 9.0 x 10.0	50	500	4.00 (1.82)	40.0 (18.2)
DB25P/T	7.62 x 7.62 x 1.56	17.0 x 9.0 x 10.0	50	500	2.70 (1.23)	27.0 (12.3)
DB25P/W	7.62 x 7.62 x 1.56	17.0 x 9.0 x 10.0	50	500	2.50 (1.14)	25.0 (11.4)
SDB	7.62 x 7.62 x 1.56	17.0 x 9.0 x 10.0	72	720	3.90 (1.77)	39.0 (17.7)

ANTI-STATIC TUBE PACKAGING

PACKAGE	BOX SIZE Length - Inches	CARTON SIZE Inches	QUANTITY		GROSS WEIGHT, Lbs (Kgs)	
			PER TUBE	PER CARTON	PER TUBE	PER CARTON
DI (BRIDGE)	19.2	24 x 6 x 6	50	2,500	0.28 (0.13)	14.1 (6.4)
SINB (BRIDGE)	19.2	24 x 6 x 6	50	2,500	0.28 (0.13)	14.1 (6.4)
TO-220AB	20.5	24 x 6 x 6	50	2,500	0.28 (0.13)	14.1 (6.4)
TO-220AC	20.5	24 x 6 x 6	50	2,500	0.28 (0.13)	14.1 (6.4)
TO-247 AB	16.0	24 x 6 x 6	25	1,250	0.41 (0.19)	20.5 (9.5)
TO-247 AC	16.0	24 x 6 x 6	25	1,250	0.41 (0.19)	20.5 (9.5)

APPENDIX II - SCHOTTKY BARRIER RECTIFIER CROSS REFERENCE

INDUSTRY PART NO.	SUGGESTED DIOTEC REPLACEMENT PART NO.	PAGE NO.	INDUSTRY PART NO.	SUGGESTED DIOTEC REPLACEMENT PART NO.	PAGE NO.	INDUSTRY PART NO.	SUGGESTED DIOTEC REPLACEMENT PART NO.	PAGE NO.	INDUSTRY PART NO.	SUGGESTED DIOTEC REPLACEMENT PART NO.	PAGE NO.
1N5817	1N5817	A1	NST545	6SK50	A11	SD180	SK108	A3	USD320C	SK3040C	B9
1N5818	1N5818	A1	NST1020	12SK40	A13	SD315	SK302	A7	USD335C	SK3040C	B9
1N5819	1N5819	A1	NST1030	12SK40	A13	SD320	SK302	A7	USD345C	SK3050C	B9
1N5820	1N5820	A5	NST1045	12SK50	A13	SD330	SK304	A7	USD620	6SK40	A11
1N5821	1N5821	A5	NST1625	16SK40	A15	SD340	SK304	A7	USD620C	SK1240C	B1
1N5822	1N5822	A5	NST1635	16SK40	A15	SD350	SK306	A7	USD635	6SK40	A11
1N5823	SK502	A9	NST1645	16SK50	A15	SD360	SK306	A7	USD635C	SK1240C	B1
1N5824	SK504	A9	NST2025	16SK50	A15	SD380	SK310	A7	USD640	6SK40	A11
1N5825	SK504	A9	NST2035	16SK50	A15	SD520	SK502	A9	USD640C	SK1240C	B1
IMBR1035	12SK40	A13	NST2045	16SK50	A15	SD530	SK504	A9	USD645	6SK50	A11
IMBR1045	12SK50	A13	NST2525	SK2440C	B5	SD540	SK504	A9	USD645C	SK1250C	B1
IMBR1050	12SK50	A13	NST2535	SK2440C	B5	SDS1620L	16SK40	A15	USD720	12SK40	A13
IMBR1060	12SK60	A13	NST3020	SK1640C	B3	SDS1630L	16SK40	A15	USD720C	SK1640C	B3
IMBR1090	12SK100	A13	NST3030	SK1640C	B3	SDS1640L	16SK40	A15	USD735	12SK40	A13
IMBR10100	12SK100	A13	NST3045	SK1650C	B3	SDS1645L	16SK50	A15	USD735C	SK1640C	B3
IMBR150	SK106	A3	SB020	SK102	A3	SR102	SK102	A3	USD740	12SK40	A13
IMBR1535CT	SK1640C	B3	SB030	SK104	A3	SR103	SK104	A3	USD740C	SK1640C	B3
IMBR1540CT	SK1640C	B3	SB040	SK104	A3	SR104	SK104	A3	USD745	12SK50	A13
IMBR1545CT	SK1650C	B3	SB120	SK102	A3	SR105	SK106	A3	USD745C	SK1650C	B3
IMBR1550CT	SK1650C	B3	SB130	SK104	A3	SR106	SK106	A3	USD820	12SK40	A13
IMBR1560CT	SK1660C	B3	SB140	SK104	A3	SR302	SK302	A7	USD830	12SK40	A13
IMBR160	SK106	A3	SB150	SK106	A3	SR303	SK304	A7	USD835	12SK40	A13
IMBR1635	12SK40	A13	SB160	SK106	A3	SR304	SK304	A7	USD840	12SK40	A13
IMBR1645	12SK40	A13	SB170	SK108	A3	SR305	SK306	A7	USD845	12SK50	A13
IMBR1650	12SK50	A13	SB180	SK108	A3	SR306	SK306	A7	USD920	16SK40	A15
IMBR1660	12SK60	A13	SB190	SK110	A3	SR502	SK502	A9	USD935	16SK40	A15
IMBR2035CT	SK1640C	B3	SB1100	SK110	A3	SR503	SK504	A9	USD940	16SK40	A15
IMBR2045CT	SK1650C	B3	SB320	SK302	A7	SR504	SK504	A9	USD945	16SK50	A15
IMBR2050CT	SK1650C	B3	SB330	SK304	A7	SR505	SK506	A9	VSK1020	12SK40	A13
IMBR2060CT	SK1660C	B3	SB340	SK304	A7	SR506	SK506	A9	VSK1035	12SK40	A13
IMBR2090CT	SK16100C	B3	SB350	SK306	A7	SR802	12SK40	A13	VSK1045	12SK50	A13
IMBR20100CT	SK16100C	B3	SB360	SK306	A7	SR803	12SK40	A13	VSK12	SK1240C	B1
IMBR2535CT	SK2440C	B5	SB380	SK310	A7	SR804	12SK40	A13	VSK13	SK1240C	B1
IMBR2545CT	SK2450C	B5	SB3100	SK310	A7	SR805	12SK50	A13	VSK14	SK1240C	B1
IMBR2550CT	SK2450C	B5	SB520	SK502	A9	SR806	12SK60	A13	VSK120	SK102	A3
IMBR2560CT	SK2460C	B5	SB530	SK504	A9	SR1002	12SK40	A13	VSK130	SK104	A3
IMBR3035PT	SK3040C	B7	SB540	SK504	A9	SR1003	12SK40	A13	VSK140	SK104	A3
IMBR3045PT	SK3050C	B7	SB550	SK506	A9	SR1004	12SK40	A13	VSK2020	SK1640C	B3
IMBR3050PT	SK3050C	B7	SB560	SK506	A9	SR1005	12SK50	A13	VSK2035	SK1640C	B3
IMBR3060PT	SK3060C	B7	SB590	SK510	A9	SR1006	12SK60	A13	VSK2045	SK1650C	B3
IMBR320	SK302	A7	SB5100	SK510	A9	SR1602	SK1640C	B3	VSK2420	SK2440C	B5
IMBR330	SK304	A7	SBL1030CT	SK1240C	B1	SR1603	SK1640C	B3	VSK2435	SK2440C	B5
IMBR340	SK304	A7	SBL1040CT	SK1240C	B1	SR1604	SK1640C	B3	VSK2445	SK2450C	B5
IMBR350	SK306	A7	SBL1630CT	SK1640C	B3	SR1605	SK1650C	B3	VSK320	SK302	A7
IMBR360	SK306	A7	SBL1640CT	SK1640C	B3	SR1606	SK1660C	B3	VSK330	SK304	A7
IMBR4035PT	SK4040C	B7	SBL530	6SK40	A11	SR2020	SK2440C	B5	VSK340	SK304	A7
IMBR4045PT	SK4050C	B7	SBL530CT	SK1240C	B1	SR2030	SK2440C	B5	VSK520	SK502	A9
IMBR4050PT	SK4050C	B7	SBL540	6SK40	A11	SR2045	SK2450C	B5	VSK530	SK504	A9
IMBR4060PT	SK4060C	B7	SBL540CT	SK1240C	B1	SR3030	SK3040C	B7	VSK540	SK504	A9
IMBR735	12SK40	A13	SBLF1030	12SK40	A13	SR3040	SK3040C	B7	VSK62	6SK40	A11
IMBR745	12SK50	A13	SBLF1040	12SK40	A13	SR3045	SK3050C	B7	VSK63	6SK40	A11
IMBR750	12SK50	A13	SBLF1630C	SK1640C	B3	SR3050	SK3050C	B7	VSK64	6SK40	A11
IMBR760	12SK60	A13	SBLF1640C	SK1640C	B3	SR3060	SK3060C	B7	VSK920	16SK40	A15
IMBRF1035	12SK40	A13	SD241P	SK3050C	B7	SR4020	SK4040C	B9	VSK935	16SK40	A15
IMBRF1045	12SK50	A13	SD115	SK102	A3	SR4030	SK4040C	B9	VSK945	16SK50	A15
IMBRF1050	12SK50	A13	SD120	SK104	A3	SR4040	SK4040C	B9			
IMBRF1060	12SK60	A13	SD130	SK104	A3	SR4050	SK4040C	B9			
IMBR2050CT	SK1650C	B3	SD140	SK106	A3	SR5020	SK4040C	B9			
IMBR2060CT	SK1660C	B3	SD150	SK106	A3	SR5030	SK4040C	B9			
NST520	6SK40	A11	SD160	SK108	A3	SR5040	SK4040C	B9			
NST530	6SK40	A11	SD170	SK108	A3	SR5050	SK4050C	B9			

APPENDIX III - SUPER EFFICIENT and ULTRA FAST RECOVERY DIODE CROSS REFERENCE

INDUSTRY PART NO.	SUGGESTED DIOTEC REPLACEMENT PART NO.	PAGE NO.	INDUSTRY PART NO.	SUGGESTED DIOTEC REPLACEMENT PART NO.	PAGE NO.	INDUSTRY PART NO.	SUGGESTED DIOTEC REPLACEMENT PART NO.	PAGE NO.	INDUSTRY PART NO.	SUGGESTED DIOTEC REPLACEMENT PART NO.
BYT01-200	SPR12	C1	EGP10D	UFR102	C3	FEP16HT	SPR165C	D7	HER104	UFR103
BYT01-300	SPR13	C1	EGP10F	UFR103	C3	FEPF16AT	SPR1601C	D5	HER105	UFR104
BYT01-400	UFR104	C3	EGP10G	UFR104	C3	FEPF16BT	SPR1601C	D5	HER106	UFR106
BYT03-200	SPR32	C7	EGP10J	UFR106	C3	FEPF16CT	SPR1602C	D5	HER151	SPR21
BYT03-300	SPR33	C7	EGP10K	UFR108	C3	FEPF16DT	SPR1602C	D5	HER152	SPR21
BYT03-400	SPR34	C7	EGP10M	UFR110	C3	FEPF16FT	SPR1603C	D5	HER153	SPR22
BYT08P-200A	SPR82	C21	EGP20A	SPR21	C5	FEPF16GT	SPR1604C	D5	HER154	SPR23
BYT08P-300A	SPR83	C21	EGP20B	SPR21	C5	FEPF16HT	SPR1605C	D5	HER155	UFR24
BYT08P-400A	SPR84	C21	EGP20C	SPR22	C5	FEP30AP	UFR3001C	D9	HER156	UFR26
BYT08PI-200	8SPR02	C19	EGP20D	SPR22	C5	FEP30BP	UFR3001C	D9	HER301	UFR300
BYT08PI-300	8SPR03	C19	EGP20F	SPR23	C5	FEP30CP	UFR3002C	D9	HER302	UFR301
BYT08PI-400	8SPR04	C19	EGP20G	UFR24	C5	FEP30DP	UFR3002C	D9	HER303	UFR302
BYT12P-600A	SPR156	C25	EGP20J	UFR26	C5	FEP30FP	UFR3003C	D9	HER304	UFR303
BYT30P-200	CALL		EGP20K	UFR28	C5	FEP30GP	UFR3004C	D9	HER305	UFR304
BYT30P-300	CALL		EGP30A	SPR31	C7	FEP30HP	UFR3005C	D9	HER601	UFR600
BYT30P-400	CALL		EGP30B	SPR31	C7	FES16AT	SPR150	C25	HER602	UFR601
BYV27-100	SPR21	C5	EGP30C	SPR32	C7	FES16BT	SPR151	C25	HER603	UFR602
BYV27-150	SPR22	C5	EGP30D	SPR32	C7	FES16CT	SPR152	C25	HER604	UFR603
BYV27-200	SPR22	C5	EGP30F	SPR33	C7	FES16DT	SPR152	C25	HER605	UFR604
BYV27-50	SPR21	C5	EGP30G	SPR34	C7	FES16FT	SPR153	C25	HER801	SPR81
BYV28-100	SPR51	C13	EGP30J	UFR306	C9	FES16GT	SPR154	C25	HER802	SPR81
BYV28-150	SPR52	C13	EGP30K	UFR308	C9	FES16HT	SPR155	C25	HER803	SPR82
BYW100-100	SPR21	C5	EGP50A	SPR51	C13	FES16JT	SPR156	C25	HER804	SPR83
BYW100-150	SPR22	C5	EGP50B	SPR51	C13	FES8AT	SPR80	C21	HER805	SPR84
BYW100-200	SPR22	C5	EGP50C	SPR52	C13	FES8BT	SPR81	C21	HER806	SPR85
BYW100-50	SPR21	C5	EGP50D	SPR52	C13	FES8CT	SPR82	C21	HER1601	SPR161C
BYW29-100	SPR81	C21	EGP50F	SPR53	C13	FES8DT	SPR82	C21	HER1602	SPR161C
BYW29-100A	SPR81	C21	EGP50G	SPR54	C13	FES8FT	SPR83	C21	HER1603	SPR162C
BYW29-150	SPR82	C21	ER1001	UFR100	C3	FES8GT	SPR84	C21	HER1604	SPR163C
BYW29-150A	SPR82	C21	ER1002	UFR101	C3	FES8HT	SPR85	C21	HER1605	SPR164C
BYW29-200	SPR82	C21	ER1003	UFR102	C3	FES8JT	SPR86	C21	HER3001	UFR3001C
BYW29-200A	SPR82	C21	ER1004	UFR104	C3	FESF8AT	8SPR01	C19	HER3002	UFR3001C
BYW29-50	SPR81	C21	ER1005	UFR106	C3	FESF8BT	8SPR01	C19	HER3003	UFR3002C
BYW29-50A	SPR81	C21	ER1006	UFR108	C3	FESF8CT	8SPR02	C19	HER3004	UFR3003C
BYW51-50A	SPR161C	D7	FE1A	SPR11	C1	FESF8DT	8SPR02	C19	HER3005	UFR3004C
BYW51-100A	SPR161C	D7	FE1B	SPR11	C1	FESF8FT	8SPR03	C19	HER3006	UFR3005C
BYW51-150A	SPR162C	D7	FE1C	SPR12	C1	FESF8GT	8SPR04	C19	MUR105	SPR11
BYW51-200A	SPR162C	D7	FE1D	SPR12	C1	FESF8HT	8SPR05	C19	MUR110	SPR11
BYW77P-50	CALL		FE2A	SPR21	C5	GH1001	SPR11	C1	MUR115	SPR12
BYW77P-100	CALL		FE2B	SPR21	C5	GH1002	SPR11	C1	MUR120	SPR12
BYW77P-150	CALL		FE2C	SPR22	C5	GH1003	SPR12	C1	MUR130	SPR12
BYW77P-200	CALL		FE2D	SPR22	C5	GH1004	SPR12	C1	MUR140	UFR104
BYW80-50A	8SPR01	C19	FE3A	SPR31	C7	GH1101	SPR21	C5	MUR150	UFR106
BYW80-100A	8SPR01	C19	FE3B	SPR31	C7	GH1102	SPR21	C5	MUR160	UFR106
BYW80-150A	8SPR02	C19	FE3C	SPR32	C7	GH1103	SPR22	C5	MUR170	UFR108
BYW80-200A	8SPR02	C19	FE3D	SPR32	C7	GH1104	SPR22	C5	MUR180	UFR108
BYW81P-50A	SPR150	C25	FE5A	SPR51	C13	GH1301	SPR51	C13	MUR405	SPR51
BYW81P-100A	SPR151	C25	FE5B	SPR51	C13	GH1302	SPR51	C13	MUR410	SPR51
BYW81P-150A	SPR152	C25	FE5C	SPR52	C13	GH1303	SPR52	C13	MUR415	SPR52
BYW81P-200A	SPR152	C25	FE5D	SPR52	C13	GH1304	SPR52	C13	MUR420	SPR52
BYW98-50	SPR31	C7	FE6A	SPR51	C13	GH1401	SPR80	C21	MUR430	SPR53
BYW98-100	SPR31	C7	FE6B	SPR51	C13	GH1402	SPR81	C21	MUR440	SPR54
BYW98-150	SPR32	C7	FE6C	SPR52	C13	GH1403	SPR82	C21	MUR605CT	SPR601C
BYW98-200	SPR32	C7	FE6D	SPR52	C13	GH1404	SPR82	C21	MUR610CT	SPR601C
BYW99P-50	UFR3001C	D9	FEP16AT	SPR161C	D7	GI2401	SPR1601C	D5	MUR615CT	SPR602C
BYW99P-100	UFR3001C	D9	FEP16BT	SPR161C	D7	GI2402	SPR1601C	D5	MUR620CT	SPR602C
BYW99P-150	UFR3002C	D9	FEP16CT	SPR162C	D7	GI2403	SPR1602C	D5	MUR805	SPR81
BYW99P-200	UFR3002C	D9	FEP16DT	SPR162C	D7	GI2404	SPR1602C	D5	MUR810	SPR81
EGP10A	UFR101	C3	FEP16FT	SPR163C	D7	HER101	UFR100	C3	MUR815	SPR82
EGP10B	UFR102	C3	FEP16GT	SPR164C	D7	HER102	UFR101	C3	MUR820	SPR82
EGP10C	UFR102	C3	FEP16JT	SPR166C	D7	HER103	UFR102	C3	MUR830	SPR83

APPENDIX IV - STANDARD and FAST RECOVERY FULL WAVE BRIDGE RECTIFIER CROSS REFERENCE

INDUSTRY PART NO.	SUGGESTED DIOTEC REPLACEMENT PART NO.	PAGE NO.	INDUSTRY PART NO.	SUGGESTED DIOTEC REPLACEMENT PART NO.	PAGE NO.	INDUSTRY PART NO.	SUGGESTED DIOTEC REPLACEMENT PART NO.	PAGE NO.	INDUSTRY PART NO.	SUGGESTED DIOTEC REPLACEMENT PART NO.	PAGE NO.
2KBP005	SB200	E11	B250C3700/2200	SB506	E21	BR84DF	FSB204	G5	GBU6A	SBU6A	E23
2KBP005M	SB200	E11	B250C5000/3300	SB506	E21	BR86D	SB206	E11	GBU6D	SBU6D	E23
2KBP01	SB201	E11	B250C800M	WB156	E7	BR86DF	FSB206	G5	GBU6G	SBU6G	E23
2KBP01M	SB201	E11	B250C800DM	DI106	E11	BR88D	SB208	E11	GBU6J	SBU6J	E23
2KBP02	SB202	E11	B380C1000M	WB151	E7	BR88DF	FSB208	G5	GBU6K	SBU6K	E23
2KBP02M	SB202	E11	B380C1500M	WB151	E7	DB101	DI100	E1	GBU6M	SBU6M	E23
2KBP04	SB204	E11	B380C3700/2200	SB510	E21	DB102	DI101	E1	GBU8A	SBU8A	E23
2KBP04M	SB204	E11	B380C5000/3300	SB510	E21	DB103	DI102	E1	GBU8B	SBU8B	E29
2KBP06	SB206	E11	B380C800M	WB151	E7	DB104	DI104	E1	GBU8D	SBU8D	E29
2KBP06M	SB206	E11	B380C800DM	DI110	E11	DB105	DI106	E1	GBU8G	SBU8G	E29
2KBP08	SB208	E11	B40C1000M	WB151	E7	DF04	DI104	E1	GBU8J	SBU8J	E29
2KBP08M	SB208	E11	B40C1500DM	WB151	E7	DF06	DI106	E1	GBU8K	SBU8K	E29
2KBP10	SB210	E11	B40C3700/2200	SB501	E21	DF08	DI108	E1	GBU8M	SBU8M	E29
2KBP10M	SB210	E11	B40C5000/3000	SB501	E21	DF10	DI110	E1	KBL005	SB400L	E15
2W005	WB200	E9	B40C800M	WB151	E7	GBPC1005	DB300	E13	KBL01	SB401L	E15
2W01	WB201	E9	B40C800DM	WB151	E7	GBPC101	DB301	E13	KBL02	SB402L	E15
2W02	WB202	E9	B80C1000M	WB152	E7	GBPC102	DB302	E13	KBL04	SB404L	E15
2W04	WB204	E9	B80C1500M	WB152	E7	GBPC104	DB304	E13	KBL06	SB406L	E15
2W06	WB206	E9	B80C3700/2200	SB502	E21	GBPC106	DB306	E13	KBL08	SB408L	E15
2W08	WB208	E9	80C5000/3000	SB502	E21	GBPC108	DB308	E13	KBL10	SB410L	E15
2W10	WB210	E9	B80C800M	WB152	E7	GBPC110	DB310	E13	KBP005M	SB200	E11
3N246	SB200	E11	B80C800DM	DI102	E11	GBPC6005	DB600	E25	KBP01M	SB201	E11
3N247	SB201	E11	BR1505	DB1500P	E37	GBPC601	DB601	E25	KBP02M	SB202	E11
3N248	SB202	E11	BR151	DB1501P	E37	GBPC602	DB602	E25	KBP04M	SB204	E11
3N249	SB204	E11	BR1510	DB1510P	E37	GBPC604	DB604	E25	KBP06M	SB206	E11
3N250	SB206	E11	BR152	DB1502P	E37	GBPC606	DB606	E25	KBP08M	SB208	E11
3N251	SB208	E11	BR154	DB1504P	E37	GBPC608	DB608	E25	KBP10M	SB210	E11
3N252	SB210	E11	BR156	DB1506P	E37	GBPC610	DB610	E25	KBPC10-OC	DB1500P	E37
3N253	SB200	E11	BR158	DB1508P	E37	GBPC12005	DB1500P	E37	KBPC10-O1	DB1501P	E37
3N254	SB201	E11	BR2505	DB2500P	E41	GBPC1201	DB1501P	E37	KBPC10-O2	DB1502P	E37
3N255	SB202	E11	BR252	DB2502P	E41	GBPC1202	DB1502P	E37	KBPC10-O4	DB1504P	E37
3N256	SB204	E11	BR254	DB2504P	E41	GBPC1204	DB1504P	E37	KBPC10-O6	DB1506P	E37
3N257	SB206	E11	BR256	DB2506P	E41	GBPC1206	DB1506P	E37	KBPC10-O8	DB1508P	E37
3N258	SB208	E11	BR258	DB2508P	E41	GBPC1208	DB1508P	E37	KBPC10-10	DB1510P	E37
3N259	SB210	E11	BR3505	DB3500P	E45	GBPC1210	DB1510P	E37	KBPC25005	DB2500P	E41
APBPC303	ADB304	E13	BR351	DB3501P	E45	GBPC15005	DB1500P	E37	KBPC2501	DB2501P	E41
APBPC304	ADB304	E13	BR3510	DB3510P	E45	GBPC1501	DB1501P	E37	KBPC2502	DB2502P	E41
APBPC305	ADB306	E13	BR352	DB3502P	E45	GBPC1502	DB1502P	E37	KBPC2504	DB2504P	E41
APBPC306	ADB308	E13	BR354	DB3504P	E45	GBPC1504	DB1504P	E37	KBPC2506	DB2506P	E41
APBPC603	ADB604	E25	BR356	DB3506P	E45	GBPC1506	DB1506P	E37	KBPC2508	DB2508P	E41
APBPC604	ADB604	E25	BR358	DB3508P	E45	GBPC1508	DB1508P	E37	KBPC2510	DB2510P	E41
APBPC605	ADB606	E25	BR605	DB600	E25	GBPC1510	DB1510P	E37	KBPC35005	DB3500P	E45
APBPC606	ADB606	E25	BR61	DB601	E25	GBPC25005	DB2500P	E41	KBPC3501	DB3501P	E45
APBPC1502	ADB1504P	E37	BR610	DB610	E25	GBPC2501	DB2501P	E41	KBPC3502	DB3502P	E45
APBPC1504	ADB1504P	E37	BR62	DB602	E25	GBPC2502	DB2502P	E41	KBPC3504	DB3504P	E45
APBPC1506	ADB1506P	E37	BR64	DB604	E25	GBPC2504	DB2504P	E41	KBPC3506	DB3506P	E45
APBPC1508	ADB1508P	E37	BR66	DB606	E25	GBPC2506	DB2506P	E41	KBPC3508	DB3508P	E45
APBPC2502	ADB2504P	E41	BR68	DB608	E25	GBPC2508	DB2508P	E41	KBPC3510	DB3510P	E45
APBPC2504	ADB2504P	E41	BR805	SB200	E11	GBPC2510	DB2510P	E41	KBPC6005	DB600	E25
APBPC2506	ADB2506P	E41	BR805D	FSB200	G5	GBPC35005	DB3500P	E45	KBPC601	DB601	E25
APBPC2508	ADB2508P	E41	BR81D	SB201	E11	GBPC3501	DB3501P	E45	KBPC602	DB602	E25
APBPC3502	ADB3504P	E45	BR81DF	FSB210	G5	GBPC3502	DB3502P	E45	KBPC604	DB604	E25
APBPC3504	ADB3504P	E45	BR81OD	SB210	E11	GBPC3504	DB3504P	E45	KBPC606	DB606	E25
APBPC3506	ADB3506P	E45	BR81ODF	FSB201	G5	GBPC3506	DB3506P	E45	KBPC608	DB608	E25
APBPC3508	ADB3508P	E45	BR82D	SB202	E11	GBPC3508	DB3508P	E45	KBPC610	DB610	E25
B125C1000M	WB154	E7	BR82DF	FSB202	G5	GBPC3510	DB3510P	E45	KBPC8005	DB800	E31
B125C1500M	WB154	E7	BR84D	SB204	E11	GBU4A	SBU4A	E19	KBPC801	DB801	E31
B125C3700/200	SB504	E21	BR84DF	FSB204	G5	GBU4B	SBU4B	E19	KBPC802	DB802	E31
B125C5000/3000	SB504	E21	BR86D	SB206	E11	GBU4D	SBU4D	E19	KBPC804	DB804	E31
B125C800M	WB154	E7	BR86DF	FSB206	G5	GBU4G	SBU4G	E19	KBPC806	DB806	E31
B125C800DM	DI104	E1	BR88D	SB208	E11	GBU4J	SBU4J	E19	KBPC808	DB808	E31
B250C1000M	WB156	E7	BR88DF	FSB208	G5	GBU4K	SBU4K	E19	KBPC810	DB810	E31
B250C1500M	WB156	E7	BR84D	SB204	E11	GBU4M	SBU4M	E19	GBU4A	SBU4A	E19

APPENDIX IV - STANDARD and FAST RECOVERY FULL WAVE BRIDGE RECTIFIER CROSS REFERENCE

INDUSTRY PART NO.	SUGGESTED DIOTEC REPLACEMENT PART NO.	PAGE NO.	INDUSTRY PART NO.	SUGGESTED DIOTEC REPLACEMENT PART NO.	PAGE NO.	INDUSTRY PART NO.	SUGGESTED DIOTEC REPLACEMENT PART NO.	PAGE NO.	INDUSTRY PART NO.	SUGGESTED DIOTEC REPLACEMENT PART NO.	PAGE NO.
KBU4B	SBU4B	E19	MDA210	SB210	E11	PB66	DB606	E25	PBPC1004	DB1004	E33
KBU4D	SBU4D	E19	MDA2500	DB3500P	E45	PB66F	FDB606	G9	PBPC1005	DB1006	E33
KBU4G	SBU4G	E19	MDA2501	DB3501P	E45	PB68	DB608	E25	PBPC1006	DB1008	E33
KBU4J	SBU4J	E19	MDA2502	DB3502P	E45	PB68F	FDB608	G9	PBPC1007	DB1010	E33
KBU4K	SBU4K	E19	MDA2504	DB3504P	E45	PBDF101	DI100	E1	PBPC301	DB300	E13
KBU4M	SBU4M	E19	MDA2506	DB3506P	E45	PBDF102	DI101	E1	PBPC302	DB302	E13
KBU6A	SBU6A	E23	MDA3500	DB3500P	E45	PBDF103	DI102	E1	PBPC303	DB304	E13
KBU6B	SBU6B	E23	MDA3501	DB3501P	E45	PBDF104	DI104	E1	PBPC304	DB304	E13
KBU6D	SBU6D	E23	MDA3502	DB3502P	E45	PBDF105	DI106	E1	PBPC305	DB306	E13
KBU6G	SBU6G	E23	MDA3504	DB3504P	E45	PBDF106	DI108	E1	PBPC306	DB308	E13
KBU6J	SBU6J	E23	MDA3506	DB3506P	E45	PBDF107	DI110	E1	PBPC307	DB310	E13
KBU6K	SBU6K	E23	MDA3508	DB3508P	E45	PBL301	SB400L	E15	PBPC601	DB600	E25
KBU6M	SBU6M	E23	MDA3510	DB3510P	E45	PBL302	SB401L	E15	PBPC602	DB601	E25
KBU8A	SBU8A	E29	MDA970A1	SB400L	E15	PBL303	SB402L	E15	PBPC603	DB602	E25
KBU8B	SBU8B	E29	MDA970A2	SB401L	E15	PBL304	SB404L	E15	PBPC604	DB604	E25
KBU8D	SBU8D	E29	MDA970A3	SB402L	E15	PBL305	SB406L	E15	PBPC605	DB606	E25
KBU8G	SBU8G	E29	MDA970A5	SB404L	E15	PBL306	SB408L	E15	PBPC606	DB608	E25
KBU8J	SBU8J	E29	MDA970A6	SB406L	E15	PBL307	SB410L	E15	PBPC607	DB610	E25
KBU8K	SBU8K	E29	MP1005	DB1000	E33	PBL401	SB400L	E15	PBPC801	DB800	E31
KBU8M	SBU8M	E29	MP101	DB1001	E33	PBL402	SB401L	E15	PBPC802	DB801	E31
MB1005	DB1000	E33	MP1010	DB1010	E33	PBL403	SB402L	E15	PBPC803	DB802	E31
MB101	DB1001	E33	MP102	DB1002	E33	PBL404	SB404L	E15	PBPC804	DB804	E31
MB102	DB1002	E33	MP104	DB1004	E33	PBL405	SB406L	E15	PBPC805	DB806	E31
MB104	DB1004	E33	MP106	DB1006	E33	PBL406	SB408L	E15	PBPC806	DB808	E31
MB106	DB1006	E33	MP108	DB1008	E33	PBL407	SB410L	E15	PBPC807	DB810	E31
MB108	DB1008	E33	MP605	DB600	E25	PBM101	WB150	E7	PBU1001	SBU8A	E29
MB1505	DB1500P	E37	MP61	DB601	E25	PBM102	WB151	E7	PBU1002	SBU8B	E29
MB151	DB1501P	E37	MP610	DB610	E25	PBM103	WB152	E7	PBU1003	SBU8D	E29
MB152	DB1502P	E37	MP62	DB602	E25	PBM104	WB154	E7	PBU1004	SBU8G	E29
MB154	DB1504P	E37	MP64	DB604	E25	PBM105	WB156	E7	PBU1005	SBU8J	E29
MB156	DB1506P	E37	MP66	DB606	E25	PBM106	WB108	E7	PBU1006	SBU8K	E29
MB158	DB1508P	E37	MP68	DB608	E25	PBM107	WB1510	E7	PBU1007	SBU8M	E29
MB2505	DB2500P	E41	MP805	DB1000	E33	PBM151	WB150	E7	PBU401	SBU4A	E19
MB251	DB2501P	E41	MP81	DB1001	E33	PBM152	WB151	E7	PBU402	SBU4B	E19
MB252	DB2502P	E41	MP810	DB1010	E33	PBM153	WB152	E7	PBU403	SBU4D	E19
MB254	DB2504P	E41	MP82	DB1002	E33	PBM154	WB154	E7	PBU404	SBU4G	E19
MB256	DB2506P	E41	MP84	DB1004	E33	PBM155	WB156	E7	PBU405	SBU4J	E19
MB258	DB2508P	E41	MP86	DB1006	E33	PBM156	WB158	E7	PBU406	SBU4M	E19
MB3505	DB3500P	E45	MP88	DB1008	E33	PBM156	WB1510	E7	PBU407	SBU4M	E19
MB351	DB3501P	E45	PB305	DB300	E13	PBM201	WB200	E5	PBU601	SBU6A	E23
MB352	DB3502P	E45	PB305F	FDB300	G7	PBM202	WB201	E5	PBU602	SBU6B	E23
MB354	DB3504P	E45	PB31	DB301	E13	PBM203	WB202	E5	PBU603	SBU6D	E23
MB356	DB3506P	E45	PB31F	FDB301	G7	PBM204	WB204	E5	PBU604	SBU6G	E23
MB358	DB3508P	E45	PB310	DB310	E13	PBM205	WB206	E5	PBU605	SBU6J	E23
MB805	DB1000	E33	PB310F	FDB310	G7	PBM206	WB208	E5	PBU606	SBU6K	E23
MB81	DB1001	E33	PB32	DB302	E13	PBM207	WB210	E5	PBU607	SBU6M	E23
MB82	DB1002	E33	PB32F	FDB302	G7	PBP151	SB200	E11	PBU801	SBU8A	E29
MB84	DB1004	E33	PB34	DB304	E13	PBP152	SB201	E11	PBU802	SBU8B	E29
MB86	DB1006	E33	PB34F	FDB304	G7	PBP153	SB202	E11	PBU803	SBU8D	E29
MB88	DB1008	E33	PB36	DB306	E13	PBP154	SB204	E11	PBU804	SBU8G	E29
MDA100A	SB200	E11	PB36F	FDB306	G7	PBP155	SB206	E11	PBU805	SBU8J	E29
MDA101A	SB201	E11	PB38	DB308	E13	PBP156	SB208	E11	PBU806	SBU8K	E29
MDA102A	SB202	E11	PB38F	FDB308	G7	PBP157	SB210	E11	PBU807	SBU8M	E29
MDA104A	SB204	E11	PB605	DB600	E25	PBP201	SB200	E11	RDF005M	FDI100	G1
MDA106A	SB206	E11	PB605F	FDB600	G9	PBP202	SB201	E11	RDF01M	FDI101	G1
MDA108A	SB208	E11	PB61	DB601	E25	PBP203	SB202	E11	RDF02M	FDI102	G1
MDA110A	SB210	E11	PB61F	FDB601	G9	PBP204	SB204	E11	RDF04M	FDI104	G1
MDA200	SB200	E11	PB610	DB610	E25	PBP205	SB206	E11	RDF06M	FDI106	G1
MDA201	SB201	E11	PB610F	FDB610	G9	PBP206	SB208	E11	RDF08M	FDI108	G1
MDA202	SB202	E11	PB62	DB602	E25	PBP207	SB210	E11	RKBPC15005	FDB2500P	E41
MDA204	SB202	E11	PB62F	FDB602	G9	PBPC1001	DB1000	E33	RKBPC1501	FDB2501P	E41
MDA206	SB206	E11	PB64	DB604	E25	PBPC1002	DB1001	E33	RKBPC1502	FDB2502P	E41
MDA208	SB208	E11	PB64F	FDB604	G9	PBPC1003	DB1002	E33	RKBPC1504	FDB2504P	E41

APPENDIX IV - STANDARD and FAST RECOVERY FULL WAVE BRIDGE RECTIFIER CROSS REFERENCE

INDUSTRY PART NO.	SUGGESTED DIOTEC REPLACEMENT PART NO.	PAGE NO.	INDUSTRY PART NO.	SUGGESTED DIOTEC REPLACEMENT PART NO.	PAGE NO.	INDUSTRY PART NO.	SUGGESTED DIOTEC REPLACEMENT PART NO.	PAGE NO.	INDUSTRY PART NO.	SUGGESTED DIOTEC REPLACEMENT PART NO.	PAGE NO.
RKBPC1506	FDB2506P	G15	RS406L	SB408L	E15	VJ148X	Call DIOTEC		W005M	WB150	E7
RKBPC1508	FDB2508P	G15	RS407L	SB410L	E15	VJ247	ADB1004	E33	W01M	WB151	E7
RKBPC1510	FDB2510P	G15	RS601	SBU6A	E23	VJ248	DB1002	E33	W02M	WB152	E7
RKBPC2500S	FDB2500P	G15	RS602	SBU6B	E23	VJ248X	Call DIOTEC		W04M	WB154	E7
RKBPC2501	FDB2501P	G15	RS603	SBU6D	E23	VJ447	ADB1004	E33	W06M	WB156	E7
RKBPC2502	FDB2502P	G15	RS604	SBU6G	E23	VJ448	DB1004	E33	W08M	WB158	E7
RKBPC2504	FDB2504P	G15	RS605	SBU6J	E23	VJ647	ADB1006	E33	W10M	WB1510	E7
RKBPC2506	FDB2506P	G15	RS606	SBU6K	E23	VJ648	DB1006	E33	W10M	WB1510	E7
RKBPC2508	FDB2508P	G15	RS607	SBU6M	E23	VJ847	ADB1008	E33			
RKBPC2510	FDB2510P	G15	SCB1500S	DB1500P	E37	VJ848	DB1008	E33			
RKBPC3500S	FDB3500	G13	SCB1501	DB1501P	E37	VK048	DB3500P	E45			
RKBPC3501	FDB3501	G13	SCB1502	DB1502P	E37	VK048X	FDB3500P	G17			
RKBPC3502	FDB3502	G13	SCB1504	DB1504P	E37	VK1048	DB3510P	E45			
RKBPC3504	FDB3504	G13	SCB1506	DB1506P	E37	VK148	DB3501P	E45			
RKBPC3506	FDB3506	G13	SCB1508	DB1508P	E37	VK148X	FDB3501P	G17			
RKBPC3508	FDB3508	G13	SCB1510	DB1510P	E37	VK247	ADB3504P	E45			
RPBDF101	FDI100	G1	SCB2500S	DB2500P	E41	VK248	DB3502P	E45			
RPBDF102	FDI101	G1	SCB2501	DB2501P	E41	VK248X	FDB3502P	G17			
RPBDF103	FDI102	G1	SCB2502	DB2502P	E41	VK447	ADB3504P	E45			
RPBDF104	FDI104	G1	SCB2504	DB2504P	E41	VK448	DB3504P	E45			
RPBDF105	FDI106	G1	SCB2506	DB2506P	E41	VK448X	FDB3504P	G17			
RPBDF106	FDI108	G1	SCB2508	DB2508P	E41	VK647	ADB3506P	E45			
RPBDF107	FDI104	G1	SCB2510	DB2510P	E41	VK648	DB3506P	E45			
RPBPC301	FDB300	G7	SCB3500S	DB3500P	E45	VK648X	FDB3506P	G17			
RPBPC302	FDB301	G7	SCB3501	DB3501P	E45	VK848	DB3508P	E45			
RPBPC303	FDB302	G7	SCB3502	DB3502P	E45	VL048	DB1500P	E37			
RPBPC304	FDB304	G7	SCB3504	DB3504P	E45	VL1048	DB1510P	E37			
RPBPC305	FDB306	G7	SCB3506	DB3506P	E45	VL148	DB1501P	E37			
RPBPC306	FDB308	G7	SCB3508	DB3508P	E45	VL247	ADB1504P	E37			
RPBPC307	FDB310	G7	SCB3510	DB351010P	E45	VL248	DB1502P	E37			
RPBPC601	FDB600	G9	VE08	WB150	E7	VL447	ADB1504P	E37			
RPBPC602	FDB601	G9	VE08X	FWB150	G3	VL448	DB1504P	E37			
RPBPC603	FDB602	G9	VE108	WB1510	E7	VL647	ADB1506P	E37			
RPBPC604	FDB604	G9	VE18	WB151	E7	VL648	DB1506P	E37			
RPBPC605	FDB606	G9	VE18X	FWB151	G3	VL848	DB1508P	E37			
RPBPC606	FDB608	G9	VE28	WB152	E7	VM08	DI100	E1			
RPBPC607	FDB610	G9	VE28X	FWB152	G3	VM08X	FDI100	G1			
RS101	SB200	E11	VE48	WB154	E7	VM108	DI110	E1			
RS102	SB201	E11	VE48X	FWB154	G3	VM18	DI101	E1			
RS103	SB202	E11	VE68	WB156	E7	VM18X	FDI101	G1			
RS104	SB204	E11	VE68X	FWB156	G3	VM28	DI102	E1			
RS105	SB206	E11	VE88	WB158	E7	VM28X	FDI102	G1			
RS106	SB208	E11	VH048	DB600	E25	VM48	DI104	E1			
RS107	SB210	E11	VH048X	FDB600	G9	VM48X	FDI104	G1			
RS201	SB200	E11	VH1048	DB610	E25	VM68	DI106	E1			
RS202	SB201	E11	VH1048X	FDB610	G9	VM68X	FDI106	G1			
RS203	SB202	E11	VH148	DB601	E25	VM88	DI108	E1			
RS204	SB204	E11	VH148X	FDB601	G9	VS048	DB300	E13			
RS205	SB206	E11	VH247	ADB604	E25	VS048X	FDB300	G7			
RS206	SB208	E11	VH248	DB602	E25	VS1048	DB310	E13			
RS207	SB210	E11	VH248X	FDB602	G9	VS148	DB301	E13			
RS401S	SB400L	E15	VH447	ADB604	E25	VS148X	FDB301	G7			
RS402S	SB401L	E15	VH448	DB604	E25	VS247	ADB304	E13			
RS403S	SB402L	E15	VH448X	FDB604	G9	VS248	DB302	E13			
RS404S	SB404L	E15	VH647	ADB606	E25	VS248X	FDB302	G7			
RS405S	SB406L	E15	VH648	DB606	E25	VS447	ADB304	E13			
RS406S	SB408L	E15	VH648X	FDB606	G9	VS448	DB304	E13			
RS407S	SB410L	E15	VH847	ADB608	E25	VS448X	FDB304	G7			
RS401L	SB400L	E15	VH848	DB608	E25	VS647	ADB306	E13			
RS402L	SB401L	E15	VJ048	DB1000	E33	VS648	DB306	E13			
RS403L	SB402L	E15	VJ048X	Call DIOTEC		VS648X	FDB306	G7			
RS404L	SB404L	E15	VJ1048	DB1010	E33	VS847	ADB308	E13			
RS405L	SB406L	E15	VJ148	DB1001	E33	VS848	DB308	E13			

APPENDIX V - GENERAL PURPOSE and FAST RECOVERY SILICON DIODE CROSS REFERENCE

INDUSTRY PART NO.	SUGGESTED DIOTEC REPLACEMENT PART NO.	PAGE NO.	INDUSTRY PART NO.	SUGGESTED DIOTEC REPLACEMENT PART NO.	PAGE NO.	INDUSTRY PART NO.	SUGGESTED DIOTEC REPLACEMENT PART NO.	PAGE NO.	INDUSTRY PART NO.	SUGGESTED DIOTEC REPLACEMENT PART NO.	PAGE NO.
1N4001	1N4001	H1	1N5615(GP)	RGP102	H25	BYW73	RGP304	H31	FR204	RGP204	H27
1N4001GP	1N4001G	H3	1N5616(GP)	RGP104	H25	BYW74	RGP304	H31	FR204G	RGP204	H27
1N4002	1N4002	H1	1N5617(GP)	RGP104	H25	BYW75	RGP306	H31	FR205	RGP206	H27
1N4002GP	1N4002G	H3	1N5618(GP)	RGP106	H25	BYW76	RGP306	H31	FR205G	RGP206	H27
1N4003	1N4003	H1	1N5619(GP)	RGP106	H25	DI750	GP600	H17	FR206	RGP208	H27
1N4003GP	1N4003G	H3	1N5620(GP)	RGP108	H25	DI751	GP601	H17	FR207	RGP210	H27
1N4004	1N4004	H1	1N5621(GP)	RGP108	H25	DI752	GP602	H17	FR301	RP300	H29
1N4004GP	1N4004G	H3	1N5622(GP)	RGP110	H25	DI754	GP604	H17	FR301G	RGP300	H31
1N4005	1N4005	H1	1N5623(GP)	RGP110	H25	DI7810	RP100	H23	FR302	RP301	H29
1N4005GP	1N4005G	H3	1N5624(GP)	RGP302	H31	DI7811	RP101	H23	FR302G	RP301	H31
1N4006	1N4006	H1	1N5625(GP)	RGP304	H31	DI7812	RP102	H23	FR303	RP302	H29
1N4006GP	1N4006G	H3	1N5626(GP)	RGP306	H31	DI7814	RP104	H23	FR303G	RGP302	H31
1N4007	1N4007	H1	1N5627(GP)	RGP308	H31	DI7816	RP106	H23	FR304	RP304	H29
1N4007GP	1N4007G	H3	6A05	GP600	H17	DI7817	RP108	H23	FR304G	RGP304	H31
1N4933	1N4933	H21	6A05G	GP600	H17	DI7818	RP110	H23	FR305	RP306	H29
1N4933GP	RGP100	H25	6A1	GP601	H17	DI7910	RGP300	H31	FR305G	RGP306	H31
1N4934	1N4934	H21	6A1G	GP601	H17	DI7911	RGP301	H31	FR306	RP308	H29
1N4934GP	RGP101	H25	6A2	GP602	H17	DI7912	RGP302	H31	FR307	RGP308	H31
1N4935	1N4935	H21	6A2G	GP602	H17	DI7914	RGP304	H31	FR501	RP600	H33
1N4935GP	RGP102	H25	6A4	GP604	H17	DI7916	RGP306	H31	FR502	RP601	H33
1N4936	1N4936	H21	6A4G	GP604	H17	DI7917	RGP308	H31	FR503	RP602	H33
1N4936GP	RGP104	H25	6A6	GP606	H17	DI7918	RGP310	H31	FR504	RP604	H33
1N4937	1N4937	H21	6A6G	GP606	H17	DIR500	GP400	H15	FR505	RP606	H33
1N4937GP	RGP106	H25	6A8	GP608	H17	DIR501	GP401	H15	FR506	RP608	H33
1N4942	RGP102	H25	6A10	GP610	H17	DIR502	GP402	H15	FR507	RP601	H33
1N4942GP	RGP102	H25	BY214-50	GP600	H17	DIR504	GP404	H15	FR601	RP600	H33
1N4944	RGP104	H25	BY214-100	GP601	H17	DIR506	GP406	H15	FR601G	RP600	H33
1N4944GP	RGP104	H25	BY214-200	GP602	H17	DIR508	GP408	H15	FR602	RP601	H33
1N4946	RGP106	H25	BY214-400	GP604	H17	DIR510	GP410	H15	FR602G	RP601	H33
1N4946GP	RGP106	H25	BY214-600	GP606	H17	ESM765-100A	RGP801	H35	FR603	RP602	H33
1N4947	RGP108	H25	BY218-100	RGP301	H31	ESM765-200A	RGP802	H35	FR603G	RP602	H33
1N4947GP	RGP108	H25	BY218-200	RGP302	H31	ESM765-400A	RGP804	H35	FR604	RP604	H33
1N4948	RGP110	H25	BY218-400	RGP304	H31	ESM765-600A	RGP806	H35	FR604G	RP604	H33
1N4948GP	RGP110	H25	BY218-600	RGP306	H31	FR101	RP100	H23	FR605	RP606	H33
1N5059(GP)	RGP102	H25	BY233-200A	RGP802	H35	FR101G	RGP100	H25	FR605G	RP606	H33
1N5060(GP)	RGP104	H25	BY233-400A	RGP804	H35	FR102	RP101	H23	FR606	RP608	H33
1N5061(GP)	RGP106	H25	BY233-600A	RGP806	H35	FR102G	RGP101	H25	FR607	RP102	H33
1N5062(GP)	RGP108	H25	BY251	GP402	H15	FR103	RP102	H23	FR801	RGP800	H35
1N5391	1N5391	H7	BY252	GP404	H15	FR103G	RGP102	H25	FR802	RGP801	H35
1N5391GP	1N5391	H7	BY253	GP406	H15	FR104	RP104	H23	FR803	RGP802	H35
1N5392	1N5392	H7	BY254	GP408	H15	FR104G	RGP104	H25	FR804	RGP804	H35
1N5392GP	1N5392	H7	BY254S	GP410	H15	FR105	RP106	H23	FR805	RGP806	H35
1N5393	1N5393	H7	BY255	GP410	H15	FR105G	RGP106	H25	GI750	GP600	H17
1N5393GP	1N5393	H7	BY296	RGP301	H31	FR106	RP108	H23	GI751	GP601	H17
1N5394	1N5395	H7	BY297	RGP302	H31	FR107	RP110	H25	GI752	GP602	H17
1N5394GP	1N5395	H7	BY296	RGP304	H31	FR151	RGP200	H27	GI754	GP604	H17
1N5395	1N5395	H7	BY298	RGP306	H31	FR151G	RGP200	H27	GI756	GP606	H17
1N5395GP	1N5395	H7	BY299	RGP308	H31	FR152	RGP201	H27	GI758	GP608	H17
1N5396	1N5397	H7	BY396	RGP301	H31	FR152G	RGP201	H27	GI810	RGP200	H27
1N5396GP	1N5397	H7	BY397	RGP302	H31	FR153	RGP202	H27	GI811	RGP201	H27
1N5397	1N5397	H7	BY398	RGP304	H31	FR153G	RGP202	H27	GI812	RGP202	H27
1N5397GP	1N5397	H7	BY399	RGP308	H31	FR154	RGP204	H27	GI814	RGP204	H27
1N5398	1N5398	H7	BYT13-600	RGP306	H31	FR154G	RGP204	H27	GI816	RGP206	H27
1N5398GP	1N5398	H7	BYT13-800	RGP308	H31	FR155	RGP206	H27	GI817	RGP208	H27
1N5399	1N5399	H7	BYT71-100A	RGP801	H35	FR155G	RGP206	H27	GI818	RGP210	H27
1N5399GP	1N5399	H7	BYT71-400A	RGP804	H35	FR156	RGP206	H27	GI820	RP600	H33
1N5400	1N5400	H11	BYT71-600A	RGP806	H35	FR157	RGP208	H27	GI821	RP601	H33
1N5401	1N5401	H11	BYW32	RGP202	H27	FR201	RGP200	H27	GI822	RP602	H33
1N5402	1N5402	H11	BYW33	RGP204	H27	FR201G	RGP200	H27	GI824	RP604	H33
1N5403	1N5404	H11	BYW34	RGP204	H27	FR202	RGP201	H27	GI826	RP606	H33
1N5404	1N5404	H11	BYW35	RGP206	H27	FR202G	RGP201	H27	GP10A	GP100	H5
1N5405	1N5406	H11	BYW36	RGP206	H27	FR203	RGP202	H27	GP10B	GP101	H5
1N5406	1N5406	H11	BYW72	RGP302	H31	FR203G	RGP202	H27	GP10D	GP102	H5

APPENDIX V - GENERAL PURPOSE and FAST RECOVERY SILICON DIODE CROSS REFERENCE (Cont'd)

INDUSTRY PART NO.	SUGGESTED DIOTEC REPLACEMENT PART NO.	PAGE NO.	INDUSTRY PART NO.	SUGGESTED DIOTEC REPLACEMENT PART NO.	PAGE NO.	INDUSTRY PART NO.	SUGGESTED DIOTEC REPLACEMENT PART NO.	PAGE NO.	INDUSTRY PART NO.	SUGGESTED DIOTEC REPLACEMENT PART NO.	PAGE NO.
GP10G	GP104	H5	P600G	GP604	H17	PX6A04	GP604	H17	RGP25K	RGP308	H31
GP10J	GP106	H5	P600J	GP606	H17	PX6A05	GP606	H17	RGP25M	RGP310	H31
GP10K	GP108	H5	P600K	GP608	H17	PX6A06	GP608	H17	RGP30A	RGP300	H31
GP10M	GP110	H5	P600M	GP610	H17	PX6A07	GP610	H17	RGP30B	RGP301	H31
GP15A	GP200	H9	PF4HZ	GP404	H15	PY124	RGP202	H27	RGP30D	RGP302	H31
GP15B	GP201	H9	PF6HZ	GP406	H15	PY125	GP204	H9	RGP30G	RGP304	H31
GP15D	GP202	H9	PF8HZ	GP408	H15	PY126	GP206	H9	RGP30J	RGP306	H31
GP15G	GP204	H9	PFR850	RP300	H29	PY55-350	RGP204	H27	RGP30K	RGP308	H31
GP15J	GP206	H9	PFR851	RP301	H29	PY55-600	RGP206	H27	RGP30M	RGP310	H31
GP15K	GP208	H9	PFR852	RP302	H29	RG4A	RGP300	H31	RL201	GP200	H9
GP15M	GP210	H9	PFR854	RP304	H29	RG4B	RGP301	H31	RL201G	GP200	H9
GP20A	GP200	H9	PFR856	RP306	H29	RG4D	RGP302	H31	RL202	GP201	H9
GP20B	GP201	H9	PL4HZ	1N4004G	H33	RG4G	RGP304	H31	RL202G	GP201	H9
GP20D	GP202	H9	PL6HZ	1N4006G	H33	RG4J	RGP306	H31	RL203	GP202	H9
GP20G	GP204	H9	PL8HZ	1N4008G	H33	RG4K	RGP308	H31	RL203G	GP202	H9
GP20J	GP206	H9	PLR810	RGP200	H27	RG4M	RGP310	H31	RL204	GP204	H9
GP20K	GP208	H9	PLR811	RGP201	H27	RGP10A	RGP100	H25	RL204G	GP204	H9
GP20M	GP210	H9	PLR812	RGP202	H27	RGP10B	RGP101	H25	RL205	GP206	H9
GP30A	GP400	H15	PLR813	RGP204	H27	RGP10D	RGP102	H25	RL205G	GP206	H9
GP30B	GP401	H15	PLR814	RGP204	H27	RGP10G	RGP104	H25	RL206	GP208	H9
GP30D	GP402	H15	PLR816	RGP206	H27	RGP10J	RGP106	H25	RL207	GP210	H9
GP30G	GP404	H15	PLR817	RGP208	H27	RGP10K	RGP108	H25	RS8AT	RGP800	H35
GP30J	GP406	H15	PLR818	RGP210	H27	RGP10M	RGP110	H25	RS8BT	RGP801	H35
GP30K	GP408	H15	PR1001	RP100	H23	RGP15A	RGP200	H27	RS8DT	RGP802	H35
GP30M	GP410	H15	PR1002	RP101	H23	RGP15B	RGP201	H27	RS8GT	RGP804	H35
JO5	GP200	H9	PR1003	RP102	H23	RGP15D	RGP202	H27	RS8JT	RGP806	H35
JO5G	RGP200	H27	PR1004	RP104	H23	RG1A	RGP100	H25	V322	GP402	H15
J1	GP201	H9	PR1005	RP106	H23	RG1B	RGP101	H25	V324	GP404	H15
J1G	RGP201	H27	PR1006	RP108	H23	RG1D	RGP102	H25	V326	GP406	H15
J2	GP202	H9	PR1007	RP110	H23	RG1G	RGP104	H25	V328	GP408	H15
J2G	RGP202	H27	PR121	GP1120	I1	RG1J	RGP106	H25	V330	GP400	H15
J4	GP204	H9	PR141	RGP1150	H27	RG1K	RGP108	H25	V330X	RGP300	H31
J4G	RGP204	H27	PR1501	RGP200	H27	RG1M	RGP110	H25	V331	GP401	H15
J6	GP206	H9	PR1502	RGP201	H27	RG2A	RGP200	H27	V331X	RGP301	H31
J6G	RGP206	H27	PR1503	RGP202	H27	RG2B	RGP201	H27	V332	GP402	H15
J8	GP208	H9	PR1504	RGP204	H27	RG2D	RGP202	H27	V332X	RGP302	H31
J10	GP210	H9	PR1505	RGP206	H27	RG2G	RGP204	H27	V334	GP404	H15
MR500	GP400	H15	PR1506	RGP206	H27	RG2J	RGP206	H27	V334X	RGP304	H31
MR501	GP401	H15	PR1507	RGP208	H27	RG2K	RGP208	H27	V336	GP406	H15
MR502	GP402	H15	PR3001	RP300	H29	RG2M	RGP210	H27	V336X	RGP306	H31
MR504	GP404	H15	PR3002	RP301	H29	RG3A	RGP300	H31	V342	GP404	H15
MR506	GP406	H15	PR3003	RP302	H29	RG3B	RGP301	H31	V344	GP404	H15
MR508	GP408	H15	PR3004	RP304	H29	RG3D	RGP302	H31	V346	GP406	H15
MR510	GP410	H15	PR3005	RP306	H29	RG3G	RGP304	H31	V348	GP408	H15
MR750	GP400	H15	PR3006	RP308	H29	RG3J	RGP306	H31	V350	GP400	H15
MR751	GP600	H17	PR3007	RP308	H29	RG3K	RGP308	H31	V350X	RGP300	H31
MR752	GP601	H17	PR6001	RP600	H33	RG3M	RGP310	H31	V351	GP401	H15
MR754	GP602	H17	PR6002	RP601	H33	RGP15G	RGP204	H27	V351X	RGP301	H31
MR756	GP604	H17	PR6003	RP602	H33	RGP15J	RGP206	H27	V3510	GP410	H15
MR758	GP608	H17	PR6004	RP604	H33	RGP15K	RGP208	H27	V352	GP402	H15
MR760	GP610	H17	PR6005	RP606	H33	RGP15M	RGP210	H27	V352X	RGP302	H31
P300A	GP400	H15	PR6006	RP608	H33	RGP20A	RGP200	H27	V354	GP404	H15
P300B	GP401	H15	PR6007	RP610	H33	RGP20B	RGP201	H27	V354X	RGP304	H31
P300D	GP402	H15	PX4A01	GP400	H15	RGP20D	RGP202	H27	V356	GP406	H15
P300G	GP404	H15	PX4A02	GP401	H15	RGP20G	RGP204	H27	V356X	RGP306	H31
P300J	GP406	H15	PX4A03	GP402	H15	RGP20J	RGP206	H27	V358	GP408	H15
P300K	GP408	H15	PX4A04	GP404	H15	RGP20K	RGP208	H27			
P300M	GP410	H15	PX4A05	GP406	H15	RGP20M	RGP210	H27			
P511	RGP1150	I3	PX4A06	GP408	H15	RGP25A	RGP300	H31			
P513	RGP1180	I3	PX4A07	GP410	H15	RGP25B	RGP301	H31			
P600A	GP600	H17	PX6A01	RP600	H17	RGP25D	RGP302	H31			
P600B	GP601	H17	PX6A02	GP601	H17	RGP25G	RGP304	H31			
P600D	GP602	H17	PX6A03	GP602	H17	RGP25J	RGP306	H31			

APPENDIX VI - ACRONYMS, ABBREVIATIONS, and SYMBOLS

$^{\circ}\text{C}$	Degrees Centigrade
$^{\circ}\text{C/W}$	Degrees Centigrade per Watt
Ω	Ohms
μA	Microamperes
μS or μSec	Microseconds
A	Amperes
AC	Alternating Current
C_j	Junction Capacitance
cm	Centimeter
DIA	Diameter
DC	Direct Current
DUT	Diode Under Test
EIA	Electronic Industries Alliance
Hz	Hertz
I_F	Forward Current
I_{FSM}	Peak Forward Surge Current
In-lb	Inch - Pounds
I_o	Average Forward Rectified Current
I_R	DC Reverse Current
I_{RM}	Maximum DC Reverse Current at Rated Blocking Voltage
I_{RR}	Repetitive Reverse Current
I_{RSM}	Maximum Non-Repetitive Surge Current
I^2t	Thermal Energy (Rating For Fusing)
JEDEC	Joint Electron Device Engineering Council (of The EIA)
Kgs	Kilograms
MHz	MegaHertz
mm	Millimeters
mS	Millisecond
nS	Nanosecond
pF	Picofarad
P_R	Continuous Power Dissipation in The $V_{(BR)}$ Region
P_{RM}	Maximum Power Dissipation in The $V_{(BR)}$ Region
RMS	Root Mean Square
$R_{\theta CF}$	Thermal Resistance - Case to Fin
$R_{\theta JA}$	Thermal Resistance - Junction to Ambient
$R_{\theta JC}$	Thermal Resistance - Junction to Case
$R_{\theta JL}$	Thermal Resistance - Junction to Lead
T_A	Ambient Temperature
T_C	Case Temperature
T_J	Junction Temperature
T_L	Lead Temperature
T_{RR}	Reverse Recovery Time
T_{STG}	Storage Temperature
U/L or UL	Underwriters Laboratories
$V_{(BR)}$	Breakdown (Avalanche) Voltage
$V_{(BR)Max}$	Breakdown (Avalanche) Voltage
$V_{(BR)Min}$	Breakdown (Avalanche) Voltage
V_{DC}	D. C. Voltage
V_{FM}	Maximum Forward Voltage Drop
V_{ISO}	Minimum Insulation Breakdown Voltage
V_R	Reverse Voltage
V_{RM}	Maximum Reverse (Blocking) Voltage
V_{RSM}	Maximum Non-Recurrent Reverse Voltage
V_{RRM}	Maximum Recurrent Reverse Voltage
$V_{R(RMS)}$	RMS Reverse Voltage
V_{RSM}	RMS Reverse Voltage
V_{RWM}	Working Peak Reverse Voltage

APPENDIX VII - ALPHA-NUMERIC PRODUCT INDEX

PART NUMBER	PAGE	PART NUMBER	PAGE	PART NUMBER	PAGE
Numbered		D. (Cont'd)		S. (Cont'd)	
1N4001-1N4007	H1	DB600-DB610	E25	SB500-SB510	E21
1N4001G-1N4007G	H3	DB800-DB810	E31	SBU4A-SBU4M	E19
1N4148	H19	DB1000-DB1010	E33	SBU6A-SBU6M	E23
1N4933-1N4937	H21	DB1500-DB1510	E35	SBU8A-SBU8M	E29
1N5391-1N5399	H7	DB1500P-DB1510P	E37	SDB4000-SDB4010	E47
1N5400-1N5408	H11	DB2500-DB2510	E39	SDB5000-SDB5010	E49
1N5400G-1N5408G	H13	DB2500P-DB2510P	E41	SK102-SK110	A3
1N5817-1N5819	A1	DB3500-DB3510	E43	SK302-SK310	A7
1N5820-1N5822	A5	DB3500P-DB3510P	E45	SK502-SK510	A9
6SK40-6SK100	A11	DB5000P-DB5010P	E51	SK1240C-SK12100C	B1
6SPR01-6SPR05	C17	DI100-DI110	E1	SK1640C-SK16100C	B3
8SPR01-8SPR05	C19	F.		SK2440C-SK24100C	B5
12SPR01-12SPR05	C23	FDB300-FDB310	G7	SK3040C-SK30100C	B7
12SK40-12SK100	A13	FDB600-FDB610	G9	SK4040C-SK40100C	B9
16SK40-16SK100	A15	FDB2500-FDB2510	G11	SK6030C-SK6070C	B11
30SK30-30SK70	A17	FDB2500P-FDB2510P	G15	SPR11-SPR14	C1
A.		FDB3500-FDB3510	G13	SPR21-SPR23	C5
ADB304-ADB308	E13	FDB3500P-FDB3510P	G17	SPR30-SPR34	C7
ADB604-ADB608	E25	FDI100-FDI110	G1	SPR51-SPR54	C13
ADB804-ADB808	E31	FSB200-FSB210	G5	SPR81-SPR86	C21
ADB1004-ADB1008	E33	FWB150-FWB1510	G3	SPR150-SPR156	C25
ADB1504-ADB1508	E35	G.		SPR161C-SPR166C	D7
ADB1504P-ADB1508P	E37	GP100-GP110	H5	SPR601C-SPR605C	D1
ADB2504-ADB2508	E39	GP200-GP210	H9	SPR1001C-SPR1005C	D3
ADB2504P-ADB2508P	E41	GP400-GP410	H15	SPR1601C-SPR1605C	D5
ADB3504-ADB3508	E43	GP600-GP610	H17	T.	
ADB3504P-ADB3508P	E45	GP1120-GP1500	I1	TVS3527	J1
ADB5004P-ADB5008P	E51	H.		TVS3527D	J5
AHBU604-AHBU608	E27	HBU600-HBU610	E27	TVS3527S	J3
ASB404L-ASB408L	E15	K.		TVS5027	J11
B.		KBL00-KBL10	E17	TVS5027S	J13
BAR1200D-BAR1210D	K1	P.		TVS3527PFA	J7
BAR2500D-BAR2510D	K3	P6KE6.8-P6KE400CA	J19	TVS3527PFC	J9
BAR3500-BAR3510	K5	R.		TVS5027PFA	J15
BAR3500D-BAR3510D	K9	RGP100-RGP110	H25	TVS5027PFC	J17
BAR3500S-BAR3510S	K7	RGP200-RGP210	H27	U.	
BAR5000-BAR5010	K11	RGP300-RGP310	H31	UFR24-UFR28	C5
BAR5000D-BAR5010D	K15	RGP800-RGP806	H35	UFR100-UFR110	C3
BAR5000S-BAR5010S	K13	RGP1120-RGP1500	I3	UFR300-UFR310	C7
BAR6000-BAR6010	K17	RP100-RP110	H23	UFR400-UFR410	C11
BAR6000D-BAR6010D	K21	RP300-RP310	H29	UFR600-UFR608	C15
BAR6000S-BAR6010S	K19	RP600-RP610	H33	UFR3001C-UFR3005C	D9
BAR7500-BAR7510	K23	S.		W.	
BAR7500D-BAR7510D	K27	S1A-S1M	H7	WB100-WB110	E5
BAR7500S-BAR7510S	K25	S1NB05-S1NB100	E3	WB150-WB1510	E7
D.		SB200-SB210	E11	WB200-WB210	E9
DB300-DB310	E13	SB400L-SB410L	E15		

APPENDIX VIII - SAMPLE REQUEST FORM

THE SAMPLE REQUEST FORM IS ON THE REVERSE SIDE OF THIS PAGE



DIOTEC ELECTRONICS CORPORATION

SAMPLE REQUEST FORM

TO EXPEDITE YOUR REQUEST FOR PRODUCT SAMPLES, PLEASE FILL OUT THIS FORM AND FAX IT TO US AT:

310-767-7958

NOTE: DIOTEC ELECTRONICS CORP. IS A LEADING MANUFACTURER OF HIGH QUALITY, HIGH RELIABILITY POWER DIODES AND RECTIFIERS. WE SERVE THE OEM COMMUNITY. RETAIL REQUESTS SHOULD BE DIRECTED TO NTE ELECTRONICS (WWW.NTEINC.COM) OR DIGI-KEY (WWW.DIGIKEY.COM).

COMPANY :
ENGINEERING CONTACT:
CONTACT PHONE NUMBER:
CONTACT FAX NUMBER:
ADDRESS:
CITY
STATE

DIOTEC PART NUMBER(S):
NUMBER OF SAMPLES:
ESTIMATED ANNUAL USAGE:
TARGET PRICE:

APPLICATION:
NEW PRODUCT?
REDESIGN?
NEED ALTERNATE SUPPLIER?
CURRENT SUPPLIER:
CURRENT PART NUMBER
CURRENT PRICE:

COMMENTS:

APPENDIX IX - SOFT GLASS

Combining a unique passivation material and void free vacuum die soldering, the SOFT GLASS DIODE™ offers outstanding reliability under the harshest of operating conditions. The SOFT GLASS passivation material uniquely provides the diode with unmatched protect against the negative effects of aging, thermal/mechanical stress, and moisture. The features which clearly separate this material from the industry's standard glass or rubber passivation are shown in the table below.

<i>STRUCTURE</i>	<i>SOFT GLASS</i>	<i>RUBBER</i>	<i>STANDARD GLASS</i>
BOND ENERGY	Similar to Standard Glass For Low/High Temperature Stability	Weak	
TEMPERATURE RANGE	-100 to +250° C		
MECHANICAL INTEGRITY	Relieves Thermal & Mechanical Stresses	Rigid at Low Temperatures Ages Quickly at High Temperatures	Rigid And Brittle

Unlike the silicon rubber used in most low cost diodes, DIOTEC's SOFT GLASS is mostly inorganic. Similar to glass, the basic structure of SOFT GLASS consists of repeating Silicon-Oxygen (Si-O) segments. The greater bond energy, and hence stability, of the Si-O linkages, as opposed to that of a Carbon-Carbon (C-C) bond, enables SOFT GLASS to retain its high resiliency at temperatures as low as -100° C and is remarkably stable (mechanically and electrically) at continuous temperatures as high as 250° C.

When compared to glass, which is rigid and brittle, SOFT GLASS is flexible within the diode's operational temperature range. Therefore, it releases internal stresses caused by differences in the thermal expansion coefficients of the different materials used to construct a diode. As a result, SOFT GLASS protects diodes from the negative effects of aging, thermal/mechanical stresses, and moisture.

DIOTEC's SOFT GLASS DIODES are identified in the Super Efficient/Ultrafast Diode, General Purpose Diode, and Fast Recovery Diode Quick Selection Guides and applicable data sheets.

If you wish to try one or more of these diodes in your application, fill out the form in Appendix VIII or simply give us a call. Our phone number is at the bottom of the page.

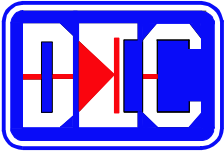

DIOTEC ELECTRONICS CORP

18020 Hobart Blvd., Unit B

Gardena, CA 90248 USA

Tel: (310) 767-1052 Fax: (310) 767-7958

web site: www.diotec-usa.com e-mail: productsupport@diotec-usa.com

DIOTEC is thriving while its competitors, big and small are dropping out!!

The reasons?? Very simple:

- (A) DIOTEC offers a very **comprehensive line** of diodes and rectifiers with excellent qualities.
- (B) DIOTEC offers the **Best Services** in the business:
 - (1) Same Day Price Quotation (*)**
 - (2) Samples delivered within three days (*)**
 - (3) Orders delivered from stock (*)**
- (C) DIOTEC is able and more willing to go the extra distance to assist you with your special requirements
- (D) DIOTEC offers the most competitive prices. Unlike its major competitors, DIOTEC runs the tightest ship and therefore has the lowest overhead in this business. This allows DIOTEC to keep its costs down and pass the savings on to its valued customers.

So discuss your diode and rectifier needs with DIOTEC now. Our knowledgeable sales and technical staffs are ready to help you.

THE ONLY QUALITY RECTIFIERS AND DIODES AT COMPETITIVE PRICES

(*) Except Specialty items