

CR3CM

LOW POWER USE
NON-INSULATED TYPE, GLASS PASSIVATION TYPE

CR3CM

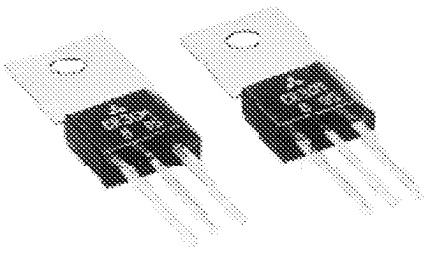

- I_T (AV) **3A**
- V_{DRM} **400V/600V**
- I_{GT} **200 μ A**

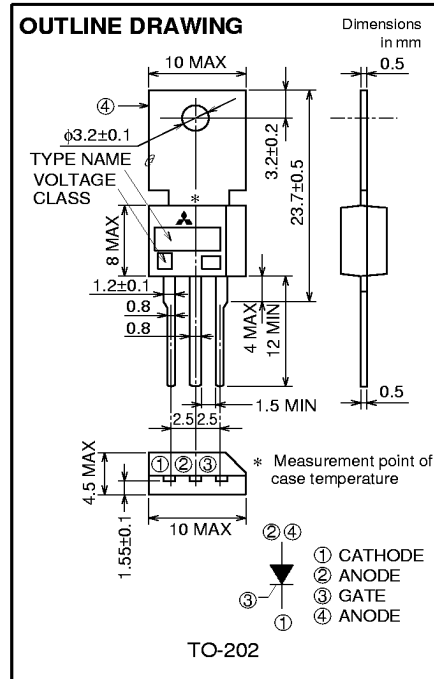

APPLICATION

TV sets, strobe flasher, ignitors, gas ignitor, static switch, other general purpose control applications

MAXIMUM RATINGS

Symbol	Parameter	Voltage class *1		Unit
		8	12	
V_{RRM}	Repetitive peak reverse voltage	400	600	V
V_{RSM}	Non-repetitive peak reverse voltage	500	720	V
V_R (DC)	DC reverse voltage	320	480	V
V_{DRM}	Repetitive peak off-state voltage	400	600	V
V_D (DC)	DC off-state voltage	320	480	V

Symbol	Parameter	Conditions	Ratings	Unit
I_T (RMS)	RMS on-state current		4.7	A
I_T (AV)	Average on-state current	Commercial frequency, sine half wave, 180° conduction, $T_c=50^\circ\text{C}$	3.0	A
I_{TSM}	Surge on-state current	60Hz sine half wave 1 full cycle, peak value, non-repetitive	90	A
I_{T1}	I_{T1} for fusing	Value corresponding to 1 cycle of half wave 60Hz, surge on-state current	33	A ² s
P_{GM}	Peak gate power dissipation		0.5	W
P_G (AV)	Average gate power dissipation		0.1	W
V_{FGM}	Peak gate forward voltage		6	V
V_{RGM}	Peak gate reverse voltage		6	V
I_{FGM}	Peak gate forward current		0.3	A
T_j	Junction temperature		-40 ~ +110	°C
T_{stg}	Storage temperature		-40 ~ +125	°C
—	Weight	Typical value	1.6	g

*1. With Gate-to-cathode resistance $R_{GK}=1\text{k}\Omega$.



CR3CM

LOW POWER USE
NON-INSULATED TYPE, GLASS PASSIVATION TYPE

ELECTRICAL CHARACTERISTICS

Symbol	Parameter	Test conditions	Limits			Unit
			Min.	Typ.	Max.	
IRRM	Repetitive peak reverse current	T _j =110°C, V _{RRM} applied	—	—	1.0	mA
IDRM	Repetitive peak off-state current	T _j =110°C, V _{DRM} applied, R _{GK} =1kΩ	—	—	1.0	mA
V _{TM}	On-state voltage	T _c =25°C, I _{TM} =10A, Instantaneous value	—	—	1.6	V
V _{GT}	Gate trigger voltage	T _j =25°C, V _D =6V, I _T =0.1A	—	—	0.8	V
V _{GD}	Gate non-trigger voltage	T _j =110°C, V _D =1/2V _{DRM} , R _{GK} =1kΩ	0.1	—	—	V
I _{GT}	Gate trigger current	T _j =25°C, V _D =6V, I _T =0.1A	1	—	200*3	μA
R _{th(j-c)}	Thermal resistance	Junction to case *2	—	—	10	°C/W

*2. The method point for case temperature is at anode tab 1.5mm away from the molded case.

*3. If special values of I_{GT} are required, choose at least two items from those listed in the table below. (Example: AB, B~D)

Item	A	B	C	D
I _{GT} (μA)	1 ~ 30	20 ~ 50	40 ~ 100	80 ~ 200

The above values do not include the current flowing through the 1kΩ resistance between the gate and cathode.

PERFORMANCE CURVES

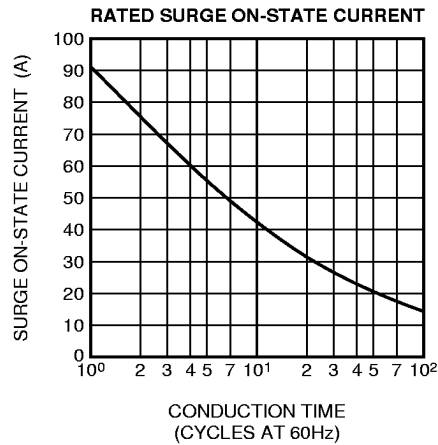
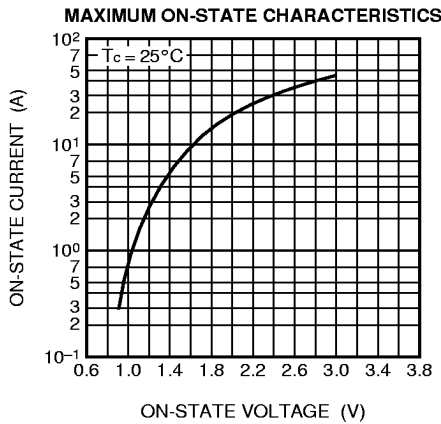

Feb.1999



CR3CM

LOW POWER USE
NON-INSULATED TYPE, GLASS PASSIVATION TYPE

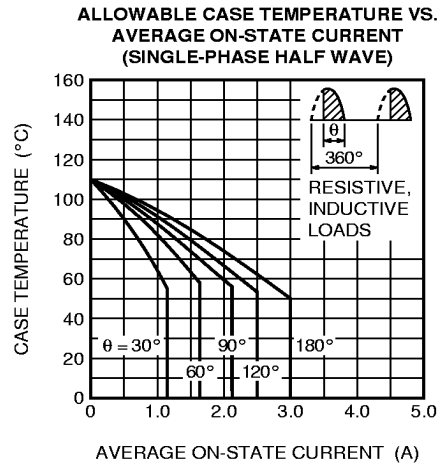
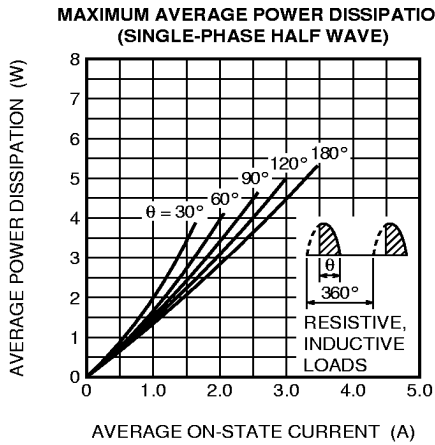
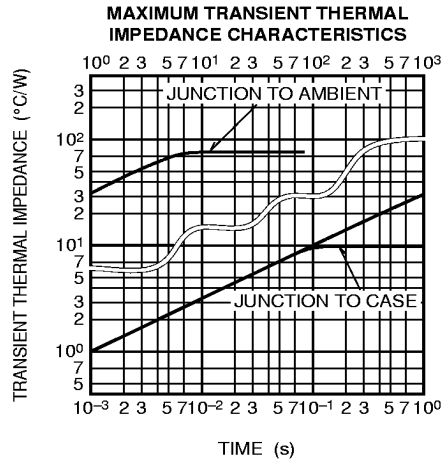
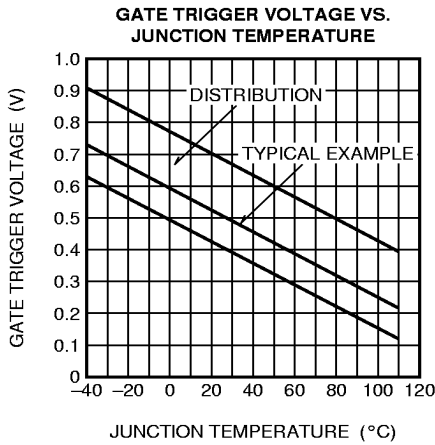
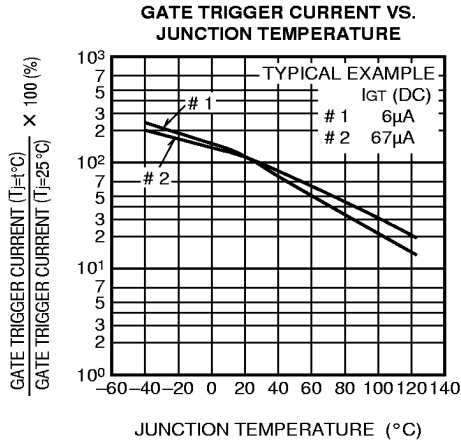
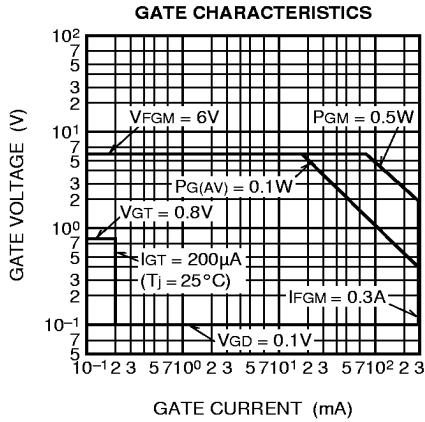

CR3CM

LOW POWER USE

NON-INSULATED TYPE, GLASS PASSIVATION TYPE

ALLOWABLE AMBIENT TEMPERATURE VS. AVERAGE ON-STATE CURRENT (SINGLE-PHASE HALF WAVE)

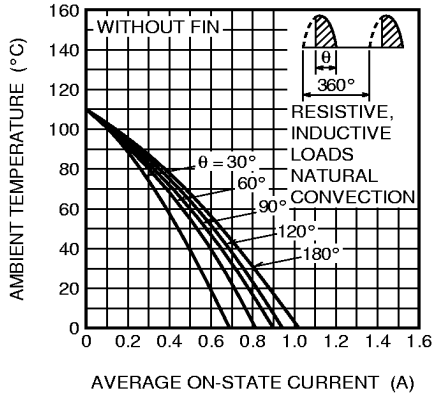

ALLOWABLE AMBIENT TEMPERATURE VS. AVERAGE ON-STATE CURRENT (SINGLE-PHASE HALF WAVE)

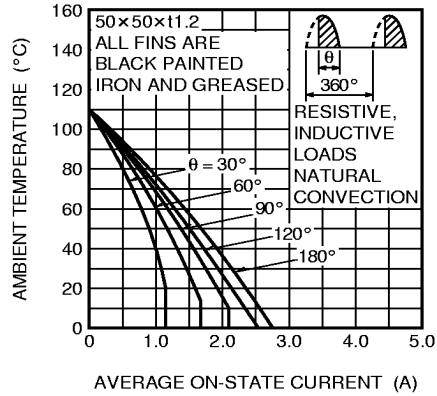

MAXIMUM AVERAGE POWER DISSIPATION (SINGLE-PHASE FULL WAVE)

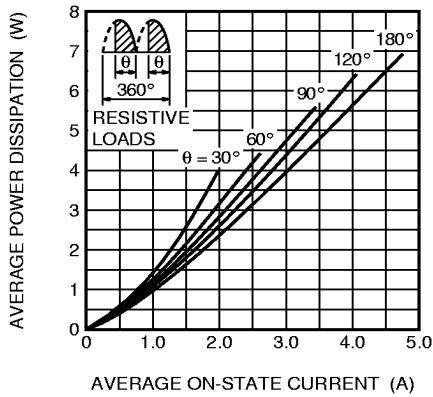

ALLOWABLE CASE TEMPERATURE VS. AVERAGE ON-STATE CURRENT (SINGLE-PHASE FULL WAVE)

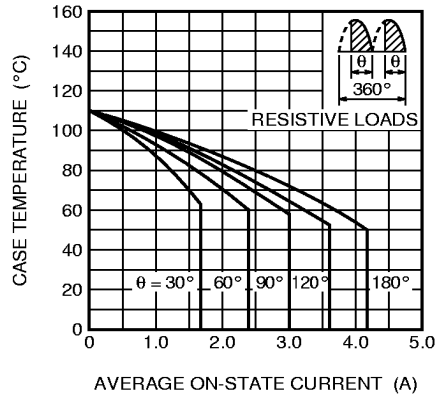

ALLOWABLE AMBIENT TEMPERATURE VS. AVERAGE ON-STATE CURRENT (SINGLE-PHASE FULL WAVE)

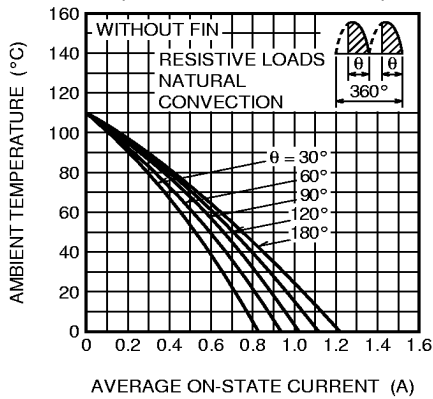

ALLOWABLE AMBIENT TEMPERATURE VS. AVERAGE ON-STATE CURRENT (SINGLE-PHASE FULL WAVE)

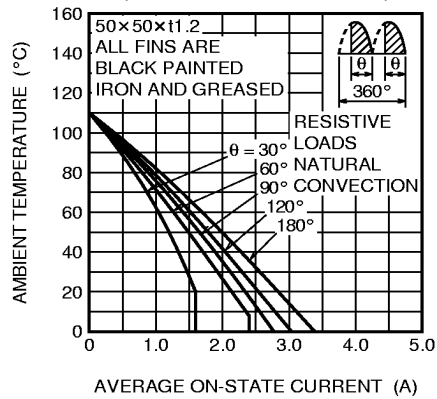

CR3CM

LOW POWER USE
NON-INSULATED TYPE, GLASS PASSIVATION TYPE

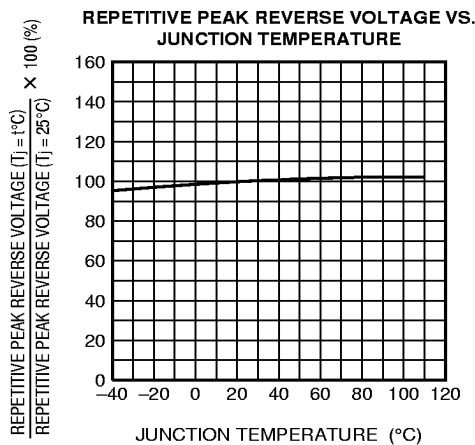
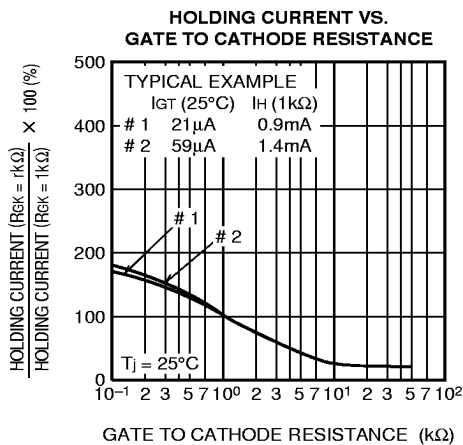
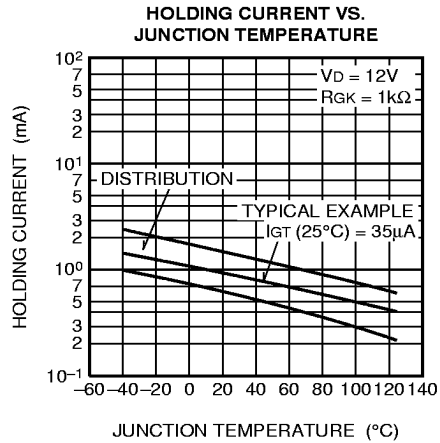
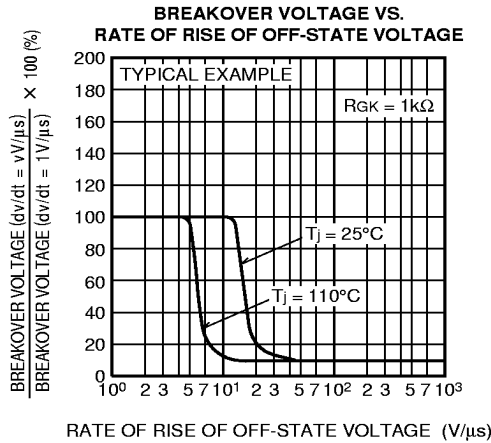
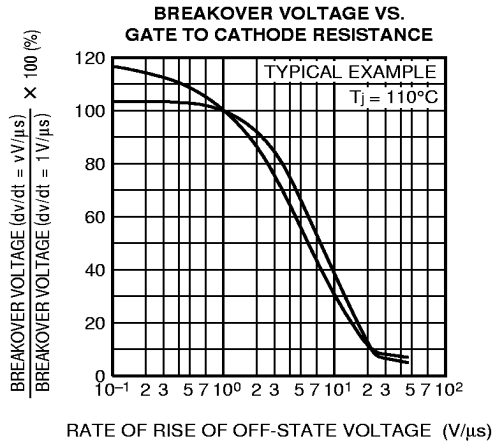
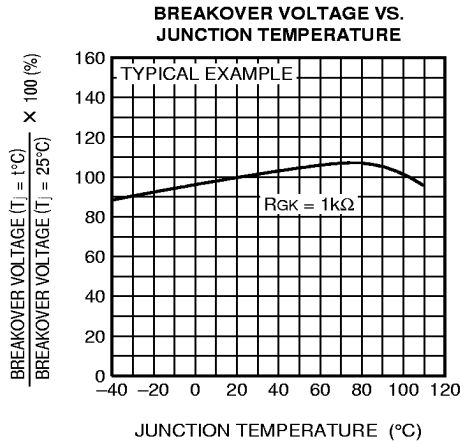

CR3CM

LOW POWER USE

NON-INSULATED TYPE, GLASS PASSIVATION TYPE

