

SHINDENGEN

Schottky Rectifiers (SBD)

Single

D1FM3

30V 5A

OUTLINE DIMENSIONS

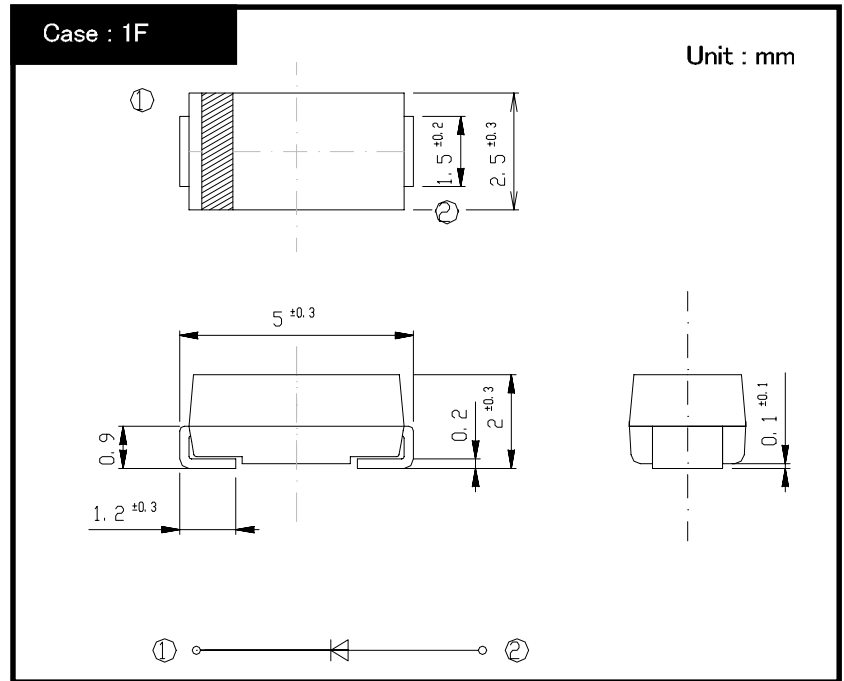

RATINGS

● Absolute Maximum Ratings (Tc=25°C)

Item	Symbol	Conditions	Ratings	Unit
Storage Temperature	Tstg		-55~150	°C
Operating Junction Temperature	Tj		150	°C
Maximum Reverse Voltage	VRM		30	V
Average Rectified Forward Current	Io	50Hz sine wave, R-load Ta=25°C On glass-epoxy substrate	3.0	A
		50Hz sine wave, R-load Tc=83°C	5.0	
Peak Surge Forward Current	IFSM	50Hz sine wave, Non-repetitive 1 cycle peak value, Tc=25°C	90	A

● Electrical Characteristics Tc=25°C

Item	Symbol	Conditions	Ratings	Unit
Forward Voltage	VF1	IF=1.0A, Pulse measurement	Max.0.40	V
	VF2	IF=3.0A, Pulse measurement	Max.0.46	
Reverse Current	IR	VR=VRM, Pulse measurement	Max.0.1	mA
Junction Capacitance	Cj	f=1MHz, VR=10V	Typ.130	pF
Thermal Resistance	θjc	junction to case	Max.16	°C/W
	θjl	junction to lead	Max.18	
	θja	junction to ambient On glass-epoxy substrate	Max.65	

D1FM3

Forward Voltage

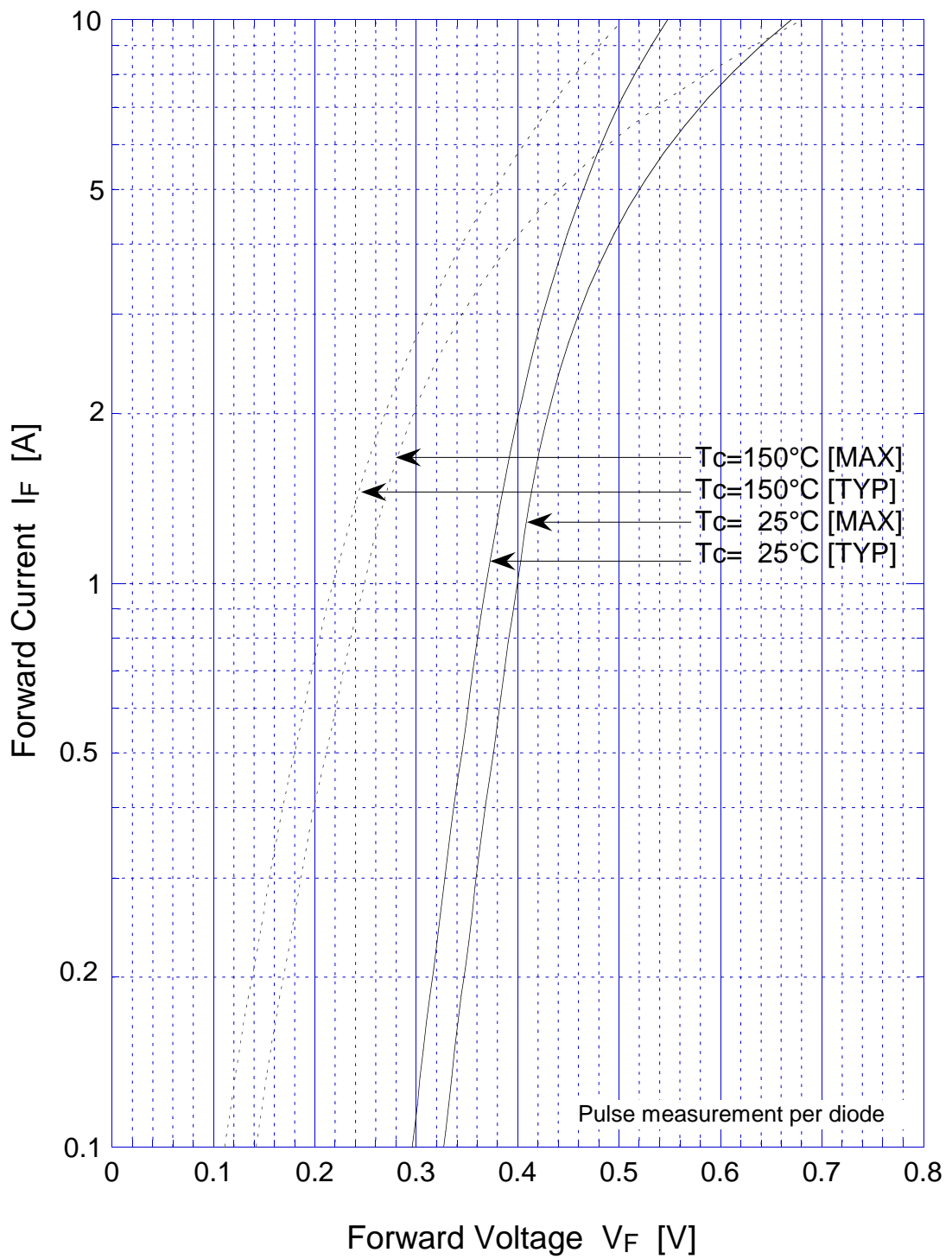

D1FM3 Forward Power Dissipation

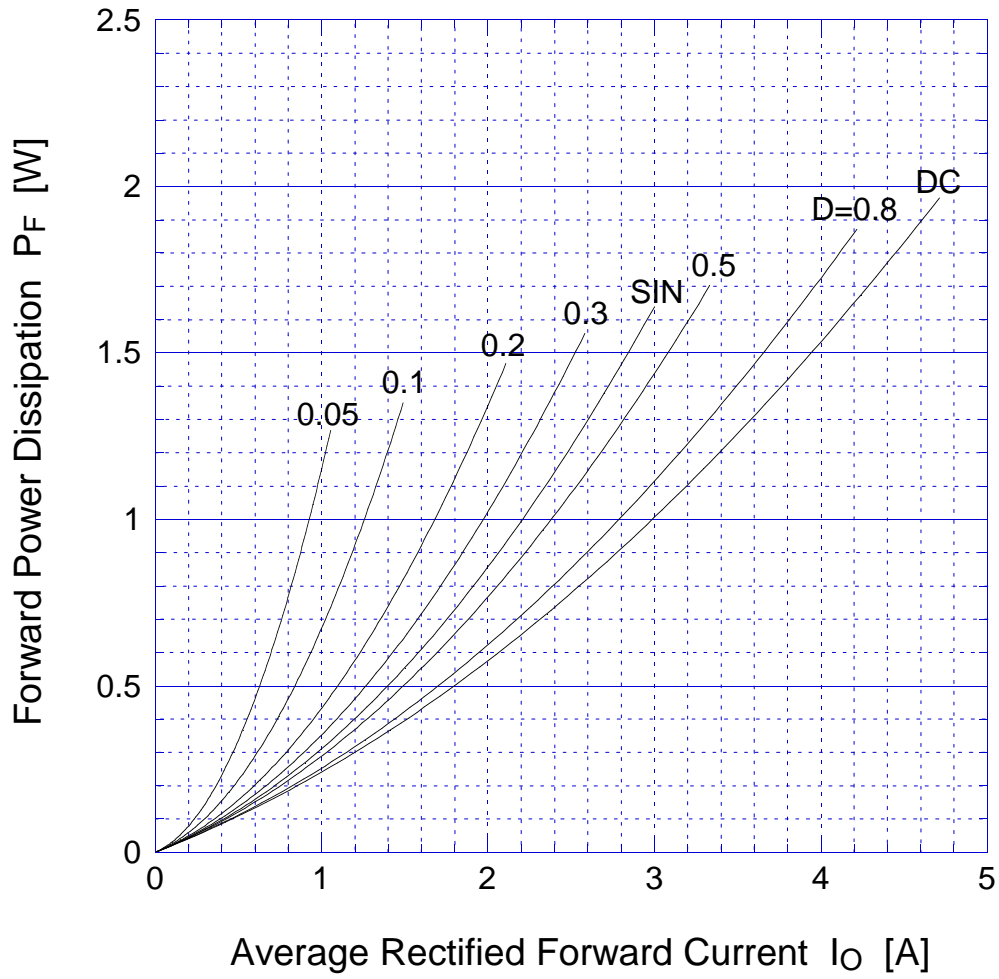

$T_j = 150^\circ\text{C}$

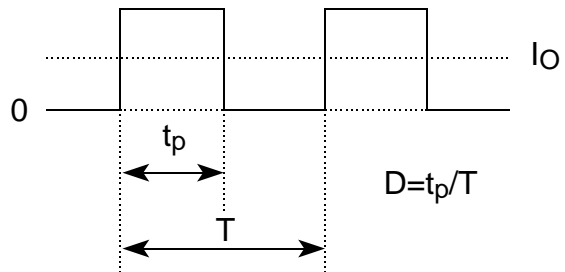

D1FM3

Peak Surge Forward Capability

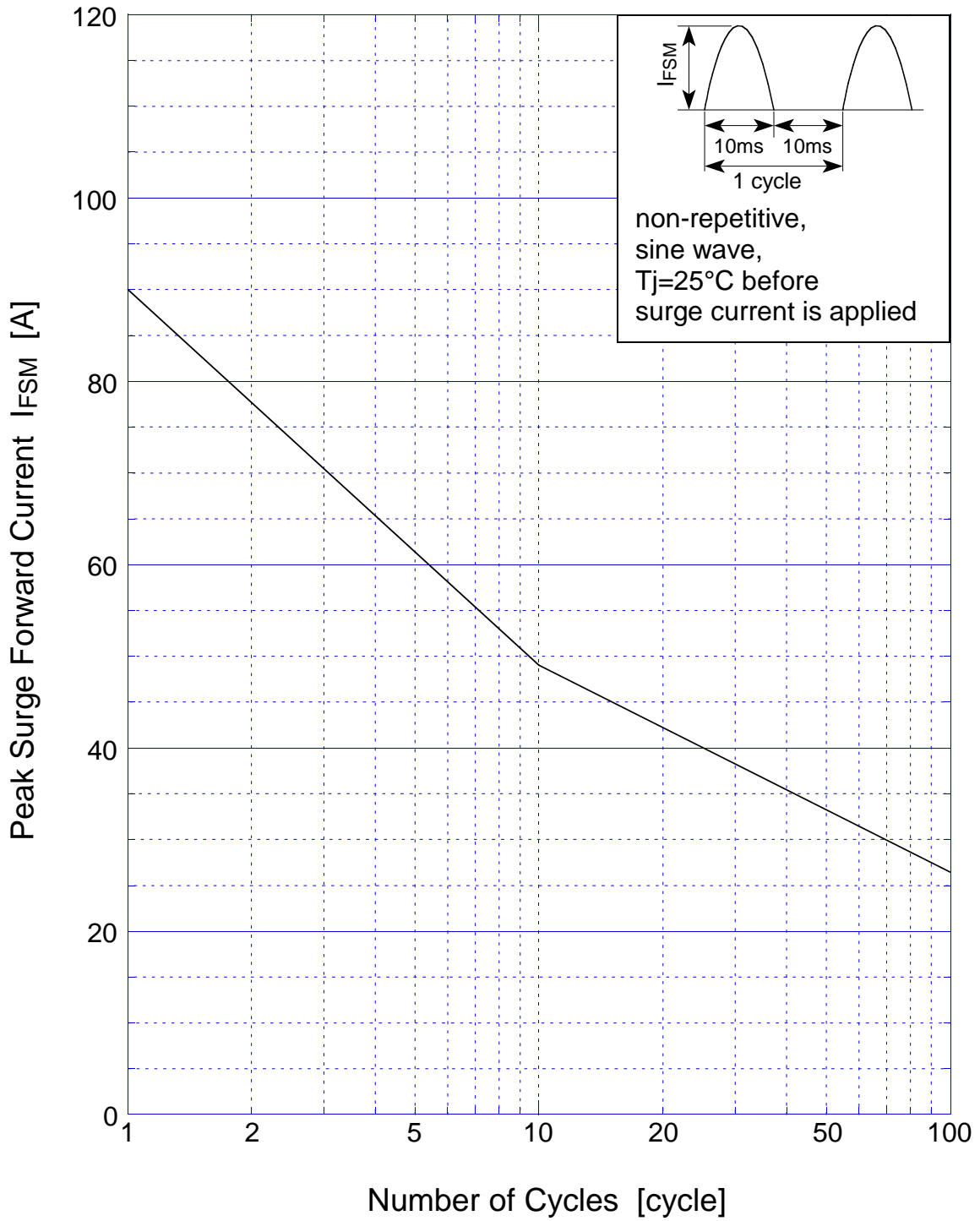

D1FM3

Reverse Current

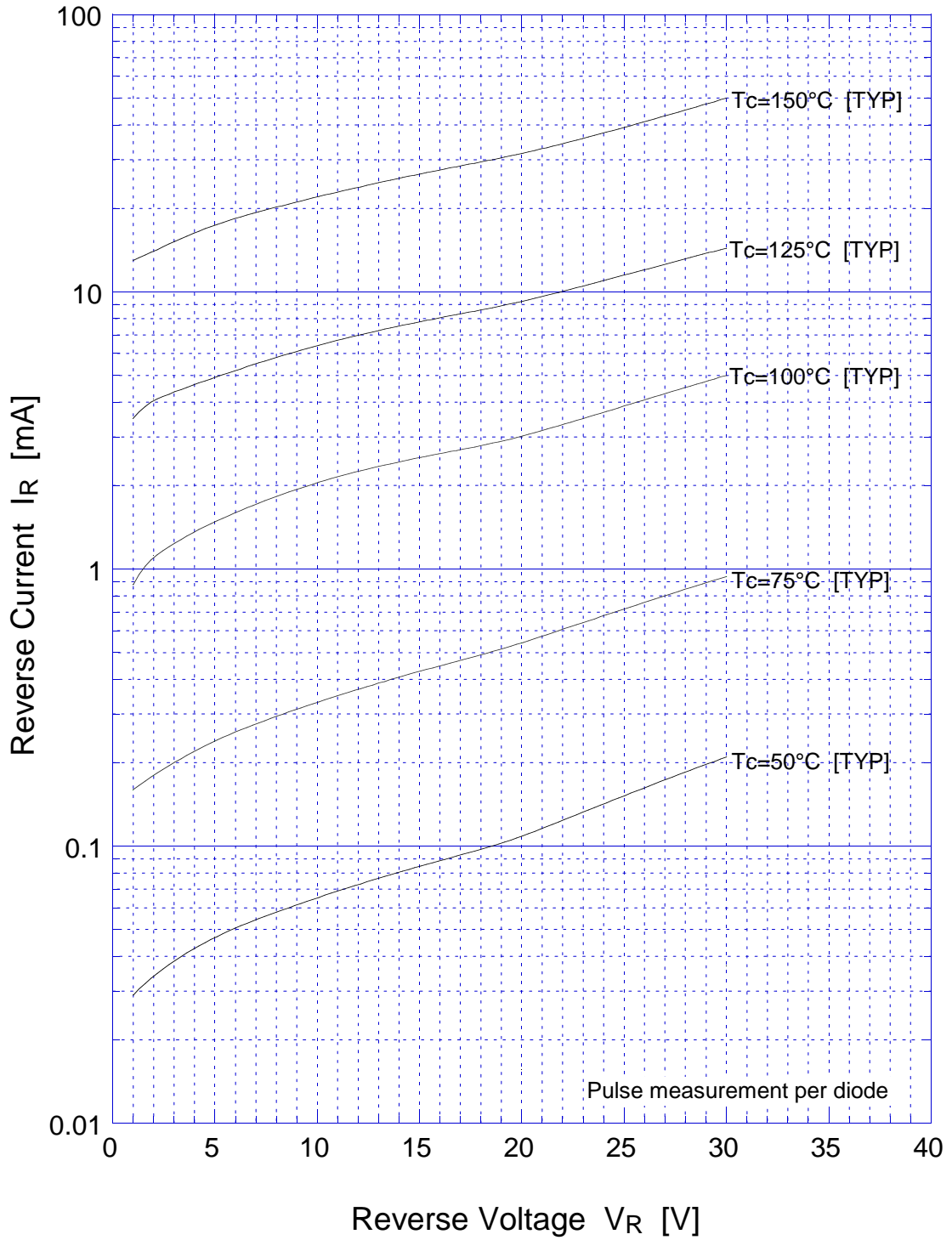

D1FM3

Reverse Power Dissipation

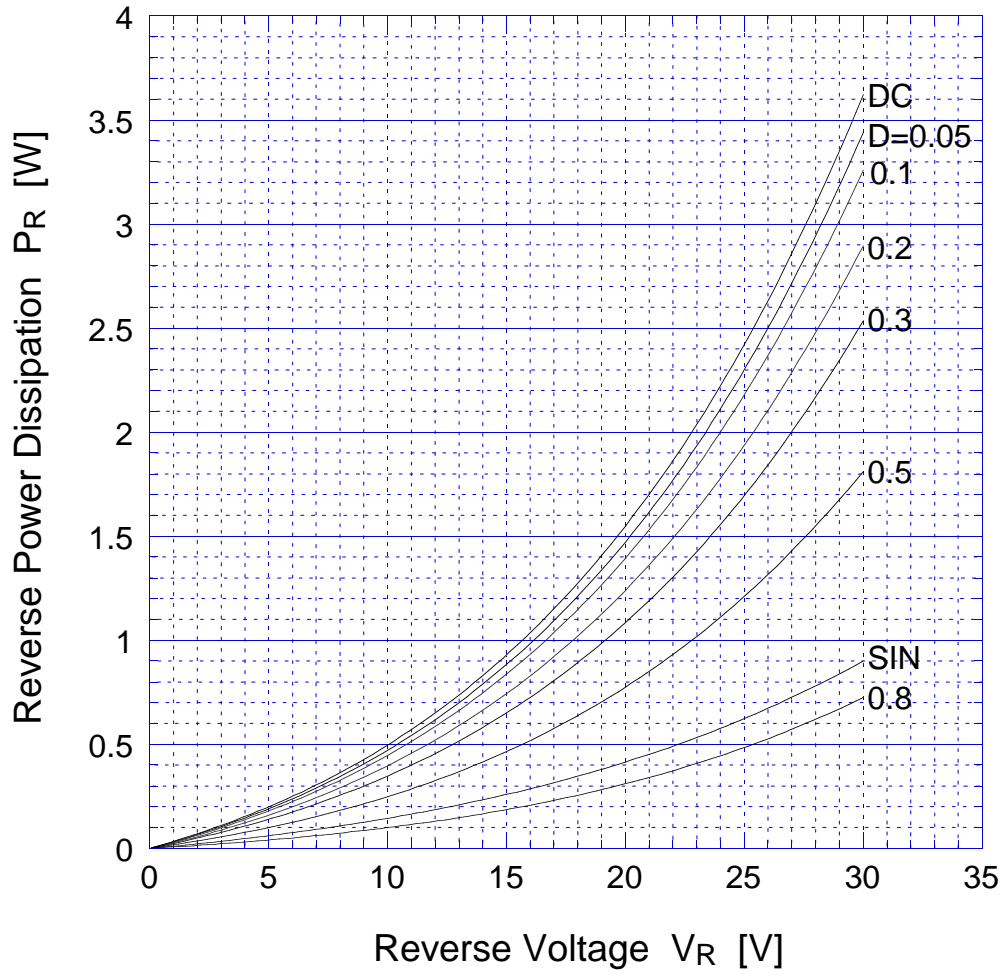

$T_j = 150^\circ\text{C}$

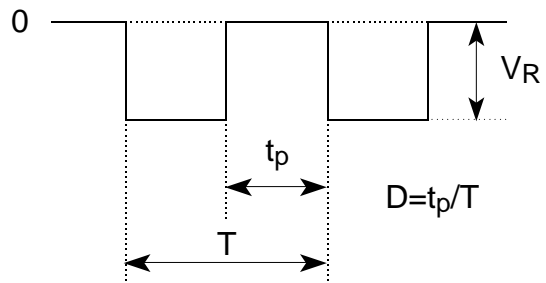

D1FM3 Junction Capacitance

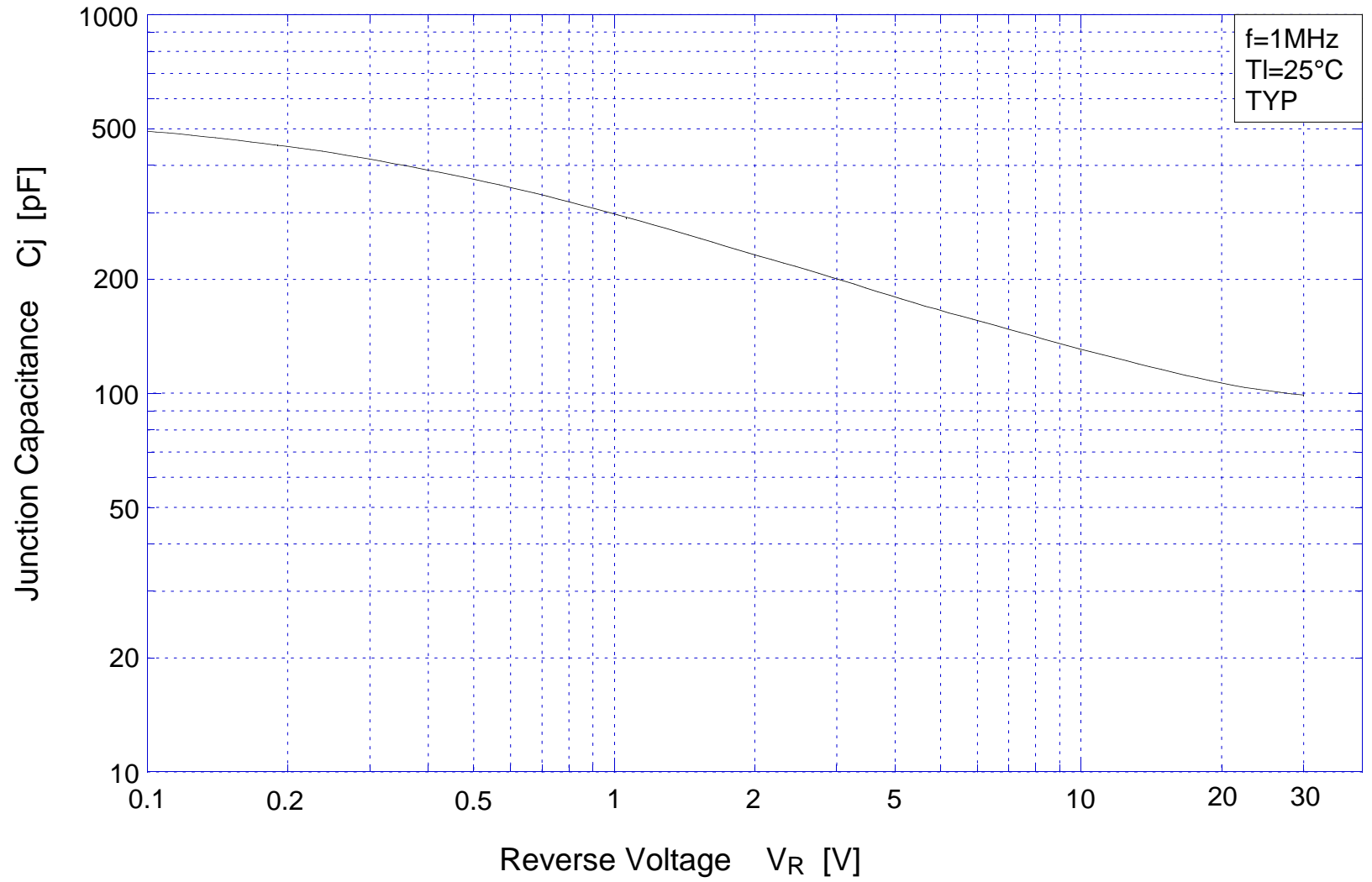

D1FM3

Derating Curve

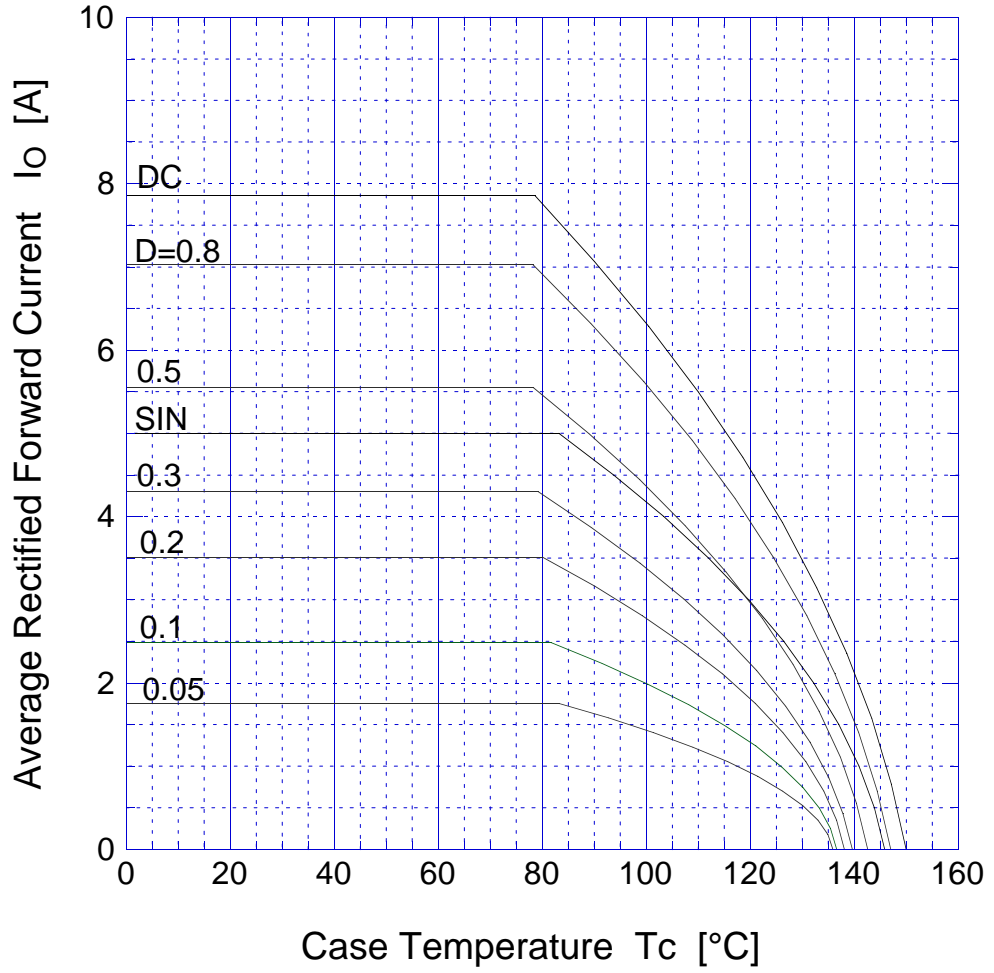

$V_R = 15V$

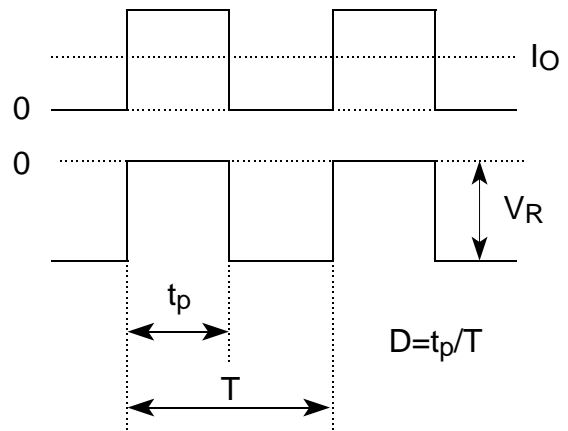

D1FM3

Derating Curve

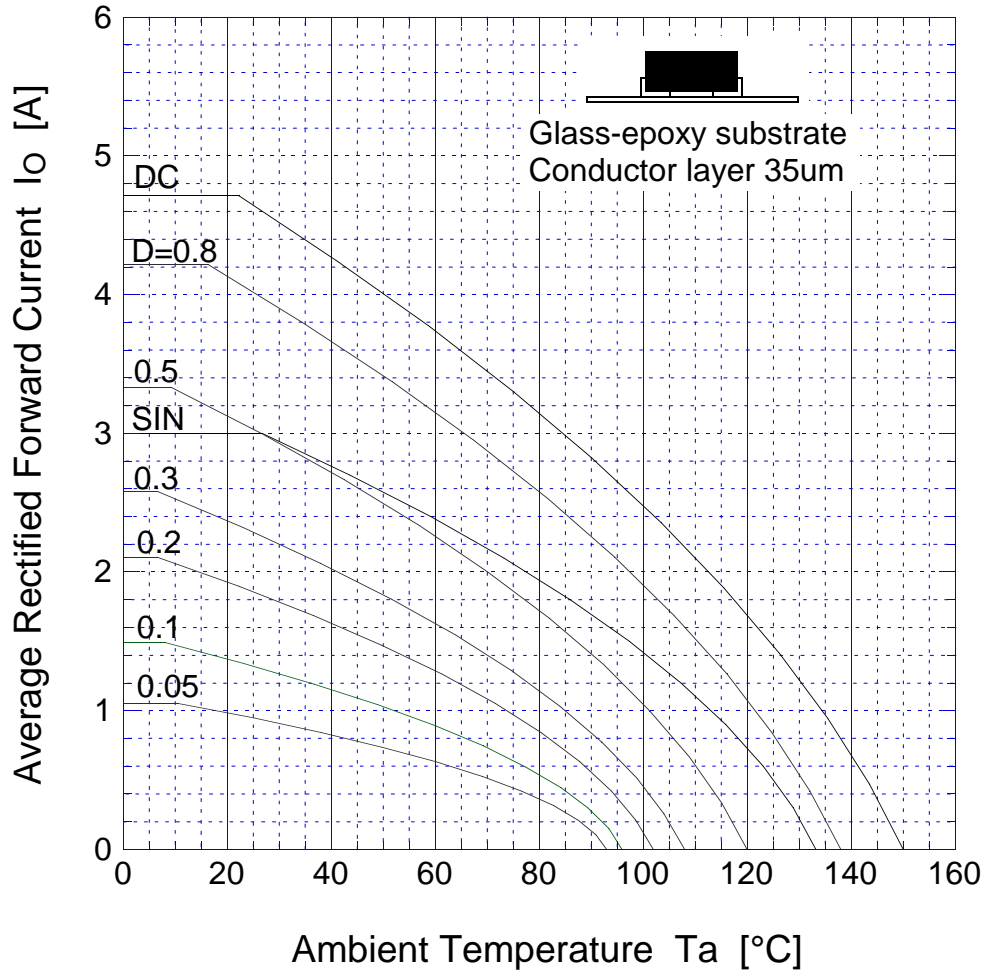

$V_R = 15V$

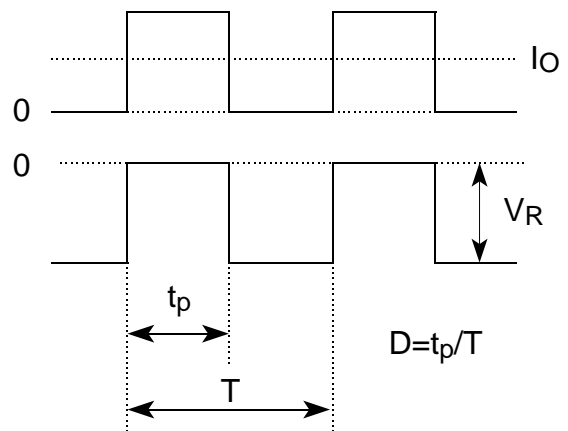

D1FM3

Derating Curve

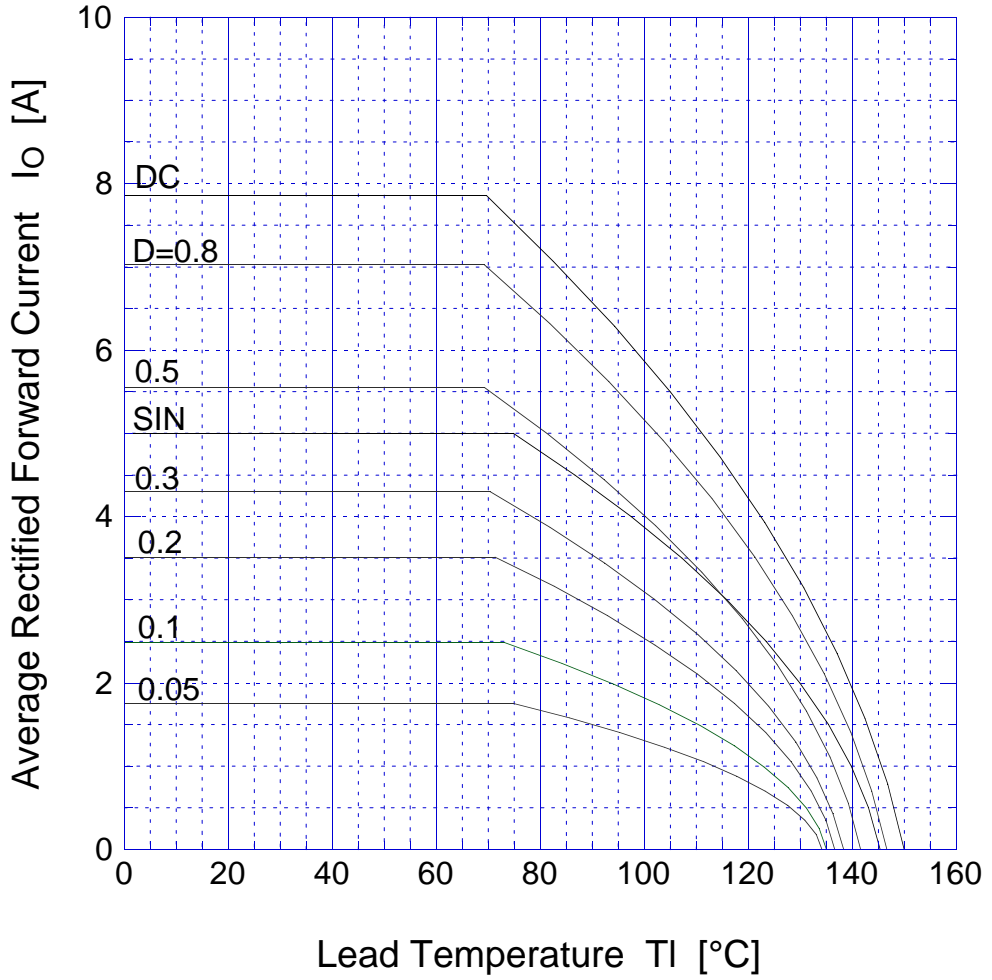

$V_R = 15V$

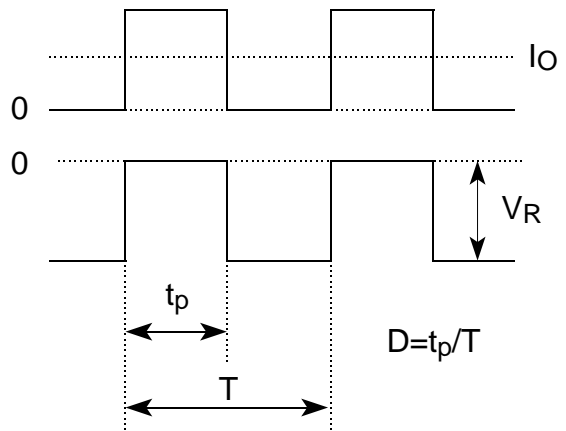

D1FM3 Transient Thermal Impedance

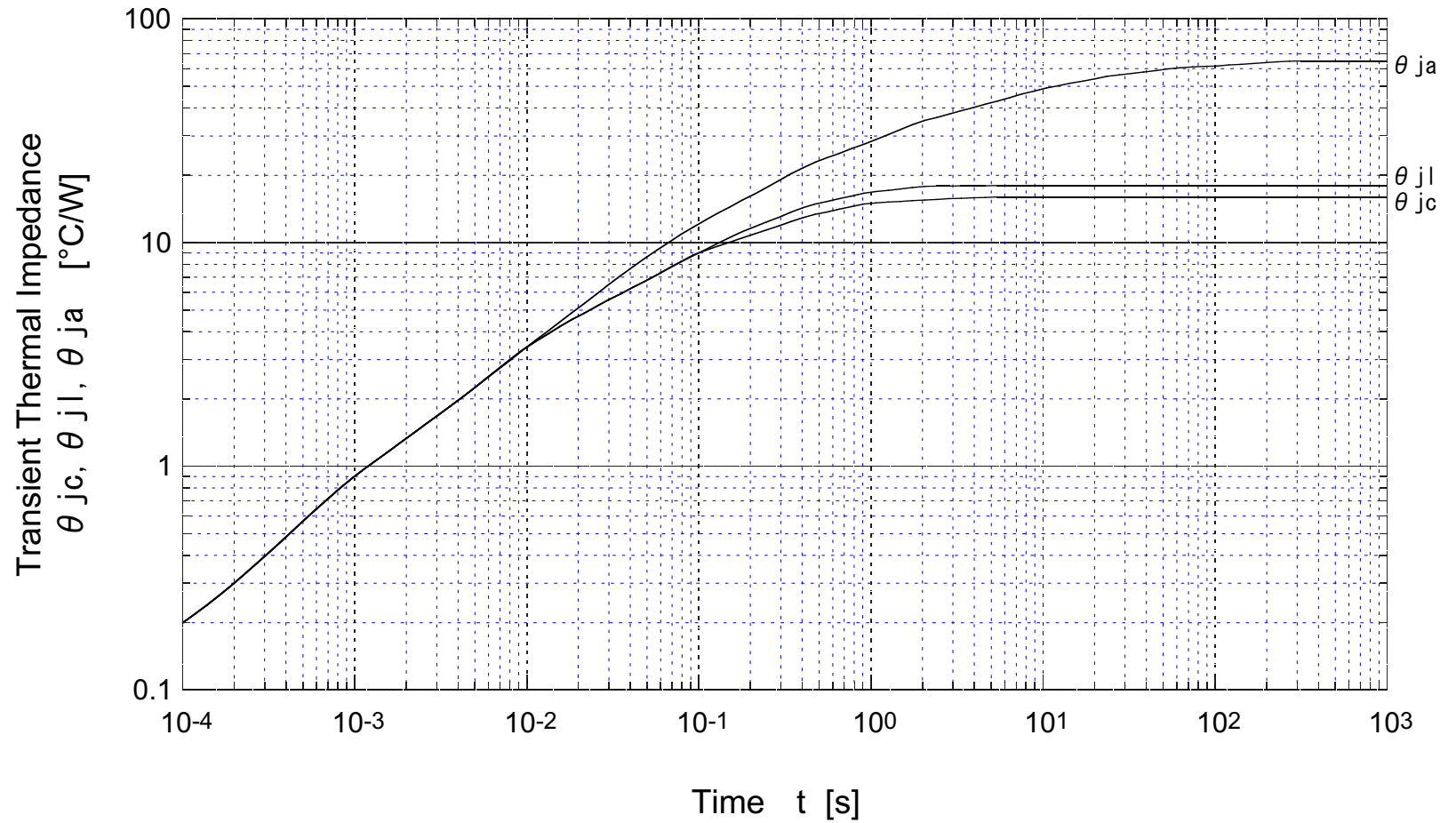

D1FM3 θ_{ja} - Conductor pattern area

