

D20LC20U

200V 20A

特長

- 低ノイズ
- trr 35ns
- フルモールド

用途

- SR電源
- フライホイール
- 家電、OA、FA

外形寸法図 OUTLINE DIMENSIONS

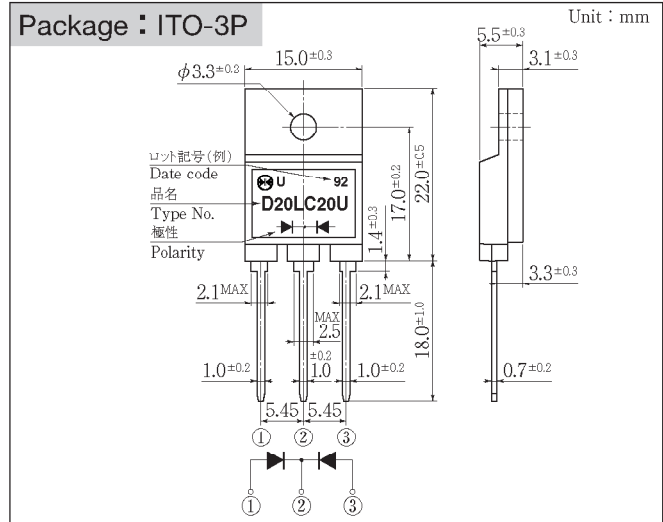

(製品上の表示については捺印仕様をご確認ください)

定格表 RATINGS

●絶対最大定格 Absolute Maximum Ratings (指定のない場合 $T_c = 25^\circ\text{C}$)

項目 Item	記号 Symbol	条件 Conditions	品名 Type No.	D20LC20U	単位 Unit
保存温度 Storage Temperature	Tstg			-40~150	°C
接合部温度 Operating Junction Temperature	Tj			150	°C
せん頭逆電圧 Maximum Reverse Voltage	V _{RM}			200	V
出力電流 Average Rectified Forward Current	I _o	50Hz正弦波, 抵抗負荷, 1素子当りの出力電流平均値 I _o /2, T _c = 112°C 50Hz sine wave, R-load, Rating for each diode I _o /2, T _c = 112°C		20	A
せん頭サーージ順電流 Peak Surge Forward Current	I _{FSM}	50Hz正弦波, 非繰り返し1サイクルせん頭値, T _j = 25°C 50Hz sine wave, Non-repetitive 1 cycle peak value, T _j = 25°C		150	A
絶縁耐圧 Dielectric Strength	V _{dis}	一括端子・ケース間, AC1分間印加 Terminals to case, AC 1 minute		1.5	kV
締め付けトルク Mounting Torque	TOR	(推奨値: 0.5N·m) (Recommended torque: 0.5N·m)		0.8	N·m

●電氣的・熱的特性 Electrical Characteristics (指定のない場合 $T_c = 25^\circ\text{C}$)

順電圧 Forward Voltage	V _F	I _F = 10 A, パルス測定, 1素子当りの規格値 Pulse measurement, Rating of per diode		MAX 0.98	V
逆電流 Reverse Current	I _R	V _R = V _{RM} , パルス測定, 1素子当りの規格値 Pulse measurement, Rating of per diode		MAX 10	μA
逆回復時間 Reverse Recovery Time	trr	I _F = 0.5 A, I _R = 1 A, 1素子当りの規格値 Rating of per diode		MAX 35	ns
熱抵抗 Thermal Resistance	θ _{jc}	接合部・ケース間 Junction and case		MAX 1.7	°C/W

■特性図 CHARACTERISTIC DIAGRAMS

