

# SHINDENGEN

## Super Fast Recovery Rectifiers

Single

# D3L60

## 600V 3A

### FEATURES

- High Voltage
- trr50ns
- Fully Isolated Molding
- Dielectric strength 1.5kV guaranteed

### APPLICATION

- PFC
- Switching power supply
- Free Wheel
- CTV+B output, lighting

### OUTLINE DIMENSIONS

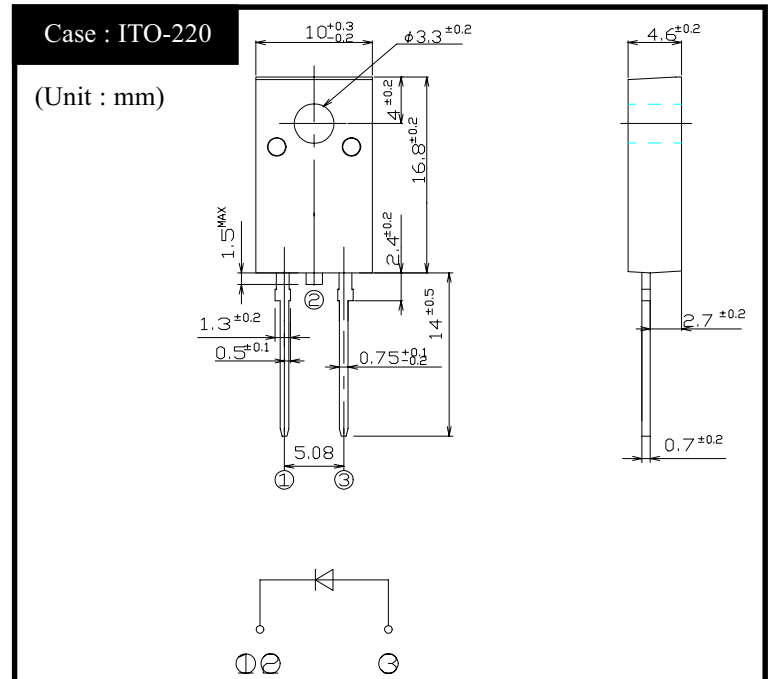

### RATINGS

#### ● Absolute Maximum Ratings (If not specified Tc=25°C)

Item	Symbol	Conditions	Ratings	Unit
Storage Temperature	T <sub>stg</sub>		-55~150	°C
Operating Junction Temperature	T <sub>j</sub>		150	°C
Maximum Reverse Voltage	V <sub>RM</sub>		600	V
Average Rectified Forward Current	I <sub>O</sub>	50Hz sine wave, R-load, T <sub>c</sub> =127°C	3	A
Peak Surge Forward Current	I <sub>FSM</sub>	50Hz sine wave, Non-repetitive 1 cycle peak value, T <sub>j</sub> =25°C	60	A
Dielectric Strength	V <sub>dis</sub>	Terminals to case, AC 1 minute	1.5	kV
Mounting Torque	TOR	(Recommended torque:0.3N·m)	0.5	N·m

#### ● Electrical Characteristics (If not specified Tc=25°C)

Item	Symbol	Conditions	Ratings	Unit
Forward Voltage	V <sub>F</sub>	I <sub>F</sub> =3A, Pulse measurement	Max.1.65	V
Reverse Current	I <sub>R</sub>	V <sub>R</sub> =V <sub>RM</sub> , Pulse measurement	Max.10	μA
Reverse Recovery Time	trr	I <sub>F</sub> =0.5A, I <sub>R</sub> =1A	Max.50	ns
Thermal Resistance	θ <sub>jc</sub>	junction to case	Max.4.5	°C/W
	θ <sub>jf</sub>	junction to heat-sink	Max.6	
	θ <sub>ja</sub>	junction to ambient	Max.55	

# D3L60

# Forward Voltage

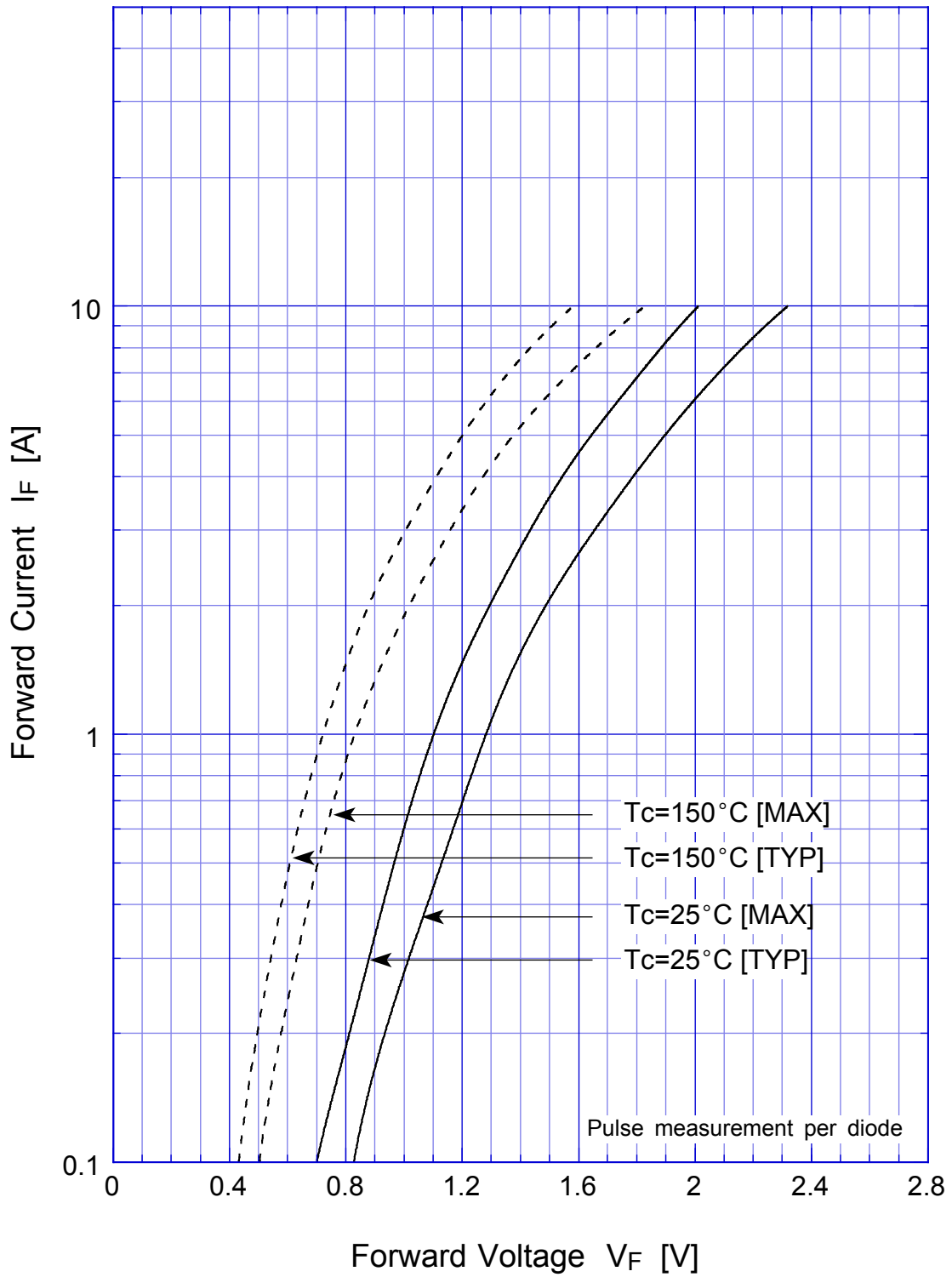

# D3L60

## Forward Power Dissipation

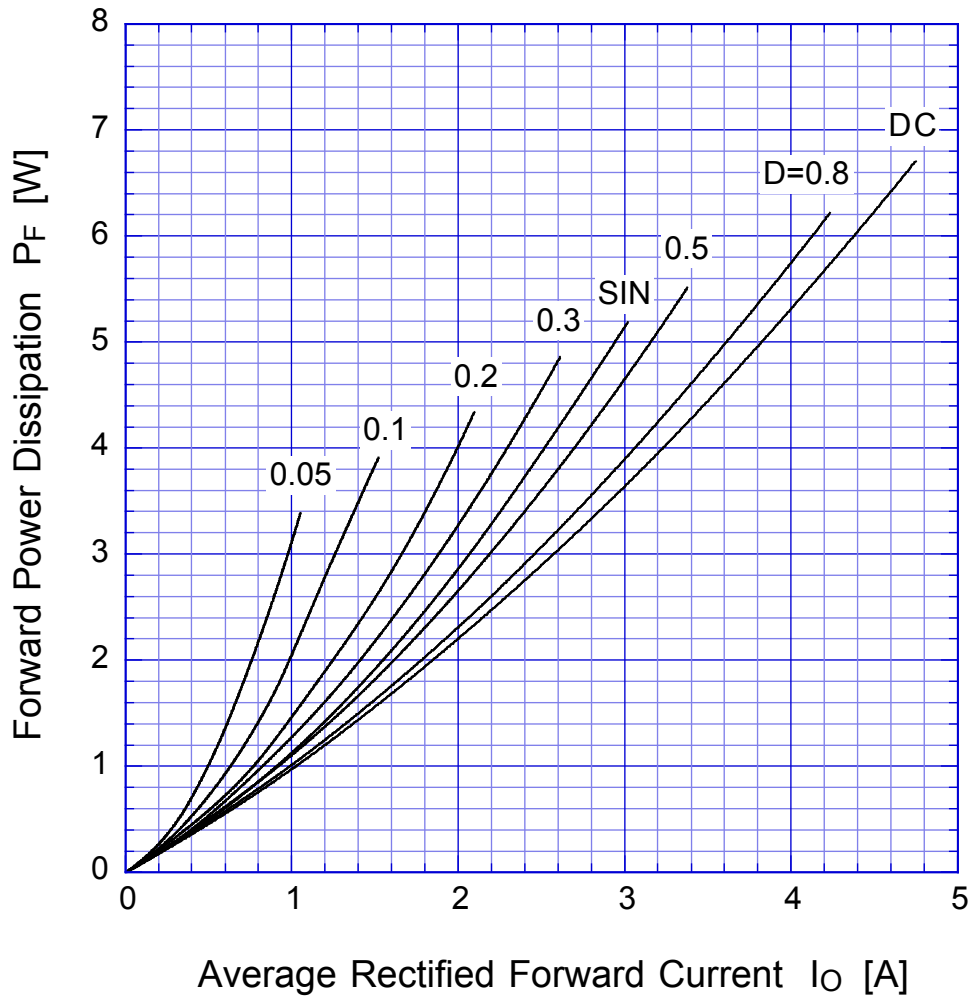

$T_j = T_{jmax}$

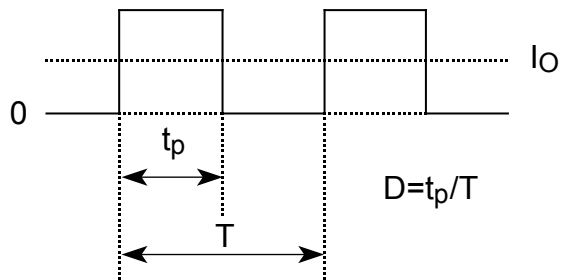

# D3L60

# Derating Curve

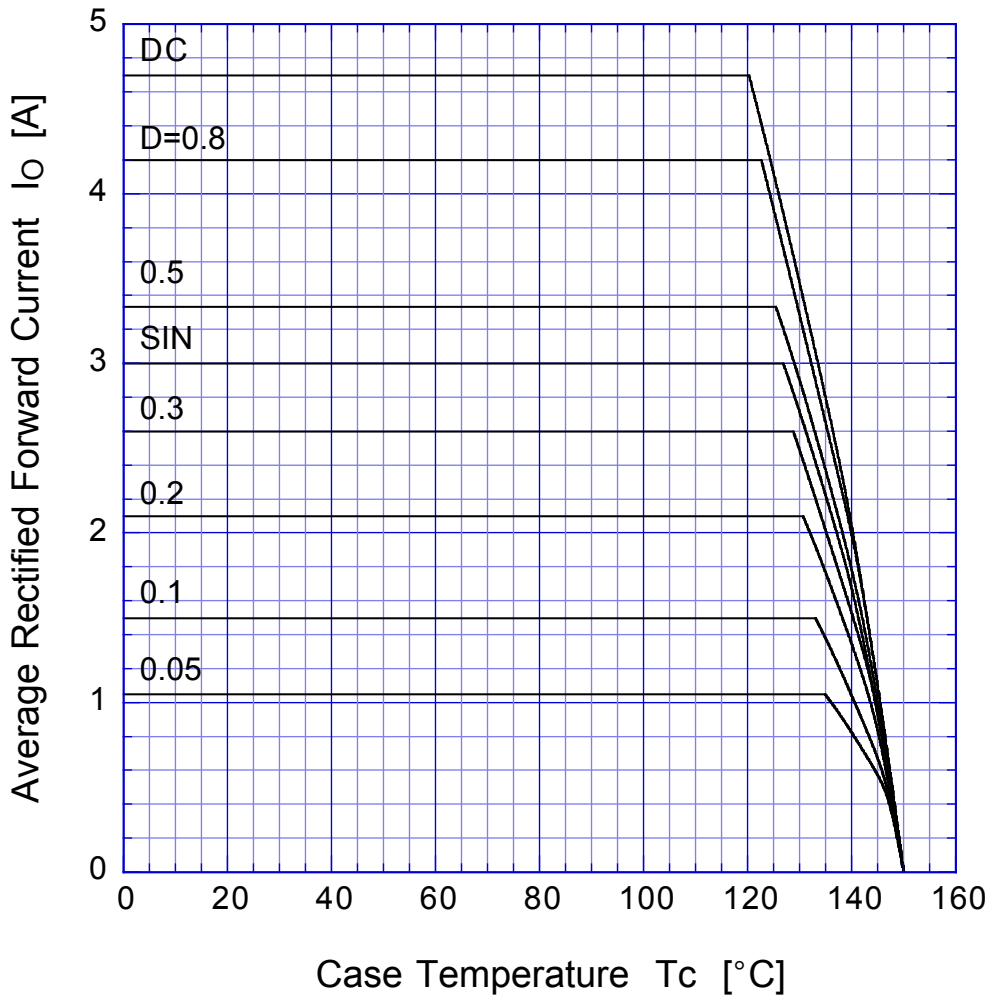

$$V_R = V_{RM}$$



# D3L60

# Derating Curve

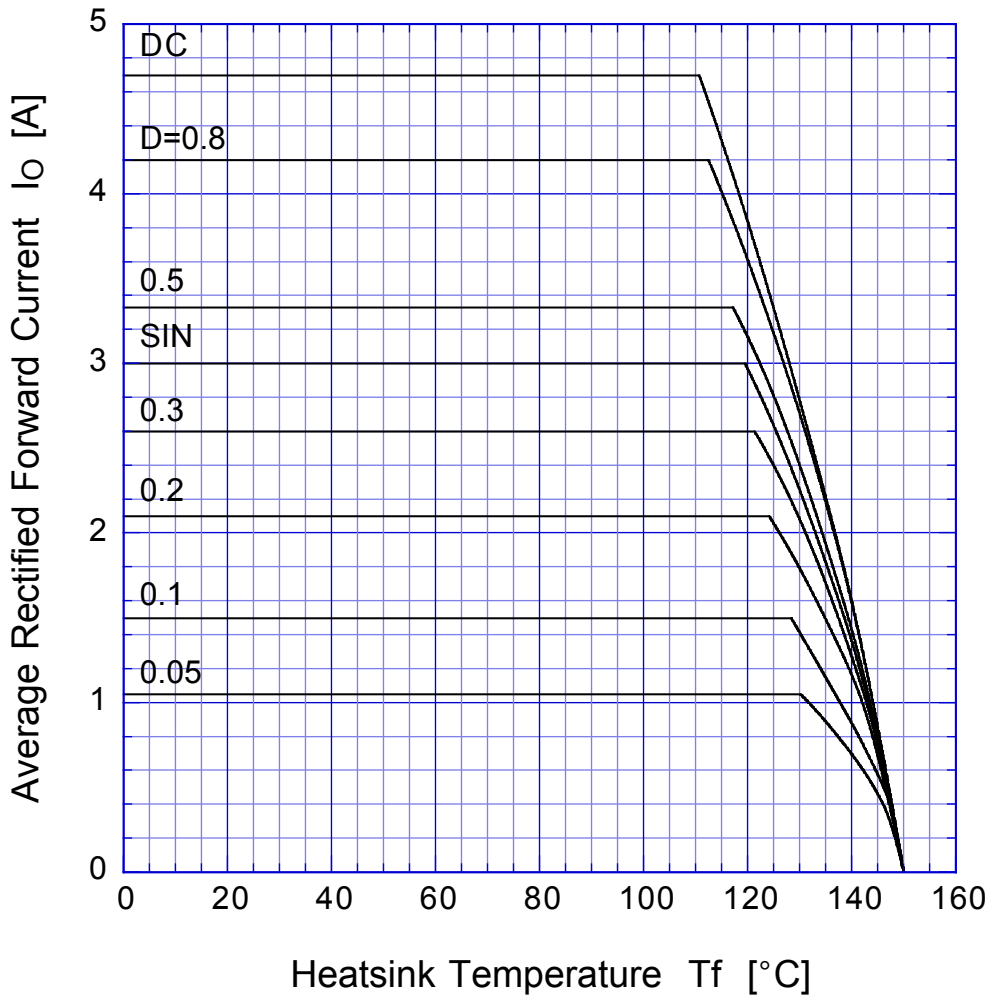

$$V_R = V_{RM}$$

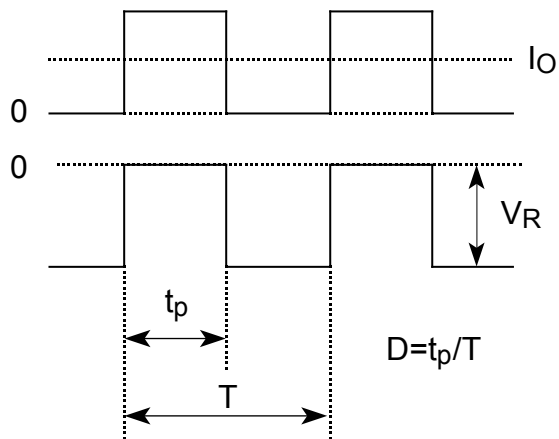

# D3L60

# Peak Surge Forward Capability

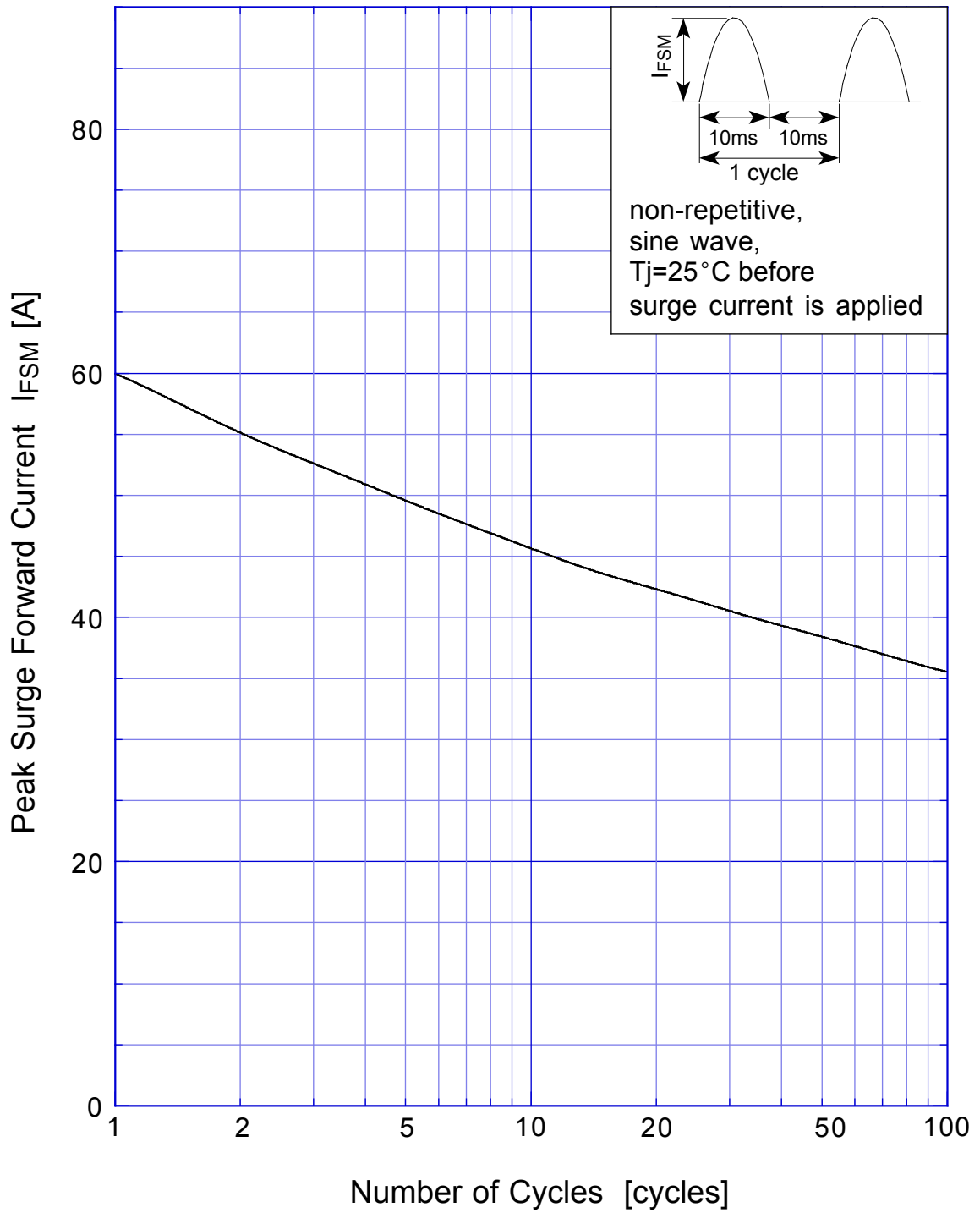

# D3L60

## Junction Capacitance

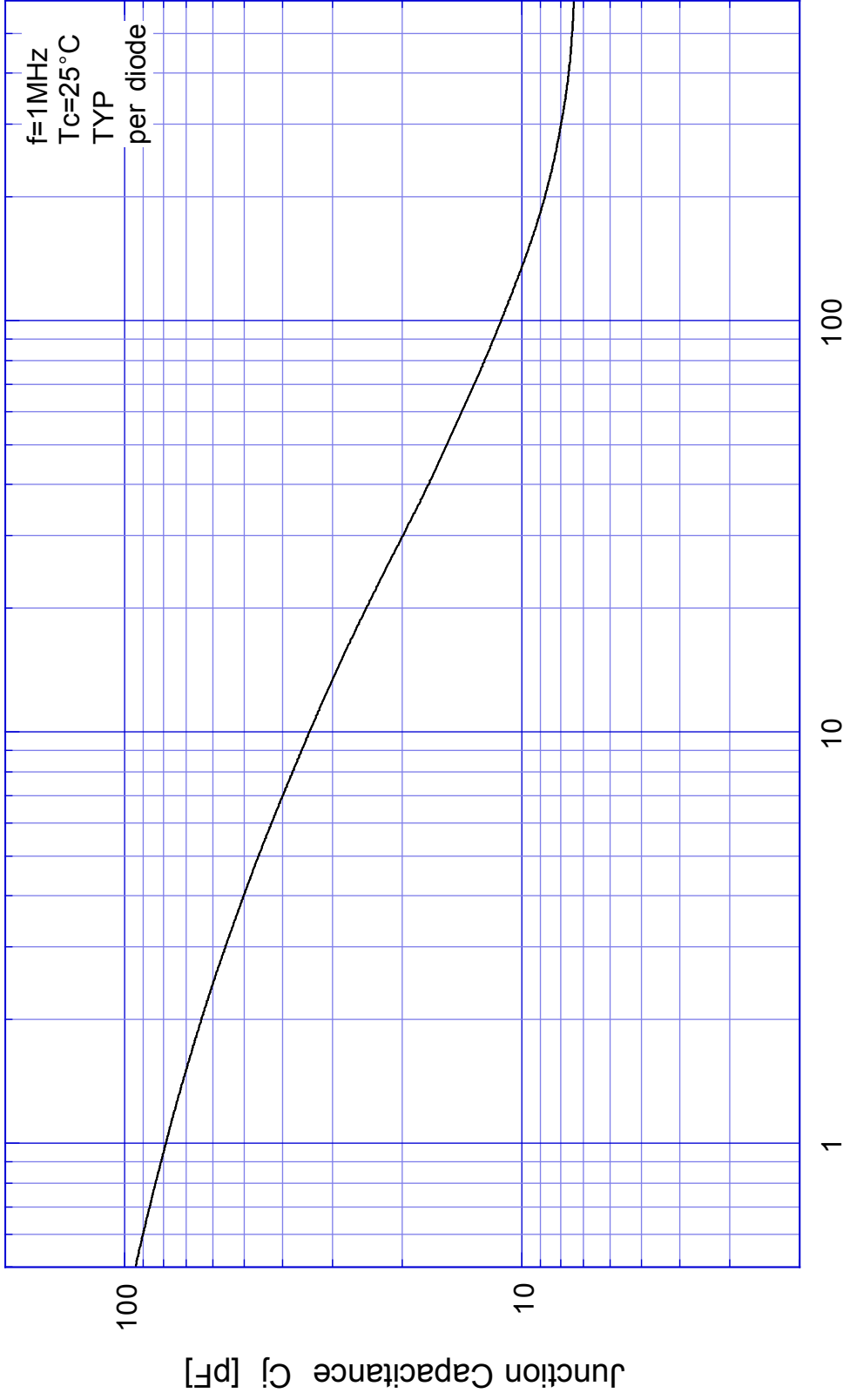

Reverse Voltage  $V_R$  [V]