



VERY HIGH GAIN NPN POWER DARLINGTON TRANSISTORS

COMPLEMENTARY TO THE D45D SERIES

D44D Series

40-80 VOLTS
6 AMP, 30 WATTS

The General Electric D44D is a Darlington power transistor. It is designed for general purpose switching of multi-ampere loads directly from low level logic circuitry. A monolithic bias resistor is included for elevated temperature stability and bypass diode for reduced dissipation under negative transient conditions.

Applications:

- Solenoid Driver
- Lamp Driver
- Relay Substitute
- Switching Regulator
- Inverter/Converter

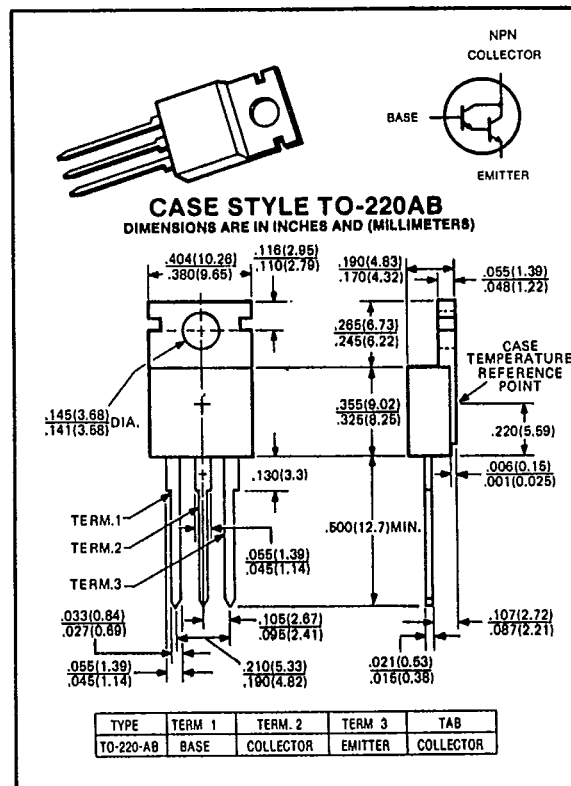

maximum ratings ($T_A = 25^\circ\text{C}$) (unless otherwise specified)

RATING	SYMBOL	D44D1,2	D44D3,4	D44D5,6	UNITS
Collector-Emitter Voltage	V_{CEO}	40	60	80	Volts
Collector-Emitter Voltage	V_{CES}	50	70	90	Volts
Emitter Base Voltage	V_{EBO}	5	5	5	Volts
Collector Current — Continuous	I_C	6	6	6	A
Base Current — Continuous	I_B	.5	.5	.5	A
Total Power Dissipation @ $T_A = 25^\circ\text{C}$ @ $T_C = 25^\circ\text{C}$	P_D	2.1 30	2.1 30	2.1 30	Watts
Operating and Storage Junction Temperature Range	T_J, T_{STG}	-55 to +150	-55 to +150	-55 to +150	$^\circ\text{C}$

thermal characteristics

Thermal Resistance, Junction to Ambient	$R_{\theta JA}$	60	60	60	$^\circ\text{C/W}$
Thermal Resistance, Junction to Case	$R_{\theta JC}$	4.2	4.2	4.2	$^\circ\text{C/W}$
Maximum Lead Temperature for Soldering Purposes: 1/8" from Case for 5 Seconds	T_L	260	260	260	$^\circ\text{C}$

electrical characteristics ($T_C = 25^\circ C$) (unless otherwise specified)

CHARACTERISTIC	SYMBOL	MIN	TYP	MAX	UNIT	
Collector-Emitter Breakdown Voltage ($I_C = 50mA$)	D44D1,2 D44D3,4 D44D5,6	$V_{CEO(BR)}$	40 60 80	— — —	— — —	Volts
Collector Cut-off Current ($V_{CE} = \text{Rated } V_{CES}$) ($V_{CE} = \text{Rated } V_{CES}, V_{BE} = 0.4V$)	$T_C = 25^\circ C$ $T_C = 125^\circ C$	I_{CES} I_{CEV}	— —	— —	10 5	μA
Emitter Cutoff Current ($V_{EB} = 5V$)		I_{EBO}	—	—	10	μA

second breakdown

Second Breakdown with Base Forward Biased	FBSOA	SEE FIGURE 5
---	-------	--------------

on characteristics

DC Current Gain ($I_C = 1A, V_{CE} = 2V$)	h_{FE}	2,000	5,000	—	—
Collector-Emitter Saturation Voltage ($I_C = 3A, I_B = 3mA$) ($I_C = 5A, I_B = 5mA$)	$V_{CE(sat)}$	— —	— —	1.5 1.5	V V
Base-Emitter Saturation Voltage ($I_C = 5A, I_B = 5mA$)	$V_{BE(sat)}$	—	—	2.5	Volts

dynamic characteristics

Collector Capacitance ($V_{CE} = 10V, f = 1MHz$)	C_{CBO}	—	—	45	pF
---	-----------	---	---	----	----

switching characteristics

Resistive Load	$I_C = 3A, I_{B1} = I_{B2} = 3mA$ $V_{CC} = 40V, t_p = 25 \mu sec$	$t_d + t_r$	—	0.5	—	μS
Delay Time + Rise Time						
Storage Time						
Fall Time						

(1) Pulse Test: $PW \leq 300ms$ Duty Cycle $\leq 2\%$.

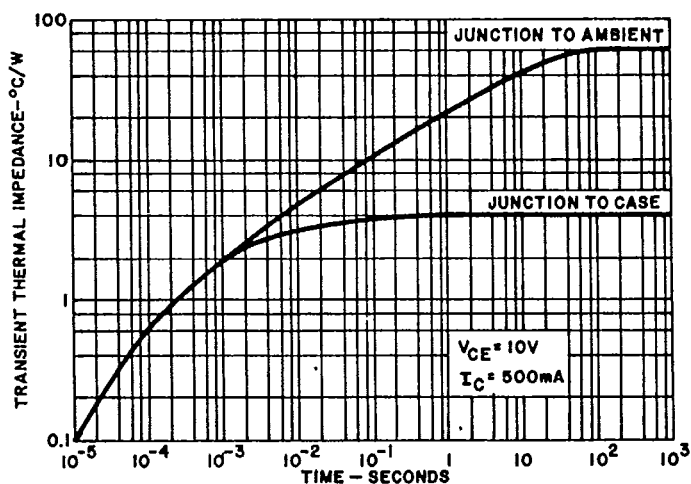

FIG. 1
MAXIMUM TRANSIENT THERMAL IMPEDANCE

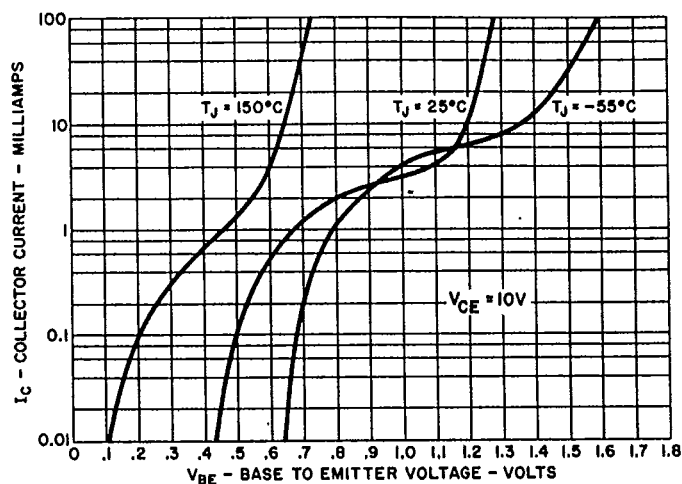

FIG. 2
TYPICAL TRANSCONDUCTANCE CHARACTERISTICS

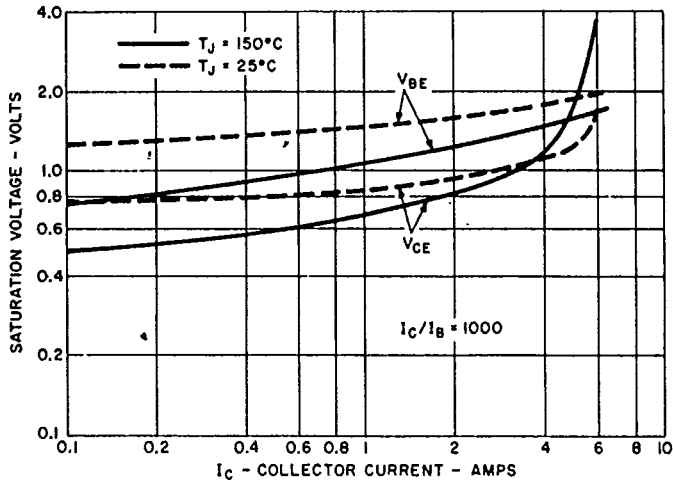

FIG. 3 TYPICAL SATURATION VOLTAGE CHARACTERISTICS

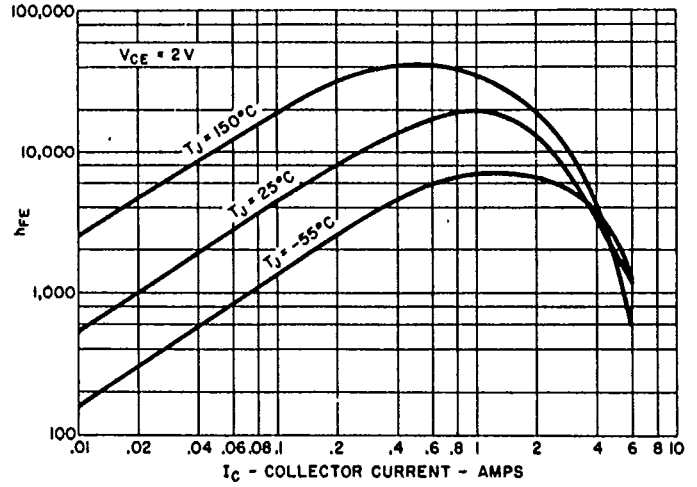

FIG. 4 TYPICAL h_{FE} VS. I_C

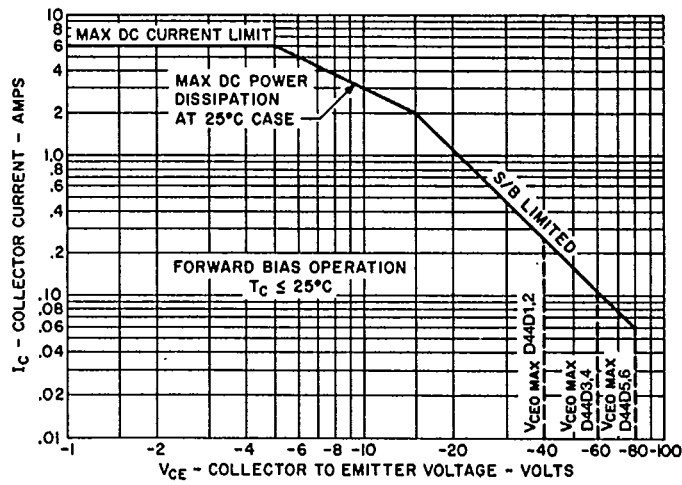

FIG. 5 SAFE REGION OF OPERATION