

# DIODE MODULE

## DD200GB



UL;E76102 (M)

Power Diode Module **DD200GB** series are designed for various rectifier circuits. **DD200GB** has two diode two diode chips connected in series and the mounting base is electrically isolated from elements for simple heatsink construction. Wide voltage rating up to 800V is available for various input voltages.

- Isolated mounting base
- Two elements in a package for simple (single and three phase) bridge connections
- Highly reliable glass passivated chips
- High surge current capability

### (Applications)

Various rectifiers, Battery chargers, DC motor drives

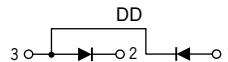
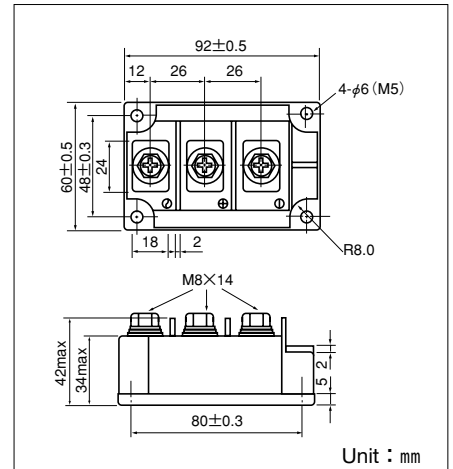

Unit : mm

### ■ Maximum Ratings

(T<sub>j</sub>=25°C unless otherwise specified)

Symbol	Item	Ratings		Unit
		DD200GB40	DD200GB80	
V <sub>RRM</sub>	Repetitive Peak Reverse Voltage	400	800	V
V <sub>RSM</sub>	Non-Repetitive Peak Reverse Voltage	480	960	V

Symbol	Item	Conditions	Ratings	Unit	
I <sub>F(AV)</sub>	Average Forward Current	Single phase, half wave, 180°C conduction, T <sub>c</sub> : 96°C	200	A	
I <sub>F(RMS)</sub>	R.M.S. Forward Current	Single phase, half wave, 180°C conduction, T <sub>c</sub> : 96°C	310	A	
I <sub>FSM</sub>	Surge Forward Current	1/2 cycle, 50/60Hz, peak value, non-repetitive	5000/5500	A	
I <sup>2</sup> t	I <sup>2</sup> t	Value for one cycle of surge current	125000	A <sup>2</sup> S	
T <sub>j</sub>	Operating Junction Temperature		-40 to +150	°C	
T <sub>stg</sub>	Storage Temperature		-40 to +125	°C	
V <sub>ISO</sub>	Isolation Breakdown Voltage (R.M.S.)	A.C. 1 minute	2500	V	
	Mounting Torque	Mounting (M5)	Recommended Value 1.5-2.5 (15-25)	2.7 (28)	N·m (kgf·cm)
		Terminal (M8)	Recommended Value 8.8-10 (90-105)	11 (115)	
	Mass	Typical Value	510	g	

### ■ Electrical Characteristics

(T<sub>j</sub>=25°C unless otherwise specified)

Symbol	Item	Conditions	Ratings	Unit
I <sub>RRM</sub>	Repetitive Peak Reverse Current, max.	at V <sub>RRM</sub> . Single phase, half wave, T <sub>j</sub> =150°C	50	mA
V <sub>FM</sub>	Forward Voltage Drop, max.	Forward current 600A, T <sub>j</sub> =25°C, Inst measurement	1.40	V
R <sub>th(j-c)</sub>	Thermal Impedance, max.	Junction to case (Per a half module)	0.18	°C/W

