

DIODE MODULE (F.R.D.)

DD250HB

TOP



UL;E76102 (M)

Power Diode Module **DD250HB** series are designed for various rectifier circuits. **DD250HB** has two diode chips connected in series in a package and the mounting base is electrically isolated from elements for simple heatsink construction. Wide voltage rating up to 1,600V is available for various input voltage.

- Isolated mounting base
- Two elements in a packing for simple (single and three phase) bridge connections
- Highly reliable glass passivated chips
- High surge current capability

(Applications)

Various rectifiers, Battery chargers, DC motor drives

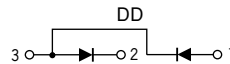
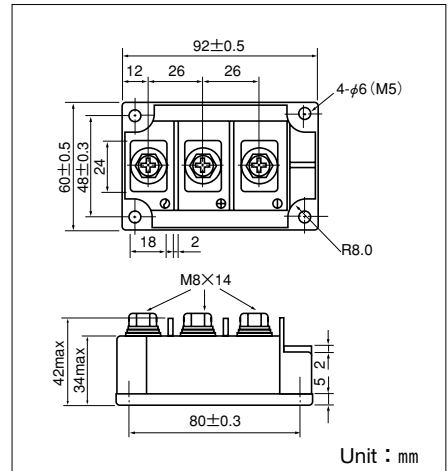

Maximum Ratings

(T_j=25°C unless otherwise specified)

Symbol	Item	Ratings		Unit
		DD250HB120	DD250HB160	
V _{RRM}	Repetitive Peak Reverse Voltage	1200	1600	V
V _{RSM}	Non-Repetitive Peak Reverse Voltage	1350	1700	V

Symbol	Item	Conditions	Ratings	Unit	
I _{F(AV)}	Average Forward Current	Single phase, half wave, 180°C conduction, T _c : 94°C	250	A	
I _{F(RMS)}	R.M.S. Forward Current	Single phase, half wave, 180°C conduction, T _c : 94°C	390	A	
I _{FSM}	Surge Forward Current	½ cycle, 50/60Hz, peak value, non-repetitive	5000/5500	A	
I ² t	I ² t	Value for one cycle of surge current	125000	A ² S	
T _j	Operating Junction Temperature		-40 to +150	°C	
T _{stg}	Storage Temperature		-40 to +125	°C	
V _{ISO}	Isolation Breakdown Voltage (R.M.S.)	A.C. 1 minute	2500	V	
	Mounting Torque	Mounting (M5)	Recommended Value 1.5-2.5 (15-25)	2.7 (28)	N·m (kgf·cm)
		Terminal (M8)	Recommended Value 8.8-10 (90-105)	11 (115)	
	Mass	Typical Value	510	g	

Electrical Characteristics

Symbol	Item	Conditions	Ratings			Unit
			Min.	Typ.	Max.	
I _{RRM}	Repetitive Peak Reverse Current	T _j =150°C at V _{RRM}			50	mA
V _{FM}	Forward Voltage Drop	T _j =25°C, I _{FM} =750A, Inst. measurement			1.45	V
R _{th(j-c)}	Thermal Impedance	Junction case			0.14	°C/W

