

# SHINDENGEN

## Schottky Rectifiers (SBD)

Dual

# DE10SC4

## 40V 10A

### FEATURES

- SMT
- $T_j 150^{\circ}\text{C}$
- $P_{RRSM}$  avalanche guaranteed
- High current capacity with Small Package

### APPLICATION

- Switching power supply
- DC/DC converter
- Home Appliances, Office Equipment
- Telecommunication

### OUTLINE DIMENSIONS

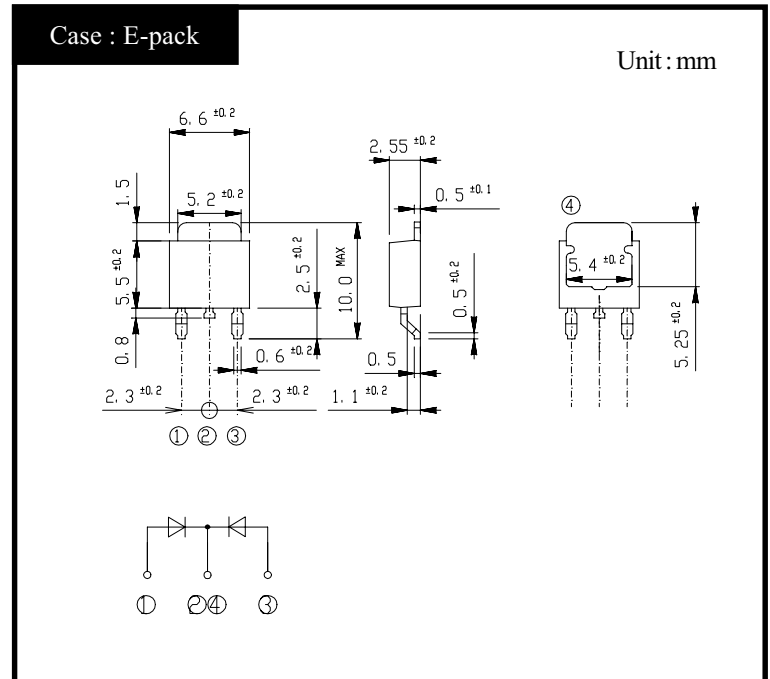

### RATINGS

#### ● Absolute Maximum Ratings (If not specified $T_c=25^{\circ}\text{C}$ )

Item	Symbol	Conditions	Ratings	Unit
Storage Temperature	$T_{stg}$		-55~150	$^{\circ}\text{C}$
Operating Junction Temperature	$T_j$		150	$^{\circ}\text{C}$
Maximum Reverse Voltage	$V_{RM}$		40	V
Repetitive Peak Surge Reverse Voltage	$V_{RRSM}$	Pulse width 0.5ms, duty 1/40	45	V
Average Rectified Forward Current	$I_O$	50Hz sine wave, R-load, Rating for each diode $I_o/2$ , $T_c=132^{\circ}\text{C}$	10	A
Peak Surge Forward Current	$I_{FSM}$	50Hz sine wave, Non-repetitive 1 cycle peak value, $T_j=25^{\circ}\text{C}$	100	A
Repetitive Peak Surge Reverse Power	$P_{RRSM}$	Pulse width 10 $\mu$ s, Rating of per diode, $T_j=25^{\circ}\text{C}$	330	W

#### ● Electrical Characteristics (If not specified $T_c=25^{\circ}\text{C}$ )

Item	Symbol	Conditions	Ratings	Unit
Forward Voltage	$V_F$	$I_F=5\text{A}$ , Pulse measurement, Rating of per diode	Max.0.55	V
Reverse Current	$I_R$	$V_R=V_{RM}$ , Pulse measurement, Rating of per diode	Max.3.5	mA
Junction Capacitance	$C_j$	$f=1\text{MHz}$ , $V_R=10\text{V}$ , Rating of per diode	Typ.210	pF
Thermal Resistance	$\theta_{jc}$	junction to case	Max.4	$^{\circ}\text{C/W}$

# DE10SC4

## Forward Voltage

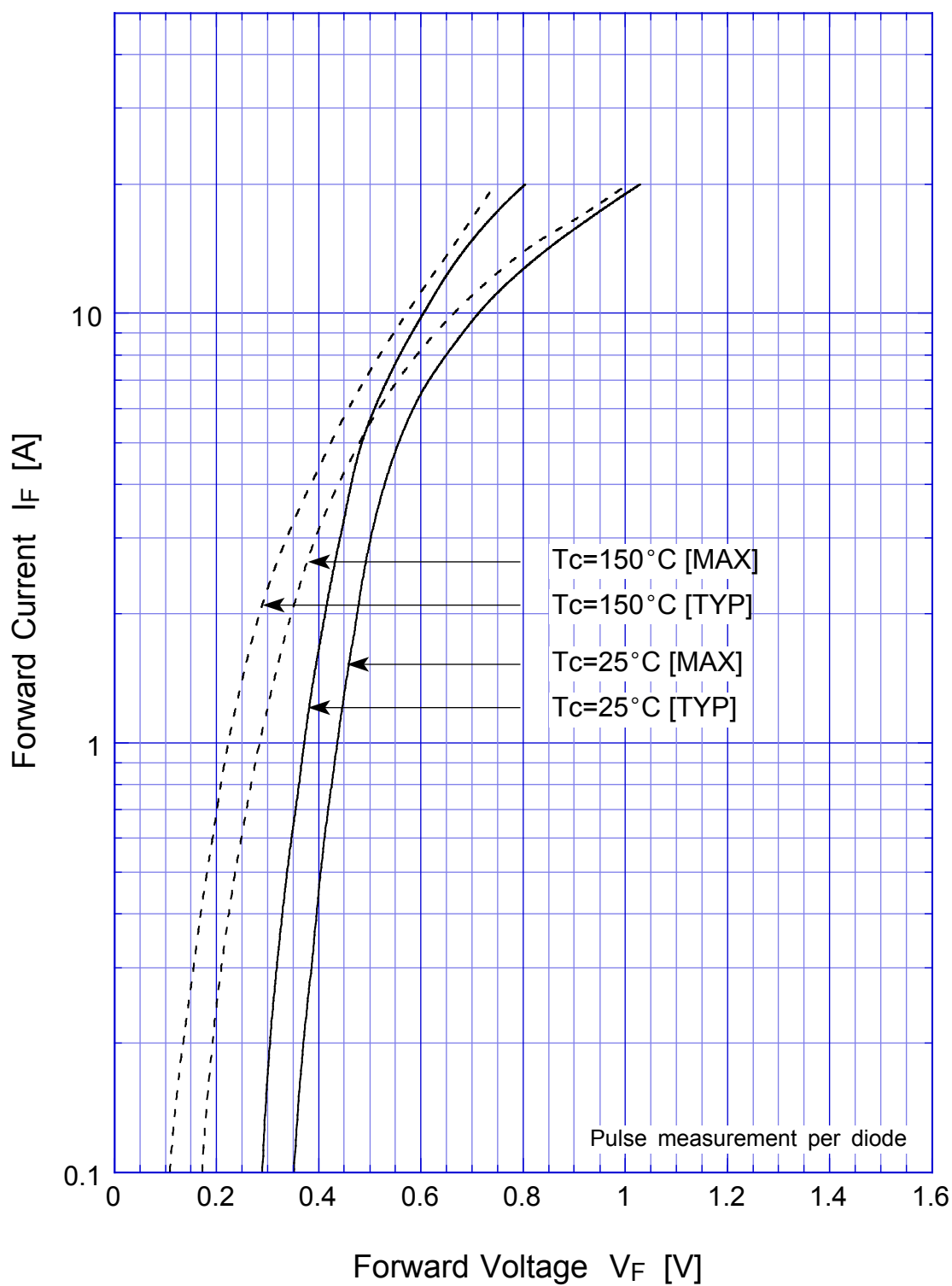

# DE10SC4 Junction Capacitance

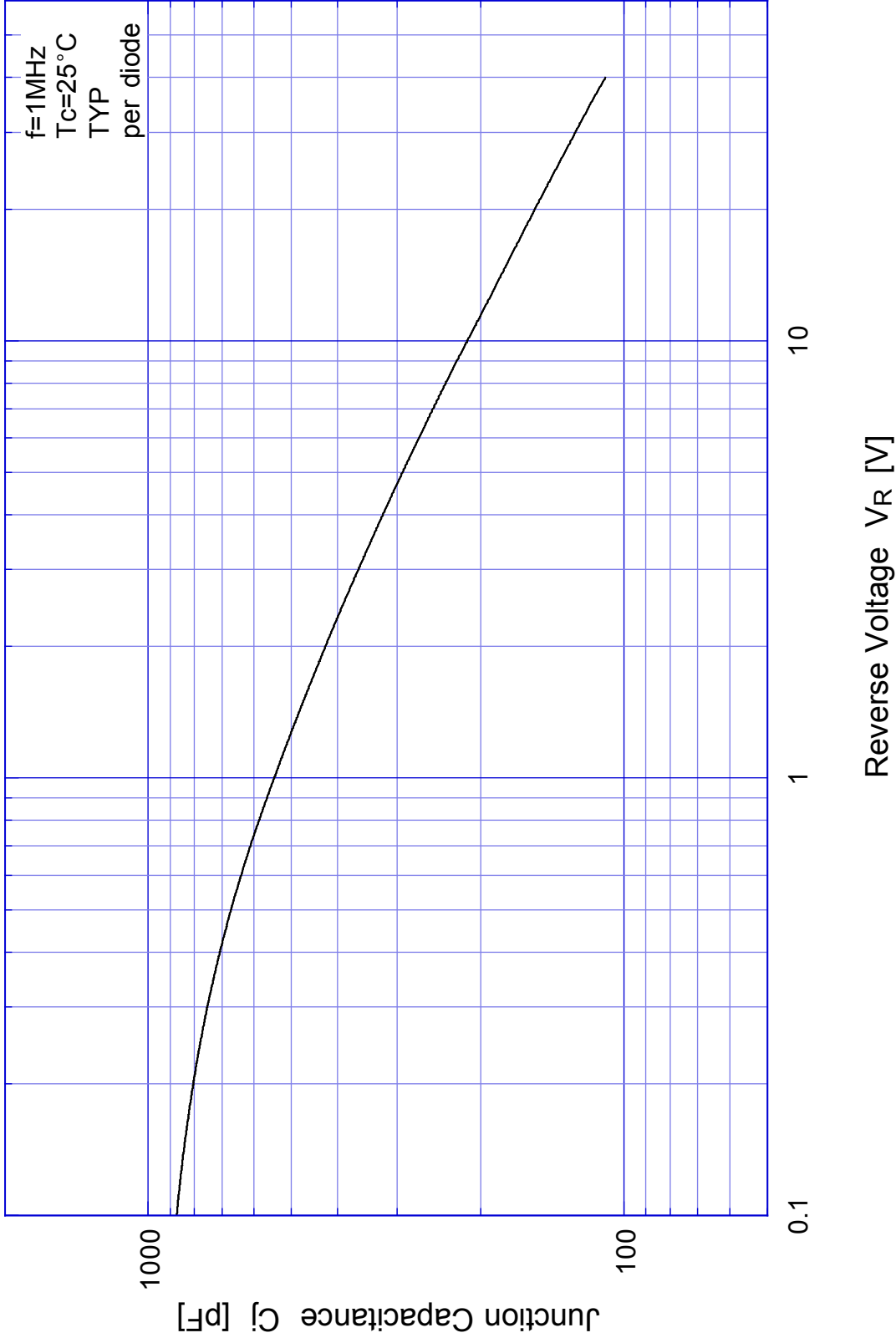

# DE10SC4

## Reverse Current

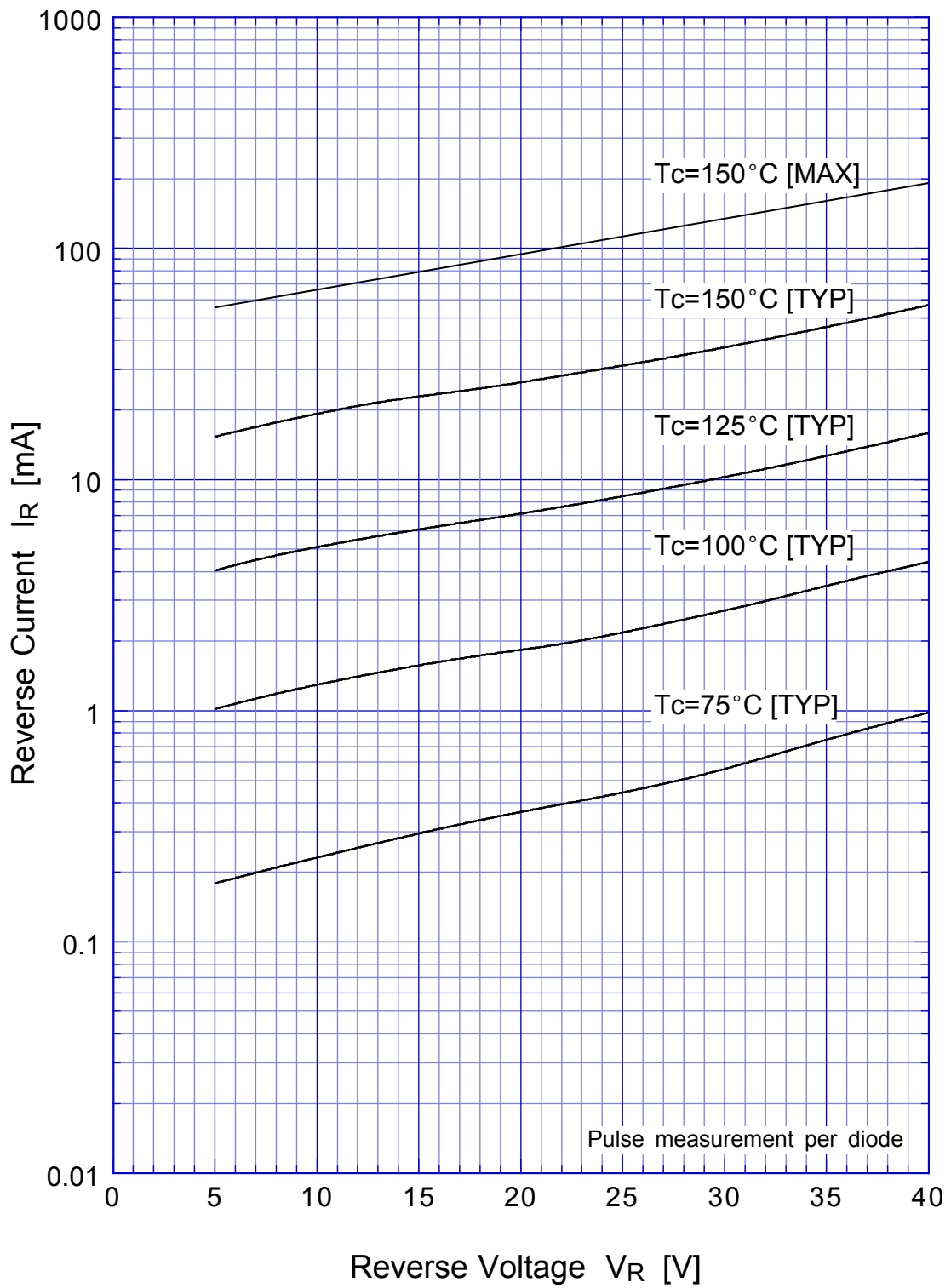

# DE10SC4 Reverse Power Dissipation

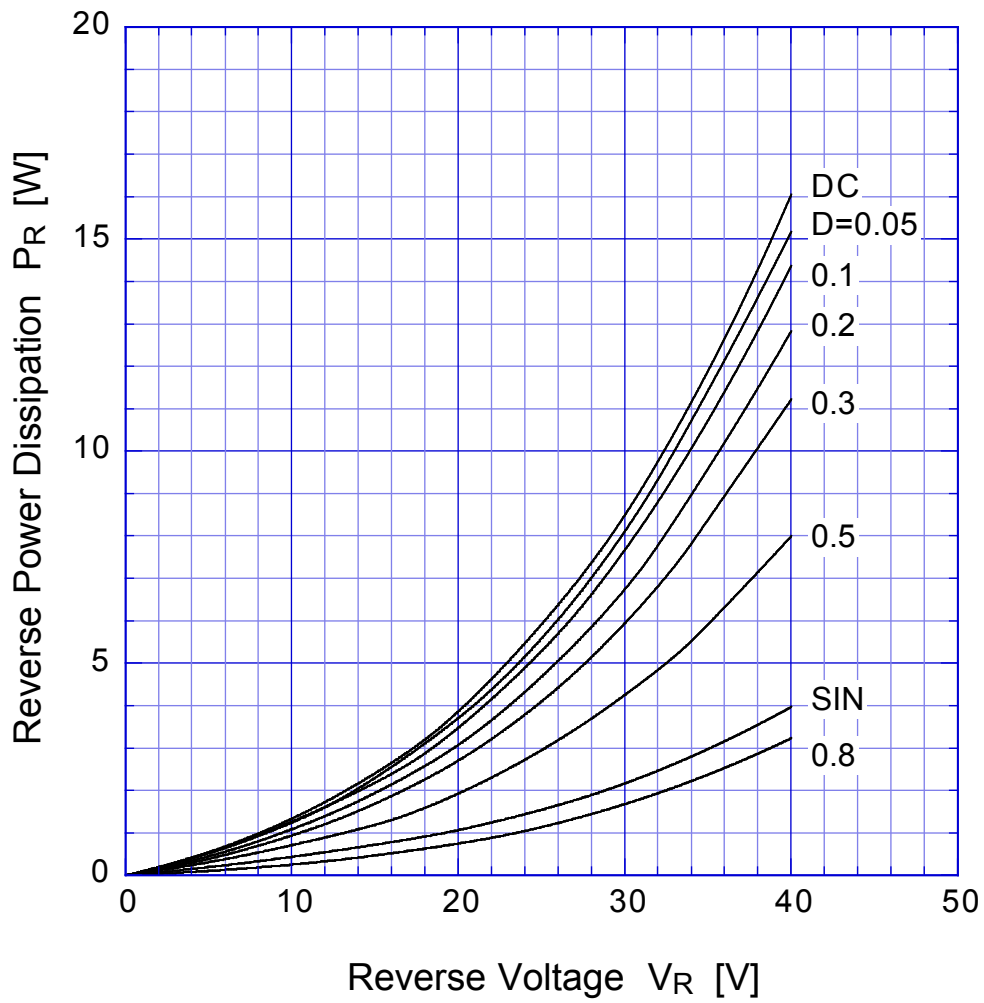

$T_j = 150^\circ\text{C}$

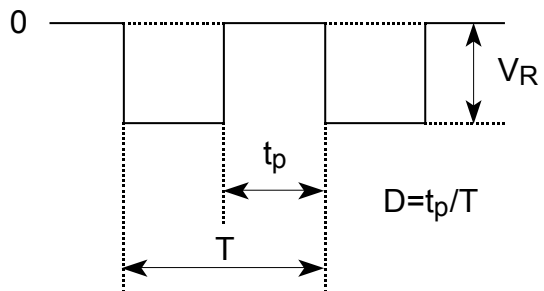

# DE10SC4 Forward Power Dissipation

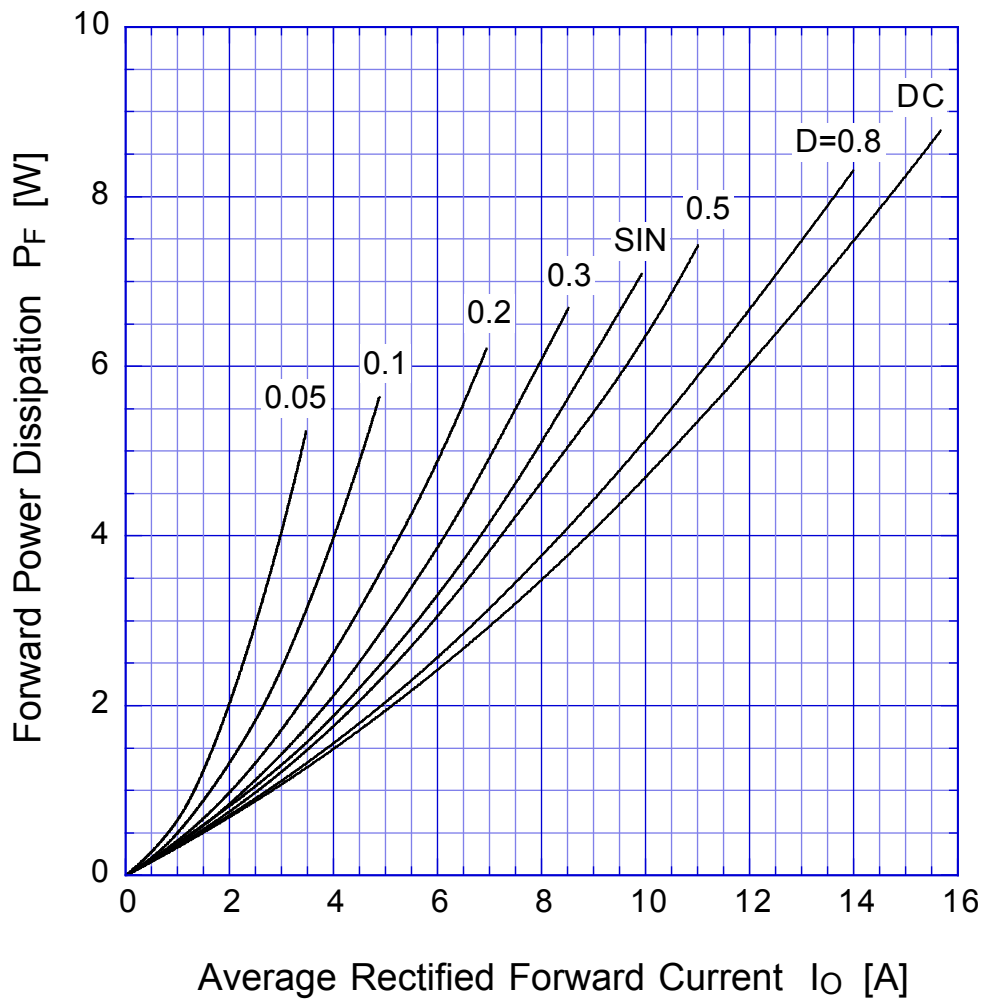

$T_j = 150^\circ\text{C}$

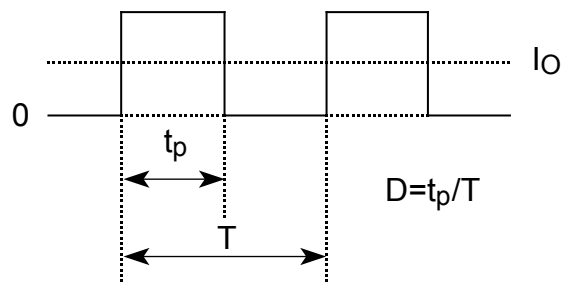

# DE10SC4

# Derating Curve

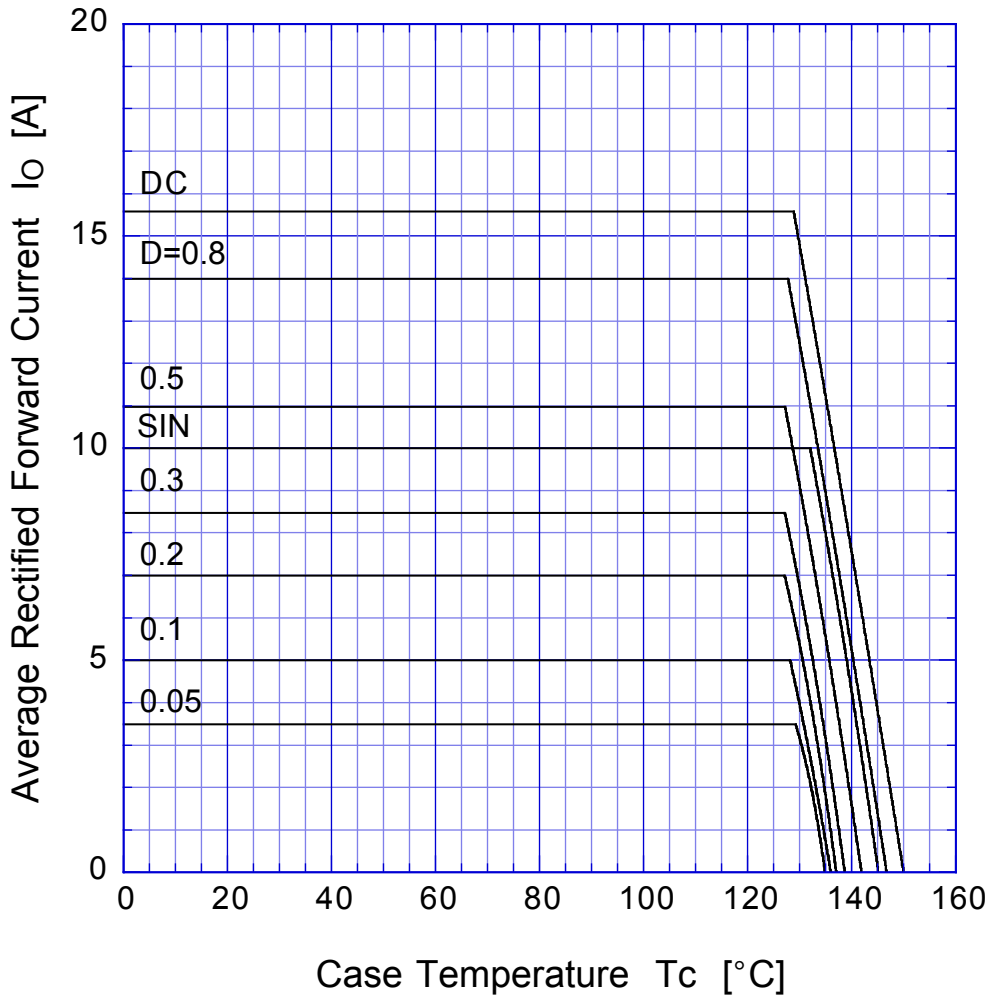

$V_R = 20V$

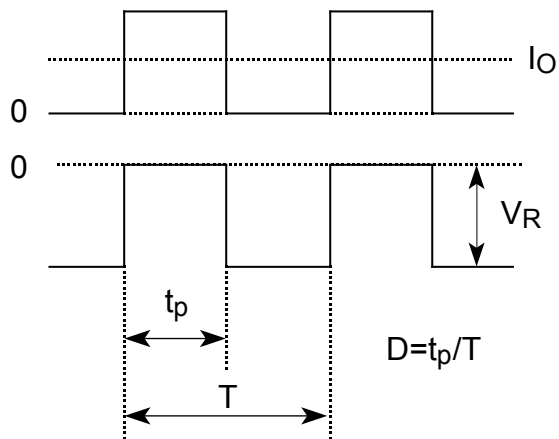

# DE10SC4 Peak Surge Forward Capability

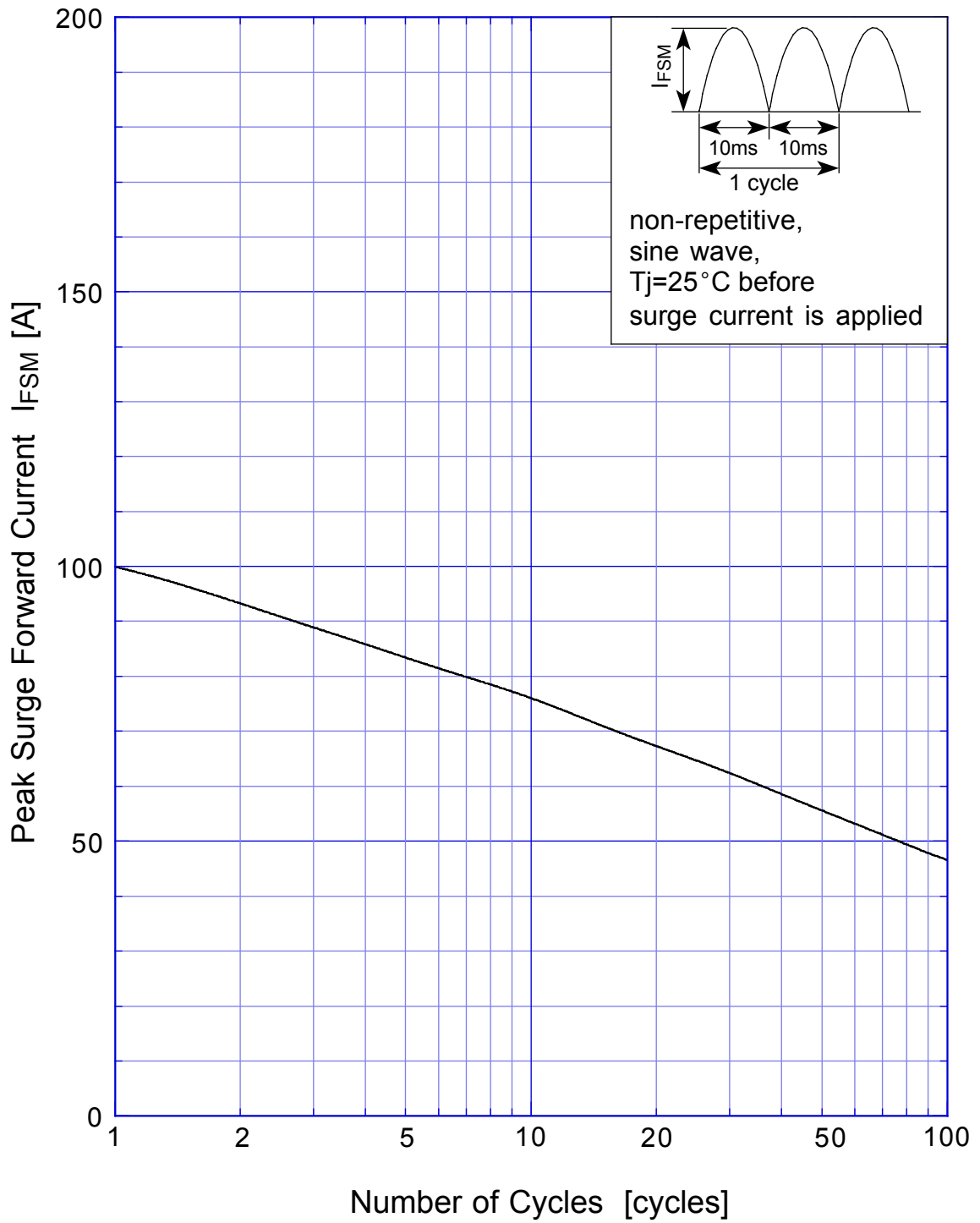

# SBD Repetitive Surge Reverse Power Derating Curve



# SBD

## Repetitive Surge Reverse Power Capability

