

# SHINDENGEN

## Schottky Rectifiers (SBD)

Single

# DE3S6M

## 60V 3A

### FEATURES

- SMT
- $T_j 150^{\circ}\text{C}$
- $P_{RRSM}$  avalanche guaranteed
- High current capacity with Small Package

### APPLICATION

- Switching power supply
- DC/DC converter
- Home Appliances, Office Equipment
- Telecommunication

### OUTLINE DIMENSIONS

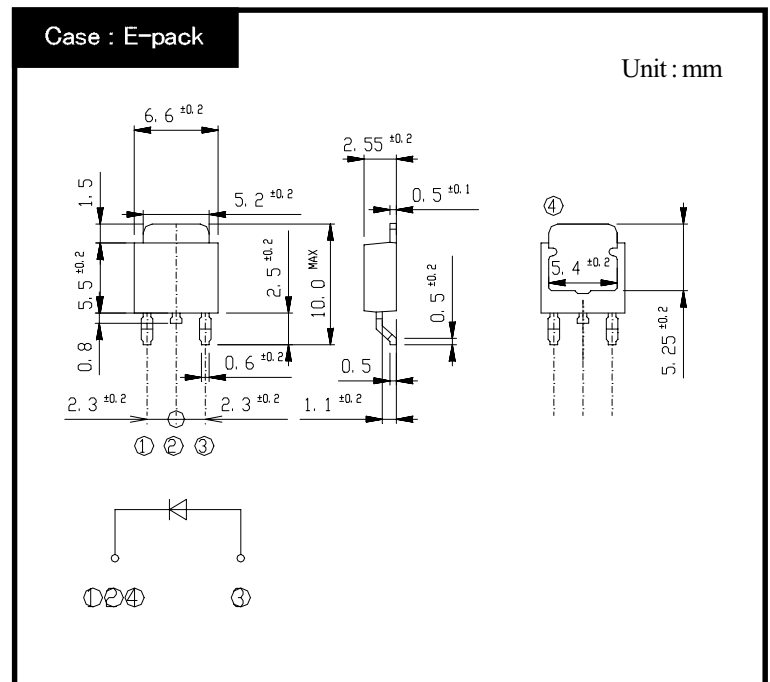

### RATINGS

- Absolute Maximum Ratings (If not specified  $T_c=25^{\circ}\text{C}$ )

Item	Symbol	Conditions	Ratings	Unit
Storage Temperature	$T_{stg}$		-40~150	$^{\circ}\text{C}$
Operating Junction Temperature	$T_j$		150	$^{\circ}\text{C}$
Maximum Reverse Voltage	$V_{RM}$		60	V
Repetitive Peak Surge Reverse Voltage	$V_{RRSM}$	Pulse width 0.5ms, duty 1/40	65	V
Average Rectified Forward Current	$I_o$	50Hz sine wave, R-load $T_a=31^{\circ}\text{C}$ On alumina substrate	2.5	A
		50Hz sine wave, R-load $T_c=117^{\circ}\text{C}$	3	
Peak Surge Forward Current	$I_{FSM}$	50Hz sine wave, Non-repetitive 1 cycle peak value, $T_j=125^{\circ}\text{C}$	80	A
Repetitive Peak Surge Reverse Power	$P_{RRSM}$	Pulse width 10 $\mu$ s, $T_j=25^{\circ}\text{C}$	330	W

- Electrical Characteristics (If not specified  $T_c=25^{\circ}\text{C}$ )

Item	Symbol	Conditions	Ratings	Unit
Forward Voltage	$V_F$	$I_F=3\text{A}$ , Pulse measurement	Max.0.58	V
Reverse Current	$I_R$	$V_R=V_{RM}$ , Pulse measurement	Max.2.5	mA
Junction Capacitance	$C_j$	$f=1\text{MHz}$ , $V_R=10\text{V}$	Typ.130	pF
Thermal Resistance	$\theta_{jc}$	junction to case	Max.12	$^{\circ}\text{C/W}$
	$\theta_{ja}$	junction to ambient	Max.55	

# DE3S6M

## Forward Voltage

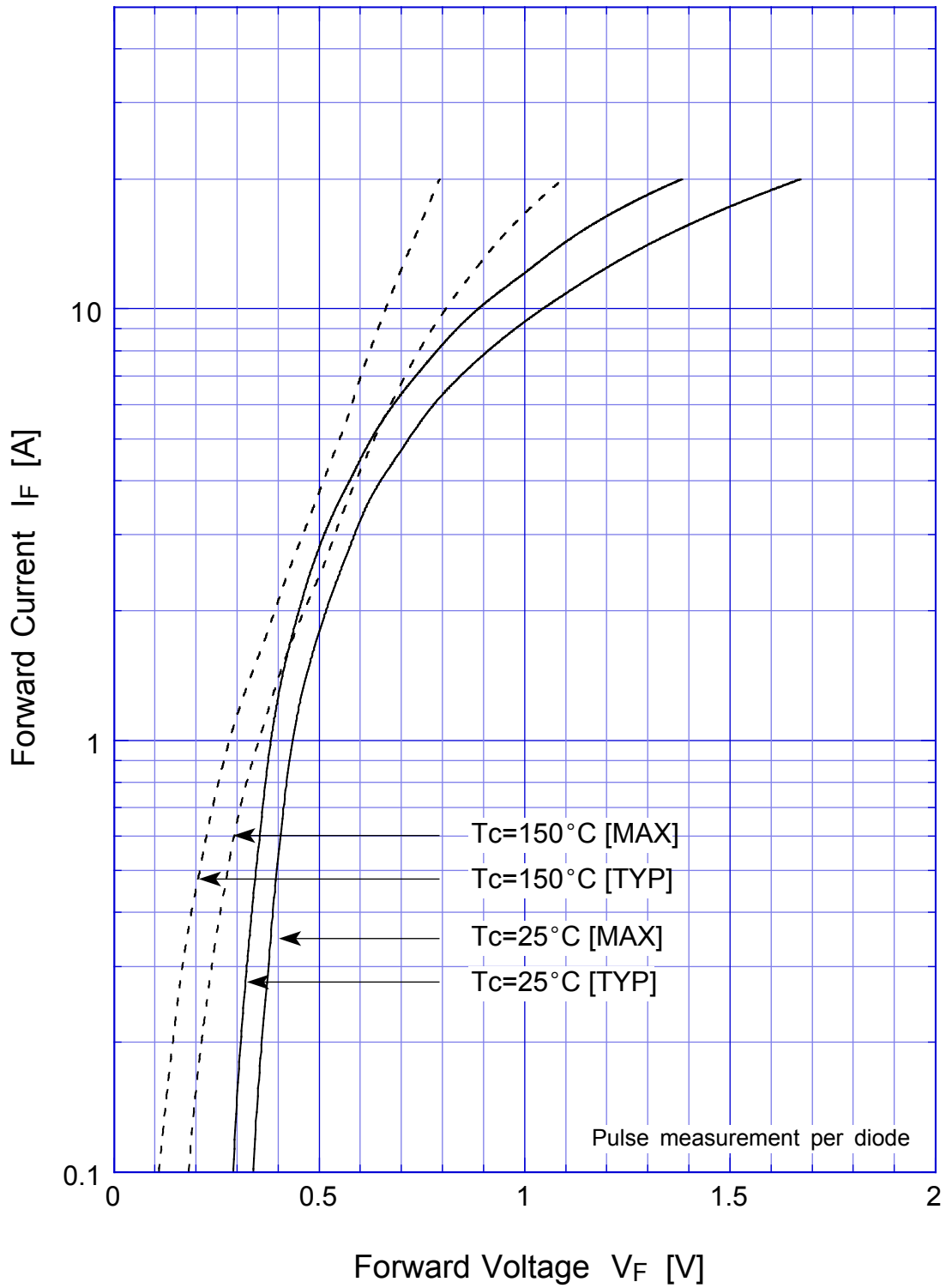

# DE3S6M

## Junction Capacitance

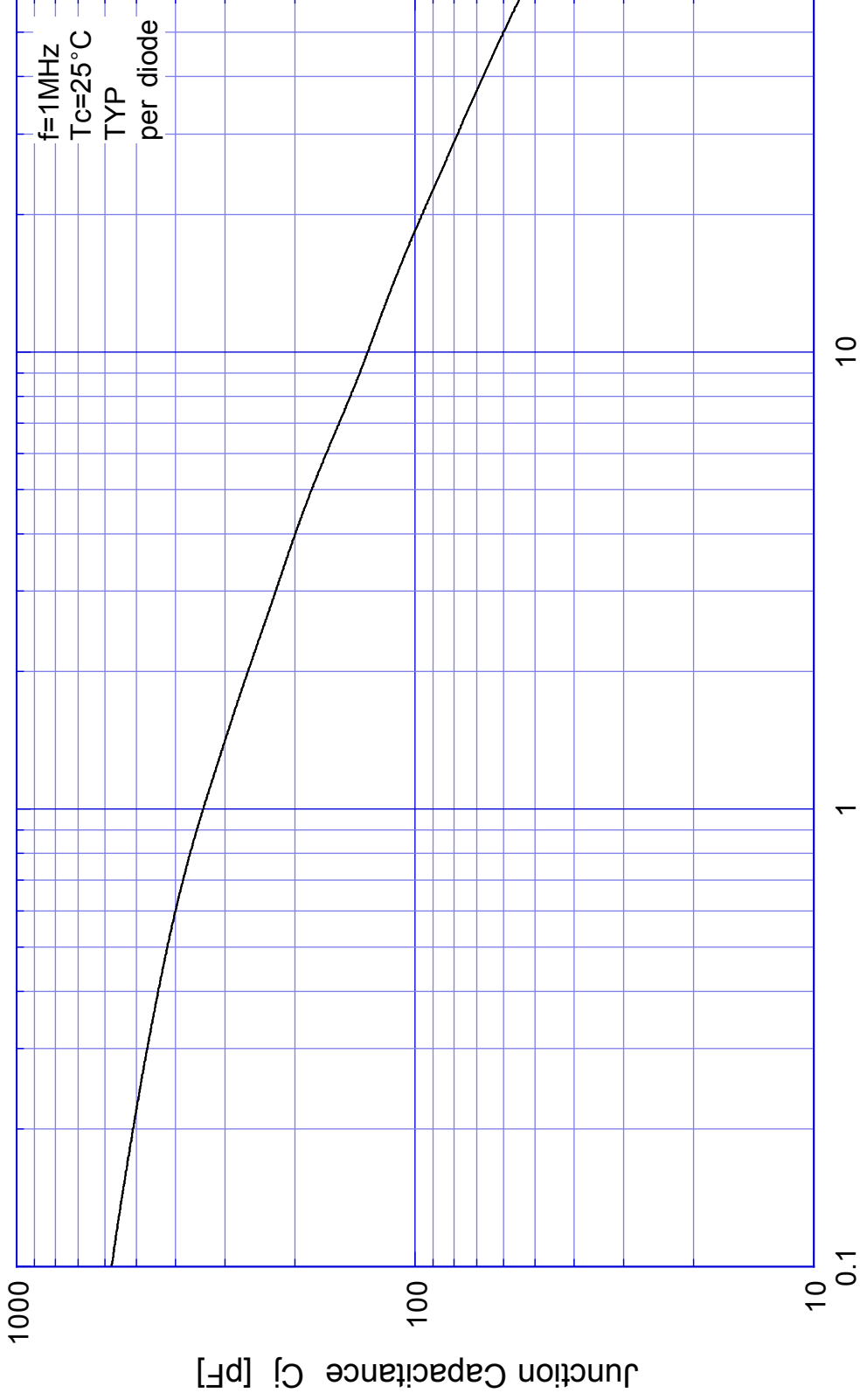

# DE3S6M

## Reverse Current

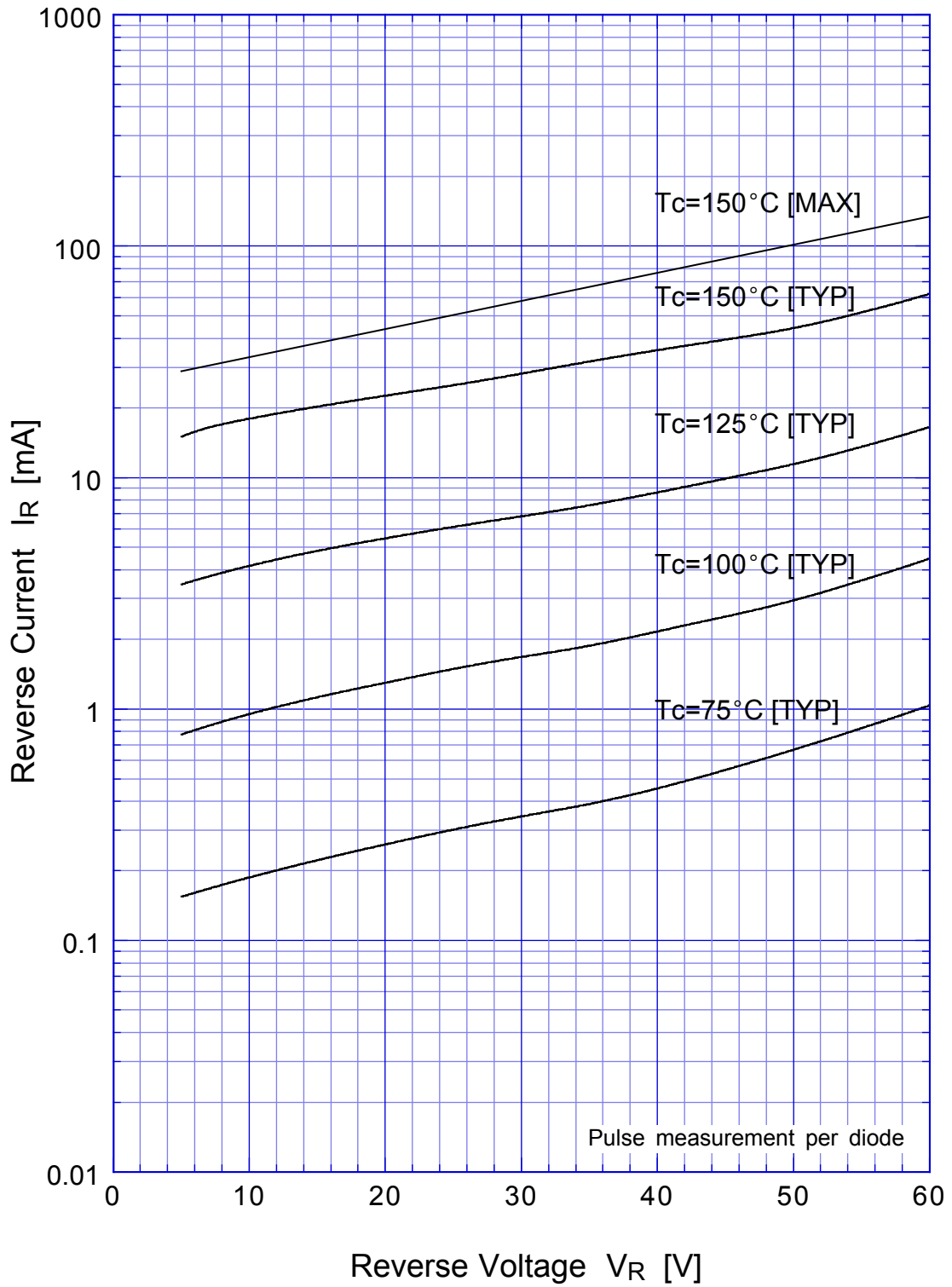

# DE3S6M Reverse Power Dissipation

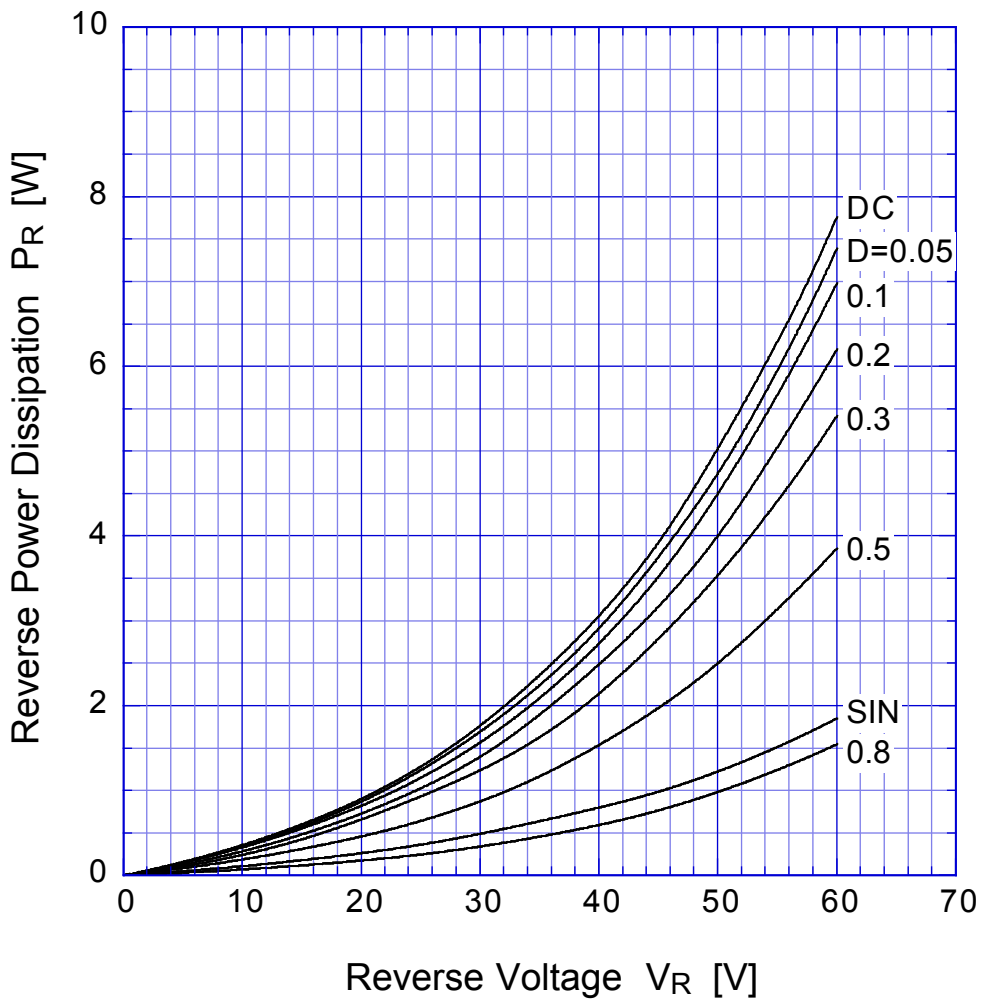

$T_j = 150^\circ\text{C}$

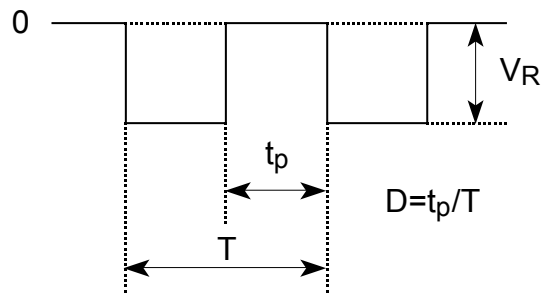

# DE3S6M Forward Power Dissipation

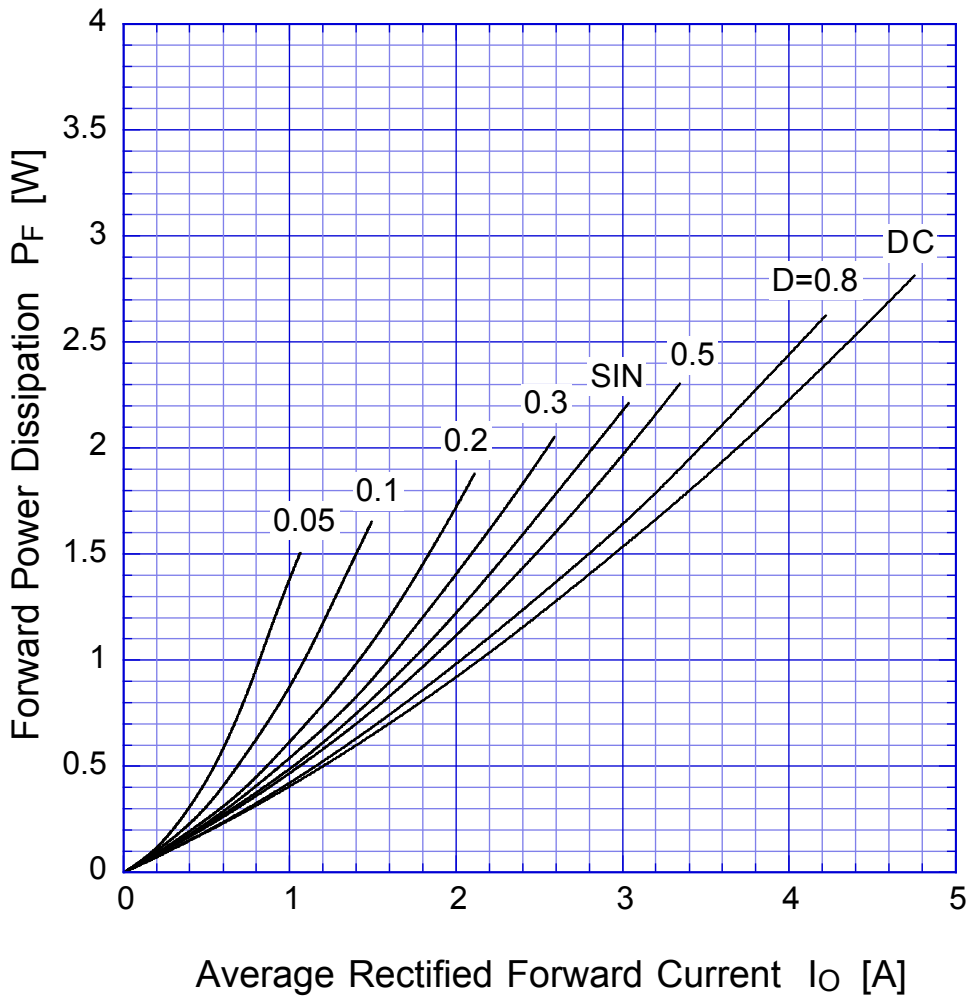

$T_j = 150^\circ\text{C}$

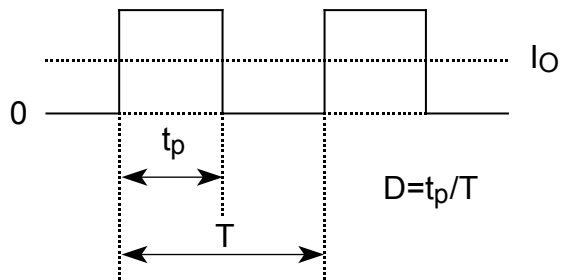

# DE3S6M

# Derating Curve

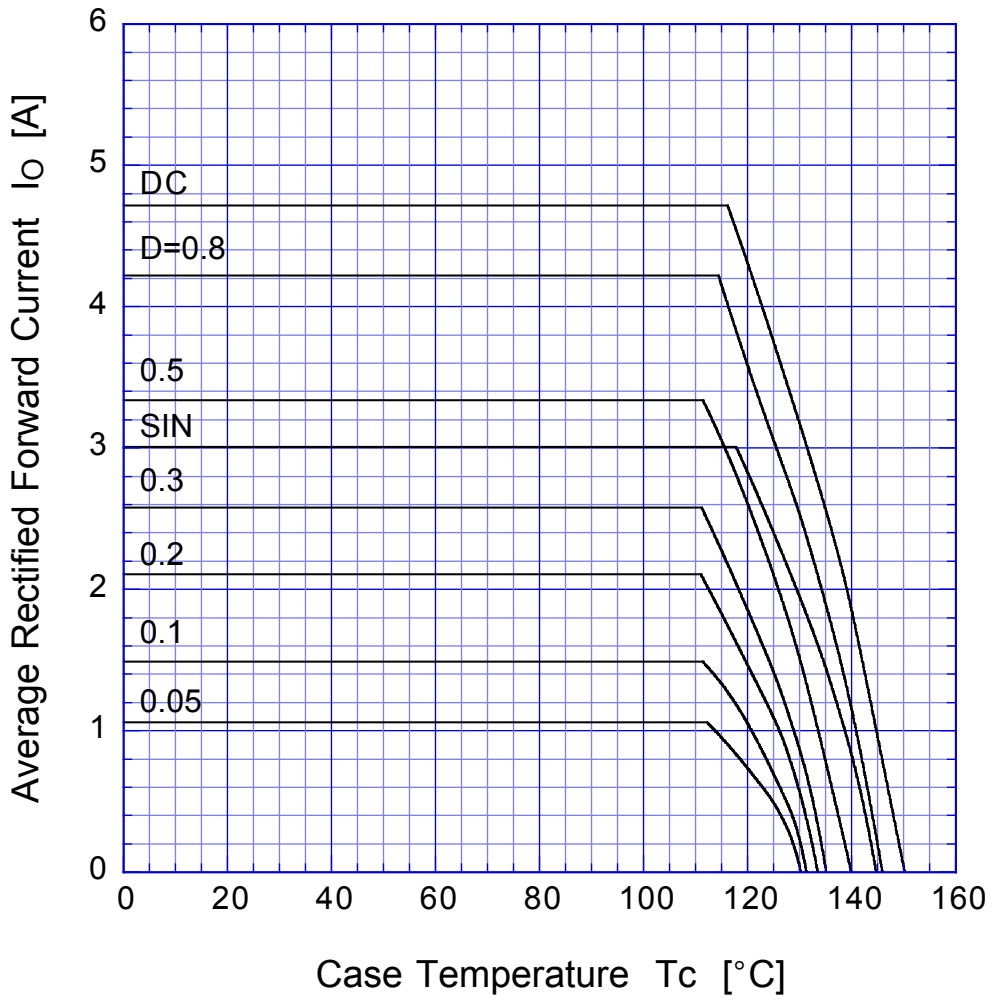

$V_R = 30V$



# DE3S6M

# Derating Curve

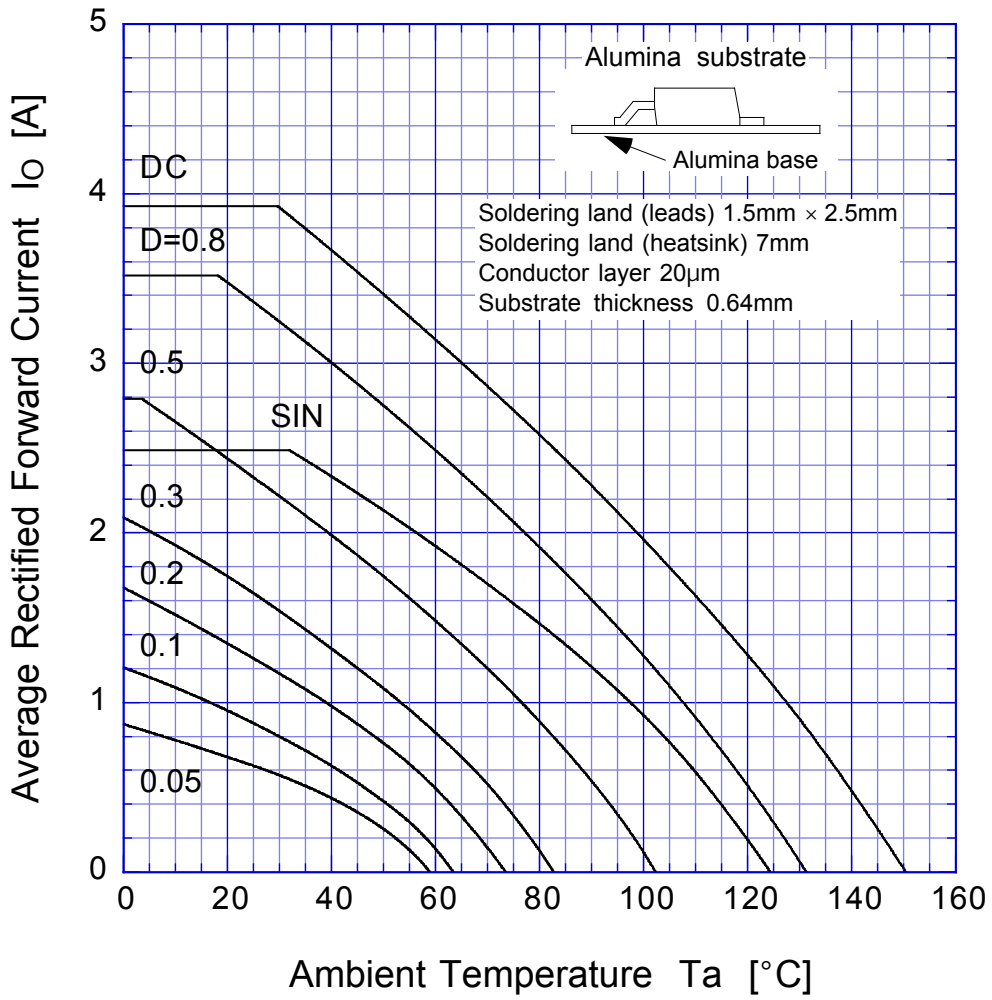

$V_R = 30V$

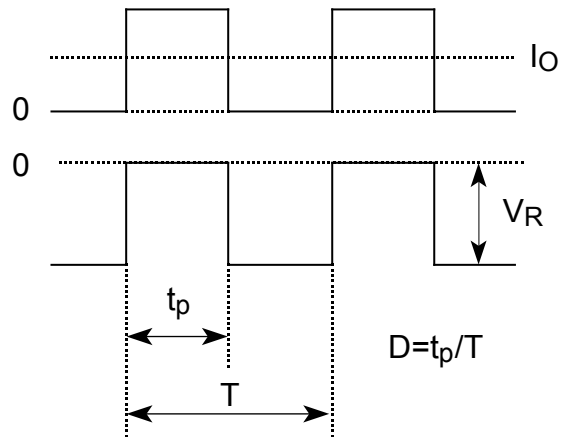

# DE3S6M

## Peak Surge Forward Capability

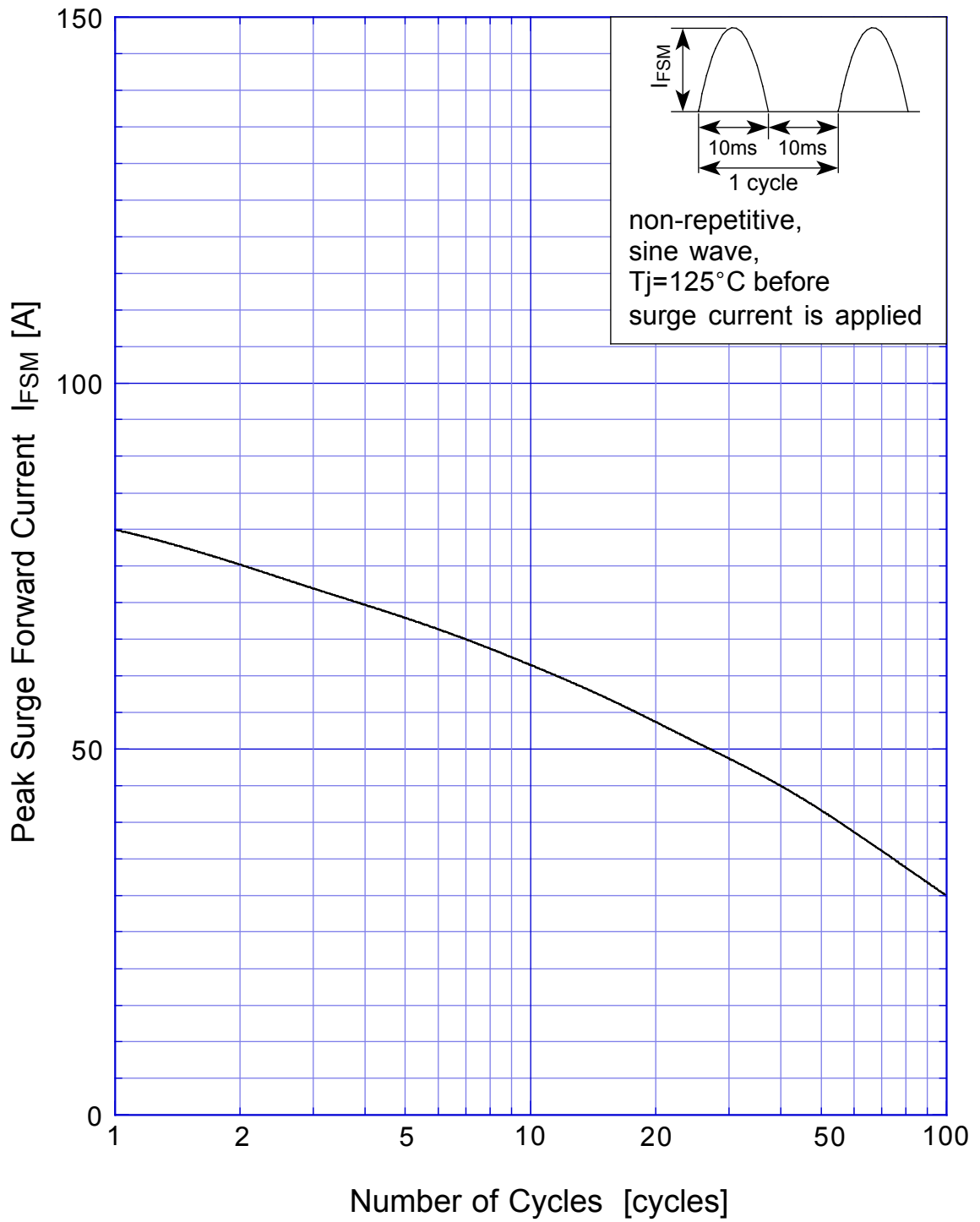

# SBD Repetitive Surge Reverse Power Derating Curve

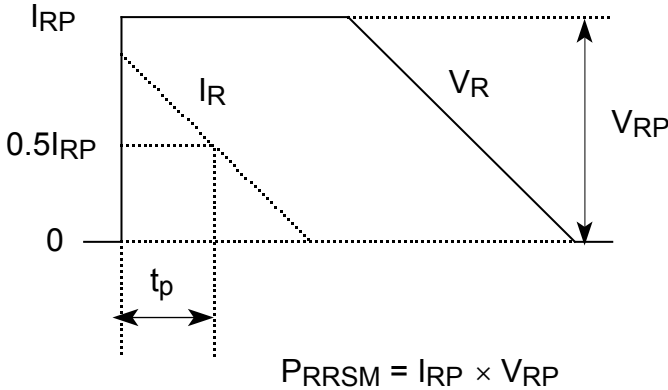

# SBD

## Repetitive Surge Reverse Power Capability

