

SHINDENGEN

Super Fast Recovery Rectifiers

Dual

DE5LC40

400V 5A

FEATURES

- SMT
- Low noise
- trr50ns

APPLICATION

- Switching power supply
- DC/DC converter
- Free Wheel
- Home Appliances, Office Equipment
- Telecommunication, Factory Automation

OUTLINE DIMENSIONS

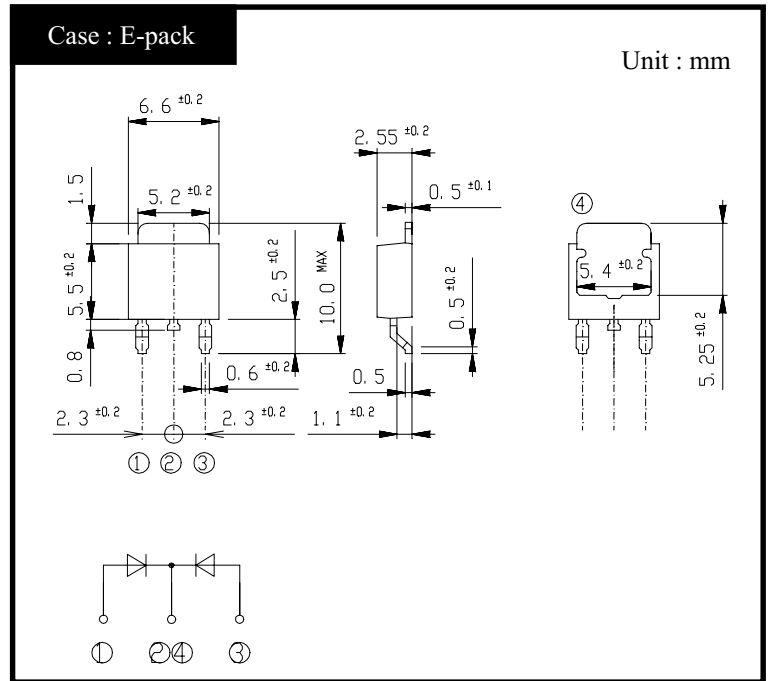

RATINGS

● Absolute Maximum Ratings (If not specified Tc=25°C)

Item	Symbol	Conditions	Ratings	Unit
Storage Temperature	T _{stg}		-55~150	°C
Operating Junction Temperature	T _j		150	°C
Maximum Reverse Voltage	V _{RM}		400	V
Average Rectified Forward Current	I _O	50Hz sine wave, R-load, Rating for each diode I _O /2, T _c =61°C	5	A
Peak Surge Forward Current	I _{FSM}	50Hz sine wave, Non-repetitive 1 cycle peak value, T _j =25°C	50	A

● Electrical Characteristics (If not specified Tc=25°C)

Item	Symbol	Conditions	Ratings	Unit
Forward Voltage	V _F	I _F =2.5A, Pulse measurement, Rating of per diode	Max.1.3	V
Reverse Current	I _R	V _R =V _{RM} , Pulse measurement, Rating of per diode	Max.10	μA
Reverse Recovery Time	trr	I _F =0.5A, I _R =1A, Rating of per diode	Max.50	ns
Thermal Resistance	θ _{jc}	junction to case	Max.12	°C/W
	θ _{ja}	junction to ambient	Max.55	°C/W

DE5LC40

Forward Voltage

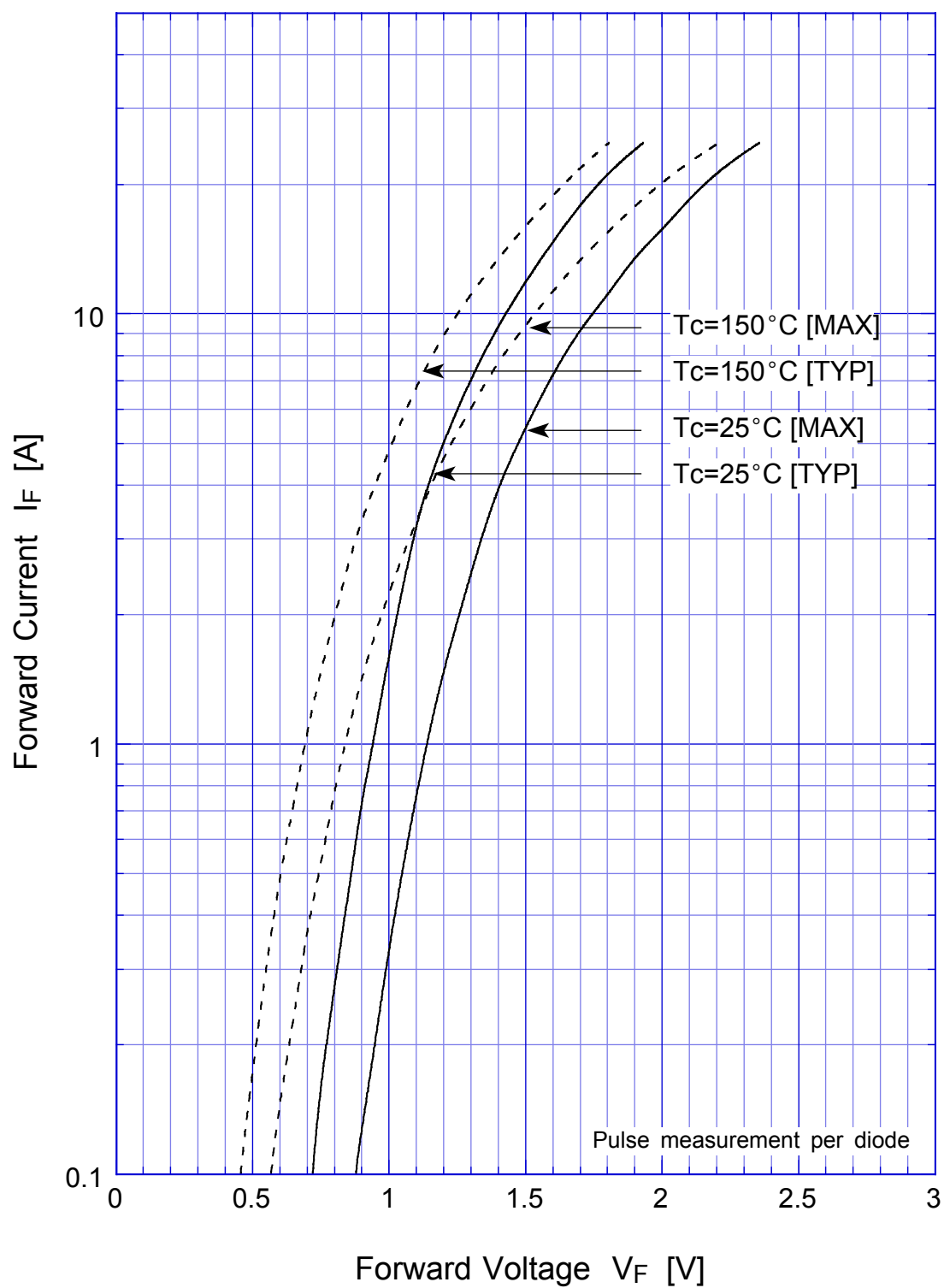

DE5LC40 Forward Power Dissipation

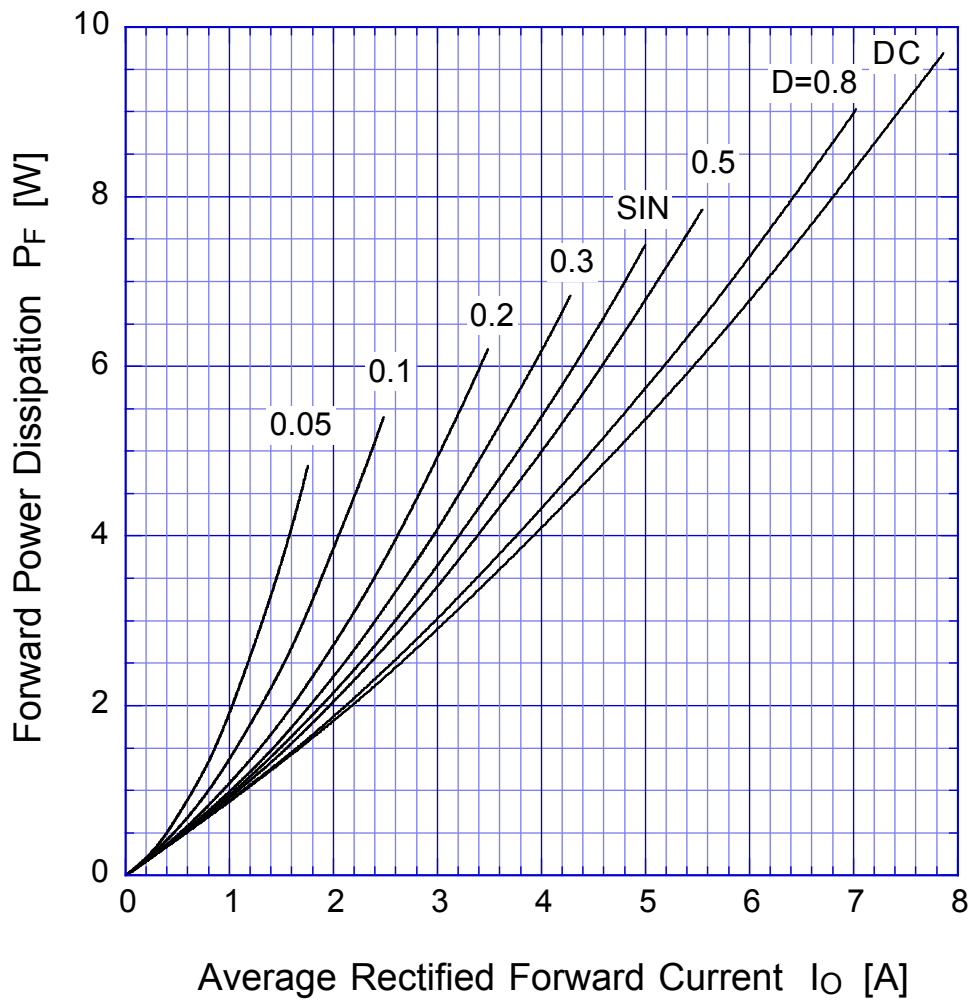

$T_j = 150^\circ\text{C}$

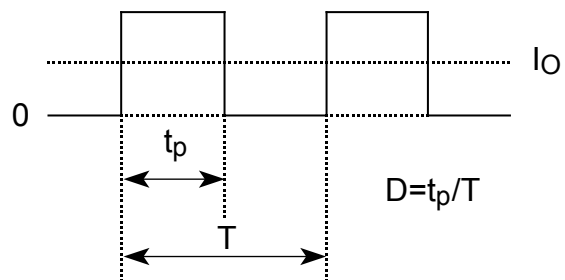

DE5LC40

Derating Curve

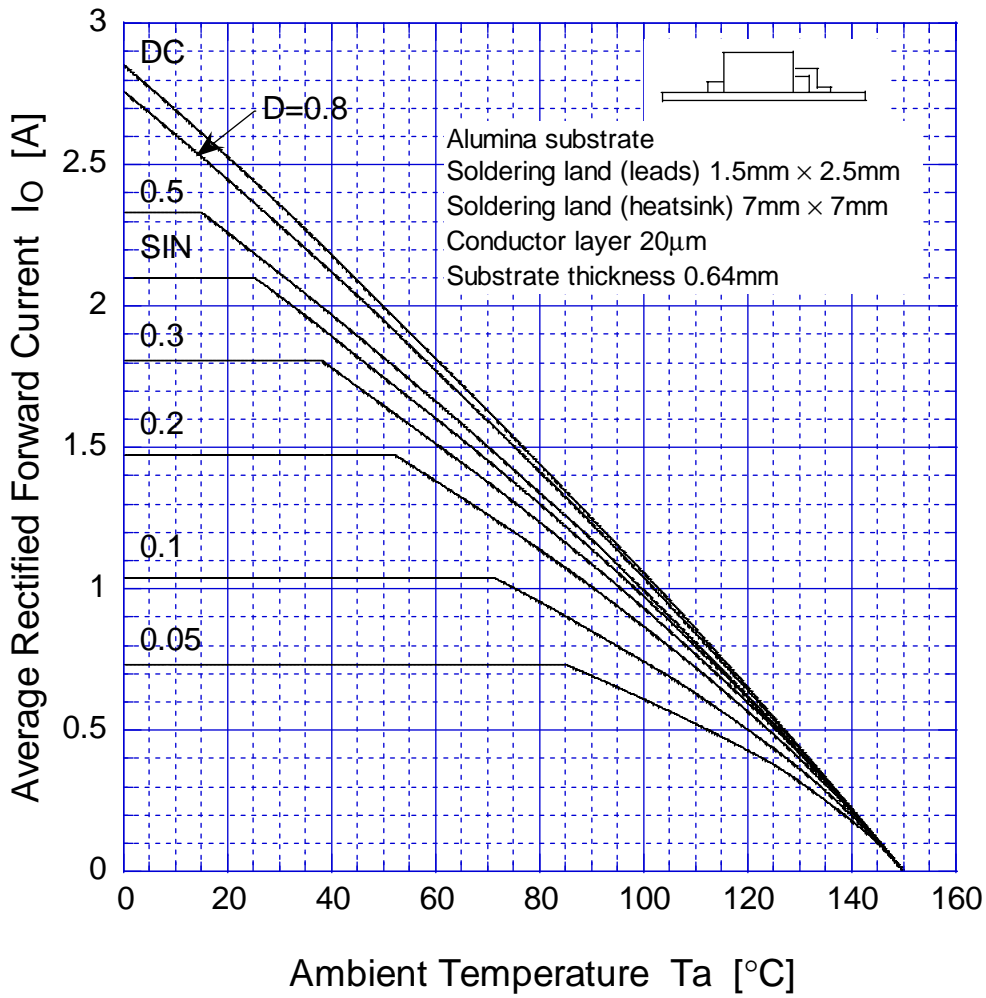

$$V_R = V_{RM}$$

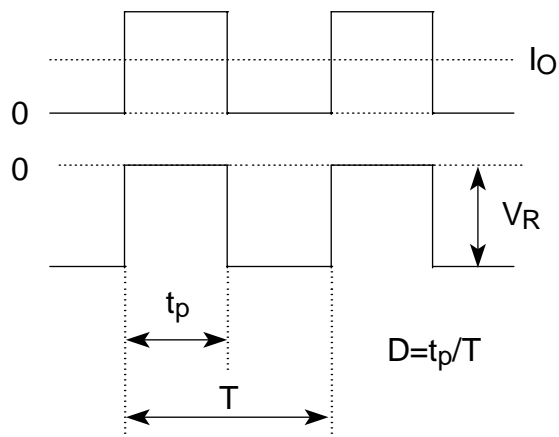

DE5LC40

Derating Curve

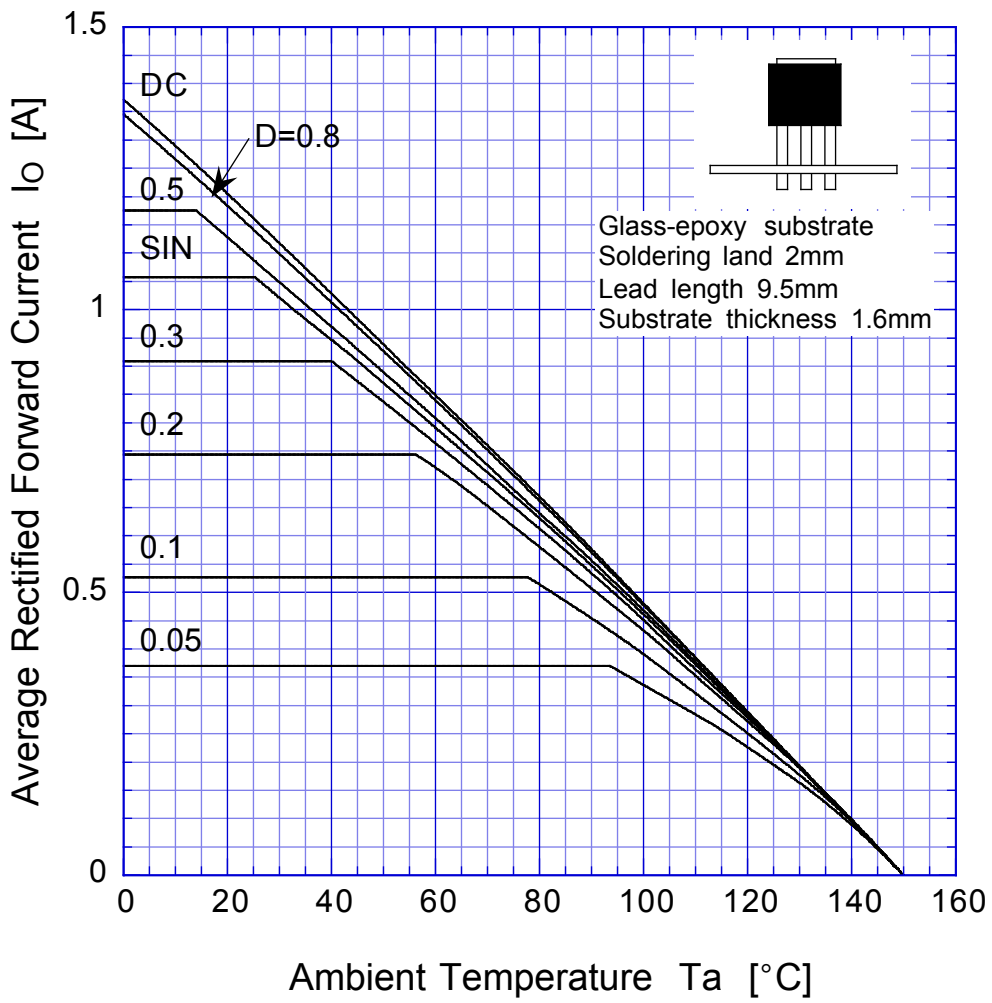

$$V_R = V_{RM}$$

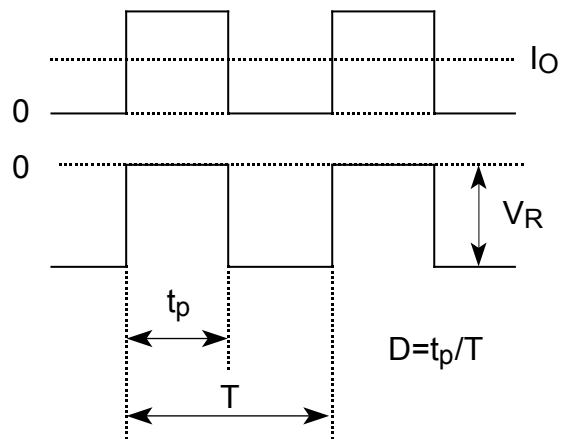

DE5LC40

Derating Curve

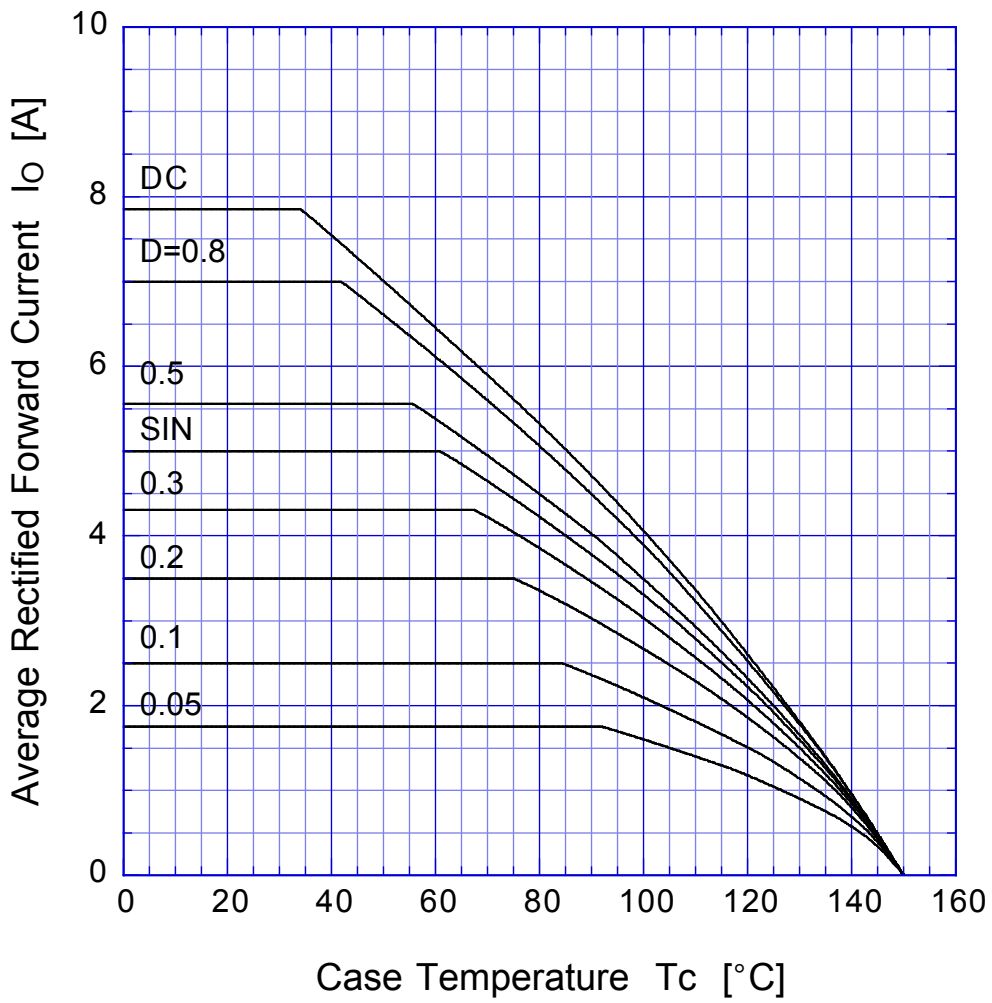

$$V_R = V_{RM}$$

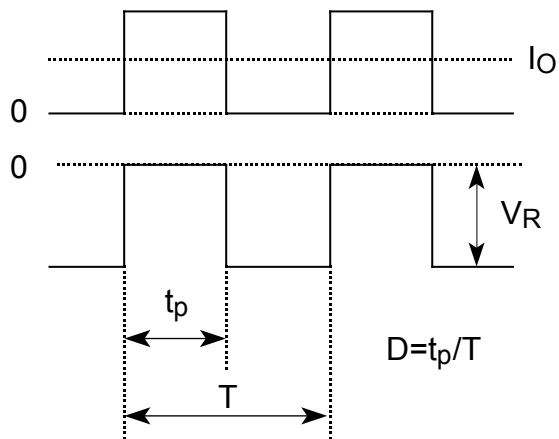

DE5LC40

Peak Surge Forward Capability

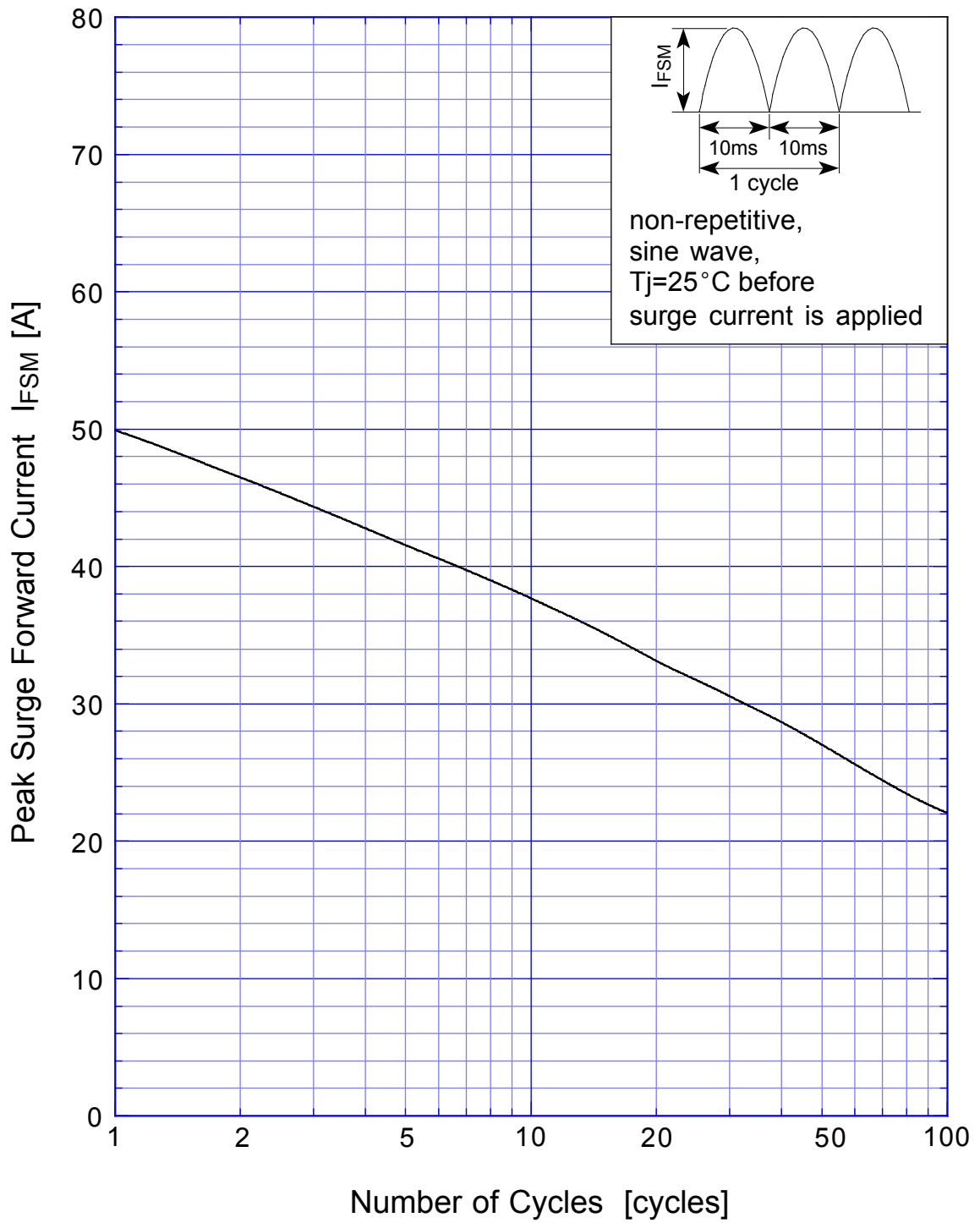

DE5LC40 Junction Capacitance

