

## DM74ALS1005 Hex Inverting Driver with Open Collector Outputs

### General Description

These devices contain six independent drivers, each of which performs the logic INVERT/Complement function. The outputs require external pull-up resistors for proper logical operation. The 'ALS1005 is a driver version of the 'ALS05A.

#### Pull-Up Resistor Equations

$$R_{MAX} = \frac{V_{CC} (Min) - V_{OH}}{N_1 (I_{OH}) + N_2 (I_{IH})}$$

$$R_{MIN} = \frac{V_{CC} (Max) - V_{OL}}{I_{OL} - N_3 (I_{IL})}$$

Where:  $N_1 (I_{OH})$  = total maximum output high current for all outputs tied to pull-up resistor

$N_2 (I_{IH})$  = total maximum input high current for all inputs tied to pull-up resistor

$N_3 (I_{IL})$  = total maximum input low current for all inputs tied to pull-up resistor

### Features

- Switching specifications at 50 pF
- Switching specifications guaranteed over full temperature and  $V_{CC}$  range
- Advanced oxide-isolated, ion-implanted Schottky TTL process
- Functionally and pin for pin compatible with Schottky and low power Schottky TTL counterpart
- Improved AC performance over Schottky and low power Schottky counterparts

### Connection Diagram

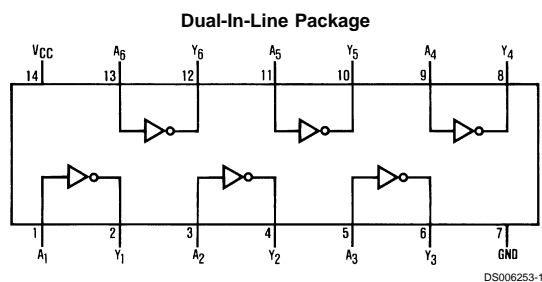

Order Number DM74ALS1005M, N  
See Package Number M14A or N14A

### Function Table

$$Y = \overline{A}$$

Input A	Output Y
H	L
L	H

L = Low Logic Level  
H = High Logic Level

**Absolute Maximum Ratings** (Note 1)

Supply Voltage	7V	DM74ALS	0°C to +70°C
Input Voltage	7V	Storage Temperature Range	-65°C to +150°C
Off-State Output Voltage	7V	Typical $\theta_{JA}$	
Operating Free Air Temperature Range		N Package	76.0°C/W
		M Package	106.5°C/W

**Recommended Operating Conditions**

Symbol	Parameter	DM74ALS1005			Units
		Min	Nom	Max	
$V_{CC}$	Supply Voltage	4.5	5	5.5	V
$V_{IH}$	High Level Input Voltage	2			V
$V_{IL}$	Low Level Input Voltage			0.8	V
$V_{OH}$	High Level Output Voltage			5.5	V
$I_{OL}$	Low Level Output Current			24	mA
$T_A$	Free Air Operating Temperature	0		70	°C

**Note 1:** The "Absolute Maximum Ratings" are those values beyond which the safety of the device cannot be guaranteed. The device should not be operated at these limits. The parametric values defined in the "Electrical Characteristics" table are not guaranteed at the absolute maximum ratings. The "Recommended Operating Conditions" table will define the conditions for actual device operation.

**Electrical Characteristics**

over recommended operating free air temperature range. All typical values are measured at  $V_{CC} = 5V$ ,  $T_A = 25^\circ C$ .

Symbol	Parameter	Conditions	Min	Typ	Max	Units
$V_{IK}$	Input Clamp Voltage	$V_{CC} = 4.5V$ , $I_I = -18\text{ mA}$			-1.5	V
$I_{OH}$	High Level Output Current	$V_{CC} = 4.5V$ , $V_{OH} = 5.5V$			100	$\mu A$
$V_{OL}$	Low Level Output Voltage	$V_{CC} = 4.5V$	$I_{OL} = 12\text{ mA}$	0.25	0.4	V
			$I_{OL} = 24\text{ mA}$	0.35	0.5	V
$I_I$	Input Current at Max Input Voltage	$V_{CC} = 5.5V$ , $V_{IH} = 7V$			0.1	mA
$I_{IH}$	High Level Input Current	$V_{CC} = 5.5V$ , $V_{IH} = 2.7V$			20	$\mu A$
$I_{IL}$	Low Level Input Current	$V_{CC} = 5.5V$ , $V_{IL} = 0.4V$			-0.1	mA
$I_{CC}$	Supply Current	$V_{CC} = 5.5V$	Outputs High	0.9	3	mA
			Outputs Low	7	12	mA

**Switching Characteristics**

over recommended operating free air temperature range (Note 2)

Symbol	Parameter	Conditions	DM74ALS1005		Units
			Min	Max	
$t_{PLH}$	Propagation Delay Time Low to High Level Output	$V_{CC} = 4.5V$ to $5.5V$ $R_L = 680\Omega$	5	30	ns
$t_{PHL}$	Propagation Delay Time High to Low Level Output	$C_L = 50\text{ pF}$	2	10	ns

**Note 2:** See Section 1 for test waveforms and output load.

**Physical Dimensions** inches (millimeters) unless otherwise noted

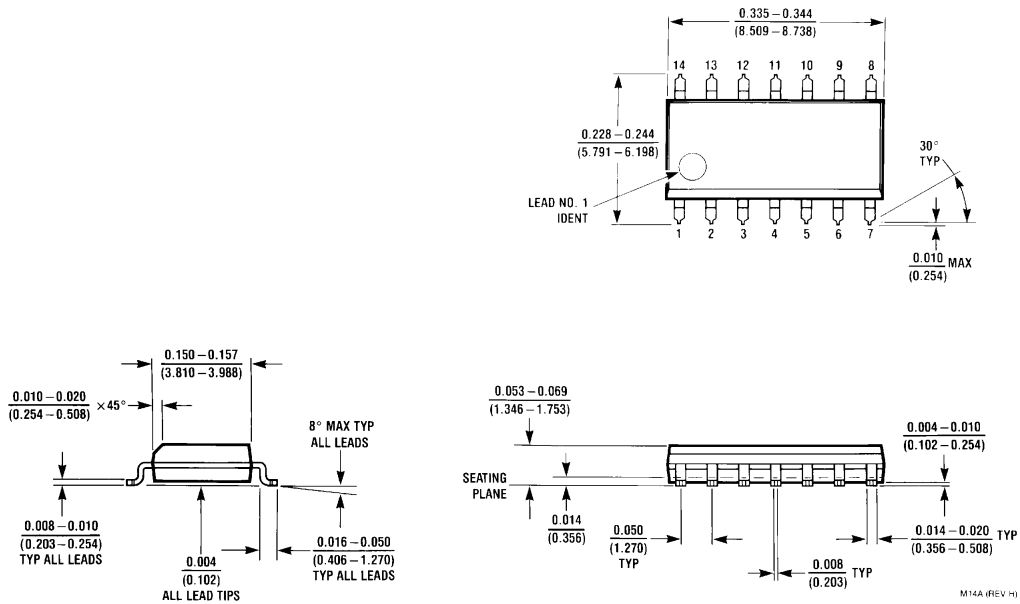

**S.O. Package (M)**  
**Order Number DM74ALS1005M**  
**Package Number M14A**

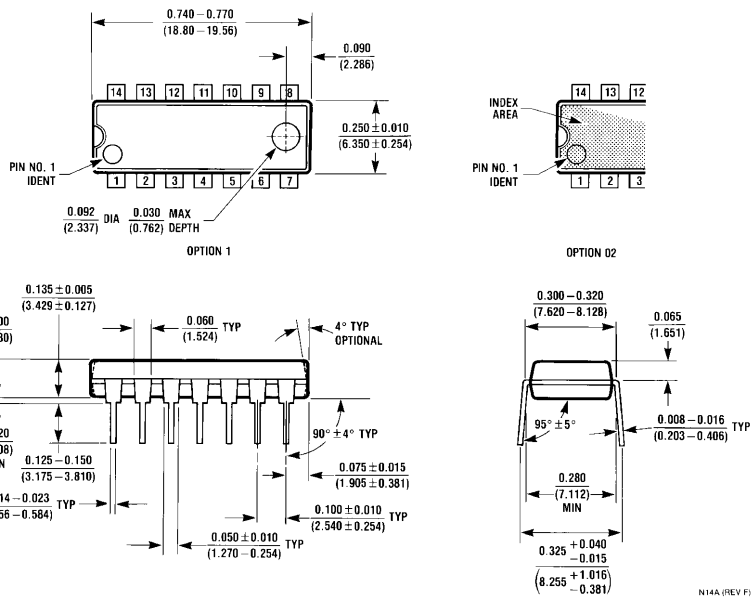

**Molded Dual-In-Line Package (N)**  
**Order Number DM74ALS1005N**  
**Package Number N14A**

**LIFE SUPPORT POLICY**

FAIRCHILD'S PRODUCTS ARE NOT AUTHORIZED FOR USE AS CRITICAL COMPONENTS IN LIFE SUPPORT DEVICES OR SYSTEMS WITHOUT THE EXPRESS WRITTEN APPROVAL OF THE PRESIDENT OF FAIRCHILD SEMICONDUCTOR CORPORATION. As used herein:

1. Life support devices or systems are devices or systems which, (a) are intended for surgical implant into the body, or (b) support or sustain life, and (c) whose failure to perform when properly used in accordance with instructions for use provided in the labeling, can be reasonably expected to result in a significant injury to the user.
2. A critical component in any component of a life support device or system whose failure to perform can be reasonably expected to cause the failure of the life support device or system, or to affect its safety or effectiveness.

**Fairchild Semiconductor Corporation Americas**  
Customer Response Center  
Tel: 1-888-522-5372

**Fairchild Semiconductor Europe**  
Fax: +49 (0) 1 80-530 85 86  
Email: europe.support@nsc.com  
Deutsch Tel: +49 (0) 8 141-35-0  
English Tel: +44 (0) 1 793-85-68-56  
Italy Tel: +39 (0) 2 57 5631

**Fairchild Semiconductor Hong Kong Ltd.**  
13th Floor, Straight Block,  
Ocean Centre, 5 Canton Rd.  
Tsimshatsui, Kowloon  
Hong Kong  
Tel: +852 2737-7200  
Fax: +852 2314-0061

**National Semiconductor Japan Ltd.**  
Tel: 81-3-5620-6175  
Fax: 81-3-5620-6179

[www.fairchildsemi.com](http://www.fairchildsemi.com)