

DM74ALS1032A Quadruple 2-Input OR Buffer

General Description

These devices contain four independent buffers, each of which performs the logic OR function. The 'ALS1032A is a buffer version of the 'ALS32.

- Switching specifications guaranteed over full temperature and V_{CC} range
- Advanced oxide-isolated, ion-implanted Schottky TTL process
- Improved line receiving characteristics

Features

- Switching specifications at 50 pF

Connection Diagram

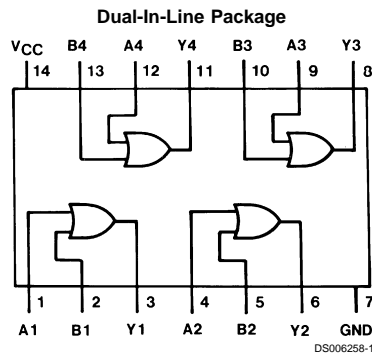

Order Number DM74ALS1032AM or DM74ALS1032AN
See Package Number M14A or N14A

Function Table

$$Y = A + B$$

Inputs		Output
A	B	Y
L	L	L
H	X	H
X	H	H

L = Low Logic Level
H = High Logic Level
X = Either Low or High Logic Level

Absolute Maximum Ratings (Note 1)

Supply Voltage	7V
Input Voltage	7V
Operating Free Air Temperature Range	0°C to +70°C
DM74ALS	

Storage Temperature Range	-65°C to +150°C
Typical θ_{JA}	
N Package	83.0°C/W
M Package	114.0°C/W

Recommended Operating Conditions

Symbol	Parameter	DM74ALS1032A			Units
		Min	Nom	Max	
V_{CC}	Supply Voltage	4.5	5	5.5	V
V_{IH}	High Level Input Voltage	2			V
V_{IL}	Low Level Input Voltage			0.8	V
I_{OH}	High Level Output Current			-2.6	mA
I_{OL}	Low Level Output Current			24	mA
T_A	Free Air Operating Temperature	0		70	°C

Note 1: The "Absolute Maximum Ratings" are those values beyond which the safety of the device cannot be guaranteed. The device should not be operated at these limits. The parametric values defined in the "Electrical Characteristics" table are not guaranteed at the absolute maximum ratings. The "Recommended Operating Conditions" table will define the conditions for actual device operation.

Electrical Characteristics

over recommended operating free air temperature range. All typical values are measured at $V_{CC} = 5V$, $T_A = 25^\circ C$.

Symbol	Parameter	Conditions	Min	Typ	Max	Units
V_{IK}	Input Clamp Voltage	$V_{CC} = 4.5V$, $I_I = -18 mA$			-1.5	V
V_{OH}	High Level Output Voltage	$V_{CC} = 4.5V$ $V_{IH} = 2V$	$I_{OH} = Max$	2.4	3.2	V
		$V_{CC} = 4.5V$ to $5.5V$	$I_{OH} = -400 \mu A$	$V_{CC} - 2$		V
V_{OL}	Low Level Output Voltage	$V_{CC} = 4.5V$ $V_{IH} = 0.8V$	$I_{OL} = 12 mA$	0.25	0.4	V
			$I_{OL} = 24 mA$	0.35	0.5	V
I_I	Input Current at Max Input Voltage	$V_{CC} = 5.5V$, $V_{IH} = 7V$			0.1	mA
I_{IH}	High Level Input Current	$V_{CC} = 5.5V$, $V_{IH} = 2.7V$			20	μA
I_{IL}	Low Level Input Current	$V_{CC} = 5.5V$, $V_{IL} = 0.4V$			-0.1	mA
I_O	Output Drive Current	$V_{CC} = 5.5V$, $V_O = 2.25V$	-30		-112	mA
I_{CCH}	Supply Current with Outputs High	$V_{CC} = 5.5V$, $V_I = 4.5V$		2.5	5	mA
I_{CCL}	Supply Current with Outputs Low	$V_{CC} = 5.5V$, $V_I = 0V$		6.6	10.6	mA

Switching Characteristics

over recommended operating free air temperature range (Note 2)

Symbol	Parameter	Conditions	DM74ALS1032A		Units
			Min	Max	
t_{PLH}	Propagation Delay Time Low to High Level Output	$V_{CC} = 4.5V$ to $5.5V$ $R_L = 500\Omega$	2	9	ns
t_{PHL}	Propagation Delay Time High to Low Level Output	$C_L = 50 pF$	3	12	ns

Note 2: See Section 1 for test waveforms and output load.

Physical Dimensions inches (millimeters) unless otherwise noted

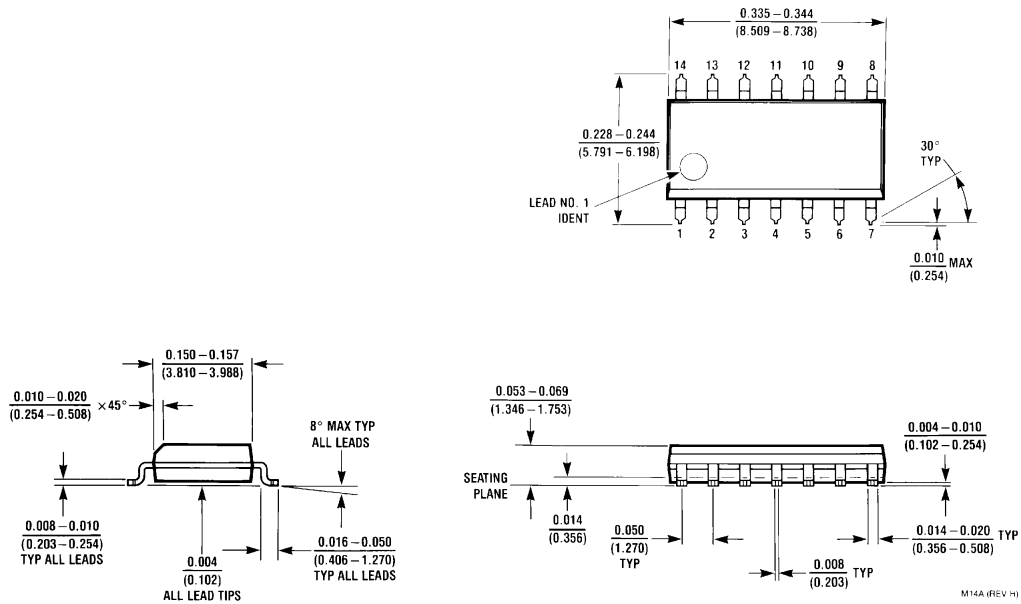

M14A (REV H)

S.O. Package (M)
Order Number DM74ALS1032AM
Package Number M14A

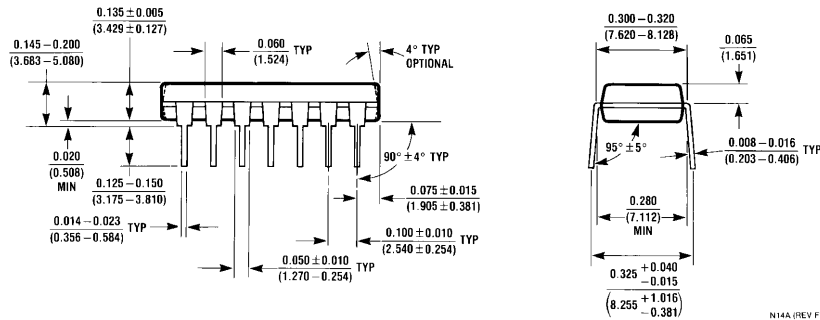
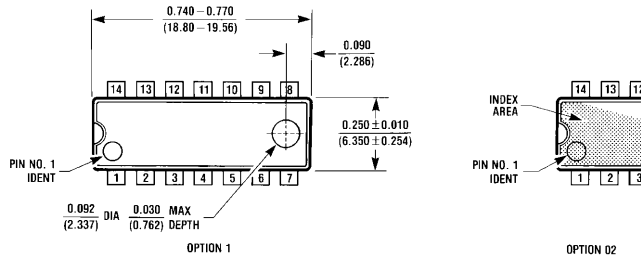

N14A (REV F)

Molded Dual-In-Line Package (N)
Order Number DM74ALS1032AN
Package Number N14A

LIFE SUPPORT POLICY

FAIRCHILD'S PRODUCTS ARE NOT AUTHORIZED FOR USE AS CRITICAL COMPONENTS IN LIFE SUPPORT DEVICES OR SYSTEMS WITHOUT THE EXPRESS WRITTEN APPROVAL OF THE PRESIDENT OF FAIRCHILD SEMICONDUCTOR CORPORATION. As used herein:

1. Life support devices or systems are devices or systems which, (a) are intended for surgical implant into the body, or (b) support or sustain life, and (c) whose failure to perform when properly used in accordance with instructions for use provided in the labeling, can be reasonably expected to result in a significant injury to the user.
2. A critical component in any component of a life support device or system whose failure to perform can be reasonably expected to cause the failure of the life support device or system, or to affect its safety or effectiveness.

Fairchild Semiconductor Corporation Americas
Customer Response Center
Tel: 1-888-522-5372

Fairchild Semiconductor Europe
Fax: +49 (0) 1 80-530 85 86
Email: europe.support@nsc.com
Deutsch Tel: +49 (0) 8 141-35-0
English Tel: +44 (0) 1 793-85-68-56
Italy Tel: +39 (0) 2 57 5631

Fairchild Semiconductor Hong Kong Ltd.
13th Floor, Straight Block,
Ocean Centre, 5 Canton Rd.
Tsimshatsui, Kowloon
Hong Kong
Tel: +852 2737-7200
Fax: +852 2314-0061

National Semiconductor Japan Ltd.
Tel: 81-3-5620-6175
Fax: 81-3-5620-6179

www.fairchildsemi.com