

DM74ALS137

3 to 8 Line Decoder/Demultiplexer with Address Latches

General Description

The ALS137 is a three line to eight line decoder/demultiplexer with latches on the three address inputs. When the latch-enable input (\overline{GL}) is low, the ALS137 acts as a decoder/demultiplexer. When \overline{GL} goes from low to high, the address present at the select inputs (A, B, and C) is stored in the latches. Further address changes are ignored as long as \overline{GL} remains high. The output enable controls, G1 and $\overline{G2}$, control the state of the outputs independently of the select or latch-enable inputs. All of the outputs are high unless G1 is high and $\overline{G2}$ is low. The ALS137 is ideally suited for implementing glitch-free decoders in strobed (stored-address) applications in bus-oriented systems.

Features

- Combines decoder and 3-bit address latch
- Incorporates 3 enable inputs to simplify cascading
- Low power dissipation: 28 mW typ
- Switching specifications guaranteed over full temperature and V_{CC} range
- Advanced oxide-isolated, ion-implanted Schottky TTL process

Connection Diagram

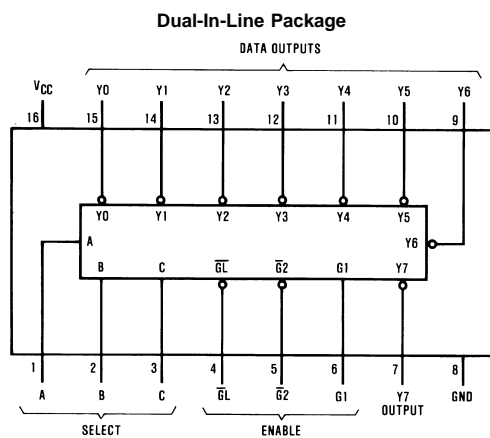

Order Number DM74ALS137M or DM74ALS137N
See Package Number M16A or N16A

DM74ALS137 3 to 8 Line Decoder/Demultiplexer with Address Latches

Function Table

Inputs						Outputs							
Enable			Select										
$\overline{G1}$	G1	$\overline{G2}$	C	B	A	Y0	Y1	Y2	Y3	Y4	Y5	Y6	Y7
X	X	H	X	X	X	H	H	H	H	H	H	H	H
X	L	X	X	X	X	H	H	H	H	H	H	H	H
L	H	L	L	L	L	L	H	H	H	H	H	H	H
L	H	L	L	L	H	H	L	H	H	H	H	H	H
L	H	L	L	H	L	H	H	L	H	H	H	H	H
L	H	L	L	H	H	H	H	H	L	H	H	H	H
L	H	L	H	L	H	H	H	H	H	H	L	H	H
L	H	L	H	H	L	H	H	H	H	H	H	L	H
L	H	L	H	H	H	H	H	H	H	H	H	H	L
H	H	L	X	X	X	Output corresponding to stored address, L; all others, H							

L = Low State, H = High State, X = Don't Care

Absolute Maximum Ratings (Note 1)

Supply Voltage	7V
Input Voltage	7V
Operating Free Air Temperature Range	0°C to +70°C
DM74ALS	

Storage Temperature Range	-65°C to +150°C
Typical θ_{JA}	
N Package	75.5°C/W
M Package	104.0°C/W

Recommended Operating Conditions

Symbol	Parameter	Min	Nom	Max	Units
V_{CC}	Supply Voltage	4.5	5	5.5	V
V_{IH}	High Level Input Voltage	2			V
V_{IL}	Low Level Input Voltage			0.8	V
I_{OH}	High Level Output Current			-0.4	mA
I_{OL}	Low Level Output Current			8	mA
t_W	Width of Enabling Pulse	GL Low	10		ns
t_{SU}	Setup Time (Note 2)	A, B, C	10 \uparrow		ns
t_H	Hold Time (Note 2)	A, B, C	5 \uparrow		ns
T_A	Free Air Operating Temperature	0		70	°C

Note 1: The "Absolute Maximum Ratings" are those values beyond which the safety of the device cannot be guaranteed. The device should not be operated at these limits. The parametric values defined in the "Electrical Characteristics" table are not guaranteed at the absolute maximum ratings. The "Recommended Operating Conditions" table will define the conditions for actual device operation.

Note 2: The arrow (\uparrow) indicates the positive edge of the GL input pulse is used for reference.

Electrical Characteristics

over recommended operating free air temperature range. All typical values are measured at $V_{CC} = 5V$, $T_A = 25^\circ C$.

Symbol	Parameter	Conditions	Min	Typ	Max	Units
V_{IK}	Input Clamp Voltage	$V_{CC} = 4.5V$, $I_I = -18 mA$			-1.5	V
V_{OH}	High Level Output Voltage	$I_{OH} = -0.4 mA$ $V_{CC} = 4.5V$ to $5.5V$	$V_{CC} - 2$			V
V_{OL}	Low Level Output Voltage	$V_{CC} = 4.5V$ $I_{OL} = 4 mA$ $I_{OL} = 8 mA$		0.25	0.4	V
					0.35	0.5
I_I	Input Current @ Max. Input Voltage	$V_{CC} = 5.5V$ $V_{IH} = 7V$	Enable		0.1	mA
			A, B, C		0.1	
I_{IH}	High Level Input Current	$V_{CC} = 5.5V$ $V_{IH} = 2.7V$	Enable		20	μA
			A, B, C		20	
I_{IL}	Low Level Input Current	$V_{CC} = 5.5V$ $V_{IL} = 0.4V$	Enable		-0.1	mA
			A, B, C		-0.1	
I_O	Output Drive Current	$V_{CC} = 5.5V$, $V_O = 2.25V$	-30		-112	mA
I_{CC}	Supply Current	$V_{CC} = 5.5V$		5	11	mA

Switching Characteristics

over recommended operating free air temperature range. (Note 3)

Symbol	Parameter	Conditions	From (Input) To (Output)	Min	Max	Units
t_{PLH}	Propagation Delay Time Low to High Level Output	$V_{CC} = 4.5V$ to $5.5V$ $R_L = 500\Omega$ $C_L = 50 pF$	A, B, C to Y	5	20	ns
t_{PHL}	Propagation Delay Time High to Low Level Output		A, B, C to Y	6	20	ns
t_{PLH}	Propagation Delay Time Low to High Level Output		$\overline{G2}$ to Y	4	12	ns

Switching Characteristics (Continued)

over recommended operating free air temperature range. (Note 3)

Symbol	Parameter	Conditions	From (Input) To (Output)	Min	Max	Units
t_{PHL}	Propagation Delay Time High to Low Level Output		$\overline{G2}$ to Y	5	15	ns
t_{PLH}	Propagation Delay Time Low to High Level Output		G1 to Y	5	17	ns
t_{PHL}	Propagation Delay Time High to Low Level Output		G1 to Y	5	15	ns
t_{PLH}	Propagation Delay Time Low to High Level Output		$\overline{G1}$ to Y	7	22	ns
t_{PHL}	Propagation Delay Time High to Low Level Output		$\overline{G1}$ to Y	7	20	ns

Note 3: See Section 1 for test waveforms and output load.

Logic Diagram

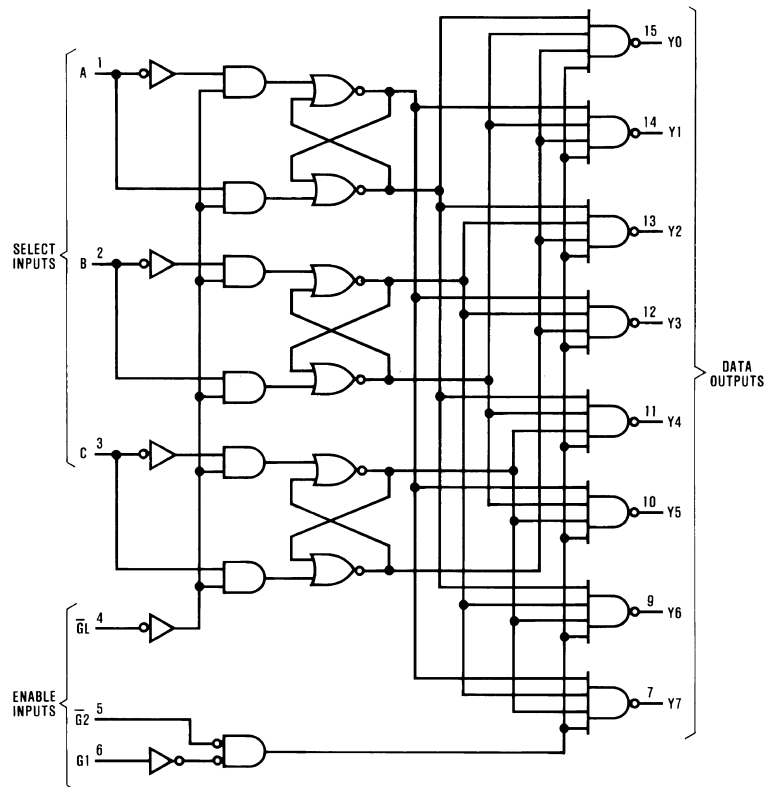

DS006202-2

Physical Dimensions inches (millimeters) unless otherwise noted

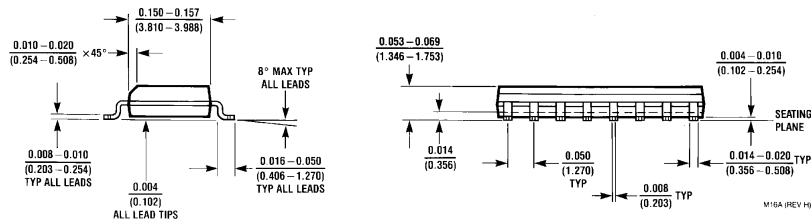
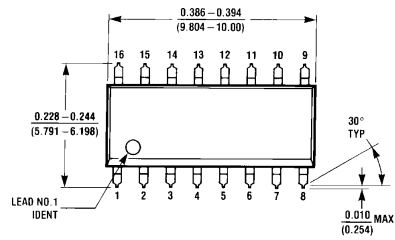

S.O. Package (M)
Order Number DM74ALS137M
Package Number M16A

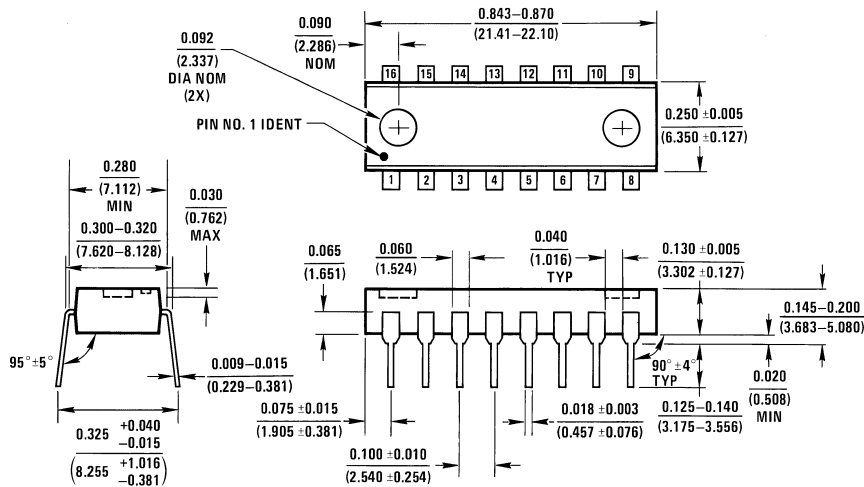

Molded Dual-In-Line Package (N)
Order Number DM74ALS137N
Package Number N16A

LIFE SUPPORT POLICY

FAIRCHILD'S PRODUCTS ARE NOT AUTHORIZED FOR USE AS CRITICAL COMPONENTS IN LIFE SUPPORT DEVICES OR SYSTEMS WITHOUT THE EXPRESS WRITTEN APPROVAL OF THE PRESIDENT OF FAIRCHILD SEMICONDUCTOR CORPORATION. As used herein:

1. Life support devices or systems are devices or systems which, (a) are intended for surgical implant into the body, or (b) support or sustain life, and (c) whose failure to perform when properly used in accordance with instructions for use provided in the labeling, can be reasonably expected to result in a significant injury to the user.
2. A critical component in any component of a life support device or system whose failure to perform can be reasonably expected to cause the failure of the life support device or system, or to affect its safety or effectiveness.

Fairchild Semiconductor Corporation Americas
Customer Response Center
Tel: 1-888-522-5372

Fairchild Semiconductor Europe
Fax: +49 (0) 1 80-530 85 86
Email: europe.support@nsc.com
Deutsch Tel: +49 (0) 8 141-35-0
English Tel: +44 (0) 1 793-85-68-56
Italy Tel: +39 (0) 2 57 5631

Fairchild Semiconductor Hong Kong Ltd.
13th Floor, Straight Block,
Ocean Centre, 5 Canton Rd.
Tsimshatsui, Kowloon
Hong Kong
Tel: +852 2737-7200
Fax: +852 2314-0061

National Semiconductor Japan Ltd.
Tel: 81-3-5620-6175
Fax: 81-3-5620-6179

www.fairchildsemi.com