

## DM74ALS165 8-Bit Parallel In/Serial Out Shift Register

### General Description

The DM74ALS165 is an 8-bit serial register that, when clocked, shifts the data toward serial output,  $\overline{Q}_H$ . Parallel-in access to each stage is provided by eight individual direct data inputs that are enabled by a low level at the  $\overline{SH}/\overline{LD}$  input. The DM74ALS165 also features a clock inhibit function and a complemented serial output,  $\overline{Q}_H$ .

Clocking is accomplished by a low-to-high transition of the CLK input while  $\overline{SH}/\overline{LD}$  is held high and CLK INH is held low. The functions of the CLK and CLK INH (clock inhibit) inputs are interchangeable. Since a low CLK input and a low-to-high transition of CLK INH will also accomplish clock-

ing, CLK INH should be changed to the high level only while the CLK input is high. Parallel loading is inhibited when  $\overline{SH}/\overline{LD}$  is held high. The parallel inputs to the register are enabled while  $\overline{SH}/\overline{LD}$  is low independently of the levels of CLK, CLK INH, or SER inputs.

### Features

- Complementary outputs
- Direct overriding load (data) inputs
- Gated clock inputs
- Parallel-to-serial data conversion

### Connection Diagram

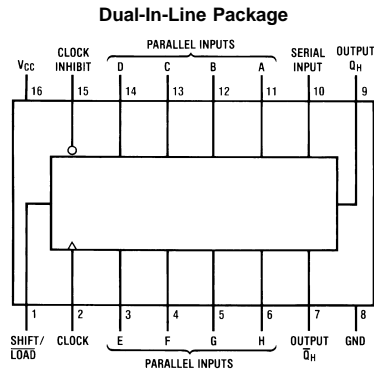

Order Number DM74ALS165M or DM74ALS165N  
See Package Number M16A or N16A

## Function Table

| Shift/<br>Load | Clock<br>Inhibit | Inputs |        |                   | Internal<br>Outputs |                 | Output<br>Q <sub>H</sub> |
|----------------|------------------|--------|--------|-------------------|---------------------|-----------------|--------------------------|
|                |                  | Clock  | Serial | Parallel<br>A...H | Q <sub>A</sub>      | Q <sub>B</sub>  |                          |
|                |                  |        |        |                   | a                   | b               |                          |
| L              | X                | X      | X      | a...h             | a                   | b               | h                        |
| H              | L                | L      | X      | X                 | Q <sub>A0</sub>     | Q <sub>B0</sub> | Q <sub>H0</sub>          |
| H              | L                | ↑      | H      | X                 | H                   | Q <sub>An</sub> | Q <sub>Gn</sub>          |
| H              | L                | ↑      | L      | X                 | L                   | Q <sub>An</sub> | Q <sub>Gn</sub>          |
| H              | ↑                | L      | H      | X                 | H                   | Q <sub>An</sub> | Q <sub>Gn</sub>          |
| H              | ↑                | L      | L      | X                 | L                   | Q <sub>An</sub> | Q <sub>Gn</sub>          |
| H              | H                | X      | X      | X                 | Q <sub>A0</sub>     | Q <sub>B0</sub> | Q <sub>H0</sub>          |

H = High Level (steady-state), L = Low Level (steady-state)

X = Don't Care (any input, including transitions)

↑ = Transition from low-to-high level

a...h = The level of steady-state input at inputs A through H, respectively

Q<sub>A0</sub>, Q<sub>B0</sub>, Q<sub>H0</sub> = The level of Q<sub>A</sub>, Q<sub>B</sub>, or Q<sub>H</sub>, respectively, before the indicated steady-state input conditions were established

Q<sub>An</sub>, Q<sub>Gn</sub> = The level of Q<sub>A</sub> or Q<sub>G</sub>, respectively, before the most recent ↑ transition of the clock

## Absolute Maximum Ratings (Note 1)

|                                      |              |
|--------------------------------------|--------------|
| Supply Voltage                       | 7V           |
| Input Voltage                        | 7V           |
| Operating Free Air Temperature Range | 0°C to +70°C |
| DM74ALS                              |              |

|                           |                 |
|---------------------------|-----------------|
| Storage Temperature Range | -65°C to +150°C |
| Typical $\theta_{JA}$     |                 |
| N Package                 | 74.0°C/W        |
| M Package                 | 104.0°C/W       |

## Recommended Operating Conditions

| Symbol      | Parameter                      | DM74ALS165           |     |      | Units |
|-------------|--------------------------------|----------------------|-----|------|-------|
|             |                                | Min                  | Typ | Max  |       |
| $V_{CC}$    | Supply Voltage                 | 4.5                  | 5   | 5.5  | V     |
| $V_{IH}$    | High Level Input Voltage       | 2                    |     |      | V     |
| $V_{IL}$    | Low Level Input Voltage        |                      |     | 0.8  | V     |
| $I_{OH}$    | High Level Output Current      |                      |     | -0.4 | mA    |
| $I_{OL}$    | Low Level Output Current       |                      |     | 8    | mA    |
| $f_{CLOCK}$ | Clock Frequency                | 45                   |     |      | MHz   |
| $t_w$       | Pulse Duration                 | CLK High             | 11  |      | ns    |
|             |                                | CLK Low              | 11  |      |       |
|             |                                | Load                 | 12  |      |       |
| $t_{SU}$    | Setup Time                     | SH/LD                | 10  |      | ns    |
|             |                                | Data                 | 10  |      |       |
| $t_{SU}$    | Setup Time                     | CLK INH ↓ before CLK | 11  |      | ns    |
|             |                                | Serial before CLK    | 10  |      |       |
| $t_H$       | Hold Time                      | 4                    |     |      | ns    |
| $T_A$       | Operating Free Air Temperature | 0                    |     | 70   | °C    |

**Note 1:** The "Absolute Maximum Ratings" are those values beyond which the safety of the device cannot be guaranteed. The device should not be operated at these limits. The parametric values defined in the "Electrical Characteristics" table are not guaranteed at the absolute maximum ratings. The "Recommended Operating Conditions" table will define the conditions for actual device operation.

## Electrical Characteristics

over recommended operating free air temperature range (unless otherwise noted)

| Symbol         | Parameter                          | Conditions  | DM74ALS165   |                 |      | Units |
|----------------|------------------------------------|---|--------------|-----------------|------|-------|
|                |                                    |   | Min          | Typ<br>(Note 2) | Max  |       |
| $V_{IK}$       | Input Clamp Voltage                | $V_{CC} = 4.5V, I_I = -18\text{ mA}$                                |              |                 | -1.5 | V     |
| $V_{OH}$       | High Level Output Voltage          | $I_{OH} = -0.4\text{ mA}$<br>$V_{CC} = 4.5V\text{ to }5.5V$         | $V_{CC} - 2$ |                 |      | V     |
| $V_{OL}$       | Low Level Output Voltage           | $V_{CC} = 4.5V$<br>$I_{OL} = 4\text{ mA}$<br>$I_{OL} = 8\text{ mA}$ |              | 0.25            | 0.4  | V     |
|                |                                    |   |              | 0.35            | 0.5  |       |
| $I_I$          | Input Current at Max Input Voltage | $V_{CC} = 5.5V, V_I = 7V$   |              |                 | 0.1  | mA    |
| $I_{IH}$       | High Level Input Current           | $V_{CC} = 5.5V, V_I = 2.7V$   |              |                 | 20   | μA    |
| $I_{IL}$       | Low Level Input Current            | $V_{CC} = 5.5V, V_I = 0.4V$   |              |                 | -0.1 | mA    |
| $I_O$ (Note 3) | Output Drive Current               | $V_{CC} = 5.5V, V_O = 2.25V$  | -30          |                 | -112 | mA    |
| $I_{CC}$       | Supply Current                     | $V_{CC} = 5.5V$ (Note 4)  |              | 16              | 24   | mA    |

## Switching Characteristics

over recommended free air temperature range (Note 5) . All typical values are measured at  $V_{CC} = 5V$ ,  $T_A = 25^\circ C$ .

| Symbol    | Parameter  | Input | Output                       | Conditions  | DM74ALS165 |     |     | Units |
|-----------|--|-------|------------------------------|---|------------|-----|-----|-------|
|           |  |       |                              |   | Min        | Typ | Max |       |
| $f_{MAX}$ | Maximum Frequency                                  |       |                              | $V_{CC} = 4.5V$ to $5.5V$ ,   | 45         | 60  |     | MHz   |
| $t_{PLH}$ | Propagation Delay Time<br>Low to High Level Output | Load  | $Q_H$<br>or $\overline{Q}_H$ | $C_L = 50$ pF,<br>$R_L = 500\Omega$<br>$T_A = \text{Min}$<br>to Max | 4          | 13  | 20  | ns    |
| $t_{PHL}$ | Propagation Delay Time<br>High to Low Level Output | Load  | $Q_H$<br>or $\overline{Q}_H$ |   | 4          | 14  | 22  |       |
| $t_{PLH}$ | Propagation Delay Time<br>Low to High Level Output | CLK   | $Q_H$<br>or $\overline{Q}_H$ |   | 3          | 7   | 13  | ns    |
| $t_{PHL}$ | Propagation Delay Time<br>High to Low Level Output | CLK   | $Q_H$<br>or $\overline{Q}_H$ |   | 3          | 9   | 14  |       |
| $t_{PLH}$ | Propagation Delay Time<br>Low to High Level Output | H     | $Q_H$                        |   | 3          | 7   | 13  | ns    |
| $t_{PHL}$ | Propagation Delay Time<br>High to Low Level Output | H     | $Q_H$                        |   | 3          | 9   | 16  |       |
| $t_{PLH}$ | Propagation Delay Time<br>Low to High Level Output | H     | $\overline{Q}_H$             |   | 2          | 8   | 15  | ns    |
| $t_{PHL}$ | Propagation Delay Time<br>High to Low Level Output | H     | $\overline{Q}_H$             |   | 3          | 9   | 16  |       |

**Note 2:** All typical values are at  $V_{CC} = 5V$ ,  $T_A = 25^\circ C$ .

**Note 3:** The output conditions have been chosen to produce a current that closely approximates one half of the true short-circuit output current,  $I_{OS}$ .

**Note 4:** With the outputs open, CLK INH and CLK at 4.5V, and a clock pulse applied to the SH/LD input,  $I_{CC}$  is measured first with the parallel inputs at 4.5V, then with the parallel inputs grounded.

**Note 5:** See Section 1 for test waveforms and output load.

# Logic Diagram

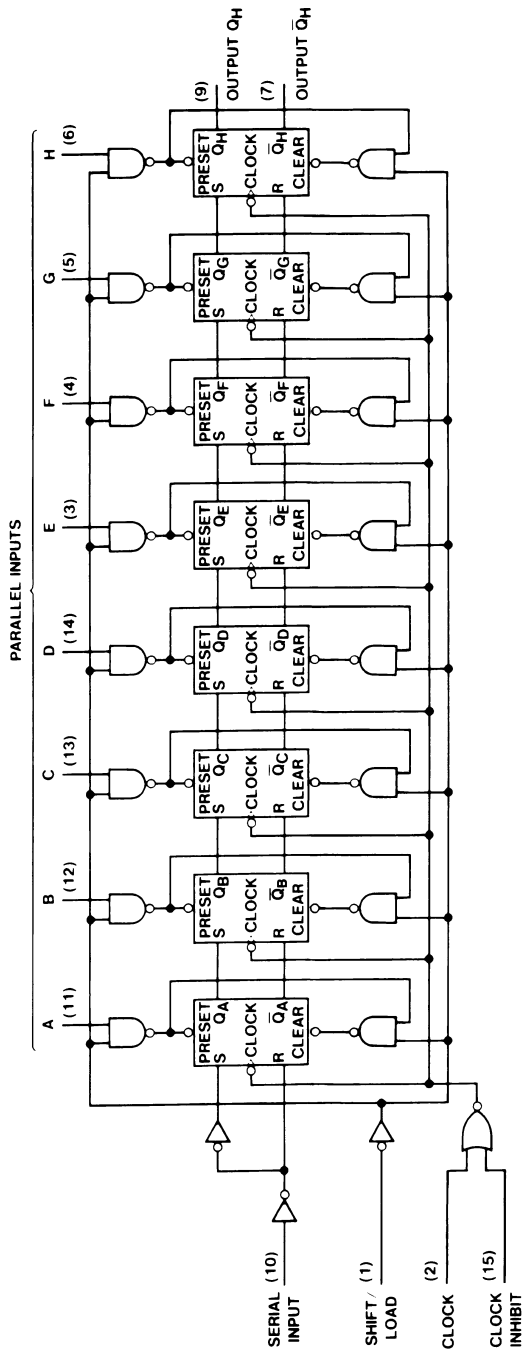

DS9087122

# Timing Diagram

Typical Shift, Load, and Inhibit Sequences

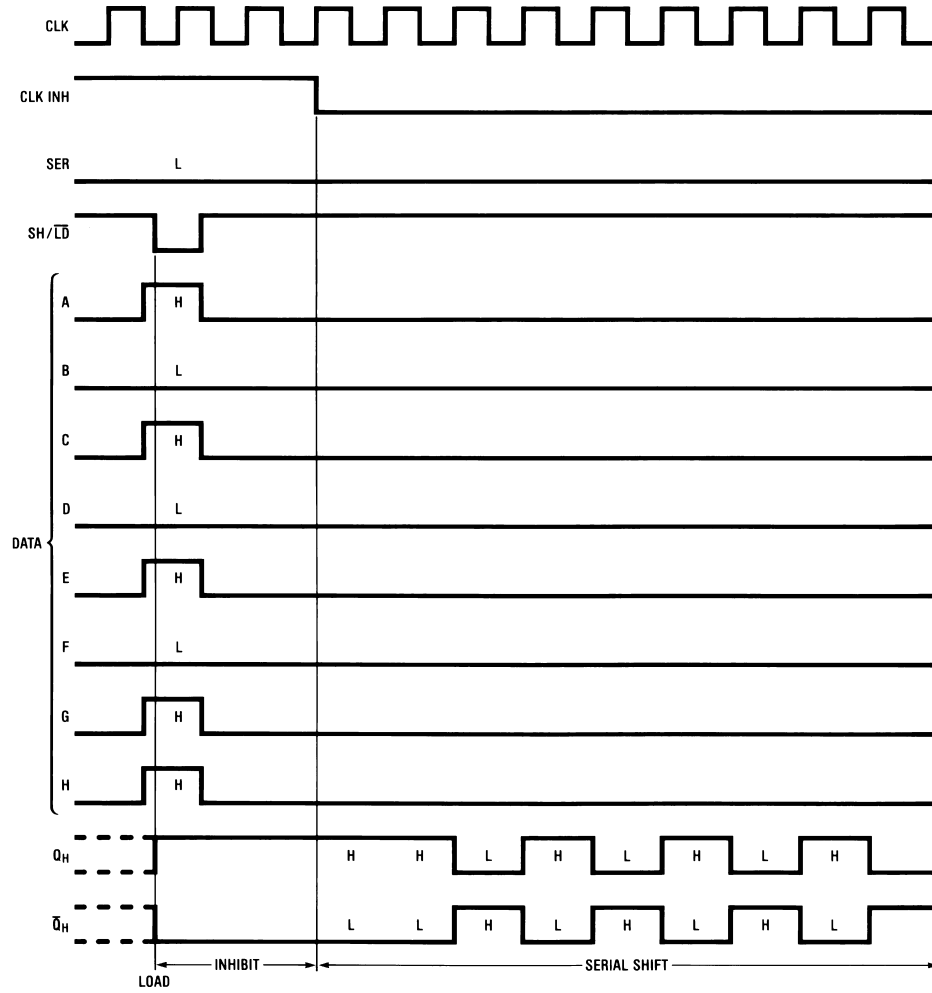

DS006712-3

**Physical Dimensions** inches (millimeters) unless otherwise noted

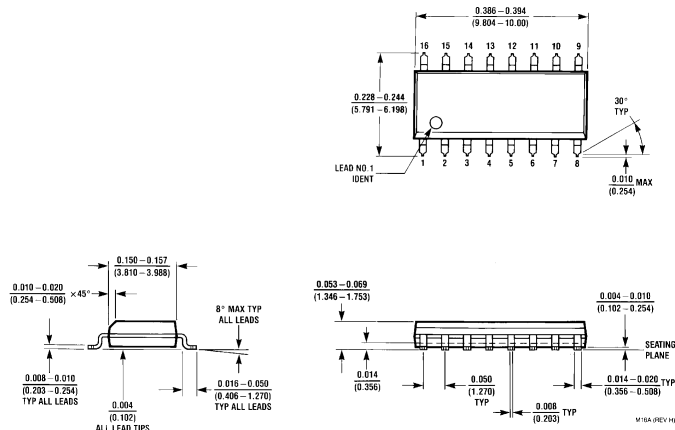

**Small Outline Package (M)**  
**Order Number DM74ALS165M**  
**Package Number M16A**

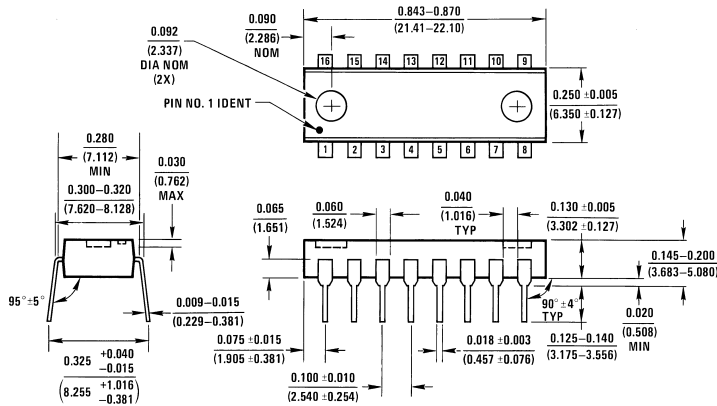

**Molded Dual-In-Line Package (N)**  
**Order Number DM74ALS165N**  
**Package Number N16A**

**LIFE SUPPORT POLICY**

FAIRCHILD'S PRODUCTS ARE NOT AUTHORIZED FOR USE AS CRITICAL COMPONENTS IN LIFE SUPPORT DEVICES OR SYSTEMS WITHOUT THE EXPRESS WRITTEN APPROVAL OF THE PRESIDENT OF FAIRCHILD SEMICONDUCTOR CORPORATION. As used herein:

1. Life support devices or systems are devices or systems which, (a) are intended for surgical implant into the body, or (b) support or sustain life, and (c) whose failure to perform when properly used in accordance with instructions for use provided in the labeling, can be reasonably expected to result in a significant injury to the user.
2. A critical component in any component of a life support device or system whose failure to perform can be reasonably expected to cause the failure of the life support device or system, or to affect its safety or effectiveness.

**Fairchild Semiconductor Corporation Americas**  
Customer Response Center  
Tel: 1-888-522-5372

**Fairchild Semiconductor Europe**  
Fax: +49 (0) 1 80-530 85 86  
Email: europe.support@nsc.com  
Deutsch Tel: +49 (0) 8 141-35-0  
English Tel: +44 (0) 1 793-85-68-56  
Italy Tel: +39 (0) 2 57 5631

**Fairchild Semiconductor Hong Kong Ltd.**  
13th Floor, Straight Block,  
Ocean Centre, 5 Canton Rd.  
Tsimshatsui, Kowloon  
Hong Kong  
Tel: +852 2737-7200  
Fax: +852 2314-0061

**National Semiconductor Japan Ltd.**  
Tel: 81-3-5620-6175  
Fax: 81-3-5620-6179

[www.fairchildsemi.com](http://www.fairchildsemi.com)