

DM74ALS169B Synchronous Four-Bit Up/Down Counters

General Description

These synchronous presettable counters feature an internal carry look ahead for cascading in high speed counting applications. The ALS169B is a four-bit binary up/down counter. The carry output is decoded to prevent spikes during normal mode of counting operation. Synchronous operation is provided so that outputs change coincident with each other when so instructed by count enable inputs and internal gating. This mode of operation eliminates the output counting spikes which are normally associated with asynchronous (ripple clock) counters. A buffered clock input triggers the four flip-flops on the rising (positive going) edge of clock input waveform.

These counters are fully programmable; that is, the outputs may each be preset either high or low. The load input circuitry allows loading with carry-enable output of cascaded counters. As loading is synchronous, setting up a low level at the load input disables the counter and causes the outputs to agree with the data inputs after the next clock pulse.

The carry look-ahead circuitry permits cascading counters for n-bit synchronous applications without additional gating. Both count enable inputs (\bar{P} and \bar{T}) must be low to count. The direction of the count is determined by the level of the up/down input. When the input is high, the counter counts up; when low, it counts down. Input T is fed forward to enable the carry outputs. The carry output thus enabled will produce a low level output pulse with a duration approximately equal to the high portion of the Q_A output when counting up, and

approximately equal to the low portion of the Q_A when counting down. This low level overflow carry pulse can be used to enable successively cascaded stages. Transitions at the enable \bar{P} or \bar{T} inputs are allowed regardless of the level of the clock input.

The control functions for these counters are fully synchronous. Changes at control inputs (enable \bar{P} , enable \bar{T} , load, up/down) which modify the operating mode have no effect until clocking occurs. The function of the counter (whether enabled, disabled, loading or counting) will be dictated solely by the conditions meeting the stable setup and hold times.

Features

- Switching specifications at 50 pF
- Switching specifications guaranteed over full temperature and V_{CC} range
- Advanced oxide-isolated, ion-implanted Schottky TTL process
- Functionally and pin-for-pin compatible with Schottky and low power Schottky TTL counterpart
- Improved AC performance over Schottky and low power Schottky counterparts
- Synchronously programmable
- Internal look ahead for fast counting
- Carry output for n-bit cascading
- Synchronous counting
- ESD inputs

Connection Diagram

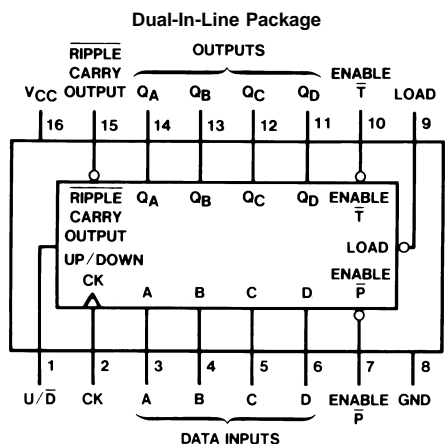

DS006207-1

Order Number DM74ALS169BM or 169BN
See Package Number M16A or N16A

Absolute Maximum Ratings (Note 1)

Supply Voltage	7V
Input Voltage	7V
Operating Free Air Temperature Range	0°C to +70°C
DM74LS	

Storage Temperature Range

-65°C to +150°C

Typical θ_{JA}

N Package

78.1°C/W

M Package

106.8°C/W

Recommended Operating Conditions

Symbol	Parameter		DM74ALS169B			Units
			Min	Nom	Max	
V_{CC}	Supply Voltage		4.5	5	5.5	V
V_{IH}	High Level Input Voltage		2			V
V_{IL}	Low Level Input Voltage				0.8	V
I_{OH}	High Level Output Current				-0.4	mA
I_{OL}	Low Level Output Current				8	mA
f_{CLK}	Clock Frequency		0		40	MHz
t_{SU}	Setup Time	Data; A, B, C, D	15 \uparrow	6		ns
		En \bar{P} , En \bar{T}	15 \uparrow	8		ns
		\overline{Load}	15 \uparrow	8		ns
		U/ \bar{D}	15 \uparrow	10		ns
t_H	Hold Time	Data; A, B, C, D	0 \uparrow	-3		ns
		En \bar{P} , En \bar{T}	0 \uparrow	-3		ns
		\overline{Load}	0 \uparrow	-4		ns
		U/ \bar{D}	0 \uparrow	-4		ns
t_W	Width of Clock Pulse		13			ns

Note 1: The "Absolute Maximum Ratings" are those values beyond which the safety of the device cannot be guaranteed. The device should not be operated at these limits. The parametric values defined in the "Electrical Characteristics" table are not guaranteed at the absolute maximum ratings. The "Recommended Operating Conditions" table will define the conditions for actual device operation.

Note 2: The symbol (\uparrow) indicates that the rising edge of the clock is used as reference.

Electrical Characteristics

over recommended operating free air temperature range. All typical values are measured at $V_{CC} = 5V$, $T_A = 25^\circ C$

Symbol	Parameter	Conditions	Min	Typ	Max	Units
V_{IK}	Input Clamp Voltage	$V_{CC} = 4.5V$, $I_I = -18\text{ mA}$			-1.5	V
V_{OH}	High Level Output Voltage	$I_{OH} = -0.4\text{ mA}$ $V_{CC} = 4.5V\text{ to }5.5V$	$V_{CC} - 2$			V
V_{OL}	Low Level Output Voltage	$V_{CC} = 4.5V$ 74ALS $I_{OL} = 8\text{ mA}$		0.35	0.5	V
I_I	Input Current @ Max Input Voltage	$V_{CC} = 5.5V$, $V_{IH} = 7V$			0.1	mA
I_{IH}	High Level Input Current	$V_{CC} = 5.5V$, $V_{IH} = 2.7V$			20	μA
I_{IL}	Low Level Input Current	$V_{CC} = 5.5V$, $V_{IL} = 0.4V$			-0.2	mA
I_O	Output Drive Current	$V_{CC} = 5.5V$, $V_O = 2.25V$	-30		-112	mA
I_{CC}	Supply Current	$V_{CC} = 5.5V$		15	25	mA

Switching Characteristics

over recommended operating free air temperature range (Note 3)

Symbol	Parameter	Conditions	From	To	DM74ALS169B		Units
					Min	Max	
f_{MAX}	Max. Clock Freq.				40		MHz
t_{PLH}	Propagation Delay Time Low to High Level Output	$V_{CC} = 4.5V$ to $5.5V$ $R_L = 500\Omega$ $C_L = 50 pF$	Clock	Ripple Carry	3	20	ns
t_{PHL}	Propagation Delay Time High to Low Level Output		Clock	Ripple Carry	6	20	ns
t_{PLH}	Propagation Delay Time Low to High Level Output		Clock	Any Q	2	15	ns
t_{PHL}	Propagation Delay Time High to Low Level Output		Clock	Any Q	5	20	ns
t_{PLH}	Propagation Delay Time Low to High Level Output		En T	Ripple Carry	2	13	ns
t_{PHL}	Propagation Delay Time High to Low Level Output		En T	Ripple Carry	3	16	ns
t_{PLH}	Propagation Delay Time Low to High Level Output		U/ \bar{D} (Note 4)	Ripple Carry	5	19	ns
t_{PHL}	Propagation Delay Time High to Low Level Output		U/ \bar{D} (Note 4)	Ripple Carry	5	19	ns

Note 3: See Section 1 for test waveforms and output load.

Note 4: Propagation delay time from up/down to ripple carry must be measured with the counter at either a minimum or a maximum count. As the logic level of the up/down input is changed, the ripple carry output will follow. If the count is minimum (0), the ripple carry output transition will be in phase. If the count is maximum (9 for ALS168B or 15 for ALS169B), the ripple carry output will be out of phase.

Logic Diagram

DM74ALS169B

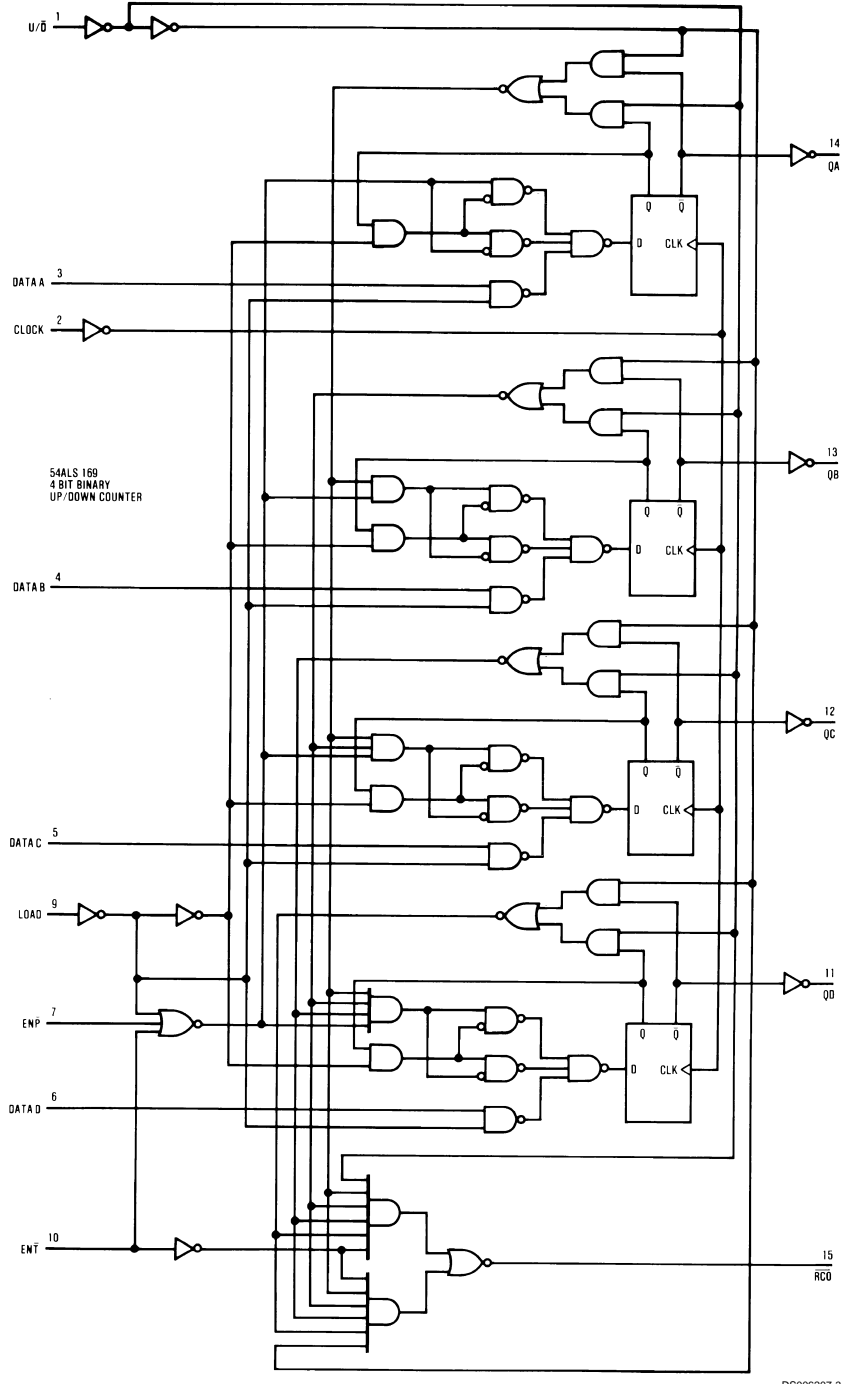

DS006207-3

Physical Dimensions inches (millimeters) unless otherwise noted

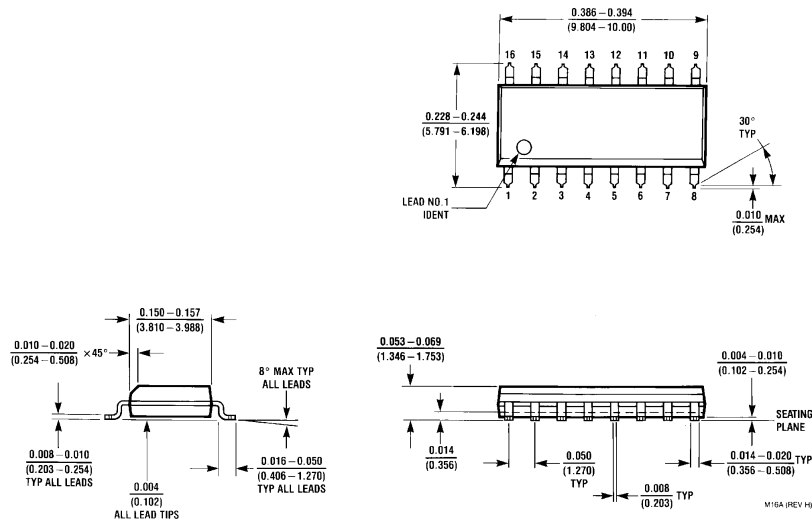

S.O. Package (M)
Order Number DM74ALS169BM
Package Number M16A

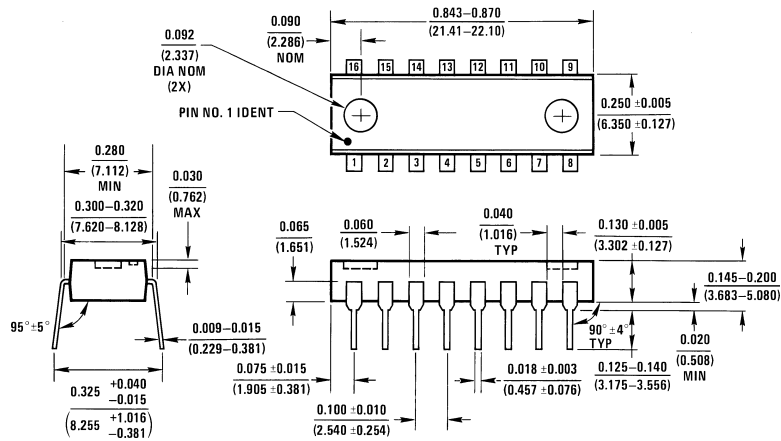

Molded Dual-In-Line Package (N)
Order Number DM74ALS169BN
Package Number N16A

LIFE SUPPORT POLICY

FAIRCHILD'S PRODUCTS ARE NOT AUTHORIZED FOR USE AS CRITICAL COMPONENTS IN LIFE SUPPORT DEVICES OR SYSTEMS WITHOUT THE EXPRESS WRITTEN APPROVAL OF THE PRESIDENT OF FAIRCHILD SEMICONDUCTOR CORPORATION. As used herein:

1. Life support devices or systems are devices or systems which, (a) are intended for surgical implant into the body, or (b) support or sustain life, and (c) whose failure to perform when properly used in accordance with instructions for use provided in the labeling, can be reasonably expected to result in a significant injury to the user.
2. A critical component in any component of a life support device or system whose failure to perform can be reasonably expected to cause the failure of the life support device or system, or to affect its safety or effectiveness.

Fairchild Semiconductor Corporation Americas
Customer Response Center
Tel: 1-888-522-5372

Fairchild Semiconductor Europe
Fax: +49 (0) 1 80-530 85 86
Email: europe.support@nsc.com
Deutsch Tel: +49 (0) 8 141-35-0
English Tel: +44 (0) 1 793-85-68-56
Italy Tel: +39 (0) 2 57 5631

Fairchild Semiconductor Hong Kong Ltd.
13th Floor, Straight Block,
Ocean Centre, 5 Canton Rd.
Tsimshatsui, Kowloon
Hong Kong
Tel: +852 2737-7200
Fax: +852 2314-0061

National Semiconductor Japan Ltd.
Tel: 81-3-5620-6175
Fax: 81-3-5620-6179

www.fairchildsemi.com