

DM74ALS251 3-STATE 1 of 8 Line Data Selector/Multiplexer

General Description

This Data Selector/Multiplexer contains full on-chip decoding to select one-of-eight data sources as a result of a unique three-bit binary code at the Select inputs. Two complementary outputs provide both inverting and non-inverting buffer operation. An Output Control input is provided which, when at the high level, places both outputs in the high impedance Off state. In order to prevent bus access conflicts, output disable times are shorter than output enable times. The Select input buffers incorporate internal overlap features to ensure that select input changes do not cause invalid output transients.

Features

- Advanced oxide-isolated, ion-implanted Schottky TTL process
- Switching performance is guaranteed over full temperature and V_{CC} supply range
- Pin and functional compatible with LS family counterpart
- Improved output transient handling capability
- Output control circuitry incorporates power-up 3-STATE feature

Connection Diagram

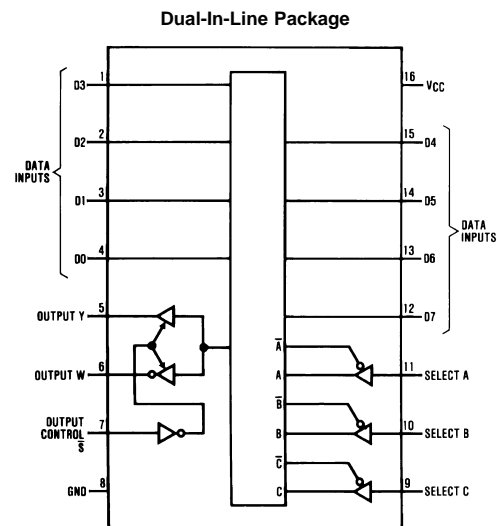

DS006214-1

Order Number DM74ALS251M or DM74ALS251N
See Package Number M16A or N16A

Function Table

Inputs				Outputs	
Select			Strobe		
C	B	A	\bar{S}	Y	W
X	X	X	H	Z	Z
L	L	L	L	D0	$\overline{D0}$
L	L	H	L	D1	$\overline{D1}$
L	H	L	L	D2	$\overline{D2}$
L	H	H	L	D3	$\overline{D3}$
H	L	L	L	D4	$\overline{D4}$
H	L	H	L	D5	$\overline{D5}$
H	H	L	L	D6	$\overline{D6}$
H	H	H	L	D7	$\overline{D7}$

H = High Level
L = Low Level
X = Don't Care
Z = High Impedance (Off)
D0 thru D7 = The Level of the Respective D Input

Absolute Maximum Ratings (Note 1)

Supply Voltage, V_{CC}	7V	DM74ALS251	0°C to +70°C
Input Voltage	7V	Storage Temperature Range	-65°C to +150°C
Voltage Applied to Disabled Output	5.5V	Typical θ_{JA}	
Operating Free Air Temperature Range		N Package	78.0°C/W
		M Package	107.0°C/W

Recommended Operating Conditions

Symbol	Parameter	Min	Nom	Max	Units
V_{CC}	Supply Voltage	4.5	5	5.5	V
V_{IH}	High Level Input Voltage	2			V
V_{IL}	Low Level Input Voltage			0.8	V
I_{OH}	High Level Output Current			-2.6	mA
I_{OL}	Low Level Output Current			24	mA
T_A	Free Air Operating Temperature	0		70	°C

Note 1: The "Absolute Maximum Ratings" are those values beyond which the safety of the device cannot be guaranteed. The device should not be operated at these limits. The parametric values defined in the "Electrical Characteristics" table are not guaranteed at the absolute maximum ratings. The "Recommended Operating Conditions" table will define the conditions for actual device operation.

Electrical Characteristics

over recommended operating free air temperature range. All typical values are measured at $V_{CC} = 5V$, $T_A = 25^\circ C$.

Symbol	Parameter	Conditions		Min	Typ	Max	Units
V_{IK}	Input Clamp Voltage	$V_{CC} = 4.5V$, $I_{IN} = -18\text{ mA}$				-1.5	V
V_{OH}	High Level Output Voltage	$V_{CC} = 4.5V$, $I_{OH} = \text{Max}$		2.4	3.2		V
		$I_{OH} = -400\ \mu A$, $V_{CC} = 4.5V$ to $5.5V$		$V_{CC}-2$			V
V_{OL}	Low Level Output Voltage	$V_{CC} = 4.5V$	$I_{OL} = 24\text{ mA}$		0.35	0.5	V
I_I	Input Current at Max Input Voltage	$V_{CC} = 5.5V$, $V_{IH} = 7V$				0.1	mA
I_{IH}	High Level Input Current	$V_{CC} = 5.5V$, $V_{IH} = 2.7V$				20	μA
I_{IL}	Low Level Input Current	$V_{CC} = 5.5V$, $V_{IL} = 0.4V$				-0.1	mA
I_O	Output Drive Current	$V_{CC} = 5.5V$, $V_{OUT} = 2.25V$		-30		-112	mA
I_{OZH}	Off-State Output Current, High Bias	$V_{CC} = 5.5V$, $V_{OUT} = 2.7V$				20	μA
I_{OZL}	Off-State Output Current, Low Bias	$V_{CC} = 5.5V$, $V_{OUT} = 0.4V$				-20	μA
I_{CC}	Supply Current	$V_{CC} = 5.5V$, Inputs = GND	Enabled		7	10	mA
		Inputs = 4.5V, $V_{CC} = 5.5V$	Disabled		9.4	14	

Switching Characteristics

over recommended operating free air temperature range (Note 2)

Symbol	Parameter	From	To	Conditions	Min	Max	Units
t _{PLH}	Propagation Delay Time Low to High Level Output	Select	Y	V _{CC} = 4.5V to 5.5V C _L = 50 pF R _L = 500Ω	5	18	ns
t _{PHL}	Propagation Delay Time High to Low Level Output	Select			8	24	ns
t _{PLH}	Propagation Delay Time Low to High Level Output	Select	W		8	24	ns
t _{PHL}	Propagation Delay Time High to Low Level Output	Select			7	23	ns
t _{PLH}	Propagation Delay Time Low to High Level Output	Data	Y		2	10	ns
t _{PHL}	Propagation Delay Time High to Low Level Output	Data			3	15	ns
t _{PLH}	Propagation Delay Time Low to High Level Output	Data	W		3	15	ns
t _{PHL}	Propagation Delay Time High to Low Level Output	Data			3	15	ns
t _{PZH}	Output Enable Time to High Level	Output Control	Y		3	15	ns
t _{PZL}	Output Enable Time to Low Level	Output Control			3	15	ns
t _{PZH}	Output Enable Time to High Level	Output Control	W		3	15	ns
t _{PZL}	Output Enable Time to Low Level	Output Control			3	15	ns
t _{PHZ}	Output Disable Time from High Level	Output Control	Y		2	10	ns
t _{PLZ}	Output Disable Time from Low Level	Output Control			1	10	ns
t _{PHZ}	Output Disable Time from High Level	Output Control	W		2	10	ns
t _{PLZ}	Output Disable Time from Low Level	Output Control			1	10	ns

Note 2: See Section 1 for test waveforms and output load.

Logic Diagram

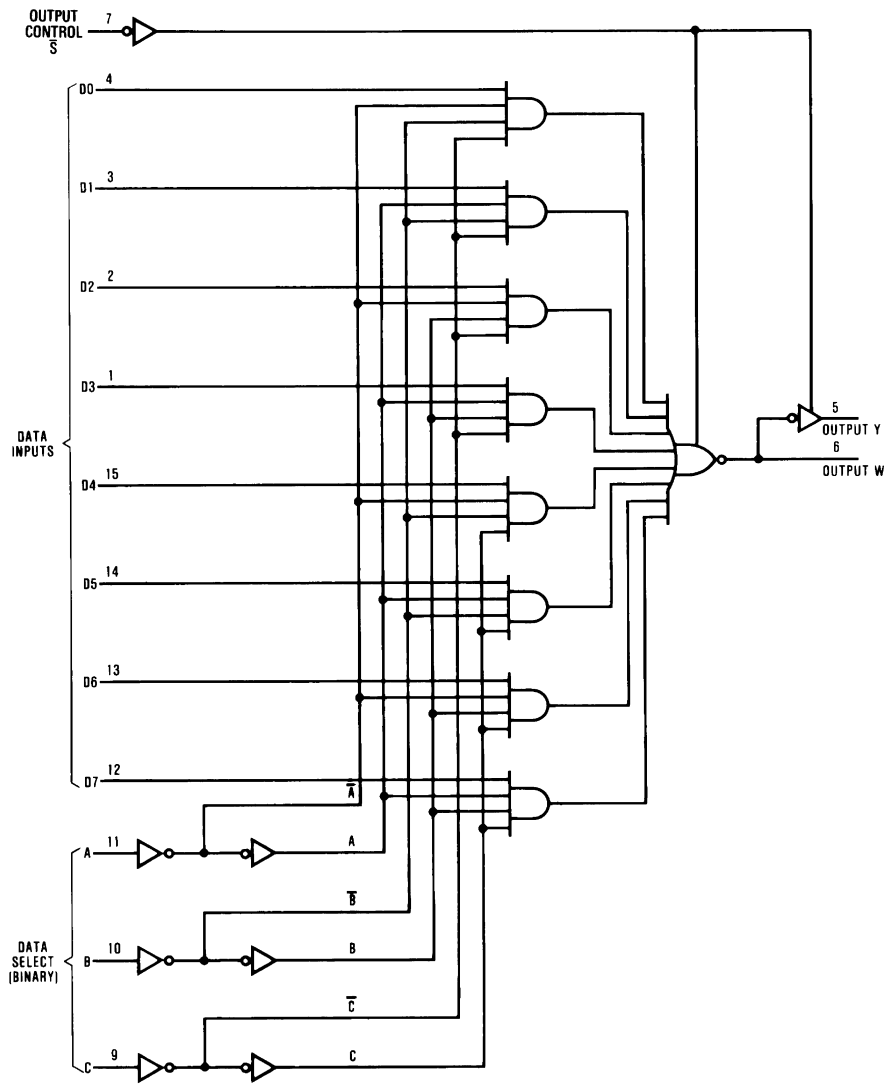

DS006214-2

Physical Dimensions inches (millimeters) unless otherwise noted

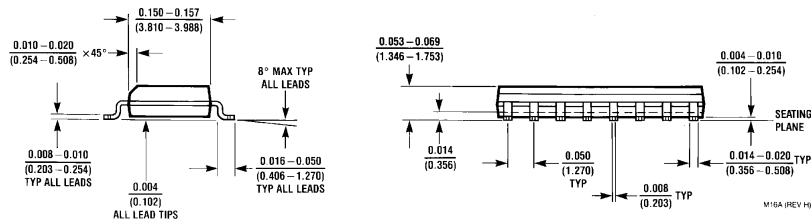
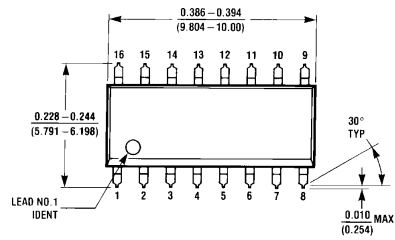

S.O. Package (M)
Order Number DM74ALS251M
Package Number M16A

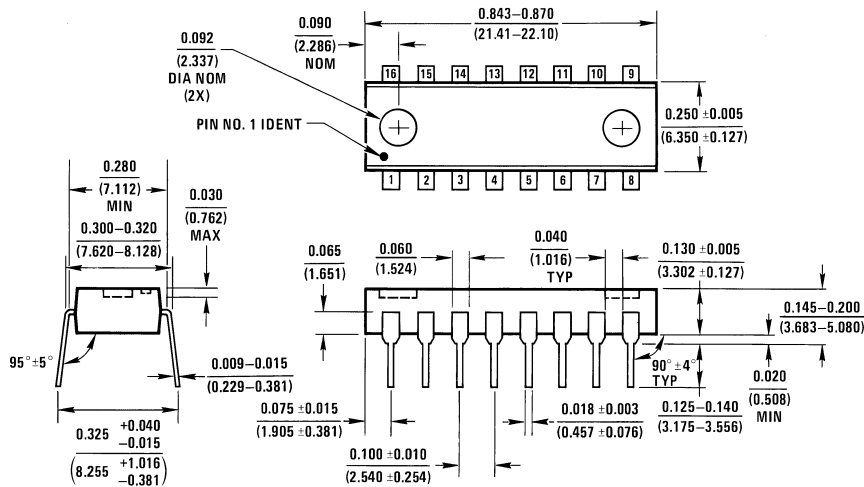

Molded Dual-In-Line Package (N)
Order Number DM74ALS251N
Package Number N16A

LIFE SUPPORT POLICY

FAIRCHILD'S PRODUCTS ARE NOT AUTHORIZED FOR USE AS CRITICAL COMPONENTS IN LIFE SUPPORT DEVICES OR SYSTEMS WITHOUT THE EXPRESS WRITTEN APPROVAL OF THE PRESIDENT OF FAIRCHILD SEMICONDUCTOR CORPORATION. As used herein:

1. Life support devices or systems are devices or systems which, (a) are intended for surgical implant into the body, or (b) support or sustain life, and (c) whose failure to perform when properly used in accordance with instructions for use provided in the labeling, can be reasonably expected to result in a significant injury to the user.
2. A critical component in any component of a life support device or system whose failure to perform can be reasonably expected to cause the failure of the life support device or system, or to affect its safety or effectiveness.

Fairchild Semiconductor Corporation Americas
Customer Response Center
Tel: 1-888-522-5372

Fairchild Semiconductor Europe
Fax: +49 (0) 1 80-530 85 86
Email: europe.support@nsc.com
Deutsch Tel: +49 (0) 8 141-35-0
English Tel: +44 (0) 1 793-85-68-56
Italy Tel: +39 (0) 2 57 5631

Fairchild Semiconductor Hong Kong Ltd.
13th Floor, Straight Block,
Ocean Centre, 5 Canton Rd.
Tsimshatsui, Kowloon
Hong Kong
Tel: +852 2737-7200
Fax: +852 2314-0061

National Semiconductor Japan Ltd.
Tel: 81-3-5620-6175
Fax: 81-3-5620-6179

www.fairchildsemi.com