

DM74ALS541 Octal Buffer and Line Driver with 3-STATE Outputs

General Description

This octal buffer and line driver is designed to have the performance of the 'ALS240 series and, at the same time, offer a pinout with inputs and outputs on opposite sides of the package. This arrangement greatly enhances circuit board layout. The 3-STATE control gate is a 2-input NOR such that if either G1 or G2 is high, all eight outputs are in the high impedance state.

- Switching performance is guaranteed over full temperature and V_{CC} supply range
- Data flow-thru pinout (all inputs on opposite side from outputs)
- P-N-P Inputs reduce DC loading

Features

- Advanced oxide-isolated ion-implanted Schottky TTL process

Connection Diagram

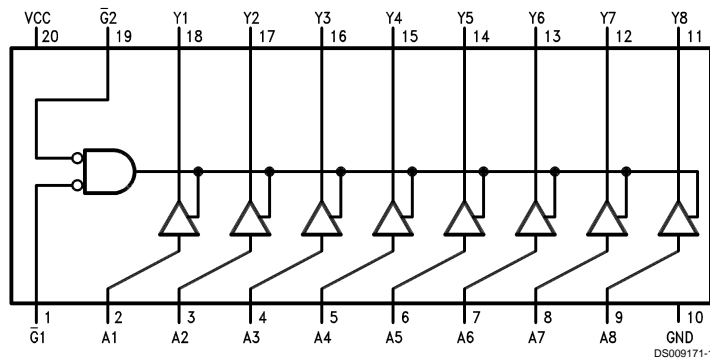

Order Number DM74ALS541WM, DM74ALS541SJ or DM74ALS541N
See Package Number M20B, M20D or N20A

Function Table

Input			Output
$\bar{G}1$	$\bar{G}2$	A	Y
H	X	X	Hi-Z
X	H	X	Hi-Z
L	L	L	L
L	L	H	H

H = High Logic Level, L = Low Logic Level
X = Don't Care (Either Low or High Logic Level)
Hi-Z = High Impedance (Off) State

Absolute Maximum Ratings (Note 1)

Supply Voltage	7V	Range	DM74ALS	0°C to +70°C
Input Voltage: Control Inputs	7V	Storage Temperature Range		-65°C to +150°C
Voltage Applied to a Disabled 3-STATE Output	5.5V	Typical θ_{JA}	N Package	58.5°C/W
Operating Free-Air Temperature			M Package	77.5°C/W

Recommended Operating Conditions

Symbol	Parameter	DM74ALS541			Units
		Min	Nom	Max	
V_{CC}	Supply Voltage	4.5	5	5.5	V
V_{IH}	High Level Input Voltage	2			V
V_{IL}	Low Level Input Voltage			0.8	V
I_{OH}	High Level Output Current			-15	mA
I_{OL}	Low Level Output Current			24	mA
T_A	Free Air Operating Temperature	0		70	°C

Note 1: The "Absolute Maximum Ratings" are those values beyond which the safety of the device cannot be guaranteed. The device should not be operated at these limits. The parametric values defined in the "Electrical Characteristics" table are not guaranteed at the absolute maximum ratings. The "Recommended Operating Conditions" table will define the conditions for actual device operation.

Electrical Characteristics

over recommended free air temperature range

Symbol	Parameter	Test Conditions	Min	Typ	Max	Units	
V_{IK}	Input Clamp Voltage	$V_{CC} = \text{Min}, I_I = -18 \text{ mA}$			-1.2	V	
V_{OH}	High Level Output Voltage	$V_{CC} = 4.5\text{V to } 5.5\text{V}$	$I_{OH} = -0.4 \text{ mA}$	$V_{CC} - 2$		V	
		$V_{CC} = \text{Min}$	$I_{OH} = -3 \text{ mA}$	2.4	3.2		
			$I_{OH} = \text{Max}$	2			
V_{OL}	Low Level Output Voltage	$V_{CC} = \text{Min}$	$I_{OL} = 12 \text{ mA}$		0.25	0.4	mA
			$I_{OL} = 24 \text{ mA}$		0.35	0.5	
I_I	Input Current at Max Input Voltage	$V_{CC} = \text{Max}, V_I = 7\text{V}$			100	μA	
I_{IH}	High Level Input Current	$V_{CC} = \text{Max}, V_I = 2.7\text{V}$			20	μA	
I_{IL}	Low Level Input Current	$V_{CC} = \text{Max}, V_I = 0.4\text{V}$			-100	μA	
I_{OZH}	High Level 3-STATE Output Current	$V_{CC} = \text{Max}, V_O = 2.7\text{V}$			20	μA	
I_{OZL}	Low Level 3-STATE Output Current	$V_{CC} = \text{Max}, V_O = 0.4\text{V}$			-20	μA	
I_O	Output Drive Current	$V_{CC} = \text{Max}, V_O = 2.25\text{V}$	-30		-112	mA	
I_{CC}	Supply Current	$V_{CC} = \text{Max}$	Outputs High	6	14	mA	
			Outputs Low		15		25
			Outputs Disabled		13.5		22

Switching Characteristics

over recommended operating free air temperature range (Note 2)

Symbol	Parameter	Conditions	From (Input) To (Output)	DM74ALS541		Units
				Min	Max	
t _{PLH}	Propagation Delay Time Low to High Level Output	V _{CC} = 4.5V to 5.5V, R ₁ = R ₂ = 500Ω, C _L = 50 pF	A to Y	4	14	ns
t _{PHL}	Propagation Delay Time High to Low Level Output		A to Y	2	10	ns
t _{PZH}	Output Enable Time to High Level Output		\bar{G} to Y	5	15	ns
t _{PZL}	Output Enable Time to Low Level Output		\bar{G} to Y	8	20	ns
t _{PHZ}	Output Disable Time from High Level Output		\bar{G} to Y	1	10	ns
t _{PLZ}	Output DisableTime from Low Level Output		\bar{G} to Y	2	12	ns

Note 2: See Section 1 for test waveforms and output load.

Physical Dimensions inches (millimeters) unless otherwise noted

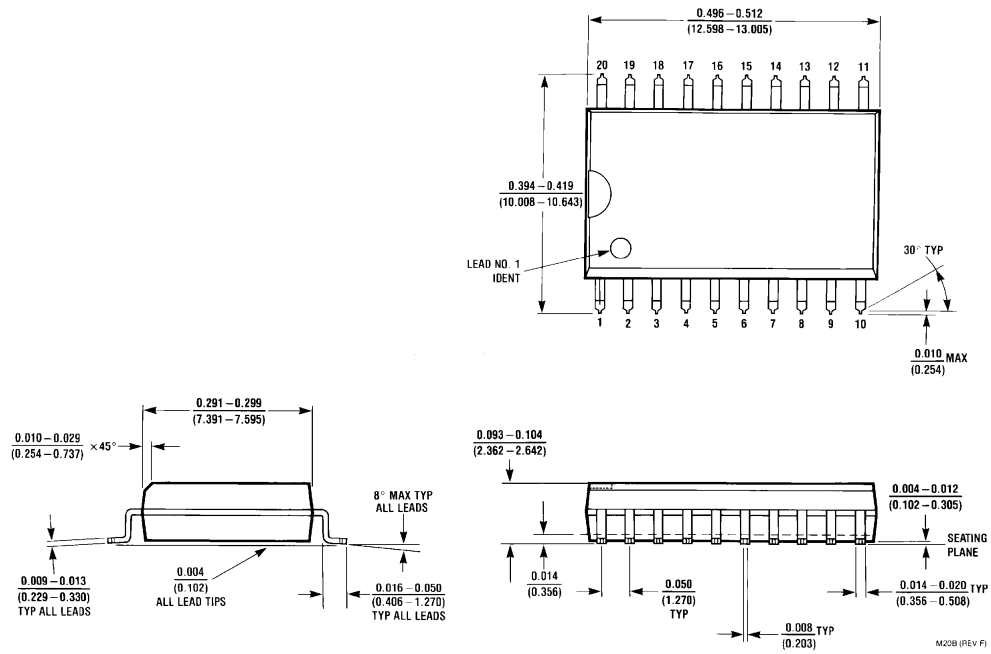

S.O. Package (M)
Order Number DM74ALS541WM
Package Number M20B

M20B (REV F)

LIFE SUPPORT POLICY

FAIRCHILD'S PRODUCTS ARE NOT AUTHORIZED FOR USE AS CRITICAL COMPONENTS IN LIFE SUPPORT DEVICES OR SYSTEMS WITHOUT THE EXPRESS WRITTEN APPROVAL OF THE PRESIDENT OF FAIRCHILD SEMICONDUCTOR CORPORATION. As used herein:

1. Life support devices or systems are devices or systems which, (a) are intended for surgical implant into the body, or (b) support or sustain life, and (c) whose failure to perform when properly used in accordance with instructions for use provided in the labeling, can be reasonably expected to result in a significant injury to the user.
2. A critical component in any component of a life support device or system whose failure to perform can be reasonably expected to cause the failure of the life support device or system, or to affect its safety or effectiveness.

Fairchild Semiconductor Corporation Americas
Customer Response Center
Tel: 1-888-522-5372

Fairchild Semiconductor Europe
Fax: +49 (0) 1 80-530 85 86
Email: europe.support@nsc.com
Deutsch Tel: +49 (0) 8 141-35-0
English Tel: +44 (0) 1 793-85-68-56
Italy Tel: +39 (0) 2 57 5631

Fairchild Semiconductor Hong Kong Ltd.
13th Floor, Straight Block,
Ocean Centre, 5 Canton Rd.
Tsimshatsui, Kowloon
Hong Kong
Tel: +852 2737-7200
Fax: +852 2314-0061

National Semiconductor Japan Ltd.
Tel: 81-3-5620-6175
Fax: 81-3-5620-6179

www.fairchildsemi.com