

DM74ALS580A Octal D-Type Transparent Latch with 3-STATE Outputs

General Description

These 8-bit registers feature totem-pole 3-STATE outputs designed specifically for driving highly-capacitive or relatively low-impedance loads. The high-impedance state and increased high-logic-level drive provide these registers with the capability of being connected directly to and driving the bus lines in a bus-organized system without need for interface or pull-up components. They are particularly attractive for implementing buffer registers, I/O ports, bidirectional bus drivers, and working registers.

The eight inverting latches of the ALS580A are transparent D-type latches. While the enable (G) is high the Q outputs will follow the complement of the data (D) inputs. When the enable is taken low the output will be latched at the complement of the level of the data that was set up.

A buffered output control input can be used to place the eight outputs in either a normal logic state (high or low logic levels) or a high-impedance state. In the high-impedance state the outputs neither load nor drive the bus lines significantly.

The output control does not affect the internal operation of the latches. That is, the old data can be retained or new data can be entered even while the outputs are off.

Features

- Switching specifications at 50 pF
- Switching specifications guaranteed over full temperature and V_{CC} range
- Advanced oxide-isolated, ion-implanted Schottky TTL process
- 3-STATE buffer-type outputs drive bus lines directly

Connection Diagram

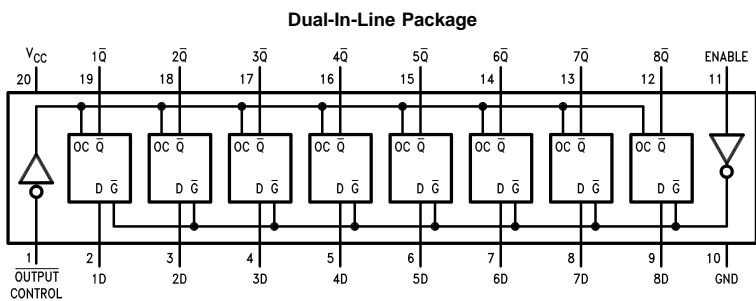

Order Number DM74ALS580AWM or DM74ALS580AN
See Package Number M20B or N20A

Function Table

Output Control	Enable G	D	Output \bar{Q}
L	H	H	L
L	H	L	H
L	L	X	\bar{Q}_0
H	X	X	Z

L = Low State, H = High State, X = Don't Care
Z = High Impedance State
 \bar{Q}_0 = Previous Condition of \bar{Q}

DM74ALS580A Octal D-Type Transparent Latch with 3-STATE Outputs

Absolute Maximum Ratings (Note 2)

Supply Voltage	7V	DM74ALS	0°C to +70°C
Input Voltage	7V	Storage Temperature Range	-65°C to +150°C
Voltage Applied to Disabled Output	5.5V	Typical θ_{JA}	
Operating Free Air Temperature Range		N Package	56.0°C/W
		M Package	75.0°C/W

Recommended Operating Conditions

Symbol	Parameter	DM74ALS580A			Units
		Min	Nom	Max	
V_{CC}	Supply Voltage	4.5	5	5.5	V
V_{IH}	High Level Input Voltage	2			V
V_{IL}	Low Level Input Voltage			0.8	V
I_{OH}	High Level Output Current			-2.6	mA
I_{OL}	Low Level Output Current			24	mA
t_W	Width of Enable Pulse, High or Low	15			ns
t_{SU}	Data Setup Time (Note 3)	10↓			ns
t_H	Data Hold Time (Note 3)	10↓			ns
T_A	Free Air Operating Temperature	0		70	°C

Note 1: This product meets application requirements of 500 temperature cycles from -65°C to +150°C.

Note 2: The "Absolute Maximum Ratings" are those values beyond which the safety of the device cannot be guaranteed. The device should not be operated at these limits. The parametric values defined in the "Electrical Characteristics" table are not guaranteed at the absolute maximum ratings. The "Recommended Operating Conditions" table will define the conditions for actual device operation.

Note 3: The (↓) arrow indicates the negative edge of the enable is used for reference.

Electrical Characteristics

over recommended operating free air temperature range. All typical values are measured at $V_{CC} = 5V$, $T_A = 25^\circ C$.

Symbol	Parameter	Conditions	Min	Typ	Max	Units	
V_{IK}	Input Clamp Voltage	$V_{CC} = 4.5V$, $I_I = -18 mA$			-1.2	V	
V_{OH}	High Level Output Voltage	$V_{CC} = 4.5V$ $V_{IL} = V_{ILMax}$	$I_{OH} = Max$	2.4	3.2	V	
		$V_{CC} = 4.5V$ to 5.5V	$I_{OH} = -400 \mu A$	$V_{CC} - 2$		V	
V_{OL}	Low Level Output Voltage	$V_{CC} = 4.5V$ $V_{IH} = 2V$	$I_{OL} = 12 mA$		0.25	0.4	V
			$I_{OL} = 24 mA$		0.35	0.5	V
I_I	Input Current @ Max Input Voltage	$V_{CC} = 5.5V$, $V_{IH} = 7V$			0.1	mA	
I_{IH}	High Level Input Current	$V_{CC} = 5.5V$, $V_{IH} = 2.7V$			20	μA	
I_{IL}	Low Level Input Current	$V_{CC} = 5.5V$, $V_{IL} = 0.4V$			-0.1	mA	
I_O	Output Drive Current	$V_{CC} = 5.5V$, $V_O = 2.25V$	-30		-112	mA	
I_{OZH}	Off-State Output Current High Level Voltage Applied	$V_{CC} = 5.5V$, $V_{IH} = 2V$ $V_O = 2.7V$			20	μA	
I_{OZL}	Off-State Output Current Low Level Voltage Applied	$V_{CC} = 5.5V$, $V_{IH} = 2V$ $V_O = 0.4V$			-20	μA	
I_{CC}	Supply Current	$V_{CC} = 5.5V$ Outputs Open	Output High		10	17	mA
			Output Low		16	26	mA
			Outputs Disabled		17	29	mA

Switching Characteristics

over recommended operating free air temperature range (Note 4)

Symbol	Parameter	Conditions	From	To	DM74ALS580A		Units
					Min	Max	
t _{PLH}	Propagation Delay Time Low to High Level Output	V _{CC} = 4.5V to 5.5V R _L = 500Ω C _L = 50 pF	Data	Any \bar{Q}	3	18	ns
t _{PHL}	Propagation Delay Time High to Low Level Output		Data	Any \bar{Q}	3	14	ns
t _{PLH}	Propagation Delay Time Low to High Level Output		Enable	Any \bar{Q}	8	22	ns
t _{PHL}	Propagation Delay Time High to Low Level Output		Enable	Any \bar{Q}	8	21	ns
t _{PZH}	Output Enable Time to High Level Output		Output Control	Any \bar{Q}	4	18	ns
t _{PZL}	Output Enable Time to Low Level Output		Output Control	Any \bar{Q}	4	18	ns
t _{PHZ}	Output Disable Time from High Level Output		Output Control	Any \bar{Q}	2	10	ns
t _{PLZ}	Output Disable Time from Low Level Output		Output Control	Any \bar{Q}	3	15	ns

Note 4: See Section 5 for test waveforms and output load.

Logic Diagram

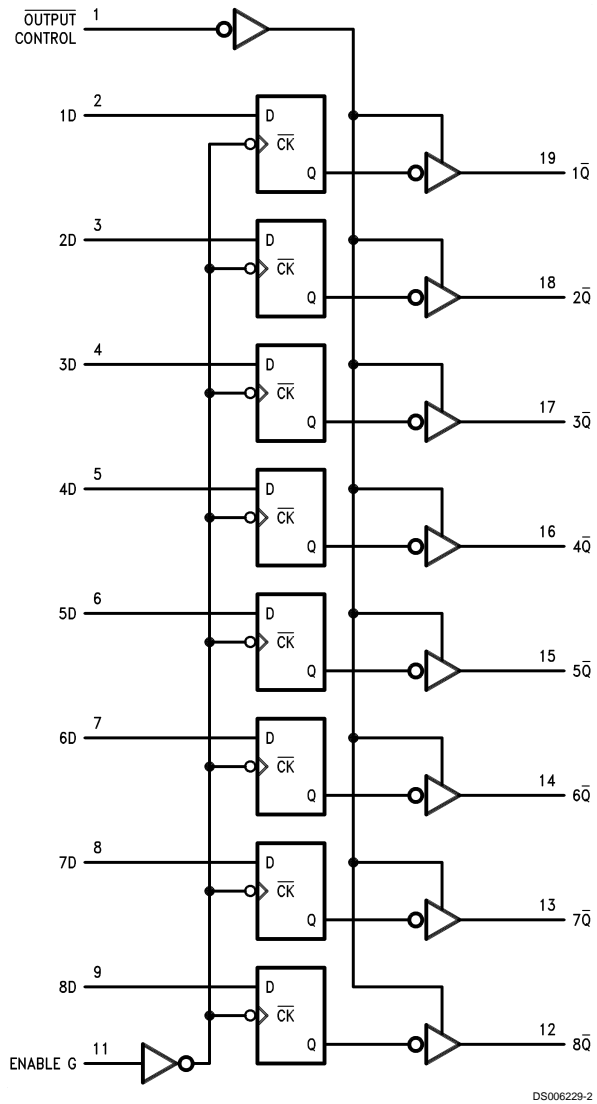

LIFE SUPPORT POLICY

FAIRCHILD'S PRODUCTS ARE NOT AUTHORIZED FOR USE AS CRITICAL COMPONENTS IN LIFE SUPPORT DEVICES OR SYSTEMS WITHOUT THE EXPRESS WRITTEN APPROVAL OF THE PRESIDENT OF FAIRCHILD SEMICONDUCTOR CORPORATION. As used herein:

1. Life support devices or systems are devices or systems which, (a) are intended for surgical implant into the body, or (b) support or sustain life, and (c) whose failure to perform when properly used in accordance with instructions for use provided in the labeling, can be reasonably expected to result in a significant injury to the user.
2. A critical component in any component of a life support device or system whose failure to perform can be reasonably expected to cause the failure of the life support device or system, or to affect its safety or effectiveness.

Fairchild Semiconductor Corporation Americas
Customer Response Center
Tel: 1-888-522-5372

Fairchild Semiconductor Europe
Fax: +49 (0) 1 80-530 85 86
Email: europe.support@nsc.com
Deutsch Tel: +49 (0) 8 141-35-0
English Tel: +44 (0) 1 793-85-68-56
Italy Tel: +39 (0) 2 57 5631

Fairchild Semiconductor Hong Kong Ltd.
13th Floor, Straight Block,
Ocean Centre, 5 Canton Rd.
Tsimshatsui, Kowloon
Hong Kong
Tel: +852 2737-7200
Fax: +852 2314-0061

National Semiconductor Japan Ltd.
Tel: 81-3-5620-6175
Fax: 81-3-5620-6179

www.fairchildsemi.com